

K. BROOKS.

FOLDING BED.

No. 359,768.

Patented Mar. 22, 1887.

Fig. 1.

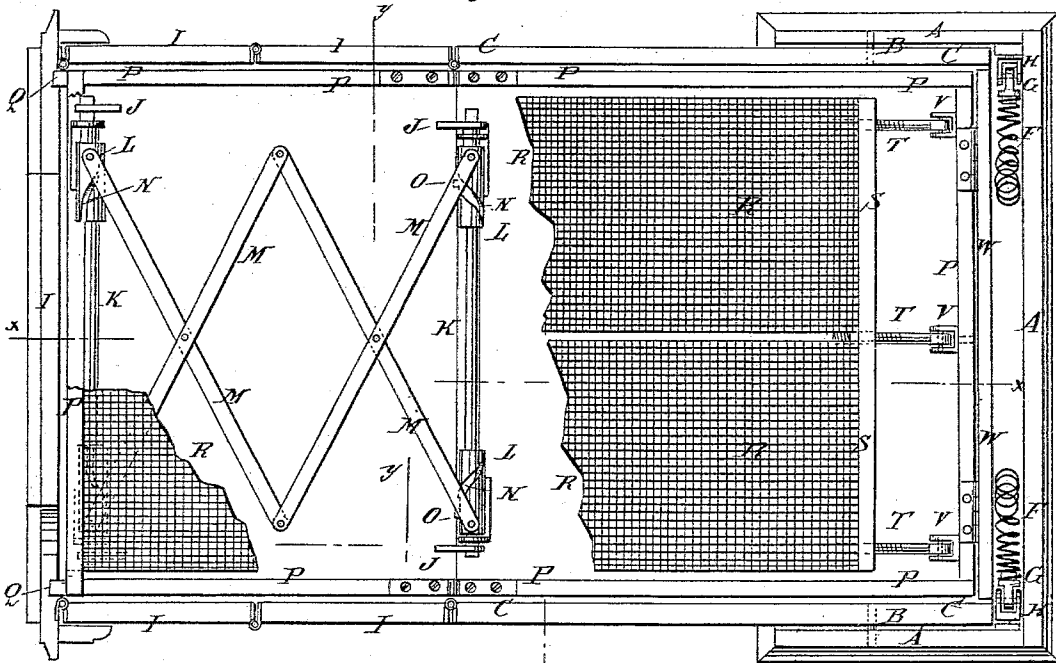

Fig. 3.

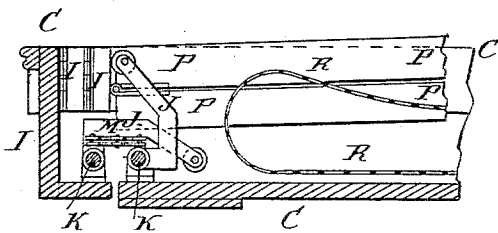
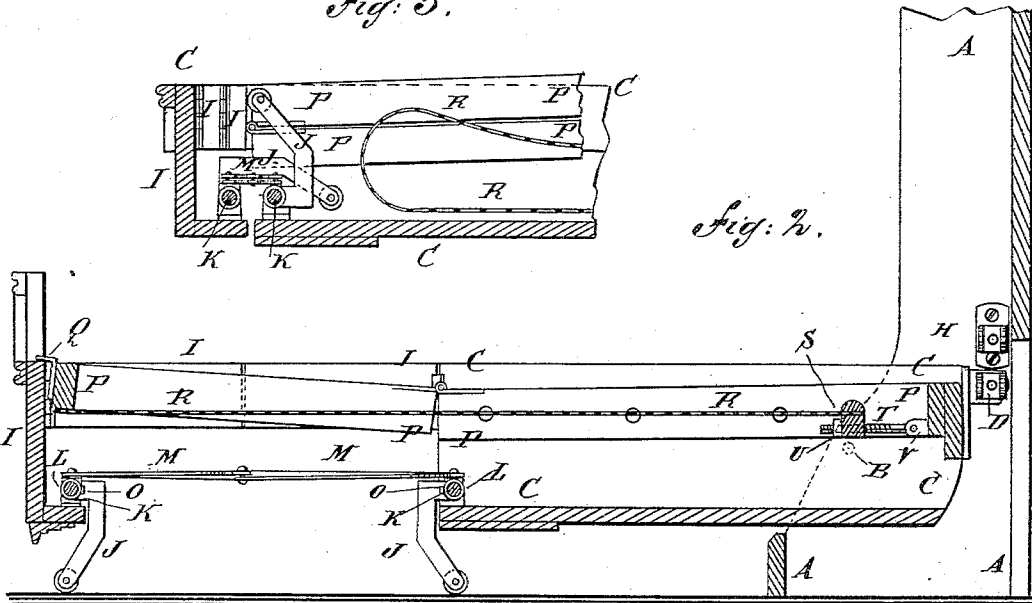

Fig. 2.



WITNESSES:

Alnas Nida
C. Sedgwick

INVENTOR:

K. Brooks
 BY *Munn & Co.*
 ATTORNEYS.

K. BROOKS.
FOLDING BED.

No. 359,768.

Patented Mar. 22, 1887.

Fig. 4.

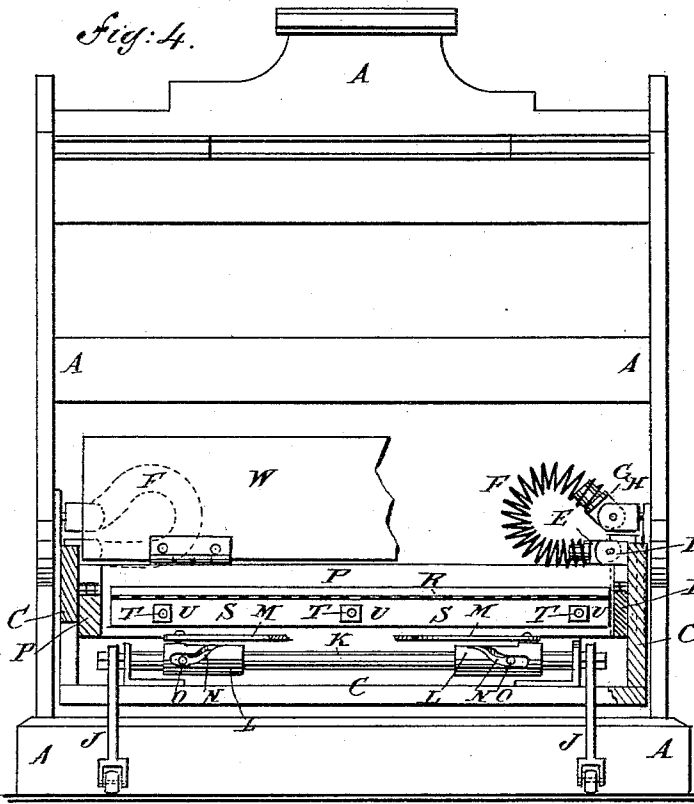

Fig. 5.

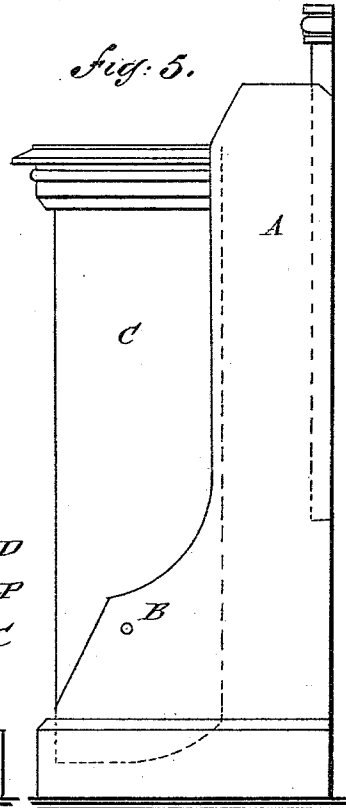
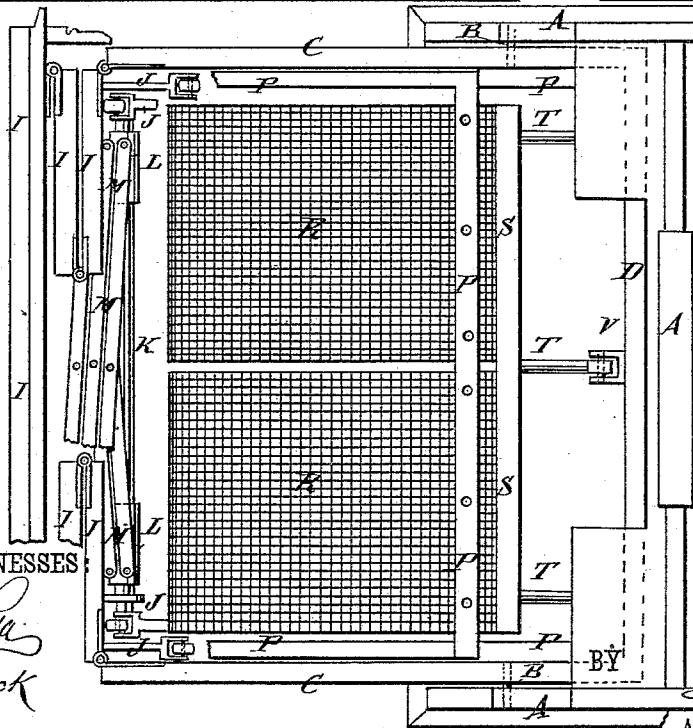

Fig. 6.



WITNESSES:

Chas. Chas.
Co. Bedgwick

INVENTOR:

K. Brooks
Munn & Co.

ATTORNEYS.

UNITED STATES PATENT OFFICE.

KARMELL BROOKS, OF NEW YORK, N. Y.

FOLDING BED.

SPECIFICATION forming part of Letters Patent No. 359,768, dated March 22, 1887.

Application filed March 3, 1886. Serial No. 193,869. (No model.)

To all whom it may concern.

Be it known that I, KARMELL BROOKS, of the city, county, and State of New York, have invented a new and useful Improvement in Folding Beds, of which the following is a full, clear, and exact description.

Reference is to be had to the accompanying drawings, forming a part of this specification, in which similar letters of reference indicate corresponding parts in all the figures.

Figure 1 is a plan view of my improved folding bed opened, part being broken away. Fig. 2 is a sectional side elevation of the same, taken through the line *xx*, Fig. 1. Fig. 3 is a sectional side elevation of a part of the same, partly closed. Fig. 4 is a sectional front elevation of the folding bed opened, taken through the broken line *yyy*, Fig. 1, part being broken away. Fig. 5 is a side elevation of the same closed. Fig. 6 is a plan view of the same, partly closed, parts being broken away.

The object of this invention is to provide folding beds constructed in such a manner that they can be conveniently opened and closed, and will be reliable and durable in use.

The invention consists in the construction and combination of various parts of the folding bed, as will be hereinafter fully described.

A represents the stationary part of the folding bed. To the lower forward parts of the sides of the stationary part A, and at a suitable distance above its base, are attached pivots B, to which are pivoted the side boards of the head-section C of the movable part of the bed.

To the end of the section C, near its corners, or to base-plates attached to the said end, are swiveled brackets D, to which are hinged heads E, attached to the lower ends of spiral springs F. The spiral springs F are bent into U shape, and their other ends are attached to heads G, which are hinged to brackets H, attached or swiveled to the stationary part of the bed, or to base-plates attached to the said part in such positions as to be over or nearly over the brackets D.

The springs F are designed to be made of such a strength as to nearly balance the folding part of the bed, so that the said folding part can be readily opened and closed. The

foot section I of the movable part of the bed is made with its side bars in two parts, which are hinged to each other at their adjacent ends. The other ends of the forward parts of the bars are hinged to the ends of the side bars of the head-section C, and the other ends of the rear parts of the bars are hinged to the ends of the foot-board of the said foot-section I.

The hinges of the side bars of the foot-section I are so arranged, as shown in Fig. 1, that the said side bars will fold inward, as shown in Fig. 6, bringing the foot-board of the foot-section I near the ends of the side bars of the head-section C, and thus shortening the folding part of the bed.

The folding part of the bed, when lowered into a horizontal position and extended, is supported by four legs, J, attached to the ends of rods K, which rock in bearings attached to the end of the head-section C and to the cross-bar of the foot-board of the foot-section I. Upon the end parts of the rock-rods K are placed sleeves L, to which are pivoted the ends of a lazy-tongs, M, so that the said sleeves will be moved outward and inward upon the said rods K as the said lazy-tongs are closed and opened. In the sleeves L are formed grooves N, into which project pins O, attached to the rock-rods K. The grooves N of the rear sleeves, L, are so curved that the outward movement of the said sleeves when the lazy-tongs M are closed will turn the rear rod, K, through so much of a revolution as will raise the rear legs, J, a little above a horizontal position, so that they will pass forward above the bottom of the head-section when the foot-section I is closed.

The grooves N of the forward sleeves, L, are so curved that the outward movement of the said sleeves when the lazy-tongs M are closed will turn the forward rod, K, through so much of a revolution as will raise the forward legs, J, so high that they will not interfere with the closing of the foot-section I, as shown in Fig. 3.

P is the bed-bottom frame, the side bars of which are made in two parts, hinged to each other at the upper corners of their adjacent ends, so that the foot part of the said frame can be folded over the head part. The head part of the frame P is rigidly secured to the

head-section C of the folding part of the bed, and to the end bar of the foot part of the said frame P are attached hooks Q, or other suitable stops, which engage with the upper edge of the foot-board of the foot-section I when the frame P is opened to assist in supporting the foot part of the said frame, and thus relieve the hinges of the said frame from an undue strain.

To the lower edge of the end bar of the foot part of the frame P is attached the foot end of the bed-bottom R, which is made in two parts, as shown in Figs. 1 and 6, to prevent it from sagging in the middle when the bed is used by two people, and causing them to roll toward each other. The head end of the bed-bottom R is secured to the upper edge of the cross-bar S, which is perforated to receive three or more screws, T. The screws T have nuts U screwed upon them at the forward side of the cross-bar S, and their heads are hinged to lugs V, attached to the head end bar of the frame P, so that the head end of the bed-bottom R can swing downward when the frame P is folded to provide space for the mattress and bedding.

With this construction, when the bed is to be opened, the movable part is swung down into a horizontal position. The foot-section I is then extended, which causes the lazy-tongs M to swing the legs I downward into position to support the said movable part of the bed. The frame P is then unfolded and the bed is ready for use. When the bed is to be closed, the frame P is folded and the foot-section I is closed, which causes the lazy-tongs M to swing the legs J up out of the way, and the movable part of the bed is turned up into the stationary part.

The bedding is kept from contact with the springs F by a board, W, which is hinged at its lower edge to the end bar of the frame P, as shown in Figs. 1 and 4, so that it will not impede the folding of the bed.

I am aware that in a folding bed a spiral

spring having one end secured to the folding part of the bed and its other end hinged to an arm sliding in a slotted bracket on the stationary part of the bed is old, and I am also aware that the side rails of a bed have been made in three sections hinged together, so that the end sections may fold over upon the main or central section, and I therefore do not claim such inventions.

Having thus fully described my invention, I claim as new and desire to secure by Letters Patent—

1. In a folding bed, the combination, with the stationary part A and the movable head-section C, of the brackets D H, swiveled to the parts A and C, respectively, the heads E G, hinged to the said brackets, and the springs F, secured to the said heads and arranged transversely with the bed, substantially as herein shown and described.

2. In a folding bed, the combination, with the hinged head-section C of the movable part of the bed, of the foot-section I, composed of side bars and foot-board, each of its side bars made in two parts hinged together, and having their ends hinged to the head-section and foot-board, substantially as herein shown and described, for the purpose set forth.

3. In a folding bed, the combination, with the head-section C of the movable part of the bed, and the extensible foot-section I, of the rock-rods K, having guide-pins O, the sleeves L, sliding upon the said rock-rods and having curved grooves N to receive the said guide-pins, the lazy-tongs M, pivoted to the said sleeves, and the legs J, attached to the said rock-rods, substantially as herein shown and described, whereby the said legs will be swung down when the said foot-section is extended and swung up out of the way when the said foot-section is closed, as set forth.

KARMELL BROOKS.

Witnesses:

JAMES T. GRAHAM,
C. SEDGWICK.