

⑫ **EUROPEAN PATENT SPECIFICATION**

- ⑬ Date of publication of patent specification: **02.12.87** ⑭ Int. Cl.⁴: **B 65 D 71/00**
⑮ Application number: **84200548.0**
⑯ Date of filing: **18.04.84**

⑰ **Combined lock structure for article carrier.**

- | | |
|--|--|
| <p>⑱ Priority: 26.04.83 US 488673</p> <p>⑲ Date of publication of application:
31.10.84 Bulletin 84/44</p> <p>⑳ Publication of the grant of the patent:
02.12.87 Bulletin 87/49</p> <p>㉑ Designated Contracting States:
DE FR GB IT</p> <p>㉒ References cited:
US-A-2 990 997
US-A-3 223 308
US-A-3 374 938
US-A-4 164 286
US-A-4 200 220</p> | <p>㉓ Proprietor: CERTIPAK CORPORATION
10 Greenwich Plaza P.O. Box 621
Greenwich, Connecticut 06830 (US)</p> <p>㉔ Inventor: Collura, Peter Charles
Box 105620
Atlanta Georgia 30348 (US)
Inventor: Humphries, Richard Lyle
Box 105620
Atlanta Georgia 30348 (US)
Inventor: Lever, John Keith
Box 105620
Atlanta Georgia 30348 (US)</p> <p>㉕ Representative: Hulse, Thomas Arnold et al
Hulse & Co. Cavendish Buildings West Street
Sheffield S1 1ZZ (GB)</p> |
|--|--|

Note: Within nine months from the publication of the mention of the grant of the European patent, any person may give notice to the European Patent Office of opposition to the European patent granted. Notice of opposition shall be filed in a written reasoned statement. It shall not be deemed to have been filed until the opposition fee has been paid. (Art. 99(1) European patent convention).

EP 0 123 358 B1

Description

Technical Field

This invention relates to an article carrier of the wraparound type and, more particularly, to a carrier for packaging a plurality of articles in at least one row having an improved thread-and-punch type lock for interlocking overlapping panels of the carrier.

Background Art

U.S. Patent 4 200 220 to Ganz is directed to an article carrier of the wraparound type in which the bottom panels of an elongated blank are secured in overlapping relation. Tongues on one of the bottom panels are threaded into corresponding transversely elongated slits in the other of the bottom panels, but this is done only after doubling over each bottom panel with a fold of 180°. Each of the tongues has a tab longitudinally aligned therewith for disposition in a cooperating elongated slit on the opposite bottom panel. However, when locked in place, there is no edge-to-edge engagement for the best locking performance. Instead the tab lies in a plane substantially perpendicular to the plane in which the tongue lies.

This carton requires complicated machinery to perform the doubling over folds and threading of the tongue and tab. Also, the tab which extends vertically into the interior of the carton is susceptible to damage by the articles within the carrier and, in a damaged state, likely to slip back through the receiving slit. The doubling feature greatly increases the cost of the carrier due to the increase in paperboard required.

U.S. Patents 2 990 997 and 3 223 308 to Weiss are both also directed to an article carrier of the wraparound type of sheet material for packaging of a plurality articles in at least one row including:

(a) an elongated blank having fold lines to form a top panel, two side panels and first and second bottom, closure panels designed to overlap when applied to the articles to be packaged;

(b) said first closure panel including a plurality of locking units, each locking unit having a tongue along the transverse, terminal edge of said first closure panel and a locking tab in longitudinal alignment therewith;

(c) said second closure panel including a plurality of first and second transversely elongated openings, said first openings being adjacent and substantially parallel to said second openings and lying parallel to and between said second openings and the transverse, terminal edge of said second closure panel, said transverse, terminal edge of said second closure panel being opposite to said transverse, terminal edge of said first closure panel on said blank,

and wherein said second closure panel includes closure panel material between said first and second openings, said material forming a protector strap, one protector strap being in longitudinal alignment with each locking unit; each of said second openings having one of said tongues

threadable therein so that said tongue overlies said second closure panel when said first and second closure panels are in overlapping relation, each of said first openings having one of said locking tabs punchable therein so that said tab overlies said second closure panel and provides edge-to-edge engagement with said first opening.

During the retail life of these carriers, many are subject to rough handling and other conditions having a tendency to loosen or release the locks. Also, the carriers are routinely exposed to refrigerated conditions. Under such conditions the paper with which the carrier is formed may absorb moisture and consequently lose stiffness. This causes the locks to be more susceptible to inadvertent lock release. Because of this, improved locking strength and lock protection is a vital concern continually sought by those skilled in the packaging art.

Therefore, in U.S. Patent 2 990 997 said first and second openings are elongated slits such that the protector strap extends the full width between both slits and overlies the locking tab along the interior of said article carrier to retain said locking tab in edge-to-edge engagement and provide extra strength.

As will be seen below, the carrier of the present invention is an improvement over the prior art disclosed in U.S. Patent 2,990,997 in that it insures the required relief for ease of engaging the lock units by providing relief slits extending at different angles from said first and second slits.

Disclosure of the Invention

Accordingly, it is a primary object of the present invention to provide a wraparound carrier which overcomes the limitations and disadvantages of the prior art as described.

More specifically, it is an object of the present invention to provide a wraparound carrier with improved locking retention and additional strength and durability.

Another object of the invention is to provide a wraparound carrier which minimizes paperboard requirement and thus costs less to manufacture.

Another object of this invention is to provide a lock structure in a wraparound carrier including spaced locking slits to receive and retain a locking unit with protection against inadvertent release.

Still another object of this invention is to provide a lock in a carrier having specially formed slits for the purpose indicated to provide improved lock performance and additional security.

Still another object of this invention is to provide a wraparound carrier with an improved lock as described that is easy to erect on existing high-speed equipment.

Additional objects, advantages, and other novel features of the invention will be set forth in part in the description that follows and in part will become apparent to those skilled in the art upon examination of the following or may be learned with practice of the invention. The objects and advantages of the invention may be realized and

attained by means of the instrumentalities and combinations particularly pointed out in the appended claims.

To achieve the foregoing and other objects, and in accordance with the purposes of the present invention as described herein, an article carrier of the wraparound type disclosed in US—A—2 990 997 is characterised by the features specified in the characterising portion of claim 1.

The tongue and locking tab extending in opposing directions and engaging the locating edge and the locking edge of the two slits, respectively, are within the same plane and thus provide the carrier with secure edge-to-edge engagement between the closure panels. Since the tab does not extend vertically up into the carrier but instead is positively held down by the protector strap, it is protected from being inadvertently damaged and dislodged by articles therein. Also, the positive edge-to-edge engagement prevents either the threaded tongue or the punched-in-tab from slipping through its slit. Improved locking retention that in turn improves carton reliability is the favorable result obtained.

Since the invention employs two, substantially parallel, transversely elongated slits, and a protector strap in between, the need to strip the trim from a hole or aperture, as often required in the prior art is avoided. This feature, coupled with reduced paperboard required with respect to some designs, substantially reduces the cost incurred by the manufacturer.

Advantageously, the present invention provides convenient mechanical threading and punching for easy adaptation to high speed, state of the art automation techniques and machines.

Still further, the protector strap which overlies the tab along the interior of the carrier to hold the tab in locked engagement also increases the strength of the panel in the lock area, whereas before, a relatively wide aperture (absence of material) existed, the protector strap connected by bridges at each end spans the lock area. This strap provides an article carrier of increased strength over those in the prior art even after exposure to refrigerated conditions wherein the paper absorbs moisture and loses stiffness.

Still other objects of the present invention will become readily apparent to those skilled in the art in the following description wherein there is shown and described a preferred embodiment of this invention, simply by way of illustration of one of the modes best suited to carry out the invention. Accordingly, the drawings and description will be regarded as illustrative in nature and not as restrictive.

Brief Description of the Drawings

The accompanying drawings incorporated in and forming a part of the specification, illustrate several aspects of the present invention, and together with the description serve to explain the principles of the invention. In the drawings:

Figure 1 is a top plan view of an elongated blank from which an article carrier of the present invention is formed;

Figure 2 is a perspective view of the article carrier of the present invention having a plurality of articles such as bottles, supported therein after completion of forming the blank into the carrier;

Figure 3 is a fragmentary inside perspective view of the carrier showing the relation of the bottom panels of the blank when in proper overlapping and locked relation;

Figure 4A is an enlarged fragmentary plan view showing in more detail the threading of the tongue through the transversely elongated slit furthest from the edge of the opposite closure panel;

Figure 4B is a similar fragmentary plan view showing the relationship of the closure panels following the punching of the locking tab in the slit nearest the edge of the opposite closure panel; and

Figure 4C is an underside fragmentary plan view showing the relationship of the locking tab and the tongue within the transversely elongated slits of the blank.

Detailed Description of the Invention

Referring to the drawings and particularly to Figure 2, there is shown an article carrier 10 of the wraparound type for a plurality of articles such as bottles 11, for example, arranged in one or more rows. As shown in Figure 2, the bottles 11 are arranged in two rows, but there can be only a single row or more than two rows.

The article carrier 10 is formed from an elongated blank 12 (see Figure 1) of a suitable foldable sheet material such as paperboard, for example. The elongated blank 12 has a single top panel 14 with circular apertures 13 cut therein to accommodate the necks of the bottles 11.

Side panels 16 are articulated or hingedly joined to opposite sides of the top panel 14 along a pair of top fold lines 15. The side panels 16 are designed to be substantially vertical in the completed article carrier 10, as shown in Figure 2.

A bottom closure panel 21 is articulated or hingedly joined to one of the side panels 16 along a fold line 22 (see top of Figure 2). Another bottom or closure panel 23 is articulated or hingedly joined to the other of the side panels 16 by fold line 24.

The bottom panel 21 has a plurality of transversely spaced lock units each including a tongue 25 (three shown in Figure 1) with the number of tongues 25 preferably being equal to the number of bottles 11 (see Figure 2) in each of the rows. The tongues 25 (see Figure 1) are spaced from each other by recessed edge portions 26 between the tongues.

The outer ends of the edge along the panel 21 adjacent the end tongues 25 are formed by an edge extension 30 and connect to longitudinal side edges 31 and 32 of the elongated blank 12. The bottom panel 21 thus has its terminal edge

defined by the edges of the tongues 25, the recessed edge portions 26 and the connecting edge extensions 30.

The bottom panel 23 has a plurality of pairs of adjacent, substantially parallel, transversely elongated slits for receiving the corresponding locking units when the closure panels are in proper overlapping relation.

First transversely elongated slits 33 are formed adjacent the terminal edge 34 of the bottom panel 23, between the terminal edge 34 and second transversely elongated slits 35.

The bottom panel material disposed between the first slits 33 and second slits 35 forms a protector strap 38. The first slit 33 includes relief extensions 33a at each end thereof, and these extensions 33a extend toward said adjacent second slit 35 at an angle of substantially 135° from the slit 33. The second slit 35 includes relief slits 35a at each end thereof, and these relief slits 35a extend toward said adjacent first slit 33 at an angle of substantially 90° from said second slit 35; the corner is rounded to minimize the tendency to tear the paperboard.

The relief extensions 33a and relief slits 35a further define the bridges at the ends of the protector strap 38. The bridges (see Figures 1 and 4) have a length substantially equal to the combined length of relief extensions 33a and slits 35a to insure maximum strength while at the same time providing the required relief for ease of engaging the lock units.

Each of the tongues 25 is threadable into one of the transversely elongated slits 35 when the bottom or closure 21 and 23 are in overlapping relation. Each tongue 25 overlies the inner transverse edge of the corresponding slit 35 so as to have a relatively large area of overlapping contact (Figure 4A). As can be seen, the edge of the slit 35 forms a locating edge for the locking unit.

The bottom panel 21 has a set of locking tabs, designated by the reference numeral 39; a single locking tab being longitudinally aligned with each of the tongues 25. The locking tabs 39 are formed through slitting the bottom panel 21 and may be bifurcated, as shown in the preferred embodiment. The locking tabs 39 and the tongues 25 together form the locking unit, generally designated by the reference numeral 40 (Figures 1 and 3).

When the elongated blank 12 is folded to form the carrier 10 with the bottles 11 therein, the bottom panels 21 and 23 are in overlapping relation (see Figures 2 and 3). When each tongue 25 is first threaded within the corresponding transversely elongated slit 35, the locking tab 39 underlies the closure panel 23 (see Figure 4A looking from inside).

The locking tab 39 is then punched (from below) through the transversely elongated slit 33 so that the locking tab 39 directly overlies closure panel 23 thereby providing edge to edge engagement with the transverse edge (see Figure 4B). Further, the protector strap 38 overlies the tab 39 to hold the tab in locked engagement while providing

additional strength and support to the carrier 10. A fragmentary view of the fully threaded article carrier 10 from below is shown in Figure 4C.

In forming the carrier 10 from the elongated blank 12, the elongated blank 12 is first placed over the necks of the bottles 11. When the elongated blank 12 is properly seated horizontally on the bottles 11, the side panels 16 are folded down the sides. Then, the bottom panels 21 and 23 are folded under the bottoms of the bottles 11. The tongues 25 are threaded into the transversely elongated slits 35 and the locking tabs 39 are punched into the longitudinally aligned transversely elongated slits 33 by forcing with punching wheels (not shown) past the transverse edge of the slits 33.

The locking arrangement of the present invention enables a relatively large edge to edge locating and locking engagement in a transverse direction. A firm, secure and protected locking engagement safe against inadvertent release is provided. The improved performance is obtained without any increase in paperboard in the blank over that used in the original Pierce carrier shown in the previous Certipak patent cited above, and considerably less than that used in later patents seeking to improve the strength.

The use of slits rather than apertures, as in the prior art, negates the need to strip the trim from the closure panel that receives the locking unit. This not only reduces the manufacturing costs incurred by carton manufacturers, but provides a protective strap 38 overlying the locking tab along the interior of the carrier to hold the tab in locked engagement and provide extra strength. This is a particularly important consideration under refrigerated conditions when the paper absorbs moisture and loses stiffness.

The lock structure of the present invention also provides convenient mechanical threading and punching for adaptation with state of the art machines and improved automation techniques.

The foregoing description of the preferred embodiment of the invention has been presented for purposes of illustration and description. It is not intended to be exhaustive or to limit the invention to the precise form disclosed. Obvious modifications and variations are possible in light of the above teachings. For example, the blank could be provided with slits having different shapes and configurations. The edges of the blank may not necessarily be as shown but could include other shapes and separate angled portions.

Claims

1. An article carrier (10) of the wraparound type of sheet material for packaging a plurality of articles (11) in at least one row including:

(a) an elongated blank (12) having fold lines (15, 22, 24) to form a top panel (14), two sides panels (16) and first and second bottom, closure panels (21, 23) designed to overlap when applied to the articles to be packaged;

(b) said first closure panel (21) including a

plurality of locking units (40), each locking unit (40) having a tongue (25) along the transverse, terminal edge (26) of said first closure panel (21) and a locking tab (39) in longitudinal alignment therewith;

(c) said second closure panel (23) including a plurality of first and second transversely elongated openings (33, 35), said first openings (33) being adjacent and substantially parallel to said second openings (35) and lying parallel to and between said second openings and the transverse terminal edge (34) of said second closure panel (23), said transverse, terminal edge (34) of said second closure panel (23) being opposite to said transverse terminal edge (26, 30) of said first closure panel (21) on said blank,

and wherein said closure panel (23) includes closure panel material between said first and second openings (33, 35), said material forming a protector strap (38), one protector strap (38) being in longitudinal alignment with each locking unit (40); each of said second openings (35) having one of said tongues (25) threadable therein so that said tongue (25) overlies said second closure panel (23) when said first and second closure panels (21, 23) are in overlapping relation, each of said first openings (33) having one of said locking tabs (39) punchable therein so that said tab (39) overlies said second closure panel (23) and provides edge-to-edge engagement with said first opening (33) said first and second openings (33, 35) being elongated slits such that the protector strap (38) extends the full width between both slits (33, 35) and overlies the locking tab (39) along the interior of said article carrier to retain said locking tab (39) in locked edge-to-edge engagement and provide extra strength, said carrier being characterised in that each of said first slits (33) includes a pair of relief extensions (33a), one at each end of said first slit, said extensions (33a) extending toward said adjacent second slit (35) at an angle of substantially 135° from said first slit (33); and each of said second slits (35) includes a pair of relief slits (35a), one relief slit at each end of said second slit (35), said relief slits (35a) extending toward said adjacent first slit (33) at an angle of substantially 90° from said second slit (35); said relief slits (35a) and said relief extensions (33a) terminating with a bridge of closure panel material therebetween, said relief slits (35a) and relief extensions (33a) further outlining said protector straps (38).

2. The article carrier defined in Claim 1, wherein the pair of relief slits (35a) for said second slits (35) are rounded to minimize strain at the 90° corner.

3. The article carrier defined in Claim 1, wherein said bridge at each end of the said first and second slits (33, 33a — 35, 35a) is substantially equal in length to the combination length of the adjacent relief extension (33a) and relief slit (35a) to insure sufficient strength and lock retention.

4. The article carrier defined in Claim 3, wherein said bridge at each end of said first and second slits (33, 33a — 35, 35a) extends along the line of

the relief extension (33a) at substantially 135° toward the end of the relief slit (35a).

Patentansprüche

5

1. Schlingband-Tragepackung (10) aus Karton oder dgl. zum Verpacken einer Anzahl von in wenigstens einer Reihe angeordneten Gegenständen (11), bestehend aus

10

a) einem langgestreckten Bogen (12) mit Knicklinien (15, 22, 24) zur Ausbildung einer Oberplatte (14), zweier Seitenplatten (16) sowie einer ersten und einer zweiten Bodenschließplatte (21, 23), welche derart ausgebildet sind, daß sie beim Anlegen der Packung an die zu verpackenden Gegenstände einander überlappen;

15

b) wobei die erste Schließplatte (21) eine Anzahl von Verschlusseinheiten (40) aufweist, von denen jede Verschlusseinheit (40) eine Zunge (25) längs der querlaufenden Endkante (26) der ersten Schließplatte (21) und eine in Längsrichtung damit fluchtende Sicherungslasche (39) besitzt;

20

c) wobei die zweite Schließplatte (23) eine Anzahl von ersten und zweiten querlaufenden, langgestreckten Öffnungen (33, 35) aufweist, von denen die ersten Öffnungen (33) neden und im wesentlichen parallel zu den zweiten Öffnungen (35) sowie parallel zu und zwischen den zweiten Öffnungen und der querlaufenden Endkante (34) der zweiten Schließplatte (23) liegen, wobei die querlaufende Endkante (34) der zweiten Schließplatte (23) am Boden in die entgegengesetzte Richtung weist wie die querlaufende Endkante (26, 30) der ersten Schließplatte (21),

25

30

35

und wobei in der zweiten Schließplatte (23) zwischen den ersten und den zweiten Öffnungen einen Schutzstreifen (38) bildendes Plattenmaterial vorhanden ist und jeweils ein Schutzstreifen (38) in Längsrichtung mit jeweils einer Verschlusseinheit (40) fluchtet, wobei in jede der zweiten Öffnungen (35) eine der Zungen (25) einführbar ist, sodaß die Zungen (25) auf der zweiten Schließplatte (23) aufliegen, wenn beide Schließplatten (21, 23) einander überlappen, wobei in jede der ersten Öffnungen (33) eine der Sicherungslaschen (39) eindrückbar ist, sodaß diese Sicherungslaschen (39) auf der zweiten Schließplatte (23) aufliegen und einen Kanten-

40

45

50

55

eingriff mit den ersten Öffnungen (33) liefern, wobei die ersten und zweiten Öffnungen (33, 35) als Langschlitze ausgebildet sind, sodaß der Schutzstreifen (38) sich über die volle Breite zwischen beiden Schlitzen (33, 35) erstreckt und an der Innenseite der Tragepackung auf der Sicherungslasche (39) aufliegt, um die Sicherungslasche (39) in blockiertem Kanten-

60

65

5

benachbarten Schlitz (33) in einem Winkel von im wesentlichen 90° verläuft, und daß zwischen den Enden der Entlastungsschlitz (35a) und der Entlastungsfortsätze (33a) ein Steg aus dem Bogenmaterial stehenbleibt und daß die Entlastungsschlitz (35a) und die Entlastungsfortsätze (33a) den Umriß der Schutzstreifen (38) bilden.

2. Tragepackung nach Anspruch 1, dadurch gekennzeichnet, daß die Entlastungsschlitz (35a) an den zweiten Schlitz (35) abgerundet sind, um die Verformung an der 90°-Ecke auf ein Minimum zurückzuführen.

3. Tragepackung nach Anspruch 1, dadurch gekennzeichnet, daß der Steg an jedem Ende der ersten und zweiten Schlitz (33, 33a — 35, 35a) im wesentlichen die gleiche Länge hat wie der anschließende Entlastungsfortsatz (33a) und der Entlastungsschlitz (35a) zusammen, um eine ausreichende Festigkeit und einen sicheren Halt zu gewährleisten.

4. Tragepackung nach Anspruch 3, dadurch gekennzeichnet, daß der Steg an jedem Ende der ersten und zweiten Schlitz (33, 33a — 35, 35a) sich längs der Linie des Entlastungsfortsatzes (33a) mit im wesentlichen 135° zum Ende des Entlastungsschlitzes (35a) erstreckt.

Revendications

1. Porte-article (10) constitué de matériau en feuille du genre enveloppe et destiné à l'emballage d'un certain nombre d'articles (10) disposés en au moins une rangée comprenant:

(a) une découpe oblongue (12) présentant des lignes de pliage (15, 22, 24) pour former un panneau de dessus (14), deux panneaux latéraux (16) et des premier et deuxième panneaux de fond de fermeture (21, 23) conçus pour se chevaucher lorsqu'ils sont appliqués sur les articles à emballer;

(b) ledit premier panneau de fermeture (21) comprenant un certain nombre d'unités de verrouillage (40), chaque unité de verrouillage (40) présentant une languette (25) le long du bord transversal terminal (26) dudit premier panneau de fermeture (21), et une patte de verrouillage (39) en alignement longitudinal avec ladite languette;

(c) ledit deuxième panneau de fermeture (23) comprenant un certain nombre de premières et deuxièmes ouvertures transversalement oblongues (33, 35), lesdites premières ouvertures (33) étant voisines et sensiblement parallèles auxdites deuxièmes ouvertures (35) et s'étendant parallèlement et entre lesdites deuxièmes ouvertures (35) et le bord transversal terminal (34) dudit deuxième panneau de fermeture (23), et ledit bord transversal terminal (34) dudit deuxième panneau de fermeture (23) se trouvant, sur ladite découpe, à l'opposé dudit bord transversal terminal (26, 30) dudit premier panneau de fermeture (21);

et dans lequel ledit deuxième panneau de fermeture (23) comprend du matériau de panneau

de fermeture entre lesdites premières et deuxièmes ouvertures (33, 35), ledit matériau formant une bande protectrice (38), une bande protectrice (38) étant en alignement longitudinal avec chaque unité de verrouillage (40); une desdites languettes (25) pouvant être enfilée dans chacune desdites deuxièmes ouvertures (35) de telle sorte que ladite languette (25) se trouve au-dessus dudit deuxième panneau de fermeture (23) lorsque lesdits premier et deuxième panneaux de fermeture (21, 23) sont en chevauchement; et une desdites pattes de verrouillage (39) pouvant être insérée dans chacune premières ouvertures (33) de telle sorte que ladite patte (39) se trouve au-dessus dudit deuxième panneau de fermeture (23) et assure une retenue bord-à-bord avec ladite première ouverture (33); lesdites premières et deuxièmes ouvertures (33, 35) étant des fentes oblongues telles que la bande protectrice (38) s'étend sur toute la largeur entre les deux fentes (33, 35) et recouvre la patte de fermeture (39) le long de l'intérieur dudit porte-article afin de retenir ladite patte de fermeture (39) en retenue verrouillée bord-à-bord et d'assurer une solidité accrue, ledit porte-article étant caractérisé en ce que chacune desdites premières fentes (33) comprend une paire de prolongements de dégagement (33a), un à chaque extrémité de ladite première fente, lesdits prolongements (33a) s'étendant vers ladite deuxième fente (35) voisine à un angle sensiblement égal à 135° à partir de ladite première fente (33); et chacune desdites deuxièmes fentes (35) comprend une paire de fentes de dégagement (35a), une à chaque extrémité de ladite deuxième fente (35), lesdites fentes de dégagement (35a) s'étendant vers ladite première fente (33) voisine à un angle sensiblement égal à 90° à partir de ladite deuxième fente (35); et lesdites fentes de dégagement (35a) et lesdits prolongements de dégagement (33a) se terminant en laissant entre eux un point de matériau de panneau de fermeture, lesdites fentes de dégagement (35a) et lesdits prolongements de dégagement (33a) définissant en outre les contours desdites bandes protectrices (38).

2. Porte-article selon la revendication 1, dans lequel la paire de fentes de dégagement (35a) desdites deuxièmes fentes (35) est arrondie afin de minimiser la fatigue à l'angle de 90°.

3. Porte-article selon la revendication 1, dans lequel ledit pont présent à chaque extrémité desdites premières et deuxièmes fentes (33, 33a — 35, 35a) est sensiblement égal en longueur à la longueur combinée du prolongement de dégagement (33a) et de la fente de dégagement (35a) voisins, afin d'assurer une solidité et un maintien en verrouillage suffisants.

4. Porte-article selon la revendication 3, dans lequel ledit pont présent à chaque extrémité desdites premières et deuxièmes fentes (33, 33a — 35, 35a) s'étend le long de la ligne du prolongement de dégagement (33a) à sensiblement 135° par rapport à l'extrémité de la fente de dégagement (35a).

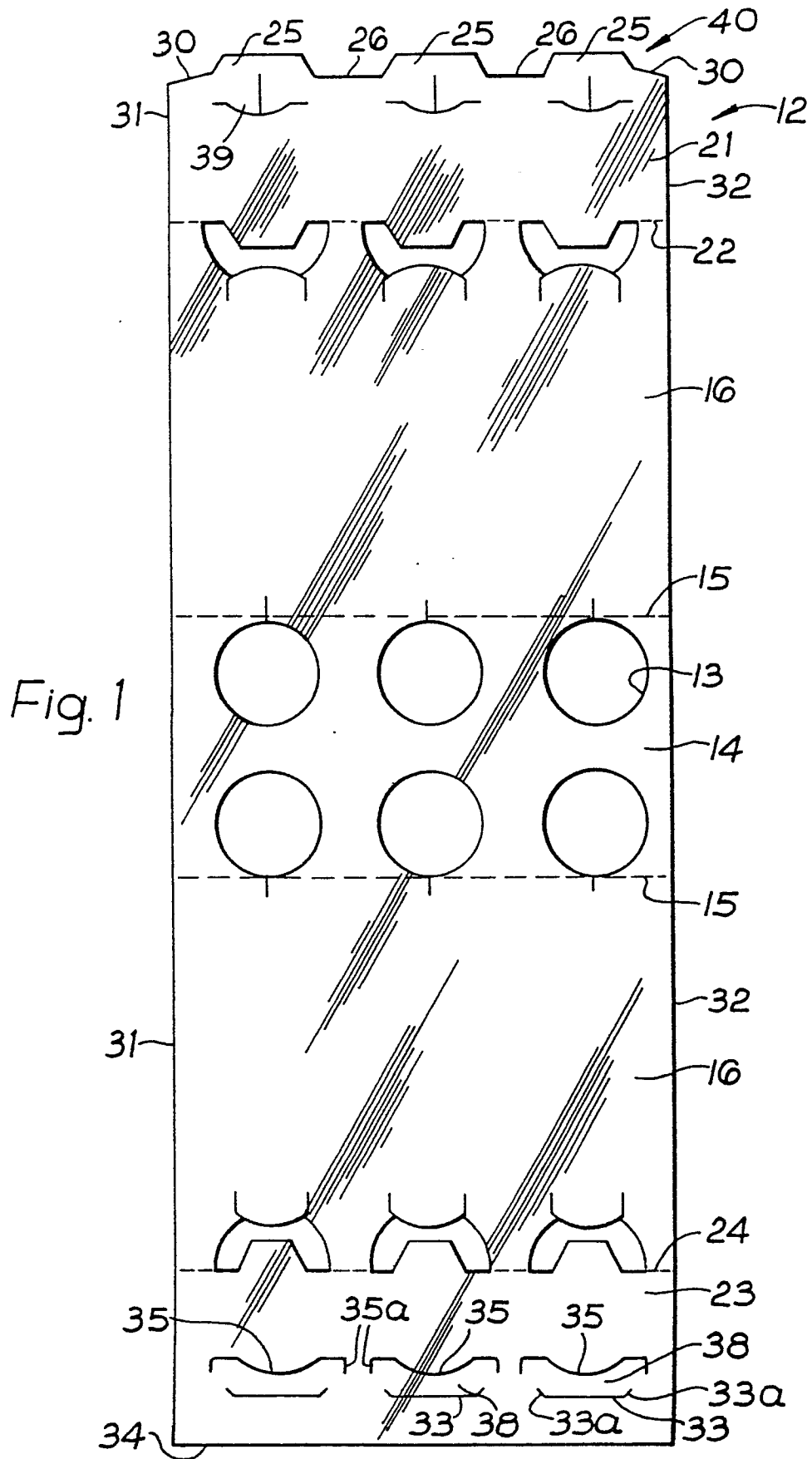

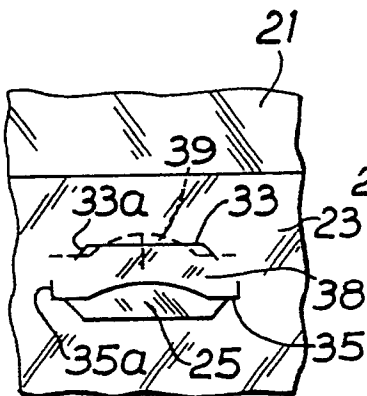
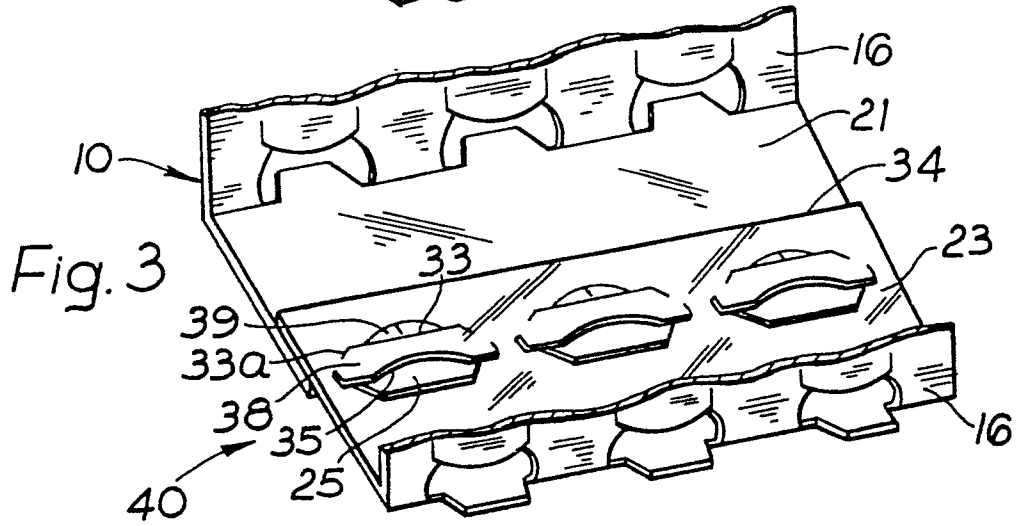
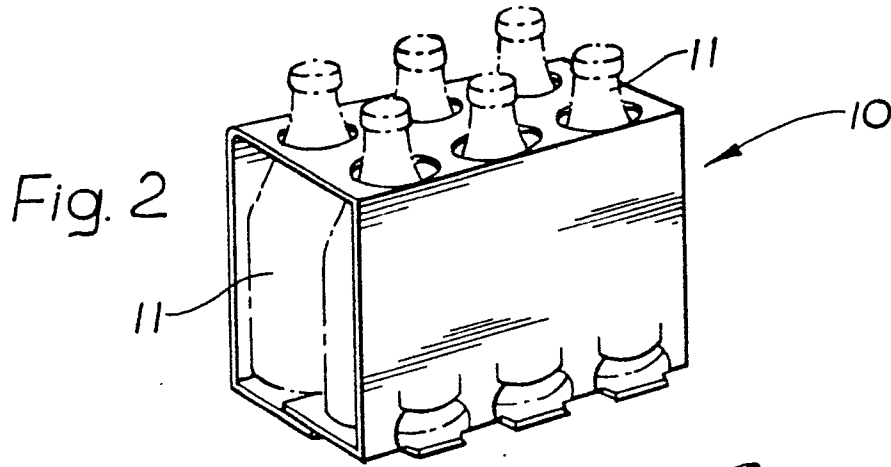

Fig. 4A

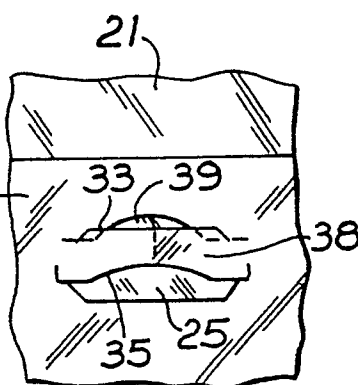

Fig. 4B

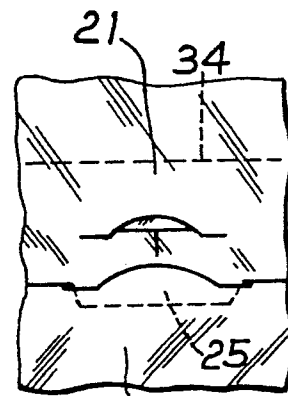

Fig. 4C