

No. 617,480.

Patented Jan. 10, 1899.

J. J. J. DE RYCKE.

STEAM SEPARATOR AND GREASE EXTRACTOR.

(Application filed July 29, 1898.)

(No Model.)

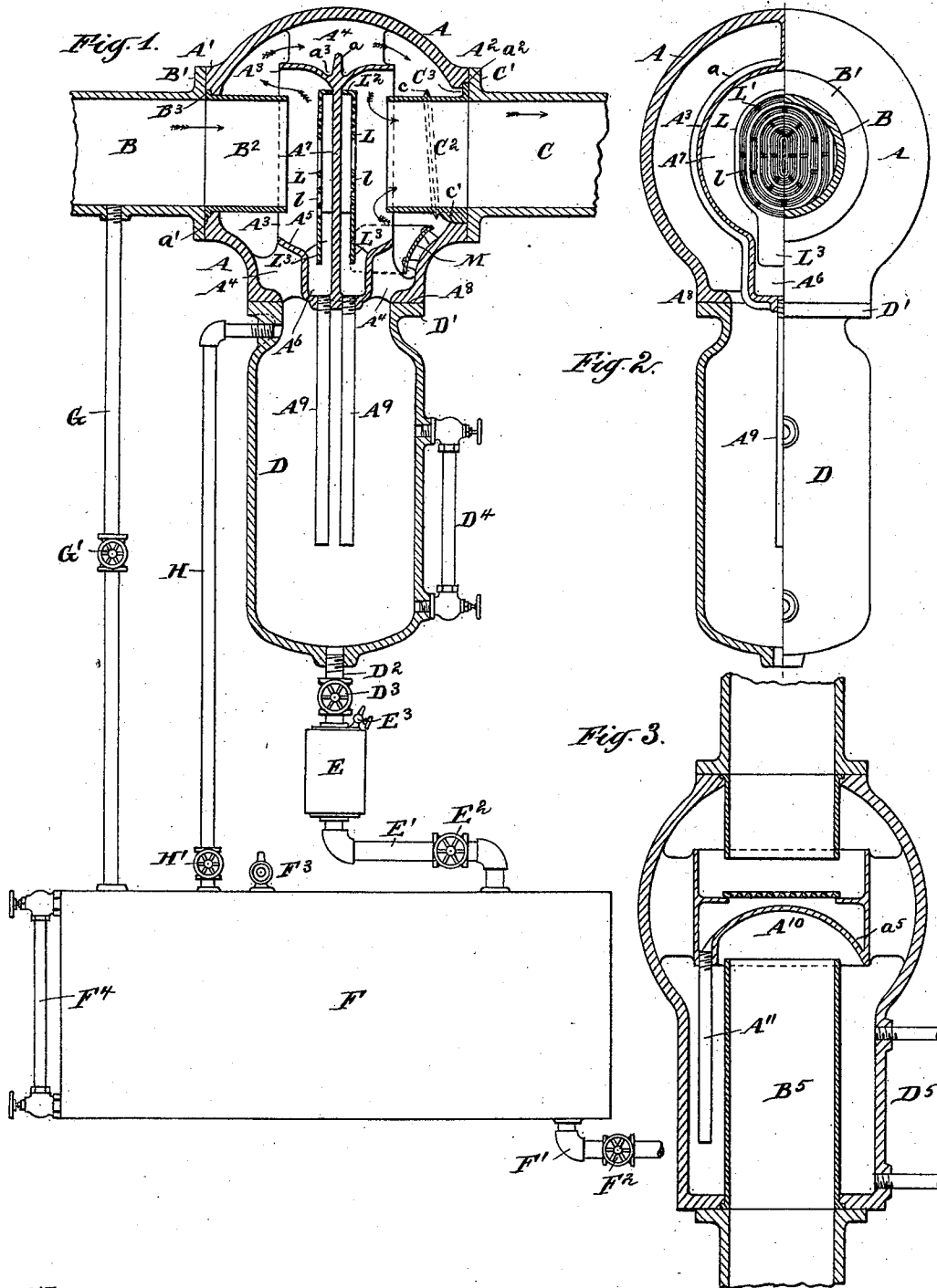

Witnesses:
P. E. Callan.
H. & Grace.

Inventor:
Jules John Joseph de Rycke
by his attorney
Charles R. Searle.

UNITED STATES PATENT OFFICE.

JULES JOHN JOSEPH DE RYCKE, OF NEW YORK, N. Y.

STEAM-SEPARATOR AND GREASE-EXTRACTOR.

SPECIFICATION forming part of Letters Patent No. 617,480, dated January 10, 1899.

Application filed July 29, 1898. Serial No. 687,164. (No model.)

To all whom it may concern:

Be it known that I, JULES JOHN JOSEPH DE RYCKE, a citizen of the United States, residing in New York, (Brooklyn,) in the State of New York, have invented a certain new and useful Improvement in Steam-Separators and Grease-Extractors, of which the following is a specification.

The invention relates to that class of separators and extractors in which a baffle-plate located in the path of the steam causes the latter to be deflected from a direct course and deposit the entrained water and grease upon the plate and adjacent surfaces of the casing, whence it is collected and removed.

The object of the invention is to provide an apparatus that shall be simple in construction, easily and cheaply manufactured and operated, and will efficiently perform the required functions.

It consists of a casing having a centrally-located internal tube provided with a transverse diaphragm or baffle-plate lying in the path of the steam entering through an inlet-pipe arranged opposite to the mouth of the tube and extending inwardly toward the diaphragm. The steam is projected into the tube, strikes the diaphragm, and is reversed in direction and escapes between the tube and casing to the outlet-pipe, leaving its grease and water on the surfaces. The passages are large and practically unobstructed, allowing the steam to flow freely, but compelling it to make the sudden reversal. In the most complete form of the apparatus the steam is forced to make a similar quick change in direction on the opposite side of the diaphragm in entering the outlet-pipe. Provisions are made for collecting any grease or water thus eliminated and lead it through protected passages to a chamber below in communication with a tank in which it is stored, and means are provided for emptying the tank and chamber at intervals and for preventing the ingress of air during the operation or liability of mechanically carrying over any of the entrapped grease or water by a sudden inrush of air through the drain-passages.

The invention also consists in certain details of construction and arrangement of parts to be hereinafter described.

The accompanying drawings form a part of this specification and show the invention as I have carried it out.

Figure 1 is a central vertical section through the separator and extractor arranged to serve on a horizontal steam-pipe, certain portions being shown in elevation. Fig. 2 is a corresponding partial elevation and vertical section of the upper portion of Fig. 1. Fig. 3 is a vertical section showing a modified form adapted to serve on a vertical steam-pipe.

Similar letters of reference indicate like parts in all the figures.

Referring to Figs. 1 and 2, A is a casing, preferably of spherical form, thickened and faced at A' A² on opposite sides to receive the flanges B' C' of the steam-pipes B C, and A³ is a tube located centrally within the casing, joined to the latter above and below by the thin webs A⁴ and having the lower portion dished, as at A⁵, and provided with a depending pocket A⁶. A diaphragm A⁷ extends across the interior of the tube, completely closing it. The tube is preferably so located within the casing that its axial line coincides with the axial line of the inlet and outlet steam-pipes B C and their inward extensions B² C². These extensions or thimbles are provided with narrow flanges B³ C³, received in corresponding counterbores a' a², formed in the faces A' A² and serving to hold the thimbles reliably in line when the pipes B C are bolted in place. Each thimble extends inwardly and lies with its mouth within the tube, and one (the thimble C²) is provided with a fin or ridge c, surrounding it, and a lug c', matching to a corresponding notch in the casing, to insure the proper position in the latter when the parts are assembled. A similar ridge or fin a extends around the tube A³ in the depression a³ at the center and includes the pocket A⁶ in its circuit.

The lower portion of the casing is open and faced, as at A⁸, to receive the flange D' of a chamber D, secured thereto, and within which depend the pipes A⁹, leading downward from the pocket A⁶, one on each side of the diaphragm A⁷. At the lower end of the chamber D is an outlet-pipe D², controlled by a valve D³, leading to an intermediate receiver E, connected by a pipe E', controlled by a valve E², to a tank F, drained by a pipe F' and valve

F². The chamber D and tank F are provided with glass gages D⁴ F⁴, and the intermediate receiver E and tank F are equipped with the air-cocks E³ F³.

5 G is a pipe extending from the upper part of the tank to a point in the inlet-pipe B and is controlled by the valve G'.

The operation of the separator is as follows: Steam under pressure enters through the pipe 10 B and is projected within the tube A³, striking against the diaphragm A⁷, and reversing its direction escapes through the annular space between the thimble B² and the tube, which space is greater in area than the pipe 15 and allows the steam to flow freely in the new direction. A portion of the water will be deposited upon the diaphragm and inner surface of the tube and trickle down the surfaces, to be caught in the pocket A⁶ and led through 20 the pipe A⁹ to the chamber D below and out of the steam-current. The steam is then again forced to reverse by turning the edge of the tube and finds a large open annular passage between the tube and inner face of 25 the casing obstructed only by the thin vertical webs A⁴, supporting the tube and the fin *a* on the exterior of the latter, serving, with the circumferential depression *a*³, to conduct downward any water deposited on its outer 30 face. The direction of the current is again abruptly changed by turning the outer edge of the tube and is projected against the opposite face of the diaphragm and again reversed to enter the thimble C² and outlet-pipe C. 35 The momentum of the water in turning the edge of the tube will project it against the outer surface of the thimble C² and adjacent inner face of the casing, and to prevent such water being again taken up by the current of 40 steam passing below the tube I provide the fin *c*, serving to lead it downward behind the shield M, where it is protected from the current while flowing downward into the chamber. The water deposited within the tube 45 and upon the diaphragm flows to the pocket A⁶ and thence through the pipe A⁹ to the chamber, which when full may be emptied by blowing or trapping out, as usual, through the pipe D².

50 When serving as a grease-extractor with a condensing-engine, the action is in all respects similar to that above described, the difference being that instead of steam under pressure exhaust is passing on its way to the 55 condenser, and it is highly important when thus used that the air be excluded during the emptying operation to avoid impairing or destroying the vacuum. The system of pipes and valves connecting the chamber with the 60 intermediate receiver and tank is intended to serve in successfully performing that function.

When the extractor is in operation, the air-cocks E³ F³ are closed, as is also the valve F², 65 and the valves D³, E², and G' are open to equalize the pressure and allow the grease and water to flow to the tank F and accumu-

late therein until it requires draining. This is effected by closing the valves G' and E², thus cutting off the tank from communication with the condenser, opening the air-cock 70 F³ and valve F² to allow the contents of the tank to escape through the pipe F'. During this period the collection of water and grease continues and accumulates in the intermediate 75 receiver E, which is of such capacity as to take the drainage while the tank is emptying, and is removed therefrom by closing the valve D³ and opening the air-cock E³ and valve E², thus allowing the accumulation to flow into 80 the tank and escape through the pipe F', as before. To again condition the apparatus for service, the valve F² and air-cocks E³ F³ are closed to prevent further ingress of air, and then the valve G' is opened to reestablish an 85 equilibrium of pressure between the tank and receiver E and the condenser. The small quantity of air thus admitted is received in the inlet-pipe B and flows through the extractor with the current of steam and is removed by 90 the air-pump, as usual. The valve D³ is last opened, and as equilibrium has been established the downward flow of the grease and water commences without encountering any 95 opposition.

An advantage of importance is attained by locating the pipe G between the tank and inlet-pipe in that any grease or water carried upward mechanically will be caught by the 100 current of steam before entering the extractor and will be deposited by the action of the latter, and thus prevented from reaching the outlet-pipe C and the condenser.

The pipe H, controlled by the valve H', establishes communication between the upper 105 part of the tank and the chamber D above the water-line and is intended as an alternative device. In the operation of emptying and again restoring equilibrium this pipe may be used instead of the pipe G above de- 110 scribed. The air admitted through it is received in the upper portion of the chamber above any accumulation of grease and water in its lower part, flows to the condenser, and is removed, as before. The pipe H will suc- 115 cessfully perform the functions required; but any water or grease carried by the air will not be so surely eliminated as in the pipe G.

Instead of draining the tank F when it is full, or nearly so, the water and grease may 120 be allowed to accumulate until the tank and intermediate receiver E are filled and a considerable quantity is collected in the chamber D. The operation of emptying is, however, the same as before described. 125

L L are gratings consisting of concentric bars in the same plane separated by V-shaped slots *l*, opening outwardly and joined at intervals by thin webs L'. They are applied one 130 on each face of the diaphragm and held in place by bolts and at a distance from the face of the diaphragm by the lip or flange L². The flange is omitted at the lower portion, so that any water thrown through the grating

may flow downwardly to the pocket. The general outline of the grating is circular or elliptical, and an apron L³, provided at the lower edge, protects the water trickling down the diaphragm behind the grating from the incoming steam.

It will be observed that in passing from the inlet to the outlet pipe the steam is nowhere choked or forced to pass through contracted passages. The flow is free; but the steam is compelled to abruptly reverse its direction or "whip-snap" four times before it escapes, and the water or grease thrown out by momentum against the surfaces is quickly protected and led away without further exposure to the rapidly-moving current.

The apparatus occupies but little space and may be easily and cheaply manufactured.

Modifications may be made in the forms and proportions within wide limits, and parts of the invention may be used without the whole.

When serving as a separator, the pipe G, intermediate receiver E, tank F, and pipe H may be dispensed with and any suitable steam-trap substituted.

The gratings L may be omitted or modified and the general construction of the casing varied.

The form shown in Fig. 3 is designed to serve with a vertical steam-pipe. The chamber D³ incloses the elongated thimble B³, and the diaphragm A¹⁰, arranged horizontally, is domed to provide a gutter a⁵, from which extends a pipe A¹¹, leading the water and grease to the chamber. The drain-pipes are attached at the side, as shown, and may lead to an intermediate receiver and tank similar to the construction shown in Fig. 1.

I claim—

1. In an apparatus of the character set forth, a casing, an inclosed tube supported in the casing and separated therefrom on all sides to allow free passage of the steam, a diaphragm extending transversely of the tube, an inlet-pipe to said casing adapted to project its current within said tube and against said diaphragm, an outlet-pipe from said casing on the opposite side of said diaphragm, and means for collecting and removing any water or grease deposited upon the surfaces, all combined and arranged to serve substantially as herein specified.

2. In an apparatus of the character set forth, a casing, an inclosed tube supported in said casing and separated therefrom on all sides to allow free passage of steam, a diaphragm extending transversely of the tube, an inlet-pipe to said casing adapted to project its current against said diaphragm, an outlet-pipe extending within said casing on the opposite side of said diaphragm and toward the latter, and means for collecting and removing any grease or water deposited upon the surfaces, all combined and arranged to serve substantially as herein specified.

3. In an apparatus of the character set forth, a casing, an inclosed tube supported in

the casing and separated therefrom on all sides to allow free passage of steam, a pocket at the lower portion of said tube, a diaphragm extending transversely of the latter, inlet and outlet pipes extending into said casing and terminating within the open ends of said tube on opposite sides of said diaphragm, a chamber below said casing, and pipes leading from said pocket to said chamber, all combined and arranged to serve substantially as herein specified.

4. In an apparatus of the character set forth, a casing, inlet and outlet pipes, a device located within the casing for separating water and grease from the steam, a chamber in which said water and grease is received, a pipe controlled by a valve leading from a low point in said chamber to a tank at a lower level provided with an air-cock, and a pipe controlled by a valve extending from a high point in said tank to the said inlet-pipe for equalizing the pressure in said inlet-pipe and tank when required, all combined and arranged to serve substantially as and for the purposes herein specified.

5. In an apparatus of the character set forth, a casing, and inlet and outlet pipes, a device adapted to separate the grease and water from the steam, a chamber in which such grease and water is received, an intermediate receiver located below said chamber and provided with an air-cock, a tank located below said receiver and provided with an air-cock, pipes controlled by valves connecting said chamber and receiver and said receiver and tank, a pipe controlled by a valve leading from a low point in said tank, a pipe extending from a high point in said tank to the inlet-pipe, and a valve controlling it, all combined and arranged to serve substantially as herein specified.

6. In an apparatus of the character set forth, a casing and inlet and outlet pipes, a device adapted to separate the grease and water from the steam, a chamber in which such grease and water is received, a pipe controlled by a valve leading from a low point in said chamber to a tank at a lower level provided with an air-cock, and a pipe controlled by a valve leading from a high point in said tank to a high point in said chamber above the water-line in the latter, all combined and arranged to serve substantially as herein specified.

7. The casing A, tube A⁸ therein and diaphragm A⁷, in combination with the pipes B C secured to said casing, the thimbles B² C² forming inward extensions of said pipes, and the flanges B' C' thereon received in counterbores in said casing and held by said pipes, all substantially as herein specified.

8. The casing A, pipes B C and thimbles B² C², the fin c on the latter, and the chamber D below said casing, in combination with the tube A⁸, pocket A⁶ thereon, diaphragm A⁷ closing said tube and dividing said pocket, the fin a on said tube, and the pipes A⁹ ex-

tending from said pocket to said chamber, all substantially as herein specified.

9. The casing A, pipes B C and thimbles B²C², and the chamber D below said casing, in combination with the tube A³, pocket A⁶ and diaphragm A⁷, pipes leading from said pocket to said chamber, and the shield M adapted to protect water and grease traveling behind it, from the currents of steam, all substantially as herein specified.

10. The casing A, tube A³ therein and diaphragm A⁷ completely closing said tube, in combination with the inlet and outlet pipes B C and the thimbles B²C² extending within said tube, the pocket A⁶ on the latter, the chamber D below said casing, and the pipes A⁹ extending from said pocket, one on each side of said diaphragm, to said chamber, all substantially as herein specified.

11. The casing A, tube A³ therein and diaphragm A⁷, in combination with the inlet and outlet pipes B C arranged in line with said tube and on opposite sides of said diaphragm, and the grating L applied on said diaphragm in the path of the current of steam projected thereon, all substantially as herein specified.

12. The casing A, tube A³ therein and diaphragm A⁷, in combination with the inlet and outlet pipes arranged in line with said tube and on opposite sides of said diaphragm, the gratings L applied on said diaphragm in the path of the currents of steam projected thereon, and the flange L² and apron L³, all substantially as herein specified.

13. The casing A, tube A³ therein, diaphragm A⁷ completely closing said tube, the inlet and outlet pipes B C, and thimbles B²C² extending therefrom into said tube from opposite sides of said diaphragm, the pocket A⁶, pipes A⁹, chamber D, connected intermediate receiver E and tank F below, and the pipe G connecting said tank to said inlet-pipe, all combined and arranged to serve substantially as and for the purposes herein specified.

In testimony that I claim the invention above set forth I affix my signature in presence of two witnesses.

JULES JOHN JOSEPH DE RYCKE.

Witnesses:

J. H. GOLDEY,
CHARLES R. SEARLE.