

Nov. 10, 1931.

L. M. HOPKINS

1,831,005

BURGLAR ALARM

Original Filed Feb. 25, 1929 2 Sheets-Sheet 1

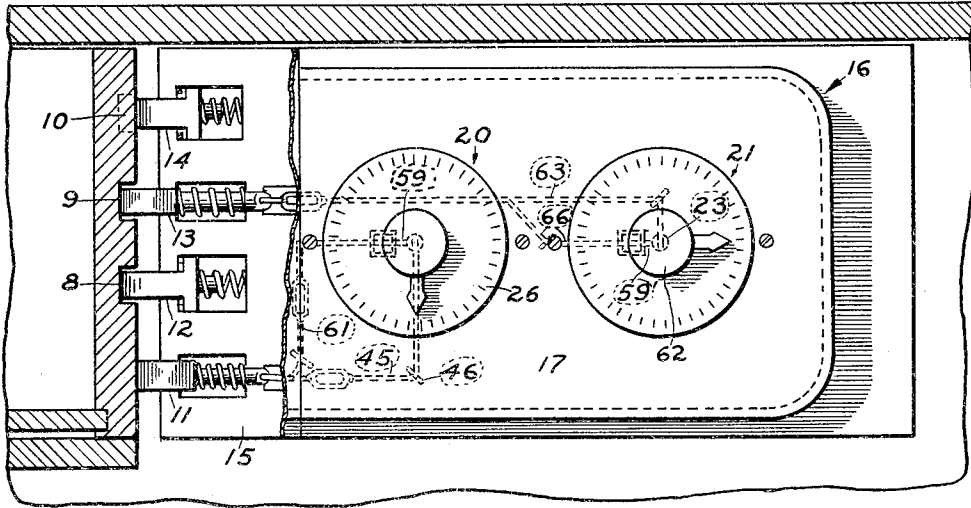

Fig. 1.

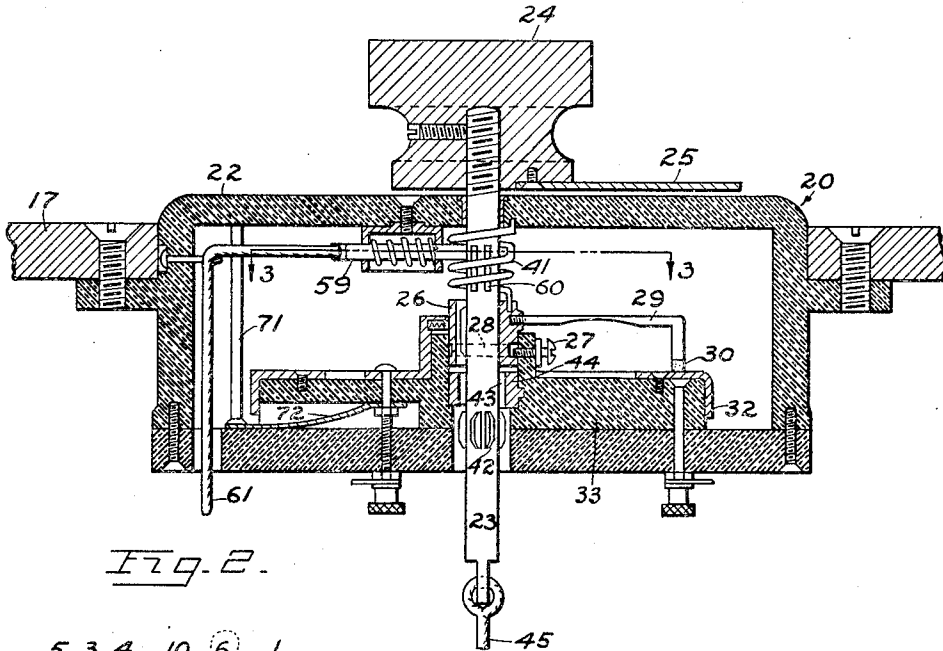

Fig. 2.

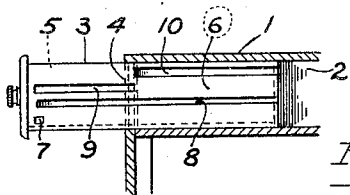

Fig. 3.

INVENTOR.
LESTER M. HOPKINS
BY *Munn & Co.*
ATTORNEYS.

Nov. 10, 1931.

L. M. HOPKINS

1,831,005

BURGLAR ALARM

Original Filed Feb. 25, 1929 2 Sheets-Sheet 2

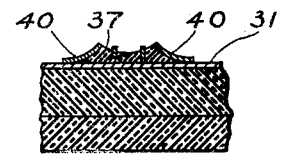
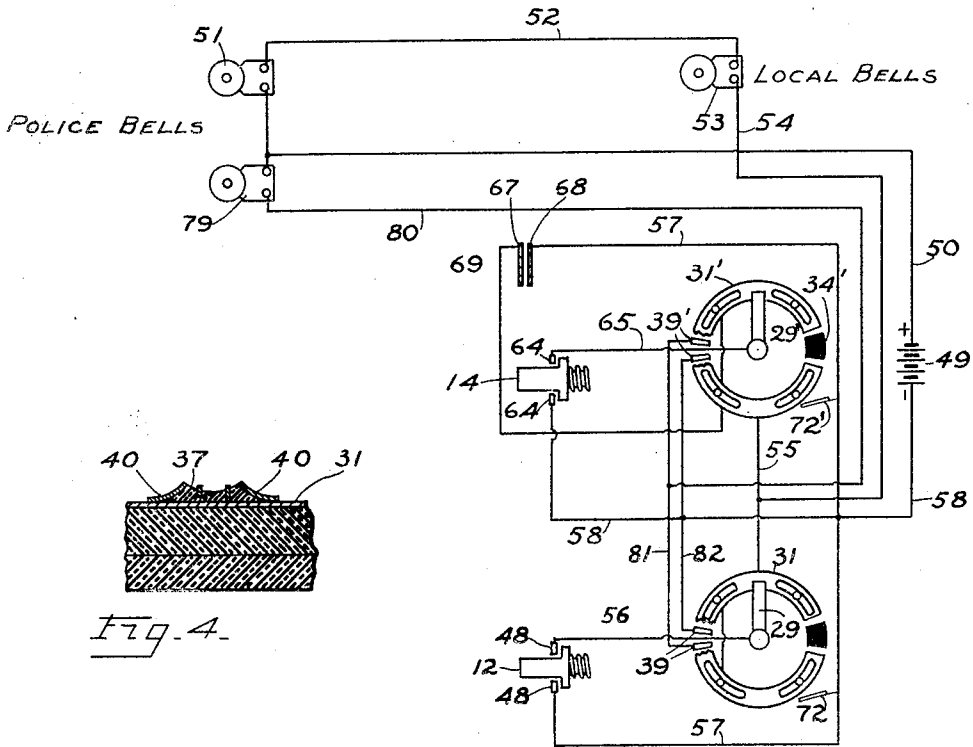

Fig. 4.

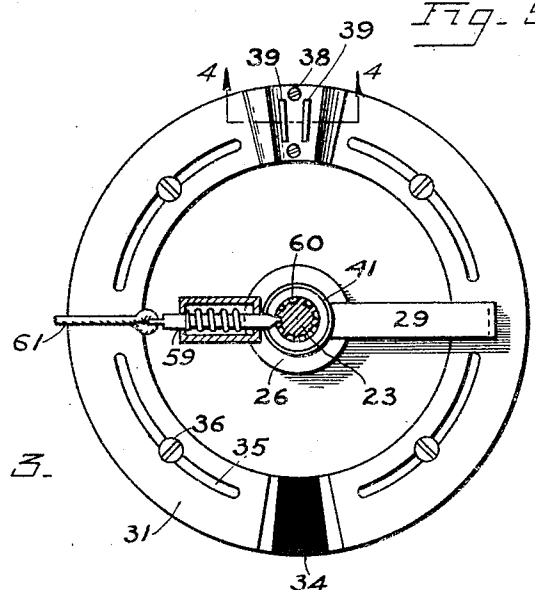

Fig. 3.

Fig. 5.

INVENTOR.
 LESTER M. HOPKINS
 BY *Munn & Co.*
 ATTORNEYS.

UNITED STATES PATENT OFFICE

LESTER M. HOPKINS, OF HAWTHORNE, NEVADA

BURGLAR ALARM

Original application filed February 25, 1929, Serial No. 342,479. Divided and this application filed April 18, 1930. Serial No. 445,439.

My invention relates to improvements in burglar alarms and it consists in the combinations, constructions and arrangements hereinafter described and claimed.

5 This case is a division of my co-pending application Serial No. 342,479 filed February 25, 1929. In the co-pending application I have set forth the switch and the burglar alarm system and am claiming the specific system. In the present case I am again setting forth the switch and am claiming it.

Other objects and advantages will appear as the specification proceeds, and the novel features of the device will be particularly pointed out in the claims hereto annexed.

My invention is illustrated in the accompanying drawings, in which:

15 Figure 1 is a front elevation of a part of the device, portions being broken away for clarity,

Figure 2 is a transverse section through one of the dial switches,

Figure 3 is a section along the line 3—3 of Figure 2,

25 Figure 4 is a section along the line 4—4 of Figure 3,

Figure 5 is a wiring diagram, and

30 Figure 6 is a side elevation of the drawer showing it partially received in a table or desk.

In carrying out my invention, I make use of a table 1 having a drawer-receiving compartment 2 therein (see Figure 6). A drawer 3 is slidably disposed in the compartment and has a partition 4 separating the coin receptacles 5 from a bill-holding compartment 6.

40 Figures 1 and 6 show how the drawer 3 is provided with a recess 7 and grooves 8, 9 and 10 in the outer surface of one of its side walls. Spring-pressed plungers 11, 12, 13 and 14 ride in the recess and grooves, and these plungers are carried by a base 15 of a casing 16 which in turn is supported by the table 1.

45 Two dial switches 20 and 21 are carried by the front 17, and a description of one will suffice for both. The switch 20, for example, (see Figure 2) has a housing 22 secured to the front 17. Within the housing I mount a shaft 23. This shaft is rotated by means of

a knob 24, and this same knob can move the shaft longitudinally. A pointer 25 is carried by the knob and rides over graduations 26 (see Figure 1) on the face of the housing 22.

A collar 26 is keyed to the shaft 23 so as to be rotated therewith. A set screw 27 rides in a groove 28 in the collar and prevents longitudinal movement of it when the shaft is moved longitudinally. A switch arm 29 is carried by the collar and has a brush 30 that rides over a split circular contact strip 31 (see Figure 3). The outer marginal edge of the strip is bent downwardly for forming a flange 32 (see Figure 2). An insulating block 33 carries the strip 31 and has an insulating portion 34 (see Figure 3) disposed between the split ends of the strip 31 for a purpose hereinafter described. The strip 31 is adjustable and is provided with arcuate slots 35 and fastening screws 36 for this purpose.

A turning of the knob 24 will cause the brush 30 to ride over the strip 31, and will also cause it to ride over the insulating portion 34. I also provide an insulating block 37 of the shape shown in Figure 4, and secure this block on the strip 31 by screws 38 (see Figure 3). These screws do not have an electrical connection with the strip 31, but pass through openings in the strip. Neither do terminals 39 carried by the insulating block 37 (see Figure 3) have any electrical connection with the strip 31. The block carries curved conductors 40 that do have an electrical connection with the strip 31. The purpose of the block 37 and the terminals 39 will be hereinafter set forth.

The switch arm 29 is swung back into the full-line position shown in Figure 3 by a torsional spring 41 (see Figure 2), this spring having its ends secured to the housing 22 and to the collar 26. The shaft 23 has fins 42 that ride into grooves 43 in a fixed collar 44, and this prevents the rotation of the shaft 23 and the knob 24 when the latter is pulled outwardly.

It is best now to connect the dial 20 with the operation of the drawer 3 so as to clear up the functioning of the device as the specification proceeds. When the drawer is in

closed position, the spring plunger 11 (see Figure 1) is received in the recess 7 (see Figure 6). The drawer cannot be opened until this plunger 11 is removed from the recess. Figure 1 shows a cable 45 as being connected to the inner end of the plunger 11, and further shows this cable as being passed through an eyelet 46, and as having its end connected to the shaft 23 (see Figure 2). A pulling of the knob 24 outwardly will move the cable for pulling the plunger 11 into retracted position. The drawer 3 may now be opened. As soon as this takes place, the spring-pressed plunger 12 will enter the groove 8 and will close contact terminals 48 (see the wiring diagram in Figure 5). Should the operator have failed to place the switch arm 29 upon the neutral portion 34, a circuit will be closed from a source of current 49 through a wire 50, police bell 51, wire 52, local bell 53, wire 54, wire 55, conductor strip 31 (shown separated at its top for clarity), switch arm 29, wire 56, one contact terminal 48, plunger 12, the other contact terminal 48, wire 57, wire 58, and back to the source of current. This will sound the bells 51 and 53, which will give the general alarm.

If the switch arm 29 has previously been placed upon the neutral plate 34, the knob 24 may be moved outwardly and the drawer 3 opened without sounding the alarm. The shaft 23 is held against being swung back into normal position by the spring 41, and is accomplished by a spring-pressed pin 59 (see Figure 2) that enters any one of a number of slots 60 in the shaft 23. The pin is normally held in retracted position by a cable 61 (see Figure 2) that is connected to the plunger 11 (see Figure 1). The spring on the plunger is stronger than the spring on the pin, and therefore when the plunger is in extended position the pin will be held in retracted position. When the plunger is held in retracted position by the side of the drawer 3, the pin will enter one of the slots 60 and will hold the arm 29 on the neutral portion 34. The arm will remain in this position until the drawer 3 is again closed.

It will be noted that the groove 8 in which the plunger 12 rides extends clear to the back of the drawer. The groove 9 receives the stop plunger 13, and this plunger permits the drawer to be opened part way, a distance sufficient to expose the money trays 5. In order to gain access to the compartment 6, it is necessary to actuate a knob 62 of the dial switch 21. The parts in this switch will have the same numbers as the parts in the dial switch 20. For clarity, these numbers will be primed. The shaft 23' is connected by a cable 63 (see Figure 1) with the plunger 13. An outward pull upon the knob 62 will free the plunger 13 and permit the drawer to be opened further. As soon as this takes

place, the plunger 14 will drop into the groove 10 (see Figure 6) and will close contact points 64 (see Figure 5). Should the operator have failed to place the switch arm 29' (see Figure 5) on the neutral portion 34', a circuit will be closed from the source of current 49 through the wire 50, bell 51, wire 52, bell 53, wire 54, wire 55, strip 31', switch arm 29', wire 65, one of the contacts 64, plunger 14, the other contact 64, the wire 58, and back to the source of current. This will ring the general alarm consisting of the bells 51 and 53. The placing of the switch arm 29' on the portion 34' will prevent this alarm from being sounded.

The switch arm 29' is held on the neutral point 34' by a spring-pressed pin 59' (see Figure 1) that functions in the same manner as the pin 59. The pin 59' is connected by means of a cable 66 to the cable 63 so that a movement of the plunger 13 rearwardly will cause the pin 59' to hold the shaft 23' against movement.

Various safety precautions are shown in the drawings for turning in an alarm should the device be tampered with. For example, the front 17 has two spaced-apart conductor screens 67 and 68 (see Figure 5) that are connected by wires 69 and 57 to the strip 31' and the wire 58 respectively. In case the front 17 is broken in, the screens 67 and 68 would contact with each other and would close the wires 54 and 58, which in turn would close a circuit through the source of current and the bells 51 and 53.

In case the housings 22 and 22' are tampered with, a pin 71 (see Figure 2) will be freed, and this will permit a spring conductor 72 to contact with the strip 31 and to close a circuit. In Figure 8 I show the conductor strips 72 and 72' as being connected to the wire 57, and when these strips contact with the strips 31 and 31' the wires 54 and 58 are electrically connected together, which results in the ringing of the bells 51 and 53.

If the person using the device wishes to send in an alarm to the police station without ringing the bells 51 and 53, he can swing either of the switch arms 29 or 29' onto contacts 39—39 or 39'—39'. This will cause a current to flow from the battery 49 through the wire 50, a police bell 79, a wire 80, a wire 81, contacts 39—39 or 39'—39', wire 82, wire 58, and back to the source of current. The switch arms 29 or 29' merely act as electrical bridges between the contacts 39—39 or 39'—39'.

Although I have shown and described one embodiment of my invention, it is to be understood that the same is susceptible of various changes, and I reserve the right to employ such changes as may come within the scope of the invention as claimed.

I claim:

1. A dial switch comprising a housing, a

70

75

80

85

90

95

100

105

110

115

120

125

130

shaft rotatably mounted therein, a knob for rotating said shaft and for moving it longitudinally, a switch arm keyed to said shaft, a conductor strip lying in the path of said switch arm, a spring for moving said switch arm into contact with the conductor strip, said spring holding said switch arm in place while the shaft is moved longitudinally, an insulated portion disposed in the path of said switch arm, and means for holding said switch arm on said insulated portion.

2. In a dial switch, an arcuate conductor strip, an insulating portion disposed between the ends of said strip, an insulating block disposed on said strip and carrying terminals, a switch arm movable over said strip, insulating portion, and terminals, said block and terminals being removably secured to said arcuate strip.

3. A dial switch comprising a casing, a shaft rotatably mounted therein, a knob secured to said shaft, a split conductor ring concentrically mounted with respect to said shaft, a switch arm feathered to the shaft and contacting with the ring, spring means for yieldingly holding the arm in contact with the ring, said shaft being movable longitudinally with respect to said arm, and means for preventing a swinging of the arm when the shaft is moved into extended position.

LESTER M. HOPKINS.

35

40

45

50

55

60

65