



US 20050217691A1

(19) **United States**

(12) **Patent Application Publication**
Petit

(10) **Pub. No.: US 2005/0217691 A1**

(43) **Pub. Date: Oct. 6, 2005**

(54) **APPLICATOR DEVICE FOR PASTE PRODUCTS, TYPICALLY COSMETICS**

(75) Inventor: **Robert Petit, Cluny (FR)**

Correspondence Address:
DENNISON, SCHULTZ, DOUGHERTY & MACDONALD
1727 KING STREET
SUITE 105
ALEXANDRIA, VA 22314 (US)

(73) Assignee: **Techpack International**

(21) Appl. No.: **11/080,660**

(22) Filed: **Mar. 16, 2005**

(30) **Foreign Application Priority Data**

Apr. 2, 2004 (FR)..... 04/03502

Publication Classification

(51) **Int. Cl.⁷ A46B 11/00**

(52) **U.S. Cl. 132/320**

(57) **ABSTRACT**

Applicator device (1) for a paste product, typically a cosmetic, typically intended to cooperate with a receptacle containing the paste product, contains a longitudinal body (2) with an axial direction (20), the longitudinal body (2) including an axial rod (3) and an applicator (4) fixed to the axial rod (3). The axial rod (3) is intended to cooperate with a manual gripping means of the applicator device (1), the applicator (4) is capable of sampling a fraction of the product contained in the receptacle, typically by cooperation of the applicator with a wiper, so that it can be applied on a support, usually a part of the body or the face when the product is a cosmetic. The applicator (4) forms a single piece plastic part (4'), typically a molded part made of one or several plastic materials, has a shape factor L/D varying from 2 to 7, where L is the axial length and D is the maximum radial diameter of the applicator (4) or a surrounding volume (40) of the applicator, the axial length L is between 10 and 20 mm, the applicator includes a support (8) and a plurality (5) of radial discontinuities (5') fixed to the support (8), the plurality of radial discontinuities (5) forming a plurality (6) of cavities and/or a plurality (7) of elements in relief (7') such that the device offers a high contact surface area S with the product and a high retention volume V of the product.

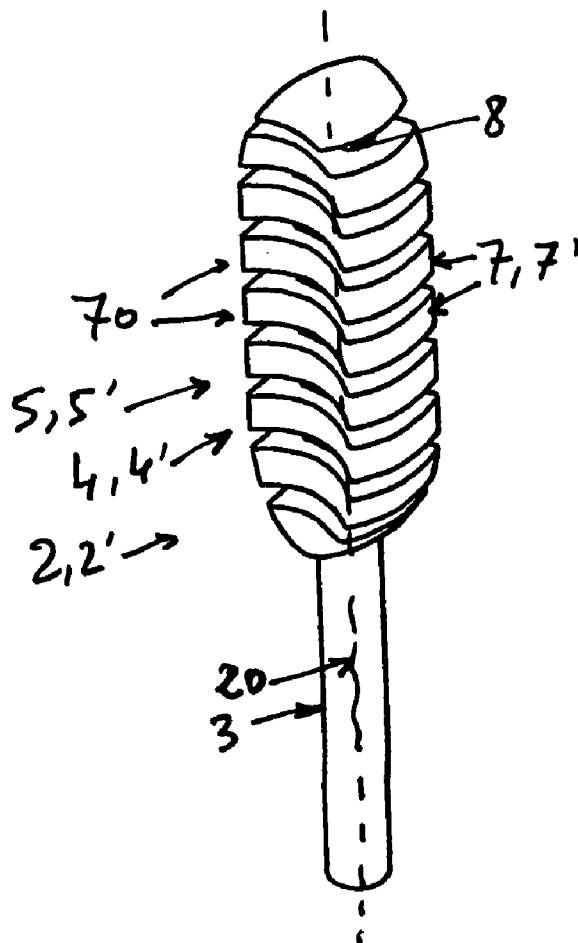

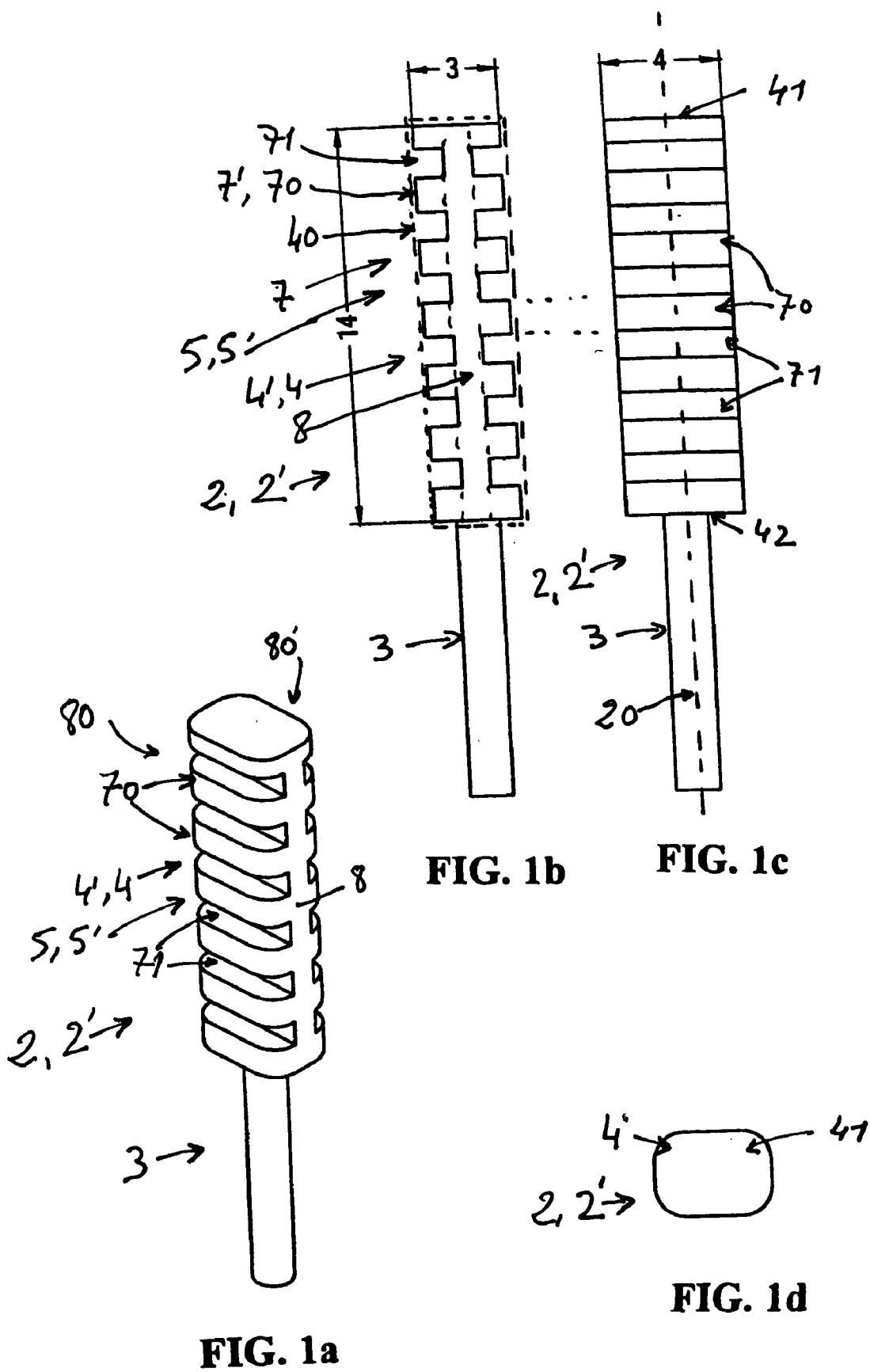

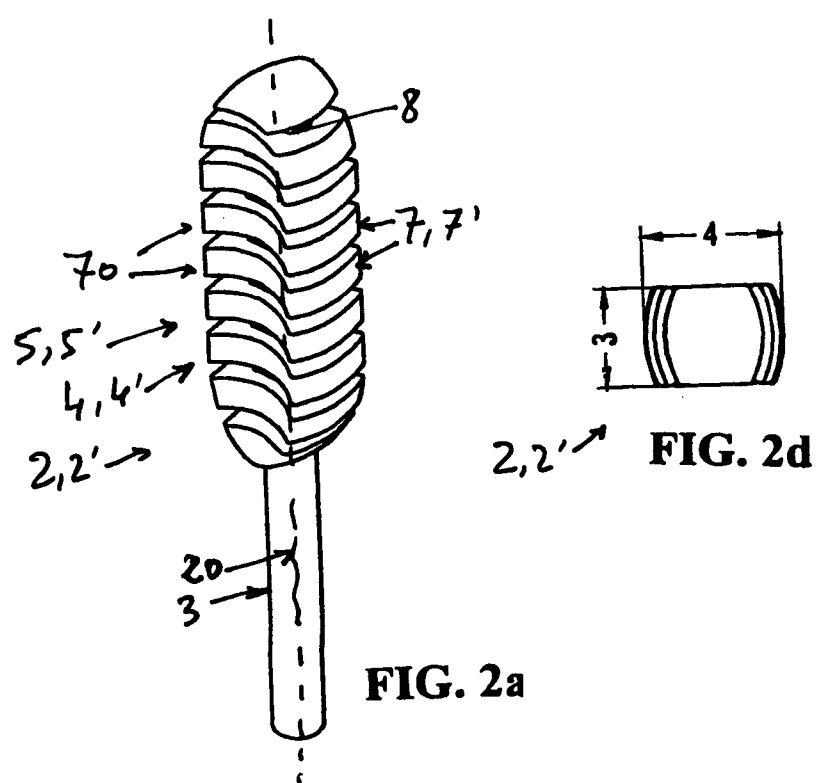
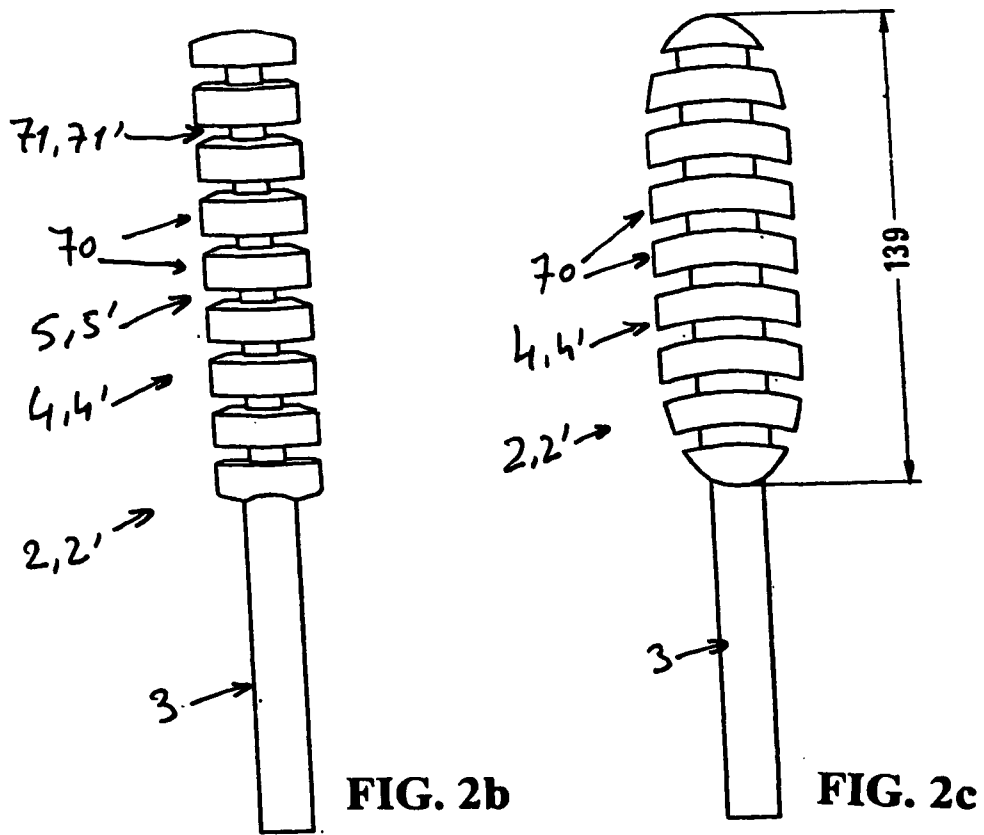

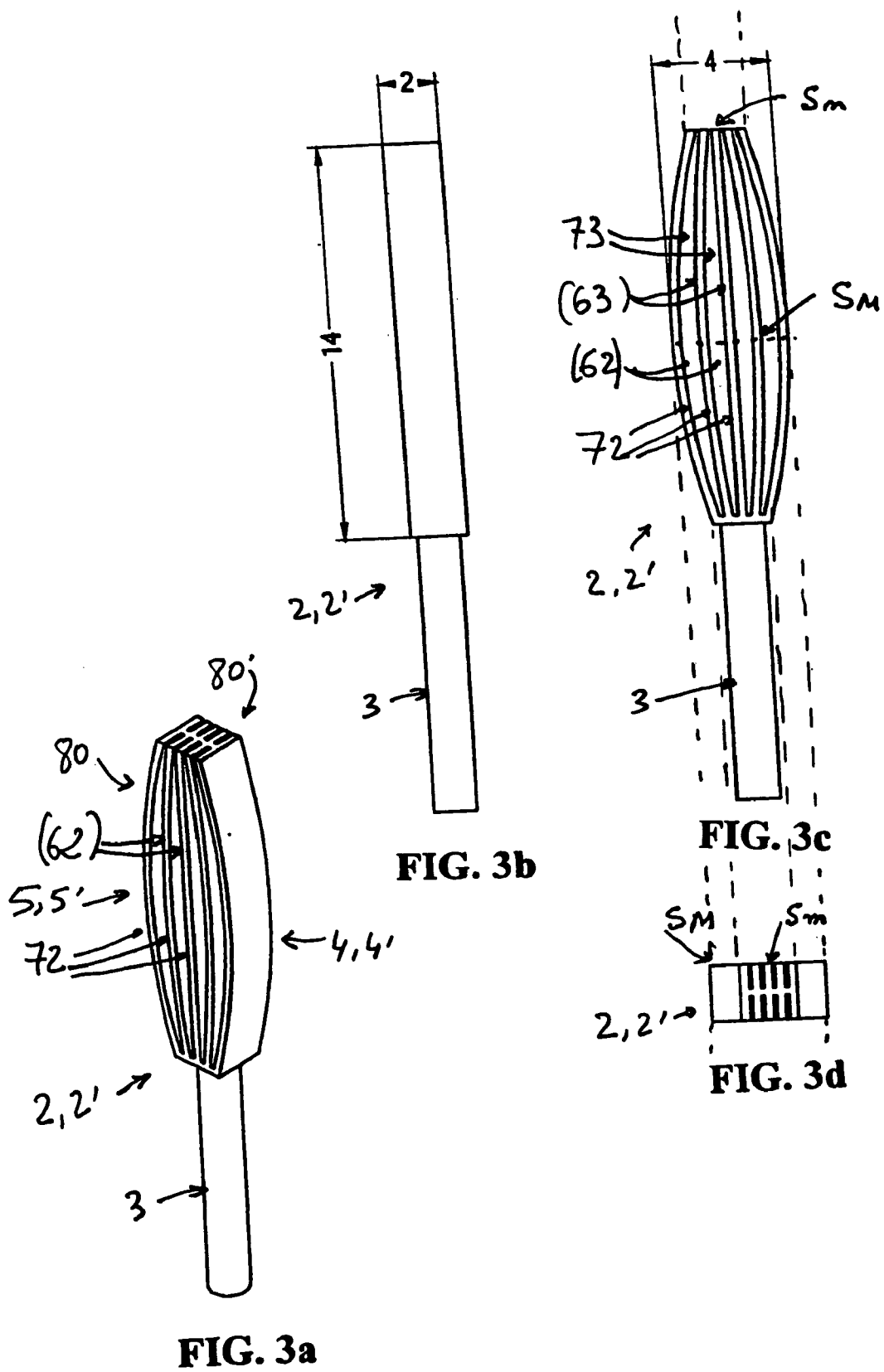

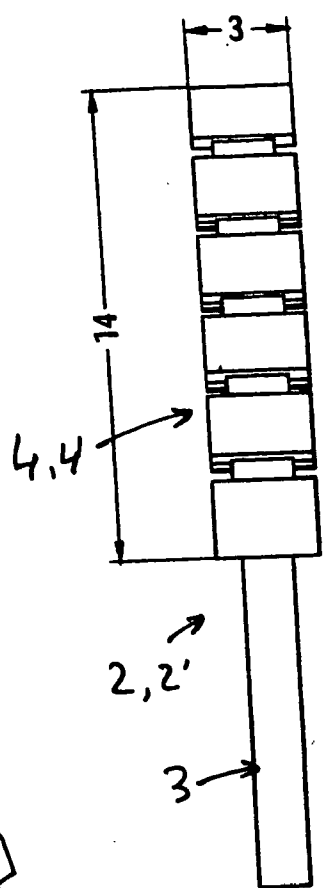

FIG. 4b

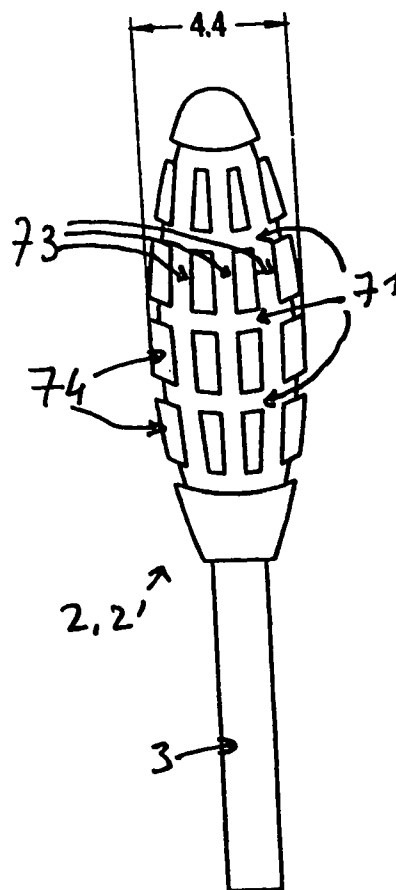

FIG. 4c

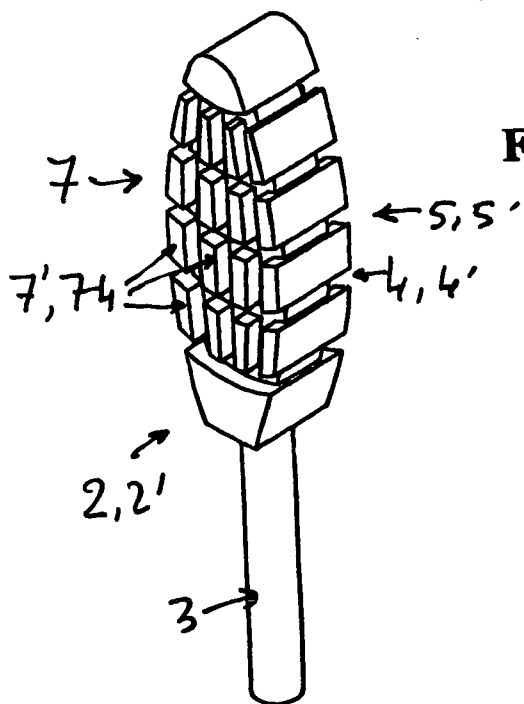
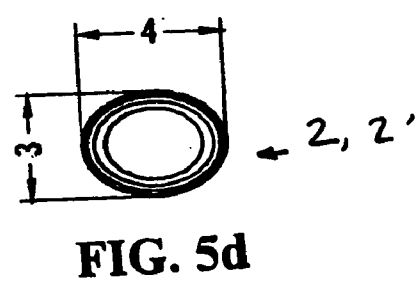
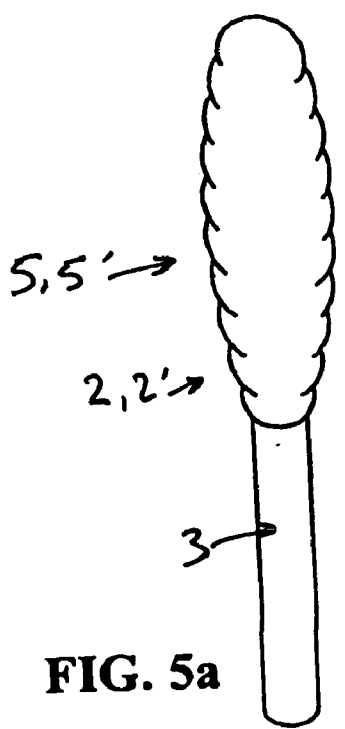
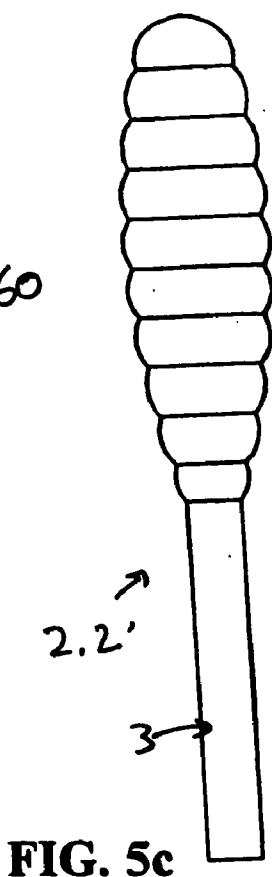
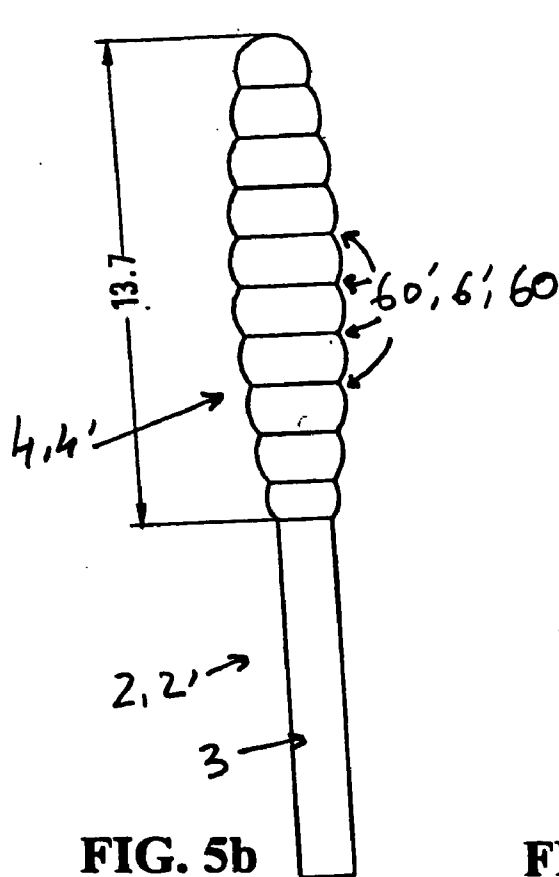

FIG. 4a



FIG. 4d



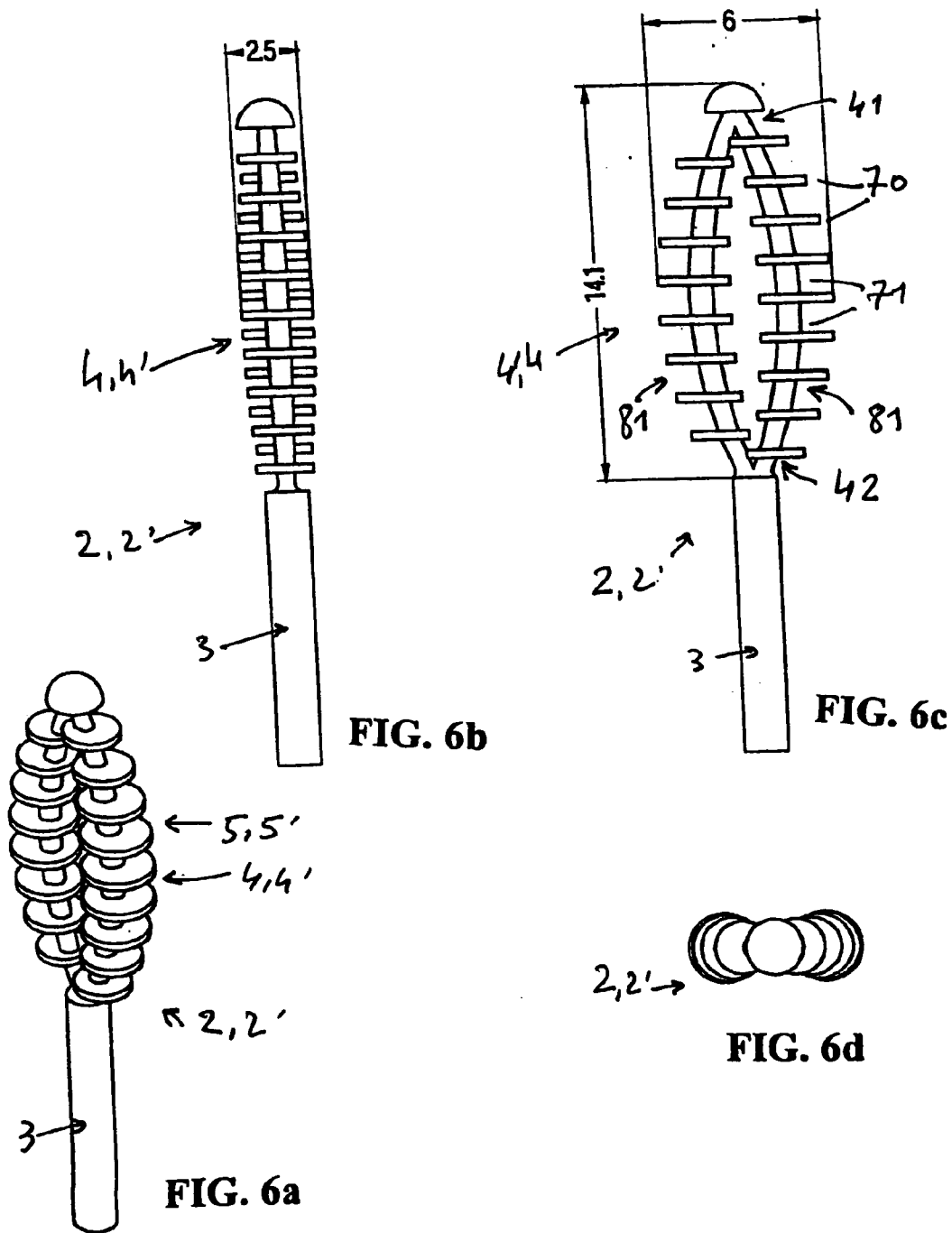

FIG. 6b

FIG. 6c

FIG. 6a

FIG. 6d

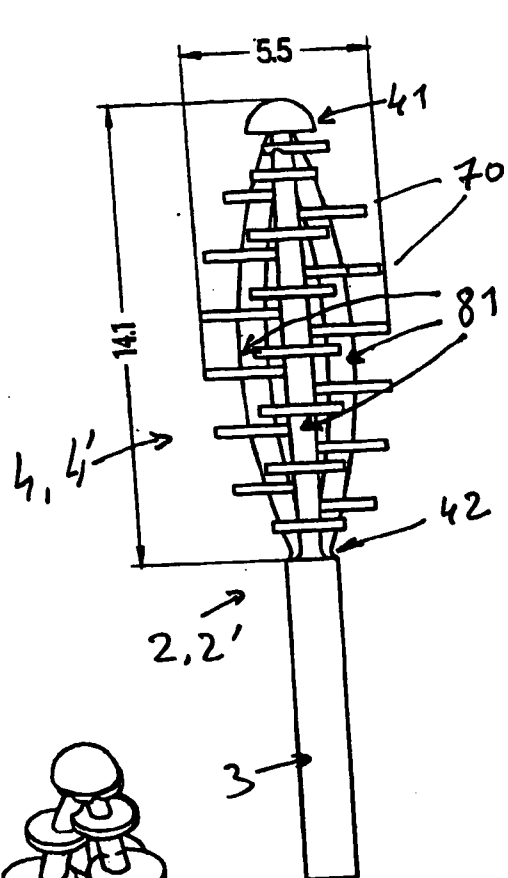

FIG. 7b

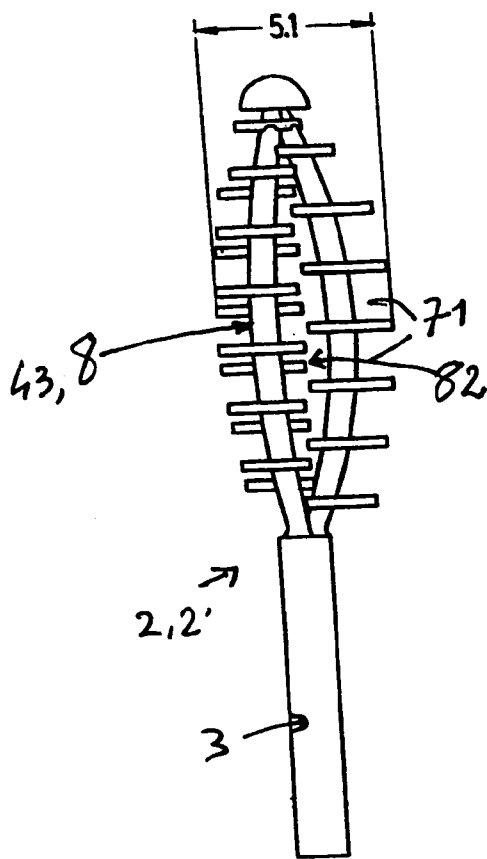

FIG. 7c

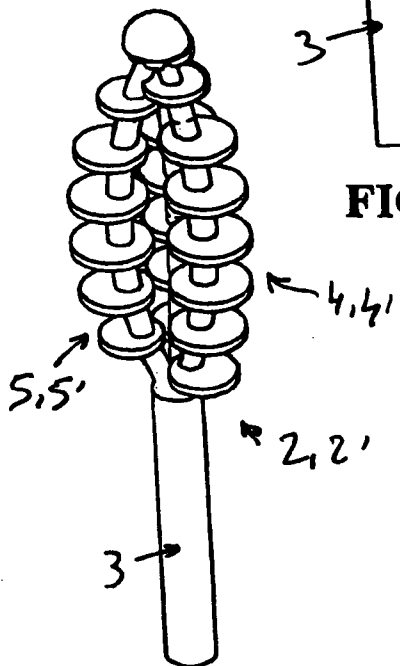

FIG. 7a

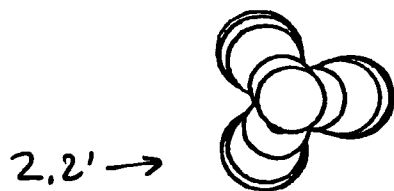
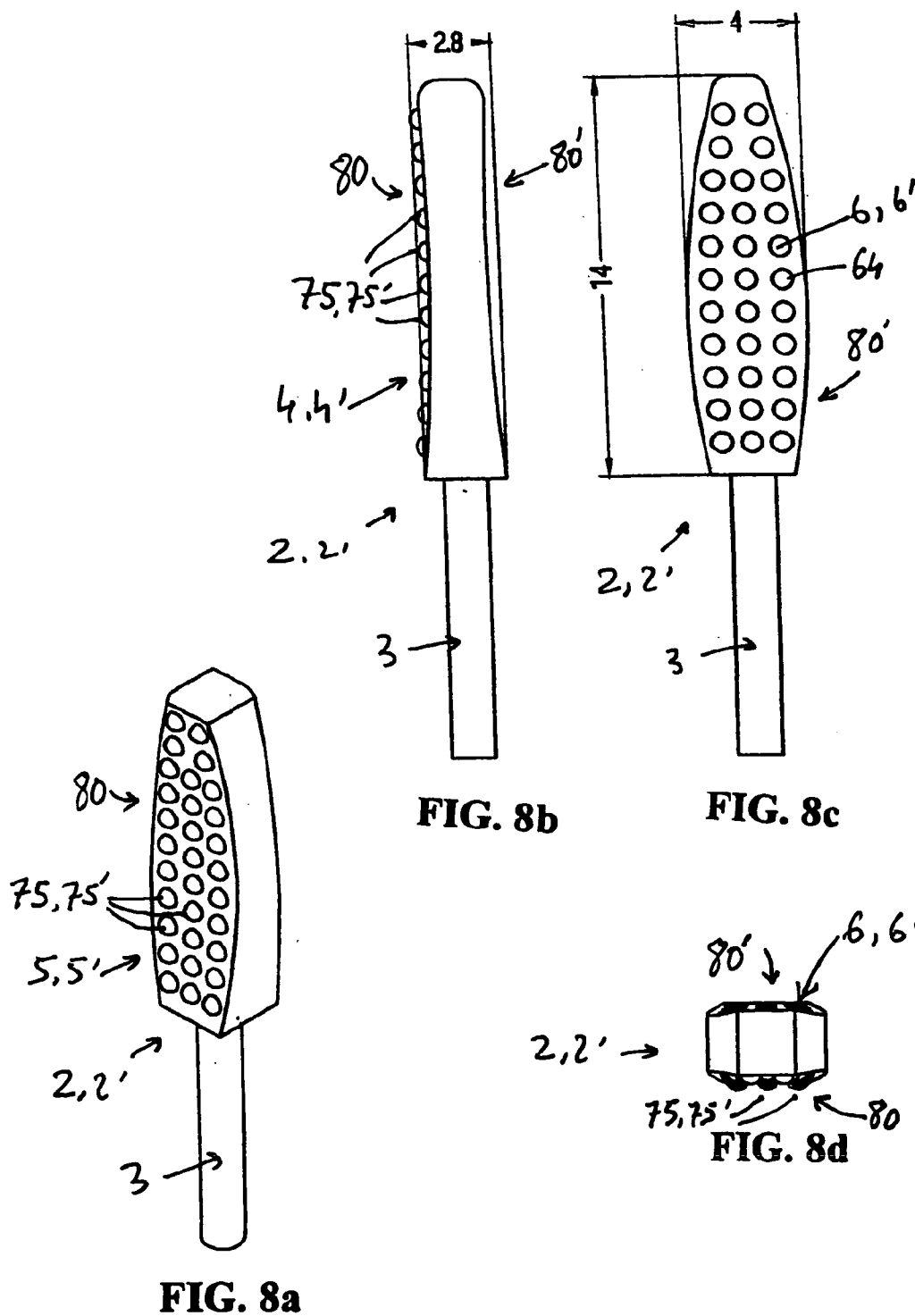

FIG. 7d



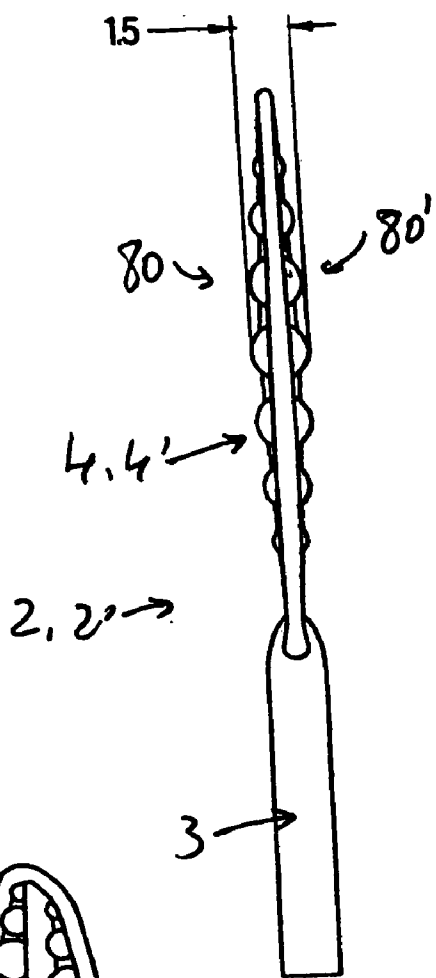

FIG. 9b

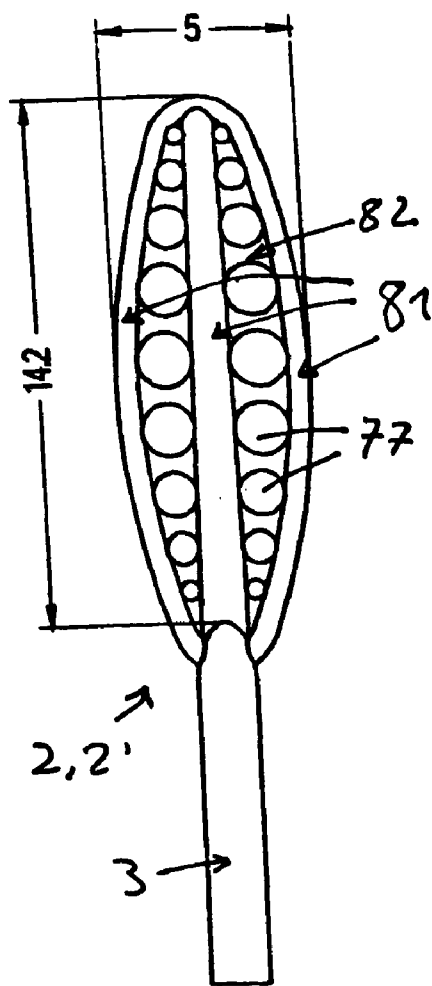

FIG. 9c

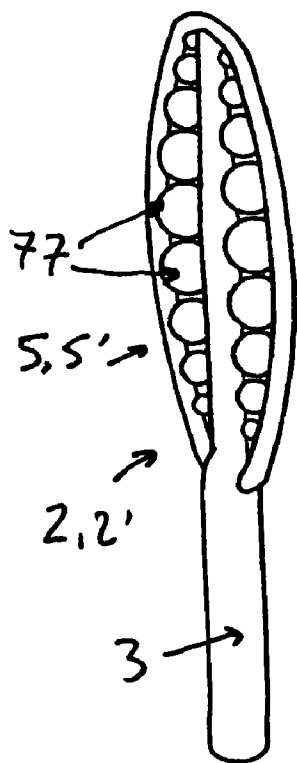

FIG. 9a

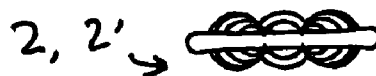

FIG. 9d

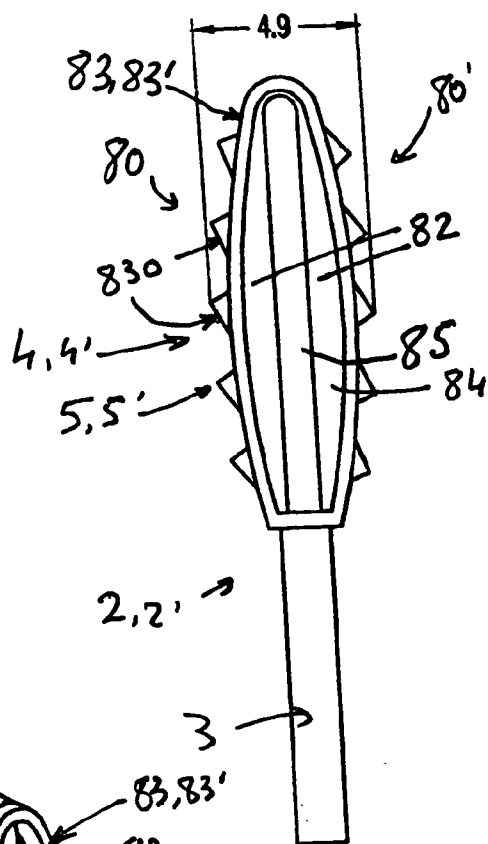

FIG. 10b

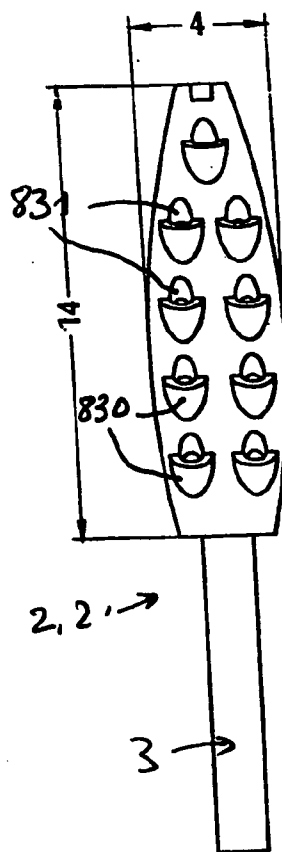

FIG. 10c

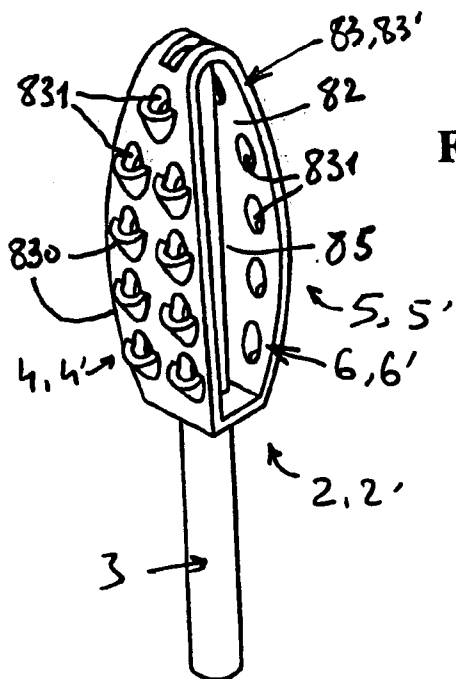

FIG. 10a

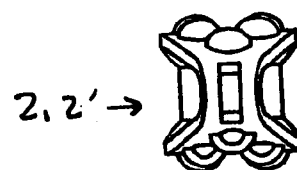

FIG. 10d

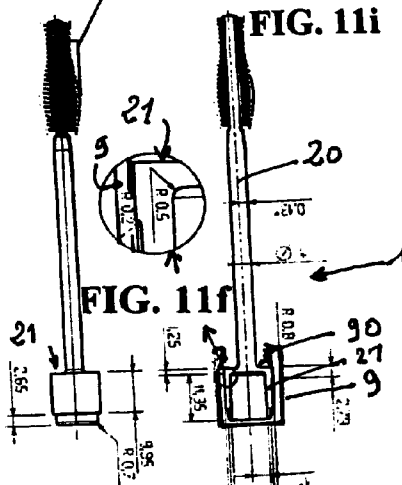
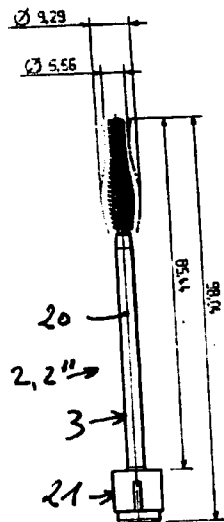
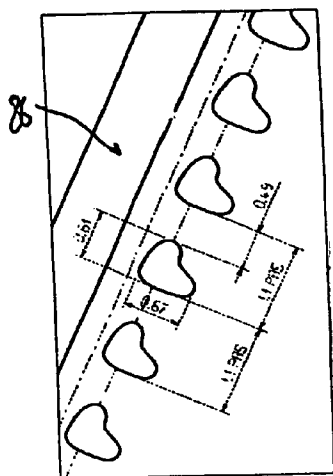
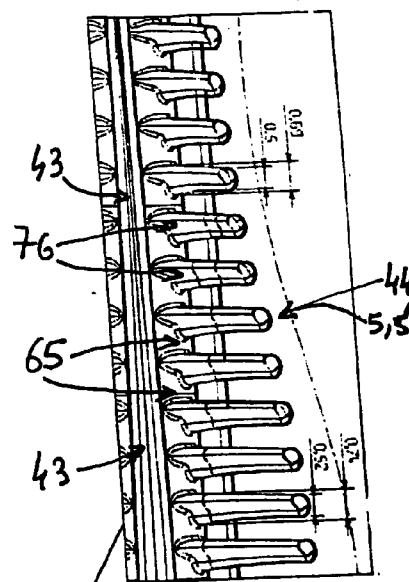
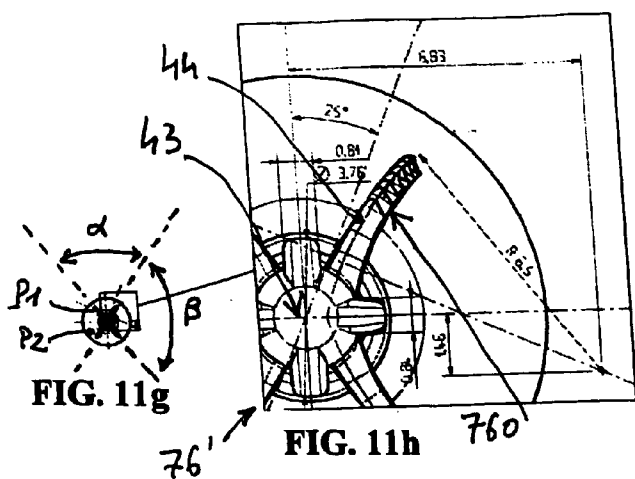

FIG. 11f

FIG. 11d

FIG. 11e

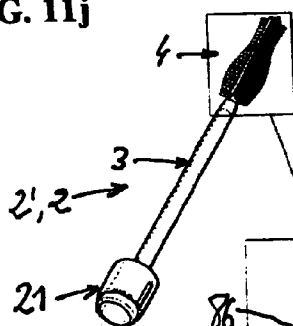

FIG. 11a

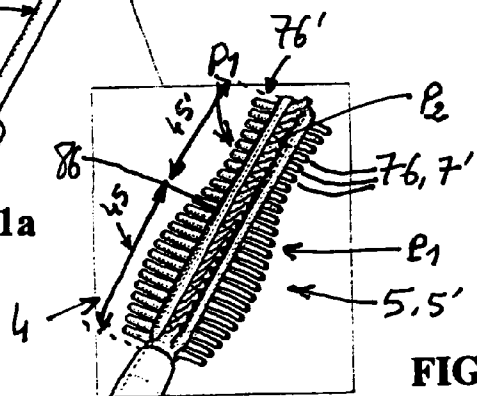

FIG. 11b

**APPLICATOR DEVICE FOR PASTE PRODUCTS,
TYPICALLY COSMETICS**

FIELD OF THE INVENTION

[0001] The invention relates to the domain of fluid or paste product applicator devices, typically cosmetic applicators such as mascaras.

STATE OF THE ART

[0002] Many mascara applicators are already known.

[0003] These applicators are designed to cooperate with a receptacle forming a reservoir for mascara, and typically comprise:

[0004] a) a cap that will close off the said receptacle and act as a gripping means for the said applicator,

[0005] b) an axial rod,

[0006] c) and a brush,

[0007] the said rod being fixed to the said cap at one of its ends, and to the said brush at the other of its ends, the said brush including a twisted metal wire fixing several bristles.

[0008] Very many different brushes are already known.

[0009] Thus, brushes described in French patents FR 2 505 633, FR 2,605,505, FR 2,607,372, FR 2,607,373, FR 2,627,068, FR 2,627,363, FR 2,637,471, FR 2,637,472, FR 2,650,162, FR 2,663,826, FR,2,668,905, FR,2 675,355, FR 2,685,859, FR 2,690,318, FR 2,701,198, FR 2,706,749, FR 2,715,038, FR 2,745,481, FR 2,748,913, FR 2,749,489, FR 2,749,490, FR 2,753,614, FR 2,755,693, FR 2,774,269, FR 2,796,531, FR 2,796,532, FR 2,800,586 are known.

[0010] Brushes described in American patents U.S. Pat. No. 4,733,425, U.S. Pat. No. 4,861,179, U.S. Pat. No. 5,357,987, U.S. Pat. No. 5,595,198, U.S. Pat. No. 6,241,411, U.S. Pat. No. 6,427,700 are also known.

[0011] Problems That Arise

[0012] Firstly, to satisfy continuing changes to mascara formulas, it has been necessary to develop new applicators for application of these formulas, typically adapted to each new formula.

[0013] Secondly, there is also a need for users to have a wide range of applicators to obtain different effects, for example different filling ratios of the product to be applied in the applicator, and/or different eyelash curving effects.

[0014] It is also becoming increasingly necessary to obtain economic and preferably recyclable products, otherwise the corresponding production facilities may be delocalized in countries with low labour costs.

[0015] Finally, in the cosmetics field, there is an ongoing demand for new products, particularly to personalize products in terms of formulas, applicators or even packagings in general, to the extent that renewal of products becomes an absolute commercial necessity, otherwise the market may be lost.

SUMMARY OF THE INVENTION

[0016] According to the invention, the applicator device (1) for a paste product, typically a cosmetic, and typically

intended to cooperate with a receptacle containing the said paste product, contains a longitudinal body with an axial direction, the said longitudinal body including an axial rod and an applicator fixed to the said axial rod, the said rod being intended to cooperate with a manual gripping means of the said applicator device, the said applicator being capable of sampling a fraction of the said product contained in the said receptacle, typically by cooperation of the said applicator with a wiper, so that it can be applied on a support, usually consisting of a part of the body or the face when the said product is a cosmetic, and is characterized in that:

[0017] a) the said applicator forms a single piece plastic part, typically a molded part made of one or several plastic materials,

[0018] b) the said applicator has a shape factor L/D varying from 2 to 7, where L is the axial length and D is the maximum radial diameter of the said applicator or a surrounding volume of the said applicator,

[0019] c) the said axial length L is between 10 and 20 mm,

[0020] d) the said applicator includes a support and a plurality of radial discontinuities fixed to the said support, the said plurality of discontinuities forming a plurality of cavities and/or a plurality of elements in relief, such that the said applicator offers a high contact surface area S with the said product and a high retention volume V of the said product.

[0021] In general, the L/D shape factor will vary from 3 to 6.

[0022] This combination of means provides a means of solving all problems that arise.

[0023] The applicator device according to the invention can be adapted to any type of mascara formulation or any other product sampled by dipping then wiping, particularly by varying the geometry of the said radial discontinuities.

[0024] Compared with a traditional mascara brush, the applicator device according to the invention has the advantage that it includes a single piece applicator formed by a moulded part made of one or several plastic materials which makes high speed automatic production of the said applicators or the said longitudinal bodies possible.

[0025] Thus, it is no longer necessary to assemble a fibre layer with a twisted metal wire, and then to assemble the end of the said twisted metal wire to a rod, itself fixed to a cap.

BRIEF DESCRIPTION OF THE DRAWINGS

[0026] All FIGS. 1a to 11i relate to the invention.

[0027] FIGS. 1a to 1d relate to a first embodiment of the said body (2) of the said applicator device (1).

[0028] FIG. 1a is a perspective side and top view.

[0029] FIG. 1b is a first side view.

[0030] FIG. 1c is another side view at 90° from the first.

[0031] FIG. 1d is a top view.

[0032] FIGS. 2a to 2d, corresponding to FIGS. 1a to 1d respectively, relate to a second embodiment of the said body (2) of the said applicator device (1).

[0033] FIGS. 3a to 3d, corresponding to FIGS. 1a to 1d respectively, relate to a third embodiment of the said body (2) of the said applicator device (1).

[0034] FIGS. 4a to 4d, corresponding to FIGS. 1a to 1d respectively, relate to a fourth embodiment of the said body (2) of the said applicator device (1).

[0035] FIGS. 5a to 5d, corresponding to FIGS. 1a to 1d respectively, relate to a fifth embodiment of the said body (2) of the said applicator device (1).

[0036] FIGS. 6a to 6d, corresponding to FIGS. 1a to 1d respectively, relate to a sixth embodiment of the said body (2) of the said applicator device (1).

[0037] FIGS. 7a to 7d, corresponding to FIGS. 1a to 1d respectively, relate to a seventh embodiment of the said body (2) of the said applicator device (1).

[0038] FIGS. 8a to 8d, corresponding to FIGS. 1a to 1d respectively, relate to an eighth embodiment of the said body (2) of the said applicator device (1).

[0039] FIGS. 9a to 9d, corresponding to FIGS. 1a to 1d respectively, relate to a ninth embodiment of the said body (2) of the said applicator device (1).

[0040] FIGS. 10a to 10b, corresponding to FIGS. 1a to 1d respectively, relate to a tenth embodiment of the said body (2) of the said applicator device (1).

[0041] FIGS. 11a to 11j relate to an eleventh embodiment of the said applicator (2) and the said corresponding applicator device (1).

[0042] FIG. 11a is a perspective view of the said body (2) including the said applicator (4) at one end, and the said head (21) that can be fixed to a cap (9) at the other end.

[0043] FIG. 11b is an enlarged view of the applicator (4) in FIG. 11a.

[0044] FIG. 11c is a first side view of the said body (2) in FIG. 11a.

[0045] FIG. 11d is a second side view at 90° from the view in FIG. 11c.

[0046] FIG. 11e is an axial sectional view of the applicator device (1) according to the invention, the said axial section corresponding to the orientation of the applicator (4) according to FIG. 11c.

[0047] FIG. 11f is an axial section representing an enlarged view of part of the head (21) of the said body (2) and the cap (9) in FIG. 11e.

[0048] FIG. 11g is a top view of the said applicator (4).

[0049] FIG. 11h is an enlarged partial view of the top view in FIG. 11g.

[0050] FIG. 11i is an enlarged partial view of the applicator (4) in FIG. 11d.

[0051] FIG. 11j is an enlarged side view that illustrates the shape of heart-shaped transverse projections (76) and their spacing.

DETAILED DESCRIPTION OF THE INVENTION

[0052] According to the invention, as illustrated in FIGS. 2c, 3c, 4c, 5c, 6c, 7c, 8c, 9c and 10c, the said surrounding volume (40) of the said applicator (4) may be oval and possibly be spindle-shaped, the said applicator (4) having an upper end (41) on the side opposite the said axial rod (3) with a section S_m less than $0.5 S_M$, the said sections S_m and S_M being cross sections in a plane perpendicular to the said axial direction (20), the said section S_M being the maximum section of the said surrounding volume (40), the said section S_M typically being located at mid-height of the said applicator (4) at a distance equal to approximately $0.5 L_A$ from the upper end (41) and the lower end (42) of the said applicator, where L_A is the axial length of the said applicator (4). For example, see FIGS. 3c and 3d on which the sections S_m and S_M are marked.

[0053] As illustrated particularly in FIGS. 1a to 4d, the said plurality of radial discontinuities (5) may include a plurality of elements (7) in relief (7'), typically parallel to each other and at a spacing from each other so as to form intermediate cavities (71), typically annular cavities (71') capable of retaining the said product when the said applicator device (1) is immersed in the said product contained in the said receptacle.

[0054] In this case, the applicator (4) may be considered as being formed of a support (8) to which a plurality of elements (7) is fixed in relief (7').

[0055] However in this case, this same applicator (4) could also be considered as being formed of a support (8') corresponding to the said surrounding volume (40) in which a plurality (6) of cavities (6') are formed.

[0056] As illustrated particularly in FIGS. 1a to 2d, the said plurality of (7) elements in relief (7') may include a number N_t of transverse tabs (70) parallel to each other and perpendicular to the said axial direction, where N_t varies from 5 to 15, and preferably from 7 to 12, so as to form a plurality of transverse cavities (71).

[0057] As illustrated in FIGS. 3a to 3d, the said plurality of elements in relief (7') may comprise a number N_a of axial tabs (72) or quasi-axial tabs oriented along the said axial direction, where N_a varies from 2 to 6 and preferably from 3 to 5, so as to form a plurality of axial cavities (73).

[0058] As illustrated in FIGS. 4a to 4d, the said plurality (7) of elements in relief (7') may form a number $N_t.N_a$ of isolated pads (74) by intersection of the said transverse cavities (71) and axial cavities (73), typically at a right angle.

[0059] As illustrated on part of FIGS. 8a and 8b, the said elements in relief (7') of the said plurality of elements in relief (7'), typically with non-adjacent bases, may be arranged in p columns along the said axial direction and q rows along the said transverse direction perpendicular to the said axial direction, so as to form a number of elements in relief (75) equal to $p.q$, each element in relief typically forming a half-sphere (75').

[0060] According to the invention, the said plurality (5) of radial discontinuities (5') may include the said plurality (6) of cavities (6'), the said support (8) comprising or forming an element of relief between the said cavities (6'), the said

cavities (6') of the said plurality (6) of cavities being capable of retaining the said product when the said applicator device is immersed in the said product contained in the said receptacle.

[0061] The said plurality of cavities (6) may form a plurality of N transverse cavities (60) parallel to each other and perpendicular to the said axial direction (20).

[0062] As already mentioned, the applicators according to FIGS. 1a to 3d may also be considered as belonging to this embodiment.

[0063] As illustrated in FIGS. 5a to 5d, the said transverse cavity (60) is an annular cavity, typically composed of an annular groove (60') formed in the said support (8).

[0064] According to the invention, the said plurality of cavities (6) may form a plurality of n axial cavities (62), typically distributed with a uniform angular spacing, each axial cavity (62) extending over an angle of $360^\circ/n$, the said angle being taken in a transverse plane perpendicular to the said axial direction (20).

[0065] It may be considered that the applicator according to FIGS. 3a to 3d includes a plurality of four axial cavities (62).

[0066] As illustrated on another part of FIGS. 8b and 8c, the said plurality (6) of cavities (6') may form a plurality of typically non-adjacent cavities arranged in p' columns along the said axial direction and q' rows along the said transverse direction perpendicular to the said axial direction, so as to form a number of cavities equal to p'.q', each cavity typically forming a half-sphere (64).

[0067] As illustrated in FIGS. 1a, 3a, 8a to 8d, 9a to 9d, and 10a to 10d, the said support (8) may comprise two faces (80, 80') carrying the said plurality (5) of discontinuities (5'), in which the two faces (80, 80'):

[0068] either both support the said plurality (7) of elements in relief (7'),

[0069] or both support the said plurality (6) of cavities (6'),

[0070] or one face supports the said plurality (6) of cavities (6') and the other face supports the said plurality (7) of elements in relief (7').

[0071] These two faces (80, 80') are generally arranged symmetrically on each side of the said axial direction (20).

[0072] As illustrated in FIGS. 6a to 7d and 9a to 10d, the said support (8) may comprise several distinct support elements in a transverse plane, over at least part of the axial length of the said applicator, the said distinct support elements typically forming a corresponding number of axial branches (81) connected to the said upper end (41) and lower end (42) of the said applicator (4), each axial branch (81) acting as a support for the said plurality (6) of cavities (6') and/or the said plurality (7) of elements in relief (7').

[0073] As illustrated in FIGS. 6a to 7d, the said support (8) may comprise 2 or 3 axial branches (81), each axial branch (81) acting as a support to a number Nt' of transverse tabs (70) parallel to each other and perpendicular to the said axial direction (20), where Nt' varies from 5 to 15 and

preferably from 7 to 12, so as to form a plurality of transverse cavities (71) between the said transverse tabs (70) taken in pairs.

[0074] As illustrated in FIGS. 9a to 9d, the said support (8) may include 2 or 3 axial branches (80) possibly but not necessarily located in the same plane, that define at least one axial space (82) between the said axial branches (81), the said axial space (82) being separated by a plurality of elements fixed to the said axial branches (81).

[0075] In this case, the said plurality of elements may be formed by an axial sequence of elements in relief (7'), typically spheres (77), the said spheres (77) typically adjacent and having a variable diameter in the case in which the said applicator forms a spindle.

[0076] As illustrated in FIGS. 10a to 10d, the said branches (81) may form strips (83) or a strip folded on itself (83'), delimiting an inner space (84), the said strips (83) or the said folded strip (83') acting as a support for the said plurality (5) of radial discontinuities (5') or the said plurality (6) of cavities (6') and/or the said plurality (7) of elements in relief (7').

[0077] The said strip (83, 83') may act as a support for a plurality of elements in relief (830) and for the cavities (831), the said cavities (831) opening up on the said inner space (84).

[0078] The said applicator (4) may comprise a central axial arm (85) designed to partially fill the said axial space (82) so as to limit the quantity of the said product that cannot be transferred onto the said support during the said application.

[0079] As illustrated in FIGS. 11a to 11j, the said plurality (5) of radial discontinuities (5') may form a plurality (7) of N elements in relief (7') fixed to an axial rod portion (86) forming the said support for the said plurality of elements in relief, where N varies from 5 to 30, and typically from 10 to 25.

[0080] The said plurality (7) of elements in relief (7') may be formed by at least a plurality of transverse projections (76), typically arranged symmetrically on each side of the said axial rod portion (86) and aligned along the same axial plane containing the said axial direction (20), the said transverse projections (76) forming a plurality of transverse recesses (65) combining to form the said contact surface S with the said product and the said retention volume V of the said product, each transverse recess (65) being formed by a spacing between two adjacent projections (76).

[0081] As illustrated particularly in FIG. 11g, the said plurality (7) of elements in relief (7') may be formed by two pluralities P1 and P2 of transverse projections (76), the said transverse projections (76) of each plurality P1 and P2 typically being arranged symmetrically on each side of the said axial rod portion (86) and aligned along the same axial plane containing the said axial direction (20), the said pluralities P1 and P2 forming an acute angle α typically less than 70° , and possibly a complementary acute angle β typically greater than 110° , such that the said adjacent portions forming the said acute angle α between them form a dihedral retaining the said product, such that the said adjacent projections forming the said complementary acute angle β between them form a comb for eye lashes during the said application.

[0082] The said pluralities P1 and P2 may form a plurality of four concurrent projections or "X"-shaped teeth in a plane perpendicular to the said axial direction (20), two successive teeth of a said plurality having a transverse recess (65) contributing to forming the said contact surface S with the said product and the said retention volume V of the said product, two concurrent teeth forming the said angle α between them thus also contributing to forming the said contact surface S with the said product and the said retention volume V of the said product.

[0083] As shown in FIG. 11b, the said applicator (1) may comprise a sequence of at least two axial zones (45, 45'), the said adjacent axial zones having a variation of the transverse length of the said transverse projections (76) and/or a variation of the said spacing.

[0084] According to the invention, the said single piece part (4') made of a plastic material forming the said applicator (4) may be a molded part made of only one plastic material.

[0085] However, the said single piece plastic part (4') forming the said applicator (4) may be a molded part made of two plastic materials, the said single piece part (4') comprising a core (43) acting as a support, made of first plastic material and a peripheral part (44) forming the said pluralities (5) of radial discontinuities (5').

[0086] As illustrated on all the figures, the said axial rod (3) and the said applicator (4) form a longitudinal body (2') made of a molded single piece part (2') formed of only one or several plastic materials.

[0087] As illustrated in FIG. 11e, the said manual gripping means is a cap (9) with a skirt threaded on the inside (90) capable of cooperating with a neck of the said receptacle by screwing, the said product typically being a mascara, and the said receptacle typically being a mascara flask, the said longitudinal body (2) comprising a head (21), the said head (21) typically forming a single piece molded part (2'') with the said longitudinal body as illustrated in FIG. 11a.

[0088] Typically, the axial length of the said axial rod (3) may vary from 20 mm to 70 mm so as to cooperate directly or indirectly with the said cap by means of the said head (21).

[0089] According to one variant of the invention, the said axial rod (3) may include a rigid part and a flexible part, the said flexible part typically having a section at least half the size of the said rigid part, so that the said axial rod (3) bends during the said application.

EXAMPLES

[0090] All figures form example embodiments.

[0091] The eleven different embodiments were molded, each embodiment corresponding to one of plates 1 to 11 in the figures.

[0092] Firstly, a single piece parts (2'') were molded forming the said longitudinal bodies made of a single plastic material. The tests were carried out using PP and POM.

[0093] Single piece parts (2'') in which the central part forming the support (8) was made of modified PP were also fabricated, with the said plurality (7) of elements in relief (7') being made of an elastomer.

[0094] Some single piece parts (2'') made entirely of elastomer were also made.

[0095] The applicator devices (1), after dipping in a cosmetic formula, could be used for application on the body (eye lashes, lips or any other part of the body depending on the product considered).

[0096] Bodies (2) were made with axial rods (3) with a cylindrical, oval, square or twisted section, and applicators (4) with a length L varying from 14 mm to 26 mm and a width or largest transverse dimension D varying from 3 mm to 6 mm.

[0097] Results Obtained

[0098] The applicators (4) and applicator devices (1) according to the invention offer a very wide variety of embodiments such that they can be adapted to different types of supports, eye lashes being the support for mascara formulas, and to different types of formulas in which the viscosity and concentration of the solid product can vary, and that can be adapted to achieve the required effect (increased volume, curving or increasing the length of eye lashes in the case of mascara), and several effects can be obtained with applicators according to the invention, and particularly with applicators according to FIGS. 11a to 11j.

[0099] List of Elements

[0100] Applicator device=2+9 . . . 1

[0101] Longitudinal body=3+4 . . . 2

[0102] Single piece part . . . 2'

[0103] Single piece part=3+4+21 . . . 2''

[0104] Axial direction . . . 20

[0105] Head . . . 21

[0106] Axial rod of 2 . . . 3

[0107] Applicator of 2=8+(5, 6, 7) . . . 4

[0108] Single piece part . . . 4'

[0109] Surrounding volume . . . 40

[0110] Upper end . . . 41

[0111] Lower end . . . 42

[0112] Core . . . 43

[0113] Peripheral part . . . 44

[0114] Distinct axial areas . . . 45, 45'

[0115] Plurality of radial discontinuities . . . 5

[0116] Radial discontinuities . . . 5'

[0117] Plurality of cavities . . . 6

[0118] Cavity of 6 . . . 6'

[0119] Transverse cavity . . . 60

[0120] Annular groove . . . 60'

[0121] Transverse relief element . . . 61

[0122] Axial cavity . . . 62

[0123] Axial relief element . . . 63

- [0124] Half-sphere cavity . . . 64
- [0125] Transverse recess . . . 65
- [0126] Several elements in relief . . . 7
- [0127] Elements in relief of 7 . . . 7'
- [0128] Transverse tab . . . 70
- [0129] Transverse cavity . . . 71
- [0130] Annular cavity . . . 71'
- [0131] Axial tab . . . 72
- [0132] Axial cavity . . . 73
- [0133] Pad isolated by intersection of 71 & 73 . . . 74
- [0134] Element in relief . . . 75
- [0135] Element in relief in half-sphere . . . 75'
- [0136] Transverse projection . . . 76
- [0137] Fork . . . 76'
- [0138] Fork tooth . . . 760
- [0139] Adjacent spheres . . . 77
- [0140] Support of 5, 6, 7 . . . 8
- [0141] Faces of 8 . . . 80, 80'
- [0142] Axial branches of 8 . . . 81
- [0143] Axial spacing between branches 81 . . . 82
- [0144] Strip . . . 83
- [0145] Strip folded on itself=loop . . . 83'
- [0146] Elements in relief . . . 830
- [0147] Cavities . . . 831
- [0148] Inner space . . . 84
- [0149] Central axial arm . . . 85
- [0150] Portion of axial rod . . . 86
- [0151] Cap of 1 . . . 9
- [0152] Inner thread . . . 90

what is claimed is:

1. Applicator device (1) for a paste product, typically a cosmetic, typically intended to cooperate with a receptacle containing the said paste product, containing a longitudinal body (2) with an axial direction (20), the said longitudinal body (2) including an axial rod (3) and an applicator (4) fixed to the said axial rod (3), the said axial rod (3) being intended to cooperate with a manual gripping means of the said applicator device (1), the said applicator (4) being capable of sampling a fraction of the said product contained in the said receptacle, typically by cooperation of the said applicator (4) with a wiper, so that it can be applied on a support, usually consisting of a part of the body or the face when the said product is a cosmetic, characterized in that:

- a) the said applicator (4) forms a single piece plastic part (4'), typically a molded part made of one or several plastic materials,
- b) the said applicator (4) has a shape factor L/D varying from 2 to 7, where L is the axial length and D is the

maximum radial diameter of the said applicator (4) or a surrounding volume (40) of the said applicator (4),

- c) the said axial length L is between 10 and 20 mm,
- d) the said applicator (4) includes a support (8) and a plurality (5) of radial discontinuities (5') fixed to the said support (8), the said plurality of radial discontinuities (5) forming a plurality (6) of cavities and/or a plurality (7) of elements in relief (7'), such that the said applicator (1) offers a high contact surface area S with the said product and a high retention volume V of the said product,
- e) and in that the said single piece plastic part (4') forming the said applicator (4) is a moulded part made of one plastic material.

2. Device according to claim 1 in which the said surrounding volume (40) of the said applicator (4) is oval and possibly is spindle-shaped, the said applicator (4) having an upper end (41) on the side opposite the said axial rod (3) with a section S_m less than $0.5 S_M$, the said sections S_m and S_M being cross sections in a plane perpendicular to the said axial direction (20), the said section S_M being the maximum section of the said surrounding volume (40), the said section S_M typically being located at mid-height of the said applicator (4) at a distance equal to approximately $0.5 L_A$ from the upper end (41) and the lower end (42) of the said applicator, where L_A is the axial length of the said applicator (4).

3. Device according to claim 1 in which the said plurality of radial discontinuities (5) includes a plurality of elements (7) in relief (7'), typically parallel to each other and at a spacing from each other so as to form intermediate cavities, typically annular cavities (71') capable of retaining the said product when the said applicator device (1) is immersed in the said product contained in the said receptacle.

4. Device according to claim 3 in which the said plurality (7) of (7') elements in relief (7') includes a number Nt of transverse tabs (70) parallel to each other and perpendicular to the said axial direction, where Nt varies from 5 to 15, and preferably from 7 to 12, so as to form a plurality of transverse cavities (71).

5. Device according to claim 3 in which the said plurality (7) of elements in relief (7') comprises a number Na of axial tabs (72) or quasi-axial tabs oriented along the said axial direction, where Na varies from 2 to 6 and preferably from 3 to 5, so as to form a plurality of axial cavities (73).

6. Device according to claim 4 in which the said plurality (7) of elements in relief (7') forms a number Nt.Na of isolated pads (74) by intersection of the said transverse cavities (71) and axial cavities (73), typically at a right angle.

7. Device according to claim 3 in which the said elements in relief (7') of the said plurality of elements in relief (7'), typically with non-adjacent bases, are arranged in p columns along the said axial direction and q rows along the said transverse direction perpendicular to the said axial direction, so as to form a number of elements in relief (75) equal to p.q, each element in relief typically forming a half-sphere (75').

8. Device according to claim 1 in which the said plurality (5) of radial discontinuities (5') includes the said plurality (6) of cavities (6), the said support (8) comprising or forming an element of relief between the said cavities (6), the said cavities (6) of the said plurality (6) of cavities being capable

of retaining the said product when the said applicator device is immersed in the said product contained in the said receptacle.

9. Device according to claim 8 in which the said plurality (6) of cavities (6') forms a plurality of N transverse cavities (60) parallel to each other and perpendicular to the said axial direction (20).

10. Device according to claim 9 in which the said transverse cavity (60) is an annular cavity, typically composed of an annular groove (60') formed in the said support (8).

11. Device according to claim 8 in which the said plurality (6) of cavities (6') forms a plurality of n axial cavities (62), typically distributed with a uniform angular spacing, each axial cavity (62) extending over an angle of $360^\circ/n$, the said angle being taken in a transverse plane perpendicular to the said axial direction (20).

12. Device according to claim 8 in which the said plurality (6) of cavities (6') forms a plurality of typically non-adjacent cavities arranged in p' columns along the said axial direction and q' rows along the transverse direction perpendicular to the said axial direction, so as to form a number of cavities equal to p'.q', each cavity typically forming a half-sphere (64).

13. Device according to claim 1 in which the said support (8) comprises two faces (80, 80') carrying the said plurality (5) of discontinuities (5'), in which the two faces (80, 80'):

either both support the said plurality (7) of elements in relief (7'),

or both support the said plurality (6) of cavities (6'),

or one face supports the said plurality (6) of cavities (6') and the other face supports the said plurality (7) of elements in relief (7').

14. Device according to claim 1 in which the said support (8) comprises several distinct support elements in a transverse plane, over at least part of the axial length of the said applicator, the said distinct support elements typically forming a corresponding number of axial branches (81) connected to the said upper end (41) and lower end (42) of the said applicator (4), each axial branch (81) acting as a support for the said plurality (6) of cavities (6') and/or the said plurality (7) of elements in relief (7').

15. Device according to claim 14 in which the said support (8) comprises 2 or 3 axial branches (81), each axial branch (81) acting as a support to a number Nt' of transverse tabs (70) parallel to each other and perpendicular to the said axial direction (20), where Nt' varies from 5 to 15 and preferably from 7 to 12, so as to form a plurality of transverse cavities (71) between the said transverse tabs (70) taken in pairs.

16. Device according to claim 14 in which the said support (8) includes 2 or 3 axial branches (80) possibly but not necessarily located in the same plane, that define at least one axial space (82) between the said axial branches (81), the said axial space (82) being separated by a plurality of elements fixed to the said axial branches (81).

17. Device according to claim 16 in which the said plurality of elements is formed by an axial sequence of elements in relief (7'), typically spheres (77), the said spheres (77) typically adjacent and having a variable diameter in the case in which the said applicator forms a spindle.

18. Device according to claim 14 in which the said branches (81) form strips (83) or a strip folded on itself (83'), delimiting an inner space (84), the said strips (83) or the said

folded strip (83') acting as a support for the said plurality (5) of radial discontinuities (5') or the said plurality (6) of cavities (6') and/or the said plurality (7) of elements in relief (7').

19. Device according to claim 18 in which the said strip (83, 83') acts as a support for a plurality of elements in relief (830) and for the cavities (831), the said cavities (831) opening up on the said inner space (84).

20. Device according to claim 16 in which the said applicator (4) comprises a central axial arm (85) designed to partially fill the said axial space (82) so as to limit the quantity of the said product that cannot be transferred onto the said support during the said application.

21. Device according to claim 1 in which the said plurality (5) of radial discontinuities (5') forms a plurality (7) of N elements in relief (7') fixed to an axial rod portion (86) forming the said support for the said plurality of elements in relief, where N varies from 5 to 30, and typically from 10 to 25.

22. Device according to claim 21 in which the said plurality (7) of elements in relief (7') is formed by at least a plurality of transverse projections (76), typically arranged symmetrically on each side of the said axial rod portion (86) and aligned along the same axial plane containing the said axial direction (20), the said transverse projections (76) forming a plurality of transverse recesses (65) combining to form the said contact surface S with the said product and the said retention volume V of the said product, each transverse recess (65) being formed by a spacing between two adjacent projections (76).

23. Device according to claim 22 in which the said plurality (7) of elements in relief (7') is formed by two pluralities P1 and P2 of transverse projections (76), the said transverse projections (76) of each plurality P1 and P2 typically being arranged symmetrically on each side of the said axial rod portion (86) and aligned along the same axial plane containing the said axial direction (20), the said pluralities P1 and P2 forming an acute angle α typically less than 70° , and possibly a complementary acute angle β typically greater than 110° , such that the said adjacent portions forming the said acute angle α between them form a dihedron retaining the said product, such that the said adjacent projections forming the said complementary acute angle β between them form a comb for eye lashes during the said application.

24. Device according to claim 23 in which the said pluralities P1 and P2 form a plurality of four concurrent projections or "X"-shaped teeth in a plane perpendicular to the said axial direction (20), two successive teeth of a said plurality having a transverse recess (65) contributing to forming the said contact surface S with the said product and the said retention volume V of the said product, two concurrent teeth forming the said angle α between them thus also contributing to forming the said contact surface S with the said product and the said retention volume V of the said product.

25. Device according to claim 22 in which the said applicator (1) comprises a sequence of at least two axial zones (45, 45'), the said adjacent axial zones having a variation of the transverse length of the said transverse projections (76) and/or a variation of the said spacing.

26. Device according to claim 1 in which the said axial rod (3) and the said applicator (4) form a longitudinal body

(2') made of a moulded single piece part (2') formed of only one or several plastic materials.

27. Device according to claim 1 in which the said manual gripping means is a cap (9) with a skirt threaded on the inside capable of cooperating with a neck of the said receptacle by screwing, the said product typically being a mascara, and the said receptacle typically being a mascara flask, the said longitudinal body (2) comprising a head (21), the said head (21) typically forming a single piece molded part (2") with the said longitudinal body.

28. Device according to claim 27 in which the axial length of the said axial rod (3) varies from 20 mm to 70 mm so as to cooperate directly or indirectly with the said cap by means of the said head (21).

29. Device according to claim 1 in which the said axial rod (3) includes a rigid part and a flexible part, the said flexible part typically having a section at least half the size of the said rigid part, so that the said axial rod (3) bends during the said application.

* * * * *