

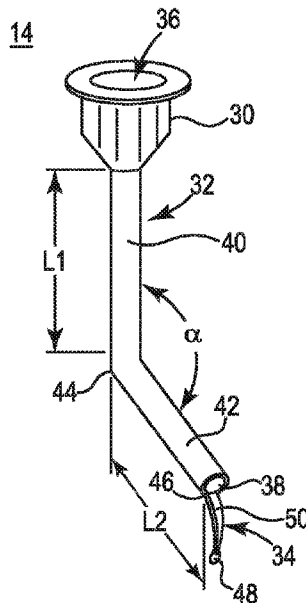

(86) **Date de dépôt PCT/PCT Filing Date:** 2015/10/07
 (87) **Date publication PCT/PCT Publication Date:** 2016/04/14
 (45) **Date de délivrance/Issue Date:** 2023/03/07
 (85) **Entrée phase nationale/National Entry:** 2017/04/07
 (86) **N° demande PCT/PCT Application No.:** US 2015/054513
 (87) **N° publication PCT/PCT Publication No.:** 2016/057681
 (30) **Priorité/Priority:** 2014/10/07 (US14/508,150)

(51) **Cl.Int./Int.Cl. A61M 5/32** (2006.01),
A61F 9/007 (2006.01), **A61M 5/31** (2006.01),
A61M 5/34 (2006.01)
 (72) **Inventeur/Inventor:**
 NOVAK, ANTHONY, US
 (73) **Propriétaire/Owner:**
 NOVAK, ANTHONY, US
 (74) **Agent:** SMART & BIGGAR LP

(54) **Titre : OUTIL D'ADMINISTRATION D'UN ENSEMBLE DE SERINGUE VISCOELASTIQUE**
 (54) **Title: DELIVERY TOOL OF A VISCOELASTIC SYRINGE ASSEMBLY**



(57) **Abstrégé/Abstract:**

A delivery tool connectable with a syringe can be used to deliver a viscoelastic solution. The tool includes a first segment, a second segment and an inner lumen defined by the first and second segments. A distal portion extends from the second segment in a curved manner.

(12) INTERNATIONAL APPLICATION PUBLISHED UNDER THE PATENT COOPERATION TREATY (PCT)

(19) World Intellectual Property
Organization
International Bureau(10) International Publication Number
WO 2016/057681 A1(43) International Publication Date
14 April 2016 (14.04.2016)

- (51) International Patent Classification:
A61M 5/00 (2006.01) *A61M 5/31* (2006.01)
A61M 5/315 (2006.01) *A61M 25/00* (2006.01)
- (21) International Application Number: PCT/US2015/054513
- (22) International Filing Date: 7 October 2015 (07.10.2015)
- (25) Filing Language: English
- (26) Publication Language: English
- (30) Priority Data: 14/508,150 7 October 2014 (07.10.2014) US
- (71) Applicant: **N&M SURGICAL ADVANCEMENTS, LLC** [US/US]; 3046 Bryant Avenue South, Minneapolis, MN 55408 (US).
- (72) Inventor: **NOVAK, Anthony**; 7821 Demontreville Trail North, Lake Elmo, MN 55042 (US).
- (74) Agents: **BONDI, Michael** et al.; Dicke, Billig & Czaja, PLLC, 100 South Fifth Street, Suite 2500, Minneapolis, MN 55402 (US).
- (81) Designated States (*unless otherwise indicated, for every kind of national protection available*): AE, AG, AL, AM, AO, AT, AU, AZ, BA, BB, BG, BH, BN, BR, BW, BY, BZ, CA, CH, CL, CN, CO, CR, CU, CZ, DE, DK, DM, DO, DZ, EC, EE, EG, ES, FI, GB, GD, GE, GH, GM, GT, HN, HR, HU, ID, IL, IN, IR, IS, JP, KE, KG, KN, KP, KR, KZ, LA, LC, LK, LR, LS, LU, LY, MA, MD, ME, MG,

[Continued on next page]

(54) Title: DELIVERY TOOL OF A VISCOELASTIC SYRINGE ASSEMBLY

(57) Abstract: A delivery tool connectable with a syringe can be used to deliver a viscoelastic solution. The tool includes a first segment, a second segment and an inner lumen defined by the first and second segments. A distal portion extends from the second segment in a curved manner.

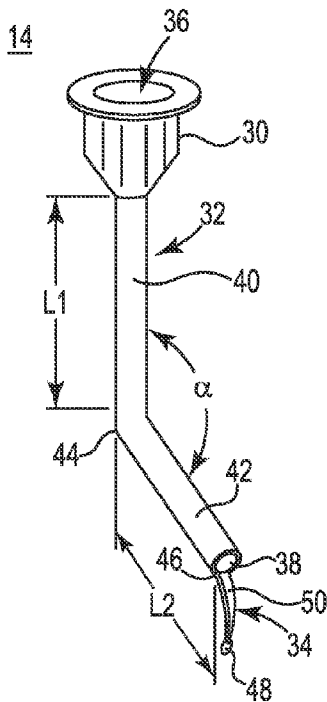
**Fig. 2**

WO 2016/057681 A1

WO 2016/057681 A1 

MK, MN, MW, MX, MY, MZ, NA, NG, NI, NO, NZ, OM, PA, PE, PG, PH, PL, PT, QA, RO, RS, RU, RW, SA, SC, SD, SE, SG, SK, SL, SM, ST, SV, SY, TH, TJ, TM, TN, TR, TT, TZ, UA, UG, US, UZ, VC, VN, ZA, ZM, ZW.

SI, SK, SM, TR), OAPI (BF, BJ, CF, CG, CI, CM, GA, GN, GQ, GW, KM, ML, MR, NE, SN, TD, TG).

Declarations under Rule 4.17:

- *as to the identity of the inventor (Rule 4.17(i))*
- *as to applicant's entitlement to apply for and be granted a patent (Rule 4.17(ii))*

Published:

- *with international search report (Art. 21(3))*

- (84) Designated States** (*unless otherwise indicated, for every kind of regional protection available*): ARIPO (BW, GH, GM, KE, LR, LS, MW, MZ, NA, RW, SD, SL, ST, SZ, TZ, UG, ZM, ZW), Eurasian (AM, AZ, BY, KG, KZ, RU, TJ, TM), European (AL, AT, BE, BG, CH, CY, CZ, DE, DK, EE, ES, FI, FR, GB, GR, HR, HU, IE, IS, IT, LT, LU, LV, MC, MK, MT, NL, NO, PL, PT, RO, RS, SE,

DELIVERY TOOL OF A VISCOELASTIC SYRINGE ASSEMBLY

Background

- [1] Cataract surgeries generally involve one or more tools to provide an incision in the cornea and ultimately remove a cataract. After the incision, in current surgical techniques, a viscoelastic solution is delivered into an anterior chamber defined by the cornea such that the cornea is protected during removal of the cataract and, if utilized, placement of an intraocular lens implant. In one current surgical technique, called phacoemulsification, an ultrasonic probe is inserted through the incision. The probe then vibrates, causing emulsification of the cataract. The cataract is then aspirated from the eye along with the injected viscoelastic solution. Due to care and precision required to perform cataract surgeries, approaches to improving surgical techniques for removal of cataracts is desired.

Summary

- [2] A delivery tool connectable to a syringe can be used to deliver a viscoelastic solution. The tool includes a first segment, a second segment and an inner lumen defined by the first and second segments. A distal portion extends from the second segment in a curved manner.
- [2a] Some embodiments disclosed herein provide a delivery tool connectable to a syringe, comprising: a first segment extending along a first axis; a second segment connected to the first segment at a bend portion and extending along a second axis that is oriented at a first angle with respect to the first axis, wherein the second segment has a distal opening; an inner lumen extending between the first segment and the distal opening; and a tip portion including a surface extending from and fixed to a portion of the second segment that forms the distal opening, wherein opposite the second segment, the tip portion has a distal tip having a substantially bulbous shape that originates at a distal end of the surface such that the bulbous shape is separated from the distal opening by the surface, wherein the surface tapers from the distal opening to the distal tip and wherein the surface curves away from the second axis and wherein the second segment is linear and the distal opening is located in a plane perpendicular to the second axis.
- [2b] Some embodiments disclosed herein provide a syringe assembly, comprising: a delivery tool comprising: a first segment extending along a first axis and having a

hub; a second segment connected to the first segment at a bend portion that is opposite the hub and extending along a second axis that is oriented at a first angle with respect to the first axis, wherein the second segment has a distal opening and wherein the first segment and the second segment define an inner lumen extending from the hub to the distal opening; and a tip portion including a surface extending from and fixed to a portion of the second segment that forms the distal opening, the surface extending from the distal opening, wherein opposite the second segment, the tip portion has a distal tip having a substantially bulbous shape that originates at a distal end of the surface such that the substantially bulbous shape is separated from the distal opening by the surface; and wherein the surface curves away from the second axis; and wherein the second segment is linear and the distal opening is located in a plane perpendicular to the second axis a syringe connected to the hub of the delivery tool so that an axis of the syringe is aligned with the first axis, the syringe including a plunger and rod such that, upon actuation of the rod, fluid is delivered to the lumen of the delivery tool.

[2c] Some embodiments disclosed herein provide a delivery tool connectable to a syringe, the delivery tool comprising: a cannula having an inner lumen that terminates at a distal opening; and a tip portion including a surface extending from and fixed to a portion of the cannula that forms the distal opening, the surface having two opposing edges, each of the two opposing edges being fixed to the portion of the cannula that forms the distal opening at spaced apart locations along a circumference of the distal opening, wherein opposite the cannula, the tip portion has a distal tip having a substantially bulbous shape fixed to the surface that originates at a distal end of the surface such that the substantially bulbous shape is separated from the distal opening by the surface, the bulbous shape interconnecting the two opposing edges, wherein a width of the surface between the two opposing edges tapers from the distal opening to the distal tip; further wherein the substantially bulbous shape has a width that is less than an outer diameter of the cannula.

[2d] Some embodiments disclosed herein provide an assembly, comprising: a delivery tool comprising: a cannula having a hub and an inner lumen that terminates at a distal opening; and a tip portion including a surface extending from and fixed to a portion of the cannula that forms the distal opening, wherein opposite the cannula, the tip portion has a distal tip having a substantially bulbous shape fixed to the surface

that originates at a distal end of the surface such that the substantially bulbous shape is separated from the distal opening by the surface, wherein the surface tapers from the distal opening to the distal tip; a width of the surface tapers from the distal opening to the distal tip; further wherein the substantially bulbous shape has a width that is less than an outer diameter of the cannula; and a syringe connected to the hub of the delivery tool.

[2e] Some embodiments disclosed herein provide a delivery tool connectable to a syringe, the delivery tool comprising: a cannula having an inner lumen that terminates at a distal opening; and a tip portion including a curve defined as a central axis of the tip portion, the tip portion including a surface extending from and fixed to a portion of the cannula that forms the distal opening, wherein opposite the cannula, the tip portion has a distal tip having a substantially bulbous tip fixed to the surface that originates at a distal end of the surface such that the substantially bulbous tip is separated from the distal opening by the surface, wherein, the surface includes a bevel and, relative to the curve, the bevel is positioned to one side of the tip portion.

[2f] Some embodiments disclosed herein provide a syringe assembly, comprising: a delivery tool including: a cannula having an inner lumen that terminates at a distal opening; and a tip portion including a curve defined as a central axis of tip portion, the tip portion including a surface extending from and fixed to a portion of the cannula that forms the distal opening, wherein opposite the cannula, the tip portion has a distal tip having a substantially bulbous tip fixed to the surface that originates at a distal end of the surface such that the substantially bulbous tip is separated from the distal opening by the surface, wherein, the surface includes a bevel and, relative to the curve, the bevel is positioned to one side of the tip portion; and a syringe connected to the delivery tool.

Brief Description of the Drawings

- [3]** Figure 1 is a side view of a viscoelastic syringe assembly.
- [4]** Figure 2 is an isometric view of a delivery tool connectable to a syringe.
- [5]** Figure 3A is a side view of the delivery tool of Figure 2.
- [6]** Figure 3B is a cross sectional view of a portion of the delivery tool of Figure 2.
- [7]** Figure 4 is a front view of an alternative delivery tool connectable to a syringe.
- [8]** Figure 5 is a front view of an alternative delivery tool connectable to a syringe.

Detailed Description

[9] In the following detailed description, reference is made to the accompanying drawings which form a part hereof, and in which is shown by way of illustration specific

examples in which the disclosure may be practiced. It is to be understood that other examples may be utilized and structural or logical changes may be made without departing from the scope of the present disclosure. It is to be understood that features of the various examples described herein may be combined, in part or whole, with each other, unless specifically noted otherwise.

[10] While the disclosure refers to illustrative embodiments for particular applications, it should be understood that the disclosure is not limited thereto. Modifications can be made to the embodiments described herein without departing from the spirit and scope of the present disclosure. Those skilled in the art with access to this disclosure will recognize additional modifications, applications, and embodiments within the scope of this disclosure and additional fields in which the disclosed examples could be applied. Therefore, the following detailed description is not meant to be limiting. Further, it is understood that the systems and methods described below can be implemented in many different embodiments. The operation and behavior of the systems and methods presented are described with the understanding that modifications and variations of the embodiments are possible given the level of detail presented.

[11] References to “one embodiment,” “an embodiment,” “in certain embodiments,” etc., indicate that the embodiment described may include a particular feature, structure, or characteristic, but every embodiment may not necessarily include the particular feature, structure, or characteristic. Moreover, such phrases are not necessarily referring to the same embodiment. Further, when a particular feature, structure, or characteristic is described in connection with an embodiment, it is submitted that it is within the knowledge of one skilled in the art to affect such feature, structure, or characteristic in connection with other embodiments whether or not explicitly described.

[12] Figure 1 is a side view of an exemplary syringe assembly 10 that includes a syringe 12 and a delivery tool 14 fluidly coupled with the syringe 12. Syringe 12 includes a cylindrical body 16, a plunger 18 and a rod 20 coupled with the plunger 18. During use, fluid (e.g., a viscoelastic solution) is positioned within the cylindrical body 16. A user can

operate the rod 20 to move the plunger 18 relative to the cylindrical body 12 along a longitudinal axis A. To provide fluid to the delivery tool 14, the plunger 18 is actuated toward an orifice 22 that is fluidly coupled with the delivery tool 14. From the orifice 22, the fluid enters the delivery tool 14.

[13] As illustrated in Fig. 2, delivery tool 14 includes a hub 30, a cannula 32 and a distal portion 34 extending from the cannula 32. The hub 30 fluidly communicates with the orifice 22 of the syringe 12 to receive fluid therefrom. In one embodiment, the hub 30 includes a luer lock to establish a leak-free connection between the orifice 22 and the cannula 32. Other types of connections can further be utilized. In one embodiment, the cannula 32 and distal portion 34 are integrally formed of a material useful in biomedical applications such as surgical stainless steel. The cannula 32, in one embodiment, defines a diameter of approximately 27 gauge.

[14] As will be discussed in more detail below, the cannula 32 defines an inner lumen 36 that extends from the hub 30 to a distal opening 38. In particular, the lumen extends from the hub 30, along a first, proximal segment 40, a second, distal segment 42 connected with the first segment 40 and to the distal opening 38. The first segment 40 is connected to the second segment 42 with a bend portion 44 such that second segment 42 is offset with respect to the first segment 40. The second segment 42 extends from the bend portion 44 to a connection point 46 with the distal portion 34.

[15] The distal portion 34 extends from the connection point 46 with second segment 42 in a curved manner to a distal tip 48. A beveled surface 50 extends along one side of the distal portion 34. The distal portion 34 can be formed with a generally circular cross section or with other cross section shapes (e.g., rectangular, oval) as desired. In the illustrated embodiment, a width of the distal portion 34 tapers from a width of approximately 2.0 to 1.0 mm at connection point 46 to a width of approximately 1 to 0.25 mm at distal tip 48. Distal tip 48, in one embodiment, includes a blunt, bulbous tip having a diameter of approximately 0.25 to 2.0 mm. The beveled surface 50 can be formed of a flat (or substantially flat) surface. In an alternative embodiment, the beveled surface 50 can be formed of a curved surface.

- [16] Geometric relationship of the first segment 40, second segment 42 and distal portion 34 is discussed below with respect to Figure 3A. The first segment 40 extends longitudinally from the hub 30 along axis A to bend portion 44. Axis A can be referred to as a central axis of first segment 40. In one embodiment, the first segment 40 defines a length L1 from hub 30 to bend portion 44 of approximately 1.0 centimeters to 3.0 cm. In one particular embodiment, the length L1 of first segment 40 is approximately 2.0 cm.
- [17] The second segment 42 extends from the bend portion 44 along a longitudinal axis B to connection point 46. Axis B can be referred to as a central axis of second segment 42. Axis B is positioned at an angle α relative to axis A of first segment 40. In one embodiment, the angle α is approximately in a range from 20 degrees to 90 degrees. In one particular embodiment, the angle α is approximately 45 degrees. The second segment 42 as measured from bend portion 44 to connection point 46, in one embodiment, has a length L2 of approximately 0.5 cm to 1.5 cm. In one particular embodiment, length L2 of second segment 38 is approximately 1.0 cm.
- [18] The distal portion 34 extends from the connection point 46 to the distal tip 48 in a curved manner as defined by a curve 52. Curve 52 can be defined as a central axis of the distal portion 34. At least a part of the curve 52 deviates from the axis B and, in one embodiment, an entirety of the curve 52 deviates from axis B. As shown in the illustrated embodiment, the distal portion 34 is positioned below the opening 38 such that distal portion 34 does not have any part that touches axis B. In a further embodiment, at least the distal tip 48 deviates from axis B.
- [19] Relative to curve 52, beveled surface 50 is positioned to one side of the distal portion 34. As illustrated in Figure 3B, when distal portion 34 is viewed in cross section perpendicular to the curve 52, an arc 54 defined by an outer surface of the distal tip 34 extending to either side of beveled surface 50 can be approximately 50 to 320 degrees.
- [20] In one embodiment, curve 52 of the distal portion 34 can be defined relative to a Cartesian coordinate system wherein axis B serves as a first axis and an axis C serves as a second axis, perpendicular to axis B. In particular, the curve 52 is a plane curve that extends within a plane BC defined by axes B and C. An origin of the coordinate system is located at the connection point 46. Relative to axis C, distal tip 48 extends from

connection point 46 a distance X of approximately 0.3 to 3.5 mm. In one particular embodiment, distance X is approximately 1.5 mm. Additionally, relative to axis B, the distal tip 48 extends from connection point 46 a distance Y (e.g., away from first segment 40) from axis B of approximately 0.5 to 1.5 mm. In one particular embodiment, the distance Y is approximately 1.0 mm from the axis. Moreover, since curve 52 lies in plane BC, a distance Z from plane BC to distal tip 48 is zero.

[21] A line D connecting the connection point 46 and distal tip 48 defines an angle β with respect to axis B that is approximately in a range from 20 to 40 degrees from the axis of the second segment 42. In one particular embodiment, the angle β is approximately 30 degrees. A height H of the curve 52 (as defined from line D to a maximum distance from line D) is in a range of 0.1 to 4.5 mm and a width W of the curve 52 along line D is in a range of 0.5 to 2.0 mm. The curve 52 has a radius of curvature of approximately 4.0 to 10 mm.

[22] In Figure 3A discussed above, curve 52 is a plane curve defined in two dimensions that lies in a plane defined by axes A, B and C. As such, the embodiment of Figure 3A can generally be referred to as a straight configuration, wherein the geometric arrangement among central axis of first segment 40, second segment 42 and distal portion 34 can generally be described in two dimensions. In further embodiments, the distal portion 34 can extend from second segment 42 in a curved manner away from a plane defined by axes B and C. For example, the delivery tool 14 can further include a right-handed curvature or a left-handed curvature (as viewed by an operator holding the assembly 10 during use), illustrated in Figures 4 and 5, respectively. In such embodiments, the curve of the distal portion 34 can be a space curve defined in three dimensions.

[23] In Figure 4 illustrating the right-handed curvature, a distal portion 34' defines a curve 52' extending from connection point 46 to a distal tip 48' in a direction away from plane BC. The curve 52' can extend within plane BC in various ways, for example being coplanar with plane BC or extending in a similar manner to that discussed above with respect to curve 52. While curve 52' will be discussed below relative to a plane including plane BC and extending along an axis E perpendicular to plane BC and including

connection point 46, it will be appreciated that curve 52' is not limited to only being positioned with respect to axes B and E, but also with respect to axis C. Stated another way, distal tip 48' can be positioned in a direction along axis C in any desired position (including along axis B).

[24] With the above understanding in mind, curve 52' of the distal portion 34 can be defined relative to a Cartesian coordinate system wherein axis B serves as a first axis and axis E serves as a second axis, perpendicular to axis B. In particular, the curve 52' extends within a plane BE defined by axes B and E. An origin of the coordinate system is located at the connection point 46. Relative to axis C along axis B, distal tip 48' extends from connection point 46 a distance X' of approximately 0.1 to 2.0 mm. In one particular embodiment, distance X' is approximately 1.0 mm. Relative to axis B along axis C, for example as discussed above with respect to curve 50, the distal tip 48' extends from connection point 46 a distance Y' from axis B of approximately 0.5 to 1.5 mm. In one particular embodiment, the distance Y' is approximately 1.0 mm from the axis. Relative to axis E along axis B, the distal tip 34 extends a distance Z' of approximately 0.1 to 2.5 mm. In one embodiment, distance Z' is approximately 1.0 mm.

[25] A line F connecting the connection point 46 and distal tip 48' defines an angle γ with respect to axis B that is approximately in a range from 20 to 40 degrees from the axis of the second segment 42. In one particular embodiment, the angle γ is approximately 25 degrees. A height H' of the curve 52' (as defined from line F to a maximum distance of curve 52' from line F) is in a range of 0.1 to 1.0 mm and a width W' of the curve 52' along line F is in a range of 0.1 to 1.0 mm. The curve 52' has a radius of curvature of approximately 4.0 to 10.0 mm.

[26] In Figure 5 illustrating the left-handed curvature, a distal portion 34'' defines a curve 52'' extending from connection point 46 to a distal tip 48'' in a direction away from plane BC in an opposite direction from distal portion 34'. The curve 52'' can extend within plane BC in various ways, for example being coplanar with plane BC or extending in a similar manner to that discussed above with respect to curve 52. While curve 52'' will be discussed below relative to a plane including plane BC and extending along an axis E perpendicular to plane BC and including connection point 46, it will be

appreciated that curve 52'' is not limited to only being positioned with respect to axes B and E, but also with respect to axis C. Stated another way, distal tip 48'' can be positioned along axis C in any desired position (including along axis B).

[27] With the above understanding in mind, curve 52'' of the distal portion 34'' can be defined relative to a Cartesian coordinate system wherein axis B serves as a first axis and axis E serves as a second axis, perpendicular to axis B. In particular, the curve 52'' extends within a plane BE defined by axes B and E. An origin of the coordinate system is located at the connection point 46. Relative to axis C along axis B, distal tip 48'' extends from connection point 46 a distance X'' of approximately 0.1 to 2.5 mm. In one particular embodiment, distance X'' is approximately 1.0 mm. Additionally, relative to axis B along axis C, the distal tip 48'' extends from connection point 46 a distance Y'' from axis B of approximately 0.5 to 1.5 mm. In one particular embodiment, the distance Y'' is approximately 1.0 mm from the axis. Relative to axis E along axis B, the distal tip 34 extends a distance Z'' of approximately 0.1 to 2.5 mm. In one embodiment, Z'' is approximately 1.0 mm.

[28] A line G connecting the connection point 46 and distal tip 48'' defines an angle δ with respect to axis B that is approximately in a range from 20 to 40 degrees from the axis of the second segment 42. In one particular embodiment, the angle δ is approximately 25 degrees. A height H'' of the curve 52'' (as defined from line G to a maximum distance of curve 52'' from line G) is in a range of 0.1 to 1.5 mm and a width W'' of the curve 52'' along line G is in a range of 0.1 to 1.5 mm. The curve 52'' has a radius of curvature of approximately 4.0 to 10.5 mm.

[29] Although specific embodiments have been illustrated and described herein, it will be appreciated by those of ordinary skill in the art that a variety of alternate and/or equivalent implementations may be substituted for the specific embodiments shown and described without departing from the scope of the present invention. This application is intended to cover any adaptations or variations of the specific embodiments discussed herein. Therefore, it is intended that this invention be limited only by the claims and the equivalents thereof.

CLAIMS:

1. A delivery tool connectable to a syringe, comprising:
a first segment extending along a first axis;
a second segment connected to the first segment at a bend portion and extending along a second axis that is oriented at a first angle with respect to the first axis, wherein the second segment has a distal opening;
an inner lumen extending between the first segment and the distal opening; and
a tip portion including a surface extending from and fixed to a portion of the second segment that forms the distal opening, wherein opposite the second segment, the tip portion has a distal tip having a substantially bulbous shape that originates at a distal end of the surface such that the bulbous shape is separated from the distal opening by the surface, wherein the surface tapers from the distal opening to the distal tip and wherein the surface curves away from the second axis and wherein the second segment is linear and the distal opening is located in a plane perpendicular to the second axis.
2. The delivery tool of claim 1, wherein the first angle defined between the first axis and the second axis is in a range of 20 to 90 degrees.
3. The delivery tool of claim 2, wherein the first angle is 45 degrees.
4. The delivery tool of claim 1, wherein a connection point is defined as a point in a plane of the circumference of the second segment at the distal opening; wherein a second angle defined by a straight line connecting the connection point and the distal tip relative to the second axis is in a range of 20 to 90 degrees.
5. The delivery tool of claim 4, wherein the second angle is 30 degrees.
6. The delivery tool of claim 4, wherein the second angle is 25 degrees.

7. The delivery tool of claim 1, wherein the distal tip deviates from a plane defined by the first axis and the second axis.
8. The delivery tool of claim 1, wherein the curve is a plane curve.
9. The delivery tool of claim 1, wherein the curve is a space curve.
10. The delivery tool of claim 1, wherein a minimum distance of the distal tip to a plane defined by the first axis and the second axis is 1 mm.
11. The delivery tool of claim 1, wherein the surface continually tapers from the distal opening to the distal tip and includes a beveled surface.
12. The delivery tool of claim 11, wherein the beveled surface is concave.
13. The delivery tool of claim 1, wherein the distal tip is rigid and the substantially bulbous shape has an external surface; wherein the delivery tool is arranged and configured to direct fluid from the first segment, to the second segment, to the surface and then over the external surface of the substantially bulbous shape.
14. The delivery tool of claim 13, wherein the substantially bulbous shape is ovoid.
15. A syringe assembly, comprising:
 - a delivery tool comprising:
 - a first segment extending along a first axis and having a hub;
 - a second segment connected to the first segment at a bend portion that is opposite the hub and extending along a second axis that is oriented at a first angle with respect to the first axis, wherein the second segment has a distal opening and wherein the first segment and the second segment define an inner lumen extending from the hub to the distal opening; and
 - a tip portion including a surface extending from and fixed to a portion of the second segment that forms the distal opening, the surface extending from the distal opening, wherein opposite the second segment, the tip portion

has a distal tip having a substantially bulbous shape that originates at a distal end of the surface such that the substantially bulbous shape is separated from the distal opening by the surface; and wherein the surface curves away from the second axis; and
wherein the second segment is linear and the distal opening is located in a plane perpendicular to the second axis
a syringe connected to the hub of the delivery tool so that an axis of the syringe is aligned with the first axis, the syringe including a plunger and rod such that, upon actuation of the rod, fluid is delivered to the lumen of the delivery tool.

16. The syringe assembly of claim 15, wherein the surface continually tapers from the distal opening to the distal tip.

17. The syringe assembly of claim 15, wherein the delivery tool is arranged and configured to direct fluid from the first segment, to the second segment, to the surface and then over an external surface of the substantially bulbous tip.

18. The syringe assembly of claim 17, wherein the substantially bulbous shape is ovoid.

19. The syringe assembly of claim 15, wherein the surface includes a beveled surface that is rigid and concave.

20. A delivery tool connectable to a syringe, the delivery tool comprising:
a cannula having an inner lumen that terminates at a distal opening; and
a tip portion including a surface extending from and fixed to a portion of the cannula that forms the distal opening, the surface having two opposing edges, each of the two opposing edges being fixed to the portion of the cannula that forms the distal opening at spaced apart locations along a circumference of the distal opening, wherein opposite the cannula, the tip portion has a distal tip having a substantially bulbous shape fixed to the surface that originates at a distal end of the surface such that the substantially bulbous shape is separated from the distal opening by the surface, the bulbous shape interconnecting the two opposing edges, wherein a width of the surface between the two opposing edges tapers from the distal

opening to the distal tip; further wherein the substantially bulbous shape has a width that is less than an outer diameter of the cannula.

21. The delivery tool of claim 20, wherein the surface continually tapers from the distal opening to the distal tip.
22. The delivery tool of claim 20, wherein the surface is beveled.
23. The delivery tool of claim 20, wherein the distal tip is rigid and the substantially bulbous shape has an external surface; wherein the delivery tool is arranged and configured to direct fluid from the cannula, to the surface and then over the external surface of the substantially bulbous shape.
24. The delivery tool of claim 20, wherein the substantially bulbous shape is ovoid.
25. The delivery tool of claim 20, wherein the wherein the tip portion deviates from a central axis of the cannula proximate the distal opening.
26. The delivery tool of claim 20, wherein the tip portion is curved.
27. The delivery tool of claim 20, wherein the distal opening shares a central axis with the cannula.
28. The delivery tool of claim 20, wherein the distal opening has a diameter equal to that of the inner lumen.
29. The delivery tool of claim 20, wherein the inner lumen defines a central axis and the surface is non-intersecting with the central axis.
30. The delivery tool of claim 20, wherein the cannula includes a first segment and a second segment.

31. The delivery tool of claim 30, wherein the second segment has a second central axis; wherein the distal tip deviates from a plane defined by the first central axis and the second central axis.
32. The delivery tool of claim 30, wherein the second segment extends outwardly from a first central axis of the first segment at an angle.
33. The delivery tool of claim 32, wherein the angle is in a range of 20 to 90 degrees.
34. The delivery tool of claim 33, wherein the angle is about 45 degrees.
35. An assembly, comprising:
a delivery tool comprising:
a cannula having a hub and an inner lumen that terminates at a distal opening; and
a tip portion including a surface extending from and fixed to a portion of the cannula that forms the distal opening, wherein opposite the cannula, the tip portion has a distal tip having a substantially bulbous shape fixed to the surface that originates at a distal end of the surface such that the substantially bulbous shape is separated from the distal opening by the surface, wherein the surface tapers from the distal opening to the distal tip; a width of the surface tapers from the distal opening to the distal tip; further wherein the substantially bulbous shape has a width that is less than an outer diameter of the cannula; and
a syringe connected to the hub of the delivery tool.
36. The assembly of claim 35, wherein a central axis of the syringe is aligned with a central axis of the cannula, the syringe including a plunger and rod such that, upon actuation of the rod, fluid is delivered to the inner lumen of the delivery tool.
37. The assembly of claim 35, wherein the inner lumen defines a central axis and the surface is non-intersecting with the central axis.
38. A delivery tool connectable to a syringe, the delivery tool comprising:
a cannula having an inner lumen that terminates at a distal opening; and

a tip portion including a curve defined as a central axis of the tip portion, the tip portion including a surface extending from and fixed to a portion of the cannula that forms the distal opening, wherein opposite the cannula, the tip portion has a distal tip having a substantially bulbous tip fixed to the surface that originates at a distal end of the surface such that the substantially bulbous tip is separated from the distal opening by the surface, wherein, the surface includes a bevel and, relative to the curve, the bevel is positioned to one side of the tip portion.

39. The delivery tool of claim 38, wherein the substantially bulbous tip has a width that is less than an outer diameter of the cannula.
40. The delivery tool of claim 38, wherein the surface tapers from the distal opening to the distal tip.
41. The delivery tool of claim 38, wherein bevel is a planar surface.
42. The delivery tool of claim 38, wherein the bevel is a curved surface.
43. The delivery tool of claim 38, wherein the distal tip is rigid and the substantially bulbous tip has an external surface; wherein the delivery tool is arranged and configured to direct fluid from the cannula, to the surface and then over the external surface of the substantially bulbous tip.
44. The delivery tool of claim 38, wherein the substantially bulbous tip is ovoid.
45. The delivery tool of claim 38, wherein the cannula includes a first segment and a second segment.
46. The delivery tool of claim 45, wherein the second segment extends outwardly from a first central axis of the first segment at an angle.
47. The delivery tool of claim 38, wherein an arc defined by an outer surface of the tip portion extending to either side of the bevel is in a range of 50 to 320 degrees.

48. The delivery tool of claim 38, wherein the bevel is a flat surface.
49. A syringe assembly, comprising:
a delivery tool including:
a cannula having an inner lumen that terminates at a distal opening; and
a tip portion including a curve defined as a central axis of tip portion, the tip portion including a surface extending from and fixed to a portion of the cannula that forms the distal opening, wherein opposite the cannula, the tip portion has a distal tip having a substantially bulbous tip fixed to the surface that originates at a distal end of the surface such that the substantially bulbous tip is separated from the distal opening by the surface, wherein, the surface includes a bevel and, relative to the curve, the bevel is positioned to one side of the tip portion;
and
a syringe connected to the delivery tool.
50. The syringe assembly of claim 49, wherein a central axis of the syringe is aligned with a central axis of the cannula, the syringe including a plunger and rod such that, upon actuation of the rod, fluid is delivered to the inner lumen of the delivery tool.
51. The syringe assembly of claim 49, wherein the substantially bulbous tip has a width that is less than an outer diameter of the cannula.
52. The syringe assembly of claim 49, wherein the surface tapers from the distal opening to the distal tip.
53. The syringe assembly of claim 49, wherein bevel is a planar surface.
54. The syringe assembly of claim 49, wherein the bevel is a curved surface.
55. The syringe assembly of claim 49, wherein an arc defined by an outer surface of the tip portion extending to either side of the bevel is in the range of 50 to 320 degrees.
56. The syringe assembly of claim 49, wherein the bevel is a flat surface.

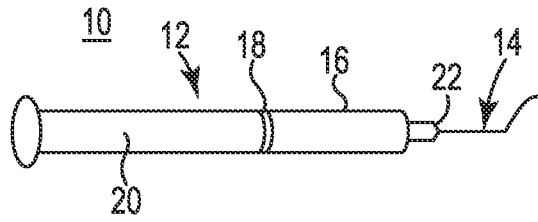

Fig. 1

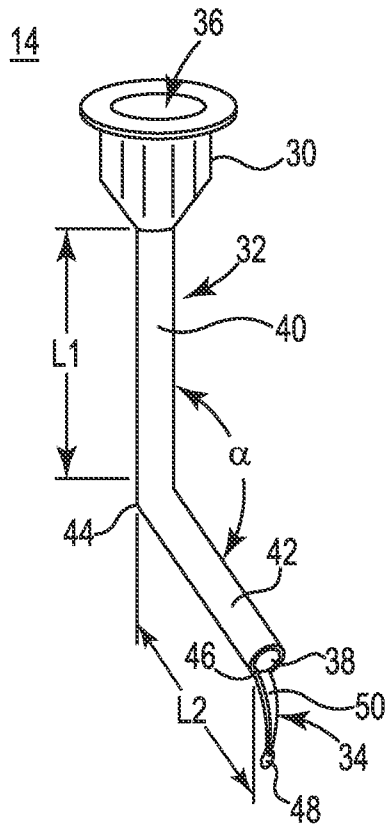

Fig. 2

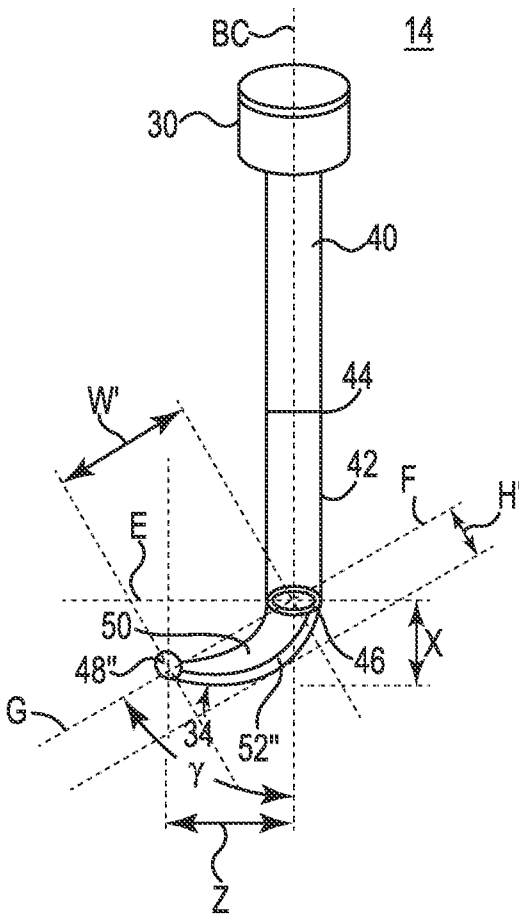

Fig. 4

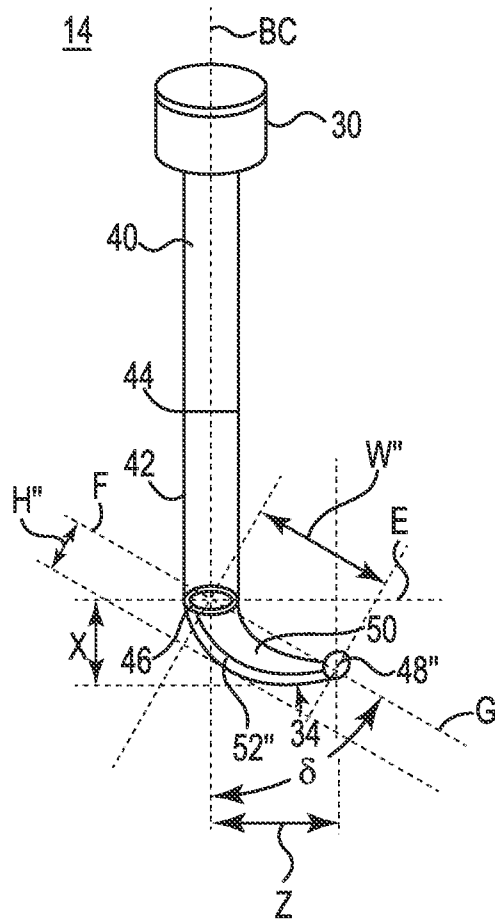

Fig. 5

14

