

No. 728,148.

PATENTED MAY 12, 1903.

F. M. WEVER.
ACID OR OTHER LIQUID DISTRIBUTING SYSTEM.

APPLICATION FILED OCT. 18, 1902.

NO MODEL.

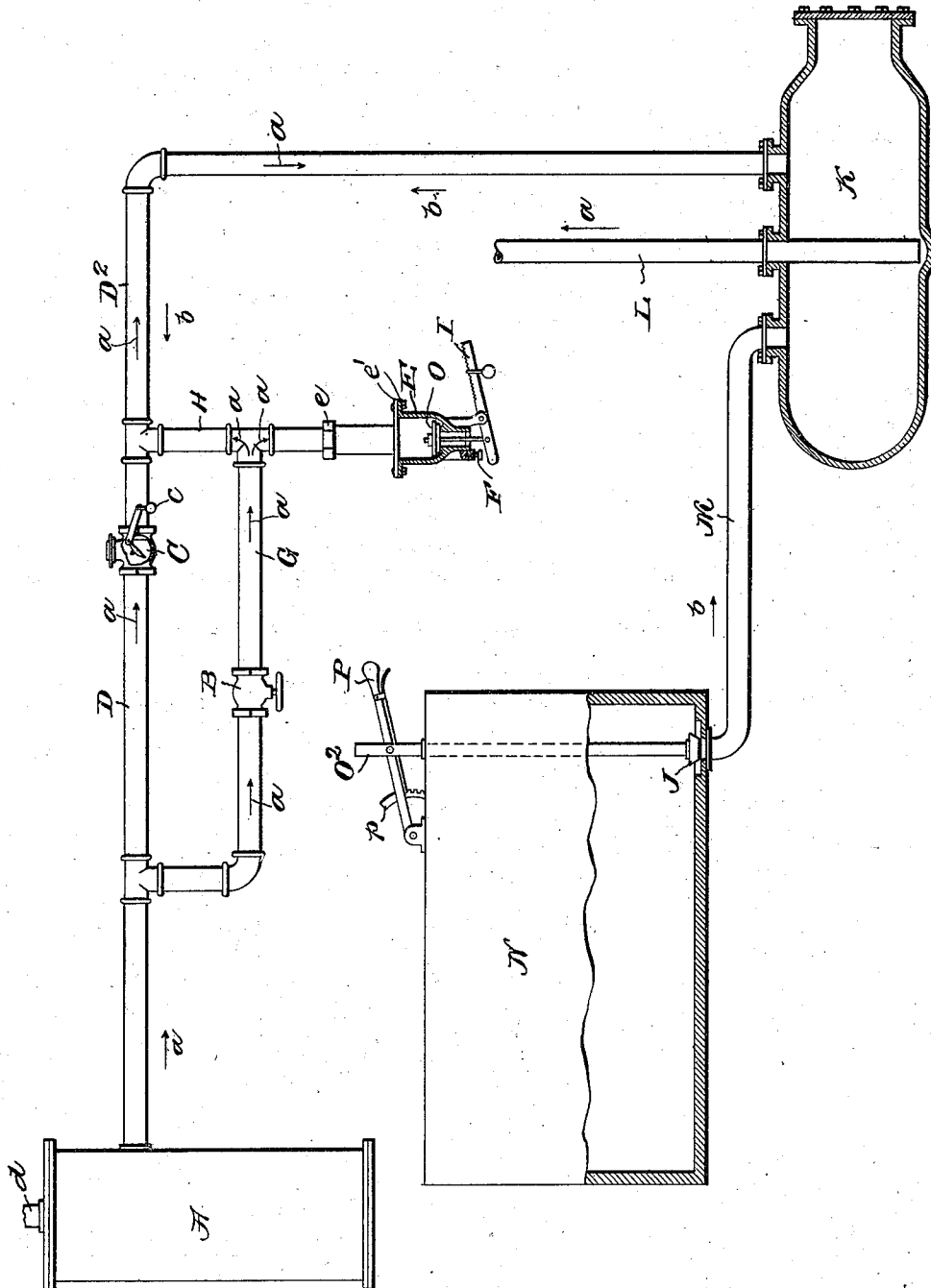

Witnesses
J. F. Neenan
T. M. Buckhead.

Inventor
Frank M. Wever,
by *Howson & Howson*,
Attorneys

UNITED STATES PATENT OFFICE.

FRANK M. WEVER, OF SAVANNAH, GEORGIA.

ACID OR OTHER LIQUID DISTRIBUTING SYSTEM.

SPECIFICATION forming part of Letters Patent No. 728,148, dated May 12, 1903.

Application filed October 18, 1902. Serial No. 127,856. (No model.)

To all whom it may concern:

Be it known that I, FRANK M. WEVER, a citizen of the United States, and a resident of Savannah, Chatham county, State of Georgia, have invented certain new and useful Improvements in Acid or other Liquid Distributing Systems, of which the following is a specification.

My invention relates to a liquid-distributing system, especially such as is employed for the transfer of acid, particularly in fertilizing plants and the like, from one point to another—as, for example, from an acid-egg to some higher point in the plant in which the same may be employed.

My object is to provide a system of this character in which all of the acid or other liquid may be readily transferred from the acid-egg by means of a fluid-pressure, such as compressed air, and the supply of such fluid immediately cut off when the acid-egg or other tank has been exhausted of all its acid or liquid, while an air-vent is at the same time automatically opened to the atmosphere to allow the escape of air from the said acid-egg or other tank in order that the same may be refilled.

In the description to follow for convenience and brevity I will describe my invention as specifically applied to an acid-transfer system; but it will be distinctly understood that it is applicable to other systems in which it may be desirable to transfer other liquids than acid from one point to another and usually from a lower to a higher level.

With this object in view my invention consists in the novel construction and combination of elements and in the details thereof as hereinafter described with reference to the accompanying drawing and more particularly pointed out in the claims hereto appended.

In the drawing is represented a side elevation, partly in section, of an apparatus embodying my invention.

Referring to the drawing, A indicates a fluid-supply tank—such, for example, as a compressed-air reservoir deriving its air-pressure through a pipe *d* from any suitable compressed-air supply. (Not deemed necessary to show or indicate in the drawing.) From this fluid-supply or compressed-air reservoir ex-

tends a pipe indicated as in two parts D and D², the latter section of which communicates with an acid reservoir or egg K, from which the said acid is to be transferred to the point desired through an acid-discharge pipe L. The acid-egg K is connected with an acid-supply reservoir or tank N by means of a pipe M, the latter of which terminates in a valve-seat in the bottom of the tank and controlled by a suitable outlet-valve J, carried by the stem O² and operated in any suitable manner, as by means of the handle P, pivotally attached to the tank and to the valve-stem O and operated in conjunction with a suitable pawl and ratchet, the latter being on the quadrant P on said tank.

Leading from any suitable point in the compressed-air-supply pipe is a branch pipe H, constituting an air-vent pipe or conduit from the said supply-pipe and terminating in a valve-casing E, in the bottom of which is an opening controlled by a normally raised valve O under the influence of a weighted lever I, so that when air is admitted to the pipe D it will pass not only through the section or part D² of said pipe into the acid-egg to exert its pressure upon the surface of the liquid therein, but it will also pass downwardly through the branch or air-vent pipe H and close the said air-vent valve to prevent escape of air while the transfer of the acid is being effected.

This construction so far described is substantially the same as that disclosed in the pending application of William L. Colson, Serial No. 108,015, filed May 19, 1902, upon which my present invention is an improvement, the features of which I will now particularly describe, and while I prefer to employ this Colson air-vent valve in my present improved system it is to be understood that the scope of my invention is not limited to the employment of any particular form of air-vent-controlling means.

In order to accomplish the object of my invention, I locate in the pipe D, between the air-supply tank and the air-vent, a suitable valve C, adapted to be normally closed by the first admission of air into the pipe D and automatically opened when substantial equalization of pressure is effected in the sections D and D² on opposite sides of said valve, the form of the valve shown in the drawing to

embody this feature of my invention being a common hinged disk or flap valve C, adapted to seat against its seat in the valve-casing, extending into the valve-chamber, and having, preferably, a weighted arm *c*, the said arm acting to open the valve both when there is no pressure in the pipe D and when there is equalization of pressure on opposite sides of the valve. Communicating with the air-vent pipe H is a by-pass conduit or pipe G, leading from the air-supply pipe at some point between the controlling-valve C and said air-supply tank A, in which by-pass conduit or pipe is an ordinary stop-valve, such as the globe-valve B, by means of which communication between the pipe D and the air-vent pipe or conduit H may be opened and closed.

In constructing the air-vent valve structure I prefer to make the chamber or casing E in two sections divided horizontally through substantially the central portion, each provided with flanges *e'*, united by suitable bolts, thereby enabling ready removal of the valve structure for inspection and repair of said valve. I also prefer to provide the upper section of the valve-chamber with a screw-threaded coupling *e* for attachment to the air-vent pipe instead of the ordinary flange-and-bolt connection of the Colson valve, hereinbefore referred to, thereby facilitating the ready application of the valve structure to and removal from the air-vent pipe. In order to provide an air-vent valve which will admit of adjustment for the various fluid or air pressures used in different plants, I attach to the valve-casing an adjusting set-screw F, by adjustment of which the extent of opening of the air-vent valve O may be regulated and dependent upon the pressure of air or fluid used in the system. In the form shown as a simple and effective mechanical device for accomplishing this purpose I employ a simple set-screw F, working in a screw-threaded recess formed in the lower part of the casing E, the head of which set-screw is adapted to contact with the end of the valve-lever I, thereby limiting the extent of upward movement of said lever, and consequently controlling and limiting the extent of opening of the valve O.

With the construction above described the mode of operation is as follows: The acid-egg K having been filled with liquid from the supply tank or reservoir N, in order to transfer the said acid or liquid by means of fluid or compressed-air pressure, the valve B being closed and the valve C likewise closed by the pressure thereupon from the tank A, the valve B is now opened, permitting compressed air to pass from the pipe D through the pipe or by-pass conduit G, thence through the valve conduit or pipe H and into the chamber E and also into the branch pipe or conduit D², the admission of pressure into said chamber E serving to close the valve O, thereby preventing escape of air while the

transferring operation is occurring. Upon the admission of air by way of the by-pass into the pipe D² and thence into the tank K the said air meets with resistance upon its contact with the surface of the liquid, thereby raising the pressure in the pipe D² to such an extent as to substantially equalize the pressure on both sides of the valve C, thus permitting the weighted arm *c* to act upon and open the valve to establish free communication from the tank A through the pipe or conduit D² into the acid-egg K, the result of which is that air-pressure will be exerted upon the surface of the liquid, forcing it through the discharge-pipe L to the point desired. In the meantime the valve B has been immediately closed after the first admission of the supplementary supply of air by way of the by-pass G, as the function of the valve C above described is effected immediately upon the admission of air or fluid through the by-pass to the liquid or acid in the egg or tank K, so that the air-pressure now exerts itself only through the pipes D and D² and the air-vent pipe H, in the latter of which the air or fluid performs the function of holding the air-vent valve E closed, as in the Colson valve embodied in the application above referred to. The moment all of the liquid has been transferred from the acid egg or tank K the pressure of the air in the tank is reduced, and the velocity of the air in the section D of the air-supply pipe is so accelerated as to close the valve C by reason of the release of resistance to the pressure of the air upon the liquid in the tank K, thereby cutting off further supply of air to said tank, and such reduction of pressure in the section D² permits the air-vent valve E to unseat and open the air-vent passage, thus establishing a vent from the tank K to the atmosphere and allowing the refilling of said acid-egg. I have indicated by the arrows marked *a* the course of the air and liquid during the transferring operation and by the arrows indicated by the letter *b* the course of these fluids during the refilling operation of the tank or egg K.

By the use of my improved system a two-fold advantage is attained in that all of the liquid to be transferred or discharged from the tank or egg K is exhausted therefrom and the fluid or air pressure is automatically shut off from said tank the moment the last of the liquid is discharged therefrom, thus effectually preventing any escape of air through the discharge-pipe from said tank, while at the same time the air-vent is opened, thus allowing the refilling operation to proceed at will. The valve B, it will be observed, is controllable at will, so that the filling and discharging operations may be repeated in the manner above described as often as desired by simply opening said valve B to permit the passage of air or fluid pressure to the tank and the air-vent valve through the by-pass and then immediately shut off when said pres-

sure has accomplished its function of automatically opening the valve C for communication between the tank A and the acid-egg K.

I claim as my invention—

5 1. In an acid or other liquid distributing system, the combination with a transfer tank or reservoir, a fluid-pressure supply, a pipe or conduit communicating therewith and an air-vent communicating with said fluid-pressure supply normally closed while the pressure is being supplied to said tank and opened when being refilled, of a valve interposed in said pipe between said air-vent and fluid-pressure supply and automatically operated to open for admission of pressure to the said reservoir for transfer of the liquid, and a valve-controlled by-pass around said valve to the air-vent, substantially as described.

20 2. In an acid or other liquid distributing system, the combination with a transfer tank or reservoir, a fluid-pressure supply, a pipe or conduit communicating therewith and an air-vent communicating with said fluid-pressure supply normally closed while the pressure is being supplied to said tank and opened when being refilled, of a valve interposed in said pipe between said air-vent and fluid-pressure supply and automatically operated to open for admission of pressure to the said reservoir for transfer of the liquid, substantially as described.

35 3. In an acid or other liquid distributing system, the combination with an acid-egg, an air or other fluid pressure supply tank, a pipe or conduit connecting the two, and an air-vent interposed in said pipe provided with an automatically-operated air-vent valve to permit escape of air from the egg while it is being filled and closed against the escape of said air when the fluid-pressure supply is admitted thereto for the transferring of liquid therefrom, of an automatically-operated valve between said air-vent and the fluid-pressure-supply tank opened by equalization of air-pressure on both sides thereof when air is admitted to the tank for transfer of the liquid and closed when said tank is being refilled, and a valve-controlled by-pass in communication with the fluid-pressure tank and communicating with the air-vent, substantially as described.

40 4. In an acid or other liquid distributing system, the combination with an acid-egg, an air or other fluid pressure supply tank, a pipe or conduit connecting the two, and an air-vent interposed in said pipe provided with an air-vent valve to permit escape of air from the egg while it is being filled and closed against the escape of said air when the fluid-pressure supply is admitted thereto for the transferring of liquid therefrom, of an automatically-operated valve between said air-vent and the fluid-pressure-supply tank opened by equalization of air-pressure on both sides thereof when air is admitted to the tank for transfer of the liquid and closed when said tank is being refilled, and a valve-

controlled by-pass in communication with the fluid-pressure tank and communicating with the air-vent, substantially as described. 70

5. The combination with the fluid-pressure-supply tank, an acid or other liquid transfer tank and a pipe or conduit connecting the two, of an air-vent valve structure interposed in said supply-pipe between the two tanks, a valve normally closed by the pressure in said pipe to prevent the escape of air therefrom and automatically opened to permit the escape of air therefrom when the acid or other liquid is exhausted from the transfer-tank, and means for adjusting the extent of opening of said valve, substantially as described. 75 80

6. The combination with a fluid-pressure-supply tank, an acid or other liquid transfer tank and a pipe or conduit connecting the two, of an air-vent valve structure interposed in said supply-pipe between the two tanks, a valve closed to prevent the escape of air from the supply-pipe, a weighted lever normally tending to open the valve, and an adjusting set-screw for varying the amount of opening of the valve, substantially as described. 85 90

7. The combination with a fluid-pressure-supply tank or reservoir, an acid or other liquid transfer tank or reservoir, a pipe or conduit connecting the two, and an air-vent valve structure interposed in the said pipe or conduit between the two tanks or reservoirs, of a valve controlled by the pressure of air in said pipe or conduit and located therein between the air-vent structure and the fluid-pressure-supply reservoir or tank and normally closed by the air-pressure in said supply-reservoir, a by-pass from said reservoir around the said valve and controllable at will to admit pressure from the fluid-pressure-supply reservoir to the air-vent structure and the transfer-tank, substantially as described. 95 100 105

8. In a liquid-distributing system, the combination with a fluid-pressure-supply reservoir, a liquid-transfer tank communicating by a supply pipe or conduit with said reservoir, and an air-vent structure in said system, of means for admitting air-pressure from the reservoir to the transfer-tank at will to cause the transfer of liquid therefrom and automatically shutting off the supply of air-pressure when all the liquid is exhausted therefrom, substantially as described. 110 115

9. In a liquid-distributing system, the combination with a compressed-air-supply reservoir, a liquid-transfer tank communicating therewith by a conduit or pipe, and an air-vent valve in said pipe or conduit adapted to prevent escape of air from the system when liquid is being discharged from the transfer-tank and opened when liquid is being supplied to said tank, of an automatically-acting air-supply valve controlled by the pressure of air in the said pipe or conduit for establishing direct communication therethrough between the tank and reservoir, and a valved by-pass controllable at will for admitting air to the air-vent valve and the transfer-tank 120 125 130

to cause the former to close and to cause equalization of pressure on both sides of the air-supply valve, whereby air-pressure is admitted to the transfer-tank for transferring
5 the liquid therefrom, substantially as described.

10 10. In a liquid-distributing system, the combination with a compressed-air-supply tank or reservoir, a liquid-transfer tank, a pipe or
15 conduit connecting the two, an air-vent pipe communicating with said air-supply pipe, and a valve in said pipe normally closed by the direct air-pressure thereon, of an air-supply valve in said air-supply pipe or conduit
15 between the air-vent pipe and the air-supply reservoir normally closed by the pressure of air from the supply-tank, a by-pass from the supply-tank around said air-supply valve,

and a valve in said by-pass controllable at will to first admit air to the air-vent pipe and
20 to the transfer-tank and then to cut off said air when the air-pressure substantially equalizes on each side of the air-supply valve, whereby air-pressure is admitted through the
25 air-supply pipe and by way of the by-pass to the transfer-tank and the air-supply valve automatically closed when the liquid is exhausted therefrom, substantially as described.

In testimony whereof I have signed my
30 name to this specification in the presence of two subscribing witnesses.

FRANK M. WEVER.

Witnesses:

GEO. L. GARMANY,
JOS. M. BRODERICK.