



(12) **EUROPEAN PATENT APPLICATION**

(88) Date of publication A3:
08.07.1998 Bulletin 1998/28

(51) Int Cl.6: **B42F 13/00**

(43) Date of publication A2:
22.10.1997 Bulletin 1997/43

(21) Application number: **97850060.1**

(22) Date of filing: **17.04.1997**

(84) Designated Contracting States:
DE DK FI FR GB IT

(72) Inventor: **Andersson, Björn**
149 50 Nynäshamn (SE)

(30) Priority: **18.04.1996 SE 9601480**

(74) Representative: **Karlsson, Leif Karl Gunnar et al**
L.A. Groth & Co. KB,
Box 6107
102 32 Stockholm (SE)

(71) Applicant: **Northern Marine Investment Co.**
Limited
Jersey JE4 9NU, Channel Islands (GB)

(54) **Cover blank**

(57) A cover blank 1) and a method for fabricating a cover blank (1) consisting of a board with the thickness 7 and a size corresponding to a completed binder's front cover, spine and rear cover, the outside (2) of the cover blank (1) being provided with four parallel grooves (7, 8, 9, 10), two of said grooves constituting opening grooves (7, 8) and the other two constituting mechanism grooves

(9,10), the inside (3) of the cover blank (1) is supplied with two parallel spine grooves (11, 12), a binder is manufactured from a cover blank, the cover blank (1) being bilaterally lined, at least one countersunk label area (13, 14) is formed by the stamping of a binder cover (4, 5) and/or binder spine and the mechanism is mounted at the intended site, thereby forming a completed binder.

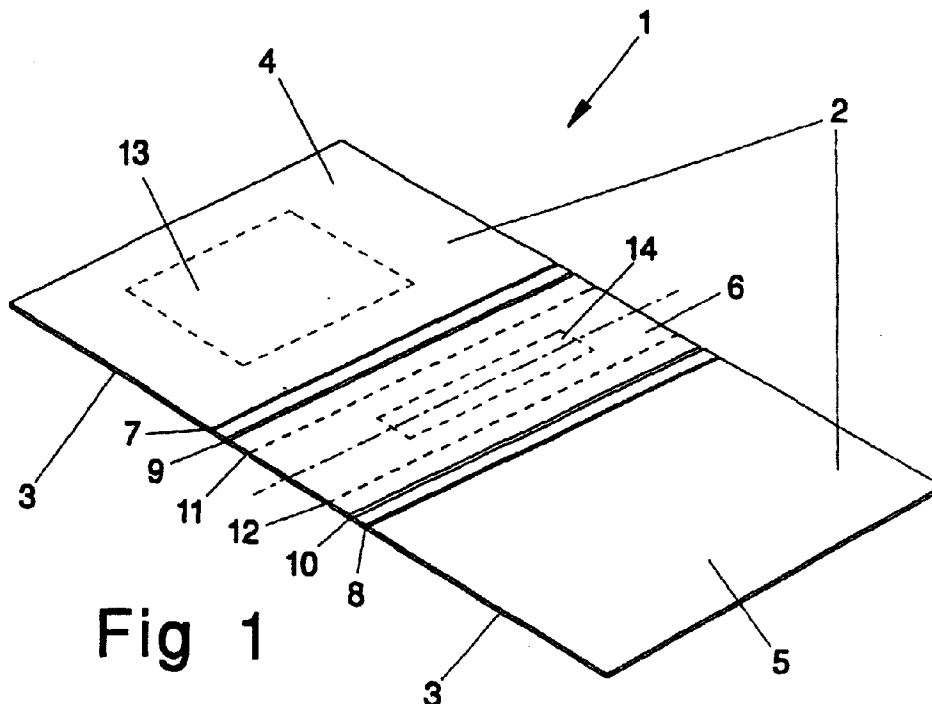

Fig 1



European Patent
Office

EUROPEAN SEARCH REPORT

Application Number
EP 97 85 0060

DOCUMENTS CONSIDERED TO BE RELEVANT			
Category	Citation of document with indication, where appropriate, of relevant passages	Relevant to claim	CLASSIFICATION OF THE APPLICATION (Int.Cl.6)
A	US 3 884 742 A (ROBERTS) 20 May 1975 * the whole document * ---	1,12	B42F13/00
A	GB 1 214 477 A (FOULEY PLASTICS MANUFACTURING) 2 December 1970 * the whole document * ---	1,12	
A	EP 0 504 566 A (HEIN) 23 September 1992 * the whole document * -----	1,12	
The present search report has been drawn up for all claims			TECHNICAL FIELDS SEARCHED (Int.Cl.6)
			B42F B42D B42C
Place of search	Date of completion of the search	Examiner	
THE HAGUE	19 May 1998	Evans, A	
CATEGORY OF CITED DOCUMENTS		T : theory or principle underlying the invention E : earlier patent document, but published on, or after the filing date D : document cited in the application L : document cited for other reasons & : member of the same patent family, corresponding document	
X : particularly relevant if taken alone Y : particularly relevant if combined with another document of the same category A : technological background O : non-written disclosure P : intermediate document			

EPO FORM 1503 03/82 (P04C01)