

(19)



Europäisches Patentamt
European Patent Office
Office européen des brevets



(11)

EP 0 822 041 A3

(12)

EUROPEAN PATENT APPLICATION

(88) Date of publication A3:
24.03.1999 Bulletin 1999/12

(51) Int Cl.6: B27D 1/08, B30B 5/02

(43) Date of publication A2:
04.02.1998 Bulletin 1998/06

(21) Application number: 97202351.9

(22) Date of filing: 25.07.1997

(84) Designated Contracting States:
AT BE CH DE DK ES FI FR GB GR IE IT LI LU MC
NL PT SE
Designated Extension States:
AL LT LV RO SI

(72) Inventor: De Zanet, Benigno
32037 Sospirolo (Belluno) (IT)

(74) Representative: Mittler, Enrico
c/o Mittler & C. s.r.l.,
Viale Lombardia, 20
20131 Milano (IT)

(30) Priority: 31.07.1996 IT MI961645

(71) Applicant: Xilofarm S.p.A.
32035 S. Giustina (Belluno) (IT)

(54) Process and machine for manufacturing shaped profiles in curved plywood, particularly for covering pipes and the like

(57) A process and a machine for manufacturing shaped profiles in curved plywood are described. A set of flat wooden sheets (1) with interposed adhesive (2) is submitted at temperature and pressure by means of a shaped press (3) at high temperature to determine the

mutual adhesion of the sheets themselves and their bending up to the desired shape. Press (3) is operated against a counterpress (4) shaped in substantially complementary way which causes the lateral block of the flat overlaid sheets (1) before the application of a final sheet bending pressure.

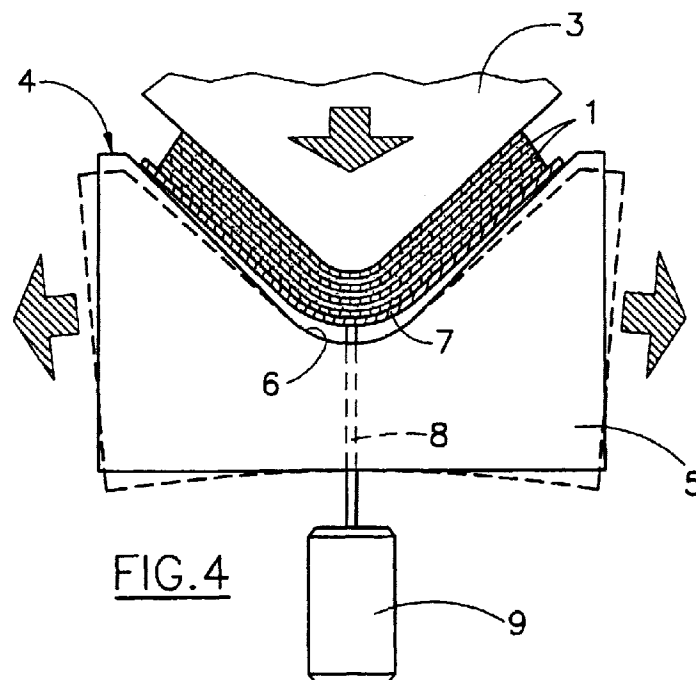

FIG. 4

EP 0 822 041 A3



European Patent Office

EUROPEAN SEARCH REPORT

Application Number
EP 97 20 2351

DOCUMENTS CONSIDERED TO BE RELEVANT			
Category	Citation of document with indication, where appropriate, of relevant passages	Relevant to claim	
A	US 4 484 609 A (WEAVER HENRY J) 27 November 1984 * column 2, line 11 - column 3, line 45; figures * ---	1,3	
A	US 3 816 044 A (NIELSEN H ET AL) 11 June 1974 ---		
A	US 2 418 100 A (STEWART) 25 March 1947 ---		
A	DE 889 066 C (LIESKE) ---		
A	FR 906 269 A (BEHR) ---		
A	FR 1 358 646 A (HENNEQUIN) 22 July 1964 -----		
			CLASSIFICATION OF THE APPLICATION (Int.Cl.6)
			TECHNICAL FIELDS SEARCHED (Int.Cl.6)
			B27D B30B
The present search report has been drawn up for all claims			
Place of search	Date of completion of the search	Examiner	
THE HAGUE	28 January 1999	Huggins, J	
CATEGORY OF CITED DOCUMENTS		T : theory or principle underlying the invention	
X : particularly relevant if taken alone		E : earlier patent document, but published on, or after the filing date	
Y : particularly relevant if combined with another document of the same category		D : document cited in the application	
A : technological background		L : document cited for other reasons	
O : non-written disclosure		
P : intermediate document		& : member of the same patent family, corresponding document	

EPO FORM 1503 03.92 (P04C01)

ANNEX TO THE EUROPEAN SEARCH REPORT
ON EUROPEAN PATENT APPLICATION NO.

EP 97 20 2351

This annex lists the patent family members relating to the patent documents cited in the above-mentioned European search report. The members are as contained in the European Patent Office EDP file on
The European Patent Office is in no way liable for these particulars which are merely given for the purpose of information.

28-01-1999

Patent document cited in search report	Publication date	Patent family member(s)	Publication date
US 4484609 A	27-11-1984	NONE	
US 3816044 A	11-06-1974	NONE	
US 2418100 A	25-03-1947	NONE	
DE 889066 C		NONE	
FR 906269 A		NONE	
FR 1358646 A	22-07-1964	NONE	

EPO FORM P0459

For more details about this annex : see Official Journal of the European Patent Office, No. 12/82