

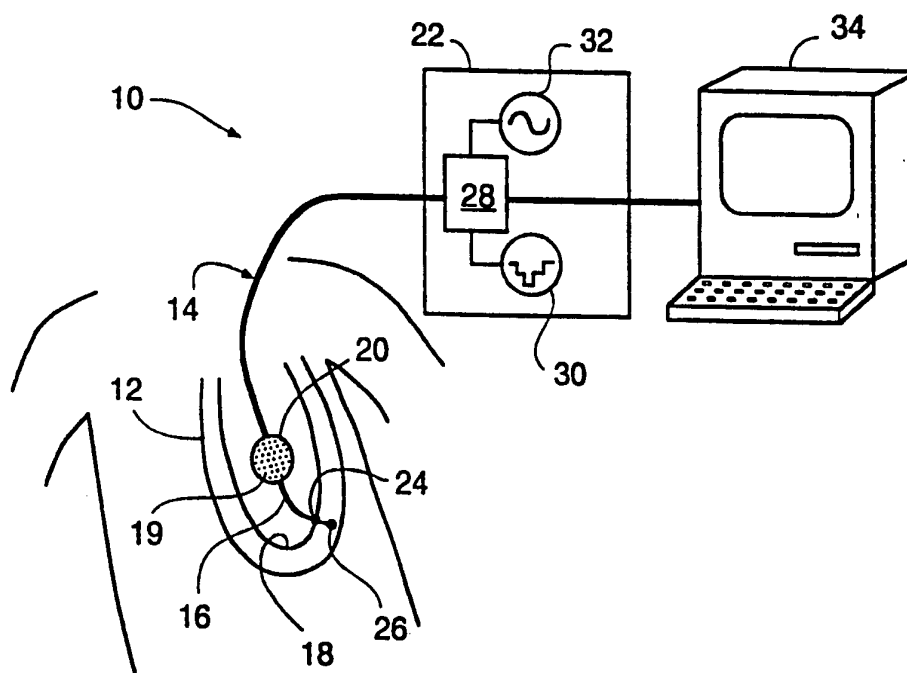

## INTERNATIONAL APPLICATION PUBLISHED UNDER THE PATENT COOPERATION TREATY (PCT)

<p>(51) International Patent Classification <sup>5</sup> : <b>A61B 5/042, 5/0408</b></p>	<p><b>A1</b></p>	<p>(11) International Publication Number: <b>WO 94/06349</b> (43) International Publication Date: 31 March 1994 (31.03.94)</p>
<p>(21) International Application Number: PCT/US93/09015 (22) International Filing Date: 23 September 1993 (23.09.93) (30) Priority data: 07/949,690 23 September 1992 (23.09.92) US 07/950,448 23 September 1992 (23.09.92) US (60) Parent Applications or Grants (63) Related by Continuation US 07/949,690 (CIP) Filed on 23 September 1992 (23.09.92) US 07/950,448 (CIP) Filed on 23 September 1992 (23.09.92) (71) Applicant (for all designated States except US): ENDO-CARDIAL THERAPEUTICS, INC. [US/US]; 5112 Russel Avenue South, Minneapolis, MN 55410 (US).</p>		<p>(72) Inventors; and (75) Inventors/Applicants (for US only) : BEATTY, Graydon, Ernest [US/US]; 1935 Summit Avenue, St. Paul, MN 55105 (US). KAGAN, Jonathan [US/US]; 5112 Russel Avenue South, Minneapolis, MN 55410 (US). BUDD, Jeffrey, R. [US/US]; 2261 Gordon Avenue, St. Paul, MN 55112 (US). (74) Agent: BRUESS, Steven, C.; Merchant, Gould, Smith, Edell, Welter &amp; Schmidt, 3100 Norwest Center, 90 South Seventh Street, Minneapolis, MN 55402 (US). (81) Designated States: CA, JP, US, European patent (AT, BE, CH, DE, DK, ES, FR, GB, GR, IE, IT, LU, MC, NL, PT, SE).  <b>Published</b> <i>With international search report. Before the expiration of the time limit for amending the claims and to be republished in the event of the receipt of amendments.</i></p>

(54) Title: ENDOCARDIAL MAPPING SYSTEM



## (57) Abstract

A system for mapping electrical activity of a patient's heart includes a set of electrodes (19) spaced from the heart wall (18) and a set of electrodes (24, 26) in contact with the heart wall (18). Voltage measurements from the electrodes are used to generate three-dimensional and two-dimensional maps of the electrical activity of the heart.

**FOR THE PURPOSES OF INFORMATION ONLY**

Codes used to identify States party to the PCT on the front pages of pamphlets publishing international applications under the PCT.

AT	Austria	FR	France	MR	Mauritania
AU	Australia	GA	Gabon	MW	Malawi
BB	Barbados	GB	United Kingdom	NE	Niger
BE	Belgium	GN	Guinea	NL	Netherlands
BF	Burkina Faso	GR	Greece	NO	Norway
BG	Bulgaria	HU	Hungary	NZ	New Zealand
BJ	Benin	IE	Ireland	PL	Poland
BR	Brazil	IT	Italy	PT	Portugal
BY	Belarus	JP	Japan	RO	Romania
CA	Canada	KP	Democratic People's Republic of Korea	RU	Russian Federation
CF	Central African Republic	KR	Republic of Korea	SD	Sudan
CG	Congo	KZ	Kazakhstan	SE	Sweden
CH	Switzerland	LI	Liechtenstein	SI	Slovenia
CI	Côte d'Ivoire	LK	Sri Lanka	SK	Slovak Republic
CM	Cameroon	LU	Luxembourg	SN	Senegal
CN	China	LV	Latvia	TD	Chad
CS	Czechoslovakia	MC	Monaco	TG	Togo
CZ	Czech Republic	MG	Madagascar	UA	Ukraine
DE	Germany	ML	Mali	US	United States of America
DK	Denmark	MN	Mongolia	UZ	Uzbekistan
ES	Spain			VN	Viet Nam
FI	Finland				

ENDOCARDIAL MAPPING SYSTEMTechnical Field

The invention discloses the apparatus and technique  
5 for forming a three-dimensional electrical map of the  
interior of a heart chamber, and a related technique for  
forming a two-dimensional subsurface map at a particular  
location in the endocardial wall.

10 Background Art

It is common to measure the electrical potentials  
present on the interior surface of the heart as a part  
of an electrophysiologic study of a patient's heart.  
Typically such measurements are used to form a two-  
15 dimensional map of the electrical activity of the heart  
muscle. An electrophysiologist will use the map to  
locate centers of ectopic electrical activity occurring  
within the cardiac tissues. One traditional mapping  
technique involves a sequence of electrical measurements  
20 taken from mobile electrodes inserted into the heart  
chamber and placed in contact with the surface of the  
heart. An alternative mapping technique takes  
essentially simultaneous measurements from a floating  
electrode array to generate a two-dimensional map of  
25 electrical potentials.

The two-dimensional maps of the electrical  
potentials at the endocardial surface generated by these  
traditional processes suffer many defects. Traditional  
systems have been limited in resolution by the number of  
30 electrodes used. The number of electrodes dictated the  
number of points for which the electrical activity of  
the endocardial surface could be mapped. Therefore,  
progress in endocardial mapping has involved either the  
introduction of progressively more electrodes on the  
35 mapping catheter or improved flexibility for moving a  
small mapping probe with electrodes from place to place  
on the endocardial surface. Direct contact with  
electrically active tissue is required by most systems  
in the prior art in order to obtain well conditioned

electrical signals. An exception is a non-contact approach with spot electrodes. These spot electrodes spatially average the electrical signal through their conical view of the blood media. This approach  
5 therefore also produces one signal for each electrode. The small number of signals from the endocardial wall will result in the inability to accurately resolve the location of ectopic tissue masses. In the prior art, iso-potentials are interpolated and plotted on a  
10 rectilinear map which can only crudely represent the unfolded interior surface of the heart. Such two-dimensional maps are generated by interpolation processes which "fill in" contours based upon a limited set of measurements. Such interpolated two-dimensional  
15 maps have significant deficiencies. First, if a localized ectopic focus is between two electrode views such a map will at best show the ectopic focus overlaying both electrodes and all points in between and at worst will not see it at all. Second, the two  
20 dimensional map, since it contains no chamber geometry information, cannot indicate precisely where in the three dimensional volume of the heart chamber an electrical signal is located. The inability to accurately characterize the size and location of ectopic  
25 tissue frustrates the delivery of certain therapies such as "ablation".

#### Summary Disclosure

In general the present invention provides a method  
30 for producing a high-resolution, three-dimensional map of electrical activity of the inside surface of a heart chamber.

The invention uses a specialized catheter system to obtain the information necessary to generate such a map.

35 In general the invention provides a system and method which permits the location of catheter electrodes to be visualized in the three-dimensional map.

The invention may also be used to provide a two-dimensional map of electrical potential at or below the myocardial tissue surface.

Additional features of the invention will appear from the following description in which the illustrative embodiment is set forth in detail in conjunction with the accompanying drawings. It should be understood that many modifications to the invention, and in particular to the preferred embodiment illustrated in these drawings, may be made without departing from the scope of the invention.

Figure 1 is a schematic view of the system.

Figure 2 is a view of the catheter assembly placed in an endocardial cavity.

Figure 3 is a schematic view of the catheter assembly.

Figure 4 is a view of the mapping catheter with the deformable lead body in the collapsed position.

Figure 5 is a view of the mapping catheter with the deformable lead body in the expanded position.

Figure 6 is a view of the reference catheter.

Figure 7 is a schematic view representing the display of the three-dimensional map.

Figure 8 is a side view of an alternate reference catheter.

Figure 9 is a side view of an alternate reference catheter.

Figure 10 is a perspective view of an alternate distal tip.

Figure 11 is a schematic view representing the display of the subsurface two-dimensional map.

Figure 12 is a schematic flow chart of the steps in the method.

#### Detailed Disclosure

In general, the system of the present invention is used for mapping the electrical activity of the interior

surface of a heart chamber 80. The mapping catheter assembly 14 includes a flexible lead body 72 connected to a deformable distal lead body 74. The deformable distal lead body 74 can be formed into a stable space filling geometric shape after introduction into the heart cavity 80. This deformable distal lead body 74 includes an electrode array 19 defining a number of electrode sites. The mapping catheter assembly 14 also includes a reference electrode preferably placed on a reference catheter 16 which passes through a central lumen 82 formed in the flexible lead body 72 and the distal lead body 74. The reference catheter assembly 16 has a distal tip electrode assembly 24 which may be used to probe the heart wall. This distal contact electrode assembly 24 provides a surface electrical reference for calibration. The physical length of the reference catheter 16 taken with the position of the electrode array 19 together provide a reference which may be used to calibrate the electrode array 19. The reference catheter 16 also stabilizes the position of the electrode array 19 which is desirable.

These structural elements provide a mapping catheter assembly which can be readily positioned within the heart and used to acquire highly accurate information concerning the electrical activity of the heart from a first set of preferably non-contact electrode sites and a second set of in-contact electrode sites.

The mapping catheter assembly 14 is coupled to interface apparatus 22 which contains a signal generator 32, and voltage acquisition apparatus 30. Preferably, in use, the signal generator 32 is used to measure the volumetric shape of the heart chamber through impedance plethysmography. This signal generator is also used to determine the position of the reference electrode within the heart chamber. Other techniques for characterizing the shape of the heart chamber may be substituted.

Next, the signals from all the electrode sites on the electrode array 19 are presented to the voltage acquisition apparatus 30 to derive a three-dimensional, instantaneous high resolution map of the electrical activity of the entire heart chamber volume. This map is calibrated by the use of a surface electrode 24. The calibration is both electrical and dimensional. Lastly this three-dimensional map, along with the signal from an intramural electrode 26 preferably at the tip of the reference catheter 16, is used to compute a two-dimensional map of the intramural electrical activity within the heart wall. The two-dimensional map is a slice of the heart wall and represents the subsurface electrical activity in the heart wall itself.

Both of these "maps" can be followed over time which is desirable. The true three-dimensional map also avoids the problem of spatial averaging and generates an instantaneous, high resolution map of the electrical activity of the entire volume of the heart chamber and the endocardial surface. This three-dimensional map is an order of magnitude more accurate and precise than previously obtained interpolation maps. The two-dimensional map of the intramural slice is unavailable using prior techniques.

25

#### Hardware Description

Figure 1 shows the mapping system 10 coupled to a patient's heart 12. The mapping catheter assembly 14 is inserted into a heart chamber and the reference electrode 24 touches the endocardial surface 18.

The preferred array catheter 20 carries at least twenty-four individual electrode sites which are coupled to the interface apparatus 22. The preferred reference catheter 16 is a coaxial extension of the array catheter 20. This reference catheter 16 includes a surface electrode site 24 and a subsurface electrode site 26 both of which are coupled to the interface apparatus 22.

It should be understood that the electrode site 24 can be located directly on the array catheter. The array catheter 20 may be expanded into a known geometric shape, preferably spherical. Resolution is enhanced by the use of larger sized spherical shapes. A balloon 77 or the like should be incorporated under the electrode array 19 to exclude blood from the interior of the electrode array 19. The spherical shape and exclusion of blood are not required for operability but they materially reduce the complexity of the calculations required to generate the map displays.

The reference electrode 24 and/or the reference catheter 16 serves several purposes. First they stabilize and maintain the array 19 at a known distance from a reference point on the endocardial surface 18 for calibration of the shape and volume calculations. Secondly, the surface electrode 24 is used to calibrate the electrical activity measurements of the endocardial surface 18 provided by the electrode array 19.

The interface apparatus 22 includes a switching assembly 28 which is a multiplexor to sequentially couple the various electrode sites to the voltage acquisition apparatus 30, and the signal generator apparatus 32. These devices are under the control of a computer 34. The voltage acquisition apparatus 30 is preferably a 12 bit A to D convertor. A signal generator 32 is also supplied to generate low current pulses for determining the volume and shape of the endocardial chamber using impedance plethysmography, and for determining the location of the reference catheter.

The computer 34 is preferably of the "workstation" class to provide sufficient processing power to operate in essentially real time. This computer operates under the control of software set forth in the flow charts of Figures 12A and 12B.



### Catheter Description

Figure 2 shows a portion of the mapping catheter assembly 14 placed into a heart chamber 80. The mapping catheter assembly 14 includes a reference catheter 16 and an array catheter 20. In Figure 2 the array catheter 20 has been expanded through the use of a stylet 92 to place the electrode array 19 into a stable and reproducible geometric shape. The reference catheter 16 has been passed through the lumen 82 of the array catheter 20 to place a distal tip electrode assembly 24 into position against an endocardial surface. In use, the reference catheter 16 provides a mechanical location reference for the position of the electrode array 19, and the tip electrode assembly 24 provides an electrical potential reference at or in the heart wall for the mapping process.

Although the structures of Figure 1 are preferred there are several alternatives within the scope of the invention. The principle objective of the preferred form of the catheter system is to reliably place a known collection of electrode sites away from the endocardial surface, and one or more electrode sites into contact with the endocardium. The array catheter is an illustrative structure for placing at least some of the electrode sites away from the endocardial surface. The array catheter itself can be designed to mechanically position one or more electrode sites on the endocardial surface. The reference catheter is a preferred structure for carrying one or more electrode sites and may be used to place these electrode sites into direct contact with the endocardial surface.

It should be understood that the reference catheter could be replaced with a fixed extension of the array catheter and used to push a segment of the array onto the endocardial surface. In this alternate embodiment the geometric shape of the spherical array maintains the other electrodes out of contact with the endocardial

surface.

Figure 3 shows the preferred construction of the mapping catheter assembly 14 in exaggerated scale to clarify details of construction. In general, the array catheter 20 includes a flexible lead body 72 coupled to a deformable lead body 74. The deformable lead body 74 is preferably a braid 75 of insulated wires, several of which are shown as wire 93, wire 94, wire 95 and wire 96. An individual wire such as 93 may be traced in the figure from the electrical connection 79 at the proximal end 81 of the flexible lead body 72 through the flexible lead body 72 to the distal braid ring 83 located on the deformable lead body 74. At a predetermined location in the deformable lead body 74 the insulation has been selectively removed from this wire 93 to form a representative electrode site 84. Each of the several wires in the braid 75 may potentially be used to form an electrode site. Preferably all of the typically twenty-four to one-hundred-twenty-eight wires in the braid 75 are used to form electrode sites. Wires not used as electrode sites provide mechanical support for the electrode array 19. In general, the electrode sites will be located equidistant from a center defined at the center of the spherical array. Other geometrical shapes are usable including ellipsoidal and the like.

The proximal end 81 of the mapping catheter assembly 14 has suitable electrical connection 79 for the individual wires connected to the various electrode sites. Similarly the proximal connector 79 can have a suitable electrical connection for the distal tip electrode assembly 24 of the reference catheter 16 or the reference catheter 16 can use a separate connector. The distance 90 between the electrode array 19 and the distal tip assembly 24 electrode can preferentially be varied by sliding the reference catheter through the lumen 82, as shown by motion arrow 85. This distance 90 may be "read" at the proximal end 81 by noting the

relative position of the end of the lead body 72 and the proximal end of the reference catheter 16.

Figure 4 is a view of the mapping catheter with the deformable lead body 74 in the collapsed position.

5        Figure 5 shows that the wire stylet 92 is attached to the distal braid ring 83 and positioned in the lumen 82. Traction applied to the distal braid ring 83 by relative motion of the stylet 92 with respect to the lead body 72 causes the braid 75 to change shape. In  
10        general, traction causes the braid 75 to move from a generally cylindrical form seen in Figure 4 to a generally spherical form seen best in Figure 2 and Figure 5.

      The preferred technique is to provide a stylet 92  
15        which can be used to pull the braid 75 which will deploy the electrode array 19. However, other techniques may be used as well including an optional balloon 77 shown as in Figure 3, which could be inflated under the electrode array 19 thereby causing the spherical  
20        deployment of the array 19. Modification of the braid 75 can be used to control the final shape of the array 19. For example an asymmetrical braid pattern using differing diameter wires within the braid can preferentially alter the shape of the array. The most  
25        important property of the geometric shape is that it spaces the electrode sites relatively far apart and that the shape be predictable with a high degree of accuracy.

      Figure 6 shows a first embodiment of the reference catheter 16 where the distal electrode assembly 24 is  
30        blunt and may be used to make a surface measurement against the endocardial surface. In this version of the catheter assembly the wire 97 (Figure 2) communicates to the distal tip electrode and this wire may be terminated in the connector 79.

35        Figure 8 shows an alternate reference catheter 98 which is preferred if both surface and/or subsurface measurements of the potential proximate the endocardial

surface are desired. This catheter 98 includes both a reference electrode 24 and an extendable intramural electrode body 100.

Figure 9 illustrates the preferred use of an intramural electrode stylet 101 to retract the sharp intramural electrode body 100 into the reference catheter lead body 102. Motion of the intramural electrode body 100 into the lead body 102 is shown by arrow 103.

Figure 10 shows the location of the intramural electrode site 26 on the electrode body 100. It is desirable to use a relatively small electrode site to permit localization of the intramural electrical activity.

The array catheter 20 may be made by any of a variety of techniques. In one method of manufacture, the braid 75 of insulated wires 93,94,95,96 can be encapsulated into a plastic material to form the flexible lead body 72. This plastic material can be any of various biocompatible compounds with polyurethane being preferred. The encapsulation material for the flexible lead body 72 is selected in part for its ability to be selectively removed to expose the insulated braid 75 to form the deformable lead body 74. The use of a braid 75 rather than a spiral wrap, axial wrap, or other configuration inherently strengthens and supports the electrodes due to the interlocking nature of the braid. This interlocking braid 75 also insures that, as the electrode array 19 deploys, it does so with predictable dimensional control. This braid 75 structure also supports the array catheter 20 and provides for the structural integrity of the array catheter 20 where the encapsulating material has been removed.

To form the deformable lead body 74 at the distal end of the array catheter 20, the encapsulating material can be removed by known techniques. In a preferred

embodiment this removal is accomplished by mechanical removal of the encapsulating material by grinding or the like. It is also possible to remove the material with a solvent. If the encapsulating material is polyurethane, 5 tetrahydrofuran or cyclohexanone can be used as a solvent. In some embodiments the encapsulating material is not removed from the extreme distal tip to provide enhanced mechanical integrity forming a distal braid ring 83.

10 With the insulated braid 75 exposed, to form the deformable lead body 74 the electrodes sites can be formed by removing the insulation over the conductor in selected areas. Known techniques would involve mechanical, thermal or chemical removal of the 15 insulation followed by identification of the appropriate conducting wire at the proximal connector 79. This method makes it difficult to have the orientation of the proximal conductors in a predictable repeatable manner. Color coding of the insulation to enable selection of 20 the conductor/electrode is possible but is also difficult when large numbers of electrodes are required. Therefore it is preferred to select and form the electrode array through the use of high voltage electricity. By applying high voltage electricity 25 (typically 1-3 KV) to the proximal end of the conductor and detecting this energy through the insulation it is possible to facilitate the creation of the electrode on a known conductor at a desired location. After localization, the electrode site can be created by 30 removing insulation using standard means or by applying a higher voltage (eg. 5 KV) to break through the insulation.

Modifications can be made to this mapping catheter assembly without departing from the teachings of the 35 present invention. Accordingly the scope of the invention is only to be limited only by the accompanying claims.

### Software Description

The illustrative method may be partitioned into nine steps as shown in Figure 12. The partitioning of the step-wise sequence is done as an aid to explaining the invention and other equivalent partitioning can be readily substituted without departing from the scope of the invention.

At step 41 the process begins. The illustrative process assumes that the electrode array assumes a known spherical shape within the heart chamber, and that there are at least twenty-four electrodes on the electrode array 19. This preferred method can be readily modified to accommodate unknown and non-reproducible, non-spherical shaped arrays. The location of each of these electrode sites on the array surface is known from the mechanical configuration of the displayed array. A method of determining the location of the electrode array 19 and the location of the heart chamber walls (cardiac geometry) must be available. This geometry measurement (options include ultrasound or impedance plethysmography) is performed in step 41. If the reference catheter 16 is extended to the chamber wall 18 then its length can be used to calibrate the geometry measurements since the calculated distance can be compared to the reference catheter length. The geometry calculations are forced to converge on the known spacing represented by the physical dimensions of the catheters. In an alternative embodiment reference electrode 24 is positioned on array catheter 20 and therefore its position would be known.

In step 42 the signals from all the electrode sites in the electrode array 19 are sampled by the A to D converter in the voltage acquisition apparatus 30. These measurements are stored in a digital file for later use in following steps. At this point (step 43) the known locations of all the electrodes on the electrode array 19 and the measured potentials at each

electrode are used to create the intermediate parameters of the three-dimensional electrical activity map. This step uses field theory calculations presented in greater detail below. The components which are created in this  
5 step ( $\Phi_m$ ) are stored in a digital file for later use in following steps.

At the next stage the question is asked whether the reference catheter 16 is in a calibrating position. In the calibrating position, the reference catheter 16  
10 projects directly out of the array catheter 20 establishing a length from the electrode array 19 which is a known distance from the wall 18 of the heart chamber. This calibration position may be confirmed using fluoroscopy. If the catheter is not in position  
15 then the process moves to step 45, 46 or 47.

If the reference catheter 16 is in the calibrating position then in step 44 the exact position of the reference catheter 16 is determined using the distance and orientation data from step 41. The available  
20 information includes position in space of the reference catheter 16 on the chamber wall 18 and the intermediate electrical activity map parameters of the three-dimensional map. Using these two sets of information the expected electrical activity at the reference  
25 catheter surface electrode site 24 is determined. The actual potential at this site 24 is measured from the reference catheter by the A to D converter in the voltage acquisition apparatus 30. Finally, a scale factor is adjusted which modifies the map calculations  
30 to achieve calibrated results. This adjustment factor is used in all subsequent calculations of electrical activity.

At step 47 the system polls the user to display a three-dimensional map. If such a map is desired then a  
35 method of displaying the electrical activity is first determined. Second an area, or volume is defined for which the electrical activity is to be viewed. Third a

level of resolution is defined for this view of the electrical activity. Finally the electrical activity at all of the points defined by the display option, volume and resolution are computed using the field theory  
5 calculations and the adjustment factor mentioned above. These calculated values are then used to display the data on computer 34.

Figure 7 is a representative display 71 of the output of process 47. In the preferred presentation the  
10 heart is displayed as a wire grid 36. The iso-potential map for example is overlaid on the wire grid 36 and several iso-potential lines such as iso-potential or isochrone line 38 are shown on the drawing. Typically the color of the wire grid 36 and the iso-potential or  
15 isochrone lines will be different to aid interpretation. The potentials may preferably be presented by a continuously filled color-scale rather than iso-potential or isochrone lines. The tightly closed iso-potential or isochrone line 39 may arise from an ectopic  
20 focus present at this location in the heart. In the representative display 71 of process 47 the mapping catheter assembly will not be shown.

In step 45 a subthreshold pulse is supplied to the surface electrode 24 of the reference catheter 16 by the  
25 signal generator 32. In step 54 the voltages are measured at all of the electrode sites on the electrode array 19 by the voltage acquisition apparatus 30. One problem in locating the position of the subthreshold pulse is that other electrical activity may render it  
30 difficult to detect. To counteract this problem step 55 starts by subtracting the electrical activity which was just measured in step 44 from the measurements in step 54. The location of the tip of the reference catheter 16 (i.e. surface electrode 24), is found by first  
35 performing the same field theory calculations of step 45 on this derived electrode data. Next, four positions in space are defined which are positioned near the heart



chamber walls. The potentials at these sites are calculated using the three-dimensional electrical activity map. These potentials are then used to triangulate, and thus determine, the position of the  
5 subthreshold pulse at the surface electrode 24 of the reference catheter 16. If more accurate localization is desired then four more points which are much closer to the surface electrode 24 can be defined and the triangulation can be performed again. This procedure  
10 for locating the tip of the reference catheter 16 can be performed whether the surface electrode 24 is touching the surface or is located in the blood volume and is not in contact with the endocardial surface.

At step 48 the reference catheter's position in  
15 space can be displayed by superimposing it on the map of electrical activity created in step 47. An example of such a display 71 is presented in Figure 7.

When step 46 is reached the surface electrode 24 is in a known position on the endocardial surface 18 of the  
20 heart chamber which is proper for determining the electrical activity of the tissue at that site. If the intramural or subsurface extension 100 which preferentially extends from the tip of the reference catheter 102 is not inserted into the tissue then the  
25 user of the system extends the subsurface electrode 26 into the wall 18. The potentials from the surface electrode 24 and from the intramural subsurface 26 electrode are measured by voltage acquisition apparatus 30. Next a line 21 along the heart chamber wall which  
30 has the surface electrode 24 at its center is defined by the user of the system. The three-dimensional map parameters from step 43 are then used to compute a number of points along this line including the site of the reference catheter surface electrode 24. These  
35 calculations are adjusted to conform to the measured value at the reference catheter surface electrode 24. Next a slice of tissue is defined and bounded by this

line 21 (Figure 7) and the location of the intramural subsurface electrode 26 (Figure 11) and computed positions such as 23 and 25. Subsequently a two-dimensional map 27 of the electrical activity of this slice of tissue is computed using the center of gravity calculations detailed below in the section on algorithm descriptions. Points outside of the boundary of the slice cannot be computed accurately. In step 49 this map 27 of electrical activity within the two-dimensional slice is displayed as illustrated in Figure 11. In this instance the iso-potential line 17 indicates the location within the wall 18 of the ectopic focus.

#### Description of the Preferred Computing Algorithms

Two different algorithms are suitable for implementing different stages of the present invention.

The algorithm used to derive the map of the electrical activity of the heart chamber employs electrostatic volume-conductor field theory to derive a high resolution map of the chamber volume. The second algorithm is able to estimate intramural electrical activity by interpolating between points on the endocardial surface and an intramural measurement using center of gravity calculations.

In use, the preliminary process steps identify the position of the electrode array 19 consequently the field theory algorithm can be initialized with both contact and non-contact type data. This is one difference from the traditional prior art techniques which require either contact or non-contact for accurate results, but cannot accommodate both. This also permits the system to discern the difference between small regions of electrical activity close to the electrode array 19 from large regions of electrical activity further away from the electrode array 19.

In the first algorithm, from electrostatic volume-conductor field theory it follows that all the

electrodes within the solid angle view of every locus of electrical activity on the endocardial surface are integrated together to reconstruct the electrical activity at any given locus throughout the entire volume and upon the endocardium. Thus as best shown in Figure 7 the signals from the electrode array 19 on the catheter 20 produce a continuous map of the whole endocardium. This is another difference between the present method and the traditional prior art approach which use the electrode with the lowest potential as the indicator of cardiac abnormality. By using the complete information in the algorithm, the resolution of the map shown in Figure 7 is improved by at least a factor of ten over prior methods. Other improvements include: the ability to find the optimal global minimum instead of sub-optimal local minima; the elimination of blind spots between electrodes; the ability to detect abnormalities caused by multiple ectopic foci; the ability to distinguish between a localized focus of electrical activity at the endocardial surface and a distributed path of electrical activity in the more distant myocardium; and the ability to detect other types of electrical abnormalities including detection of ischemic or infarcted tissue.

The algorithm for creating the 3D map of the cardiac volume takes advantage of the fact that myocardial electrical activity instantaneously creates potential fields by electrotonic conduction. Since action potentials propagate several orders of magnitude slower than the speed of electrotonic conduction, the potential field is quasi-static. Since there are no significant charge sources in the blood volume, Laplace's Equation for potential completely describes the potential field in the blood volume:

$$\nabla^2 \phi = 0$$

LaPlace's equation can be solved numerically or analytically. Such numerical techniques include boundary element analysis and other iterative  
 5 approaches comprised of estimating sums of nonlinear coefficients.

Specific analytical approaches can be developed based on the shape of the probe (i.e. spherical, prolate  
 10 spherical or cylindrical). From electrostatic field theory, the general spherical harmonic series solution for potential is:

$$\phi(r, \theta, \varphi) = \sum_{l=0}^{\infty} \sum_{m=-l}^l \{ A_l r^l + B_l r^{-(l+1)} \} \phi_{lm} Y_{lm}(\theta, \varphi)$$

In spherical harmonics,  $Y_{lm}(\theta, \varphi)$  is the spherical  
 15 harmonic series made up of Legendre Polynomials.  $\phi_{lm}$  is the  $lm^{\text{th}}$  component of potential and is defined as:

$$\phi_{lm} = \int V(\theta, \varphi) Y_{lm}(\theta, \varphi) d\Omega$$

where  $V(\theta, \varphi)$  is the measured potential over the probe radius  $R$  and  $d\Omega$  is the differential solid angle and, in spherical coordinates, is defined as:

$$d\Omega = \sin\theta d\theta d\varphi$$

During the first step in the algorithmic determination of the 3D map of the electrical activity each  $\Phi_{lm}$  component is determined by integrating the potential at a given point with the spherical harmonic at that point with respect to the solid angle element subtended from the origin to that point. This is an important aspect of the 3D map; its accuracy in creating the 3D map is increased with increased numbers of electrodes in the array and with increased size of the spherical array. In practice it is necessary to compute the  $\Phi_{lm}$  components with the subscript  $l$  set to 4 or greater. These  $\Phi_{lm}$  components are stored in an  $l$  by  $m$  array for later determination of potentials anywhere in the volume within the endocardial walls.

The bracketed expression of equation 1 (in terms of  $A_l$ ,  $B_l$ , and  $r$ ) simply contains the extrapolation coefficients that weight the measured probe components to obtain the potential components anywhere in the cavity. Once again, the weighted components are summed to obtain the actual potentials. Given that the potential is known on the probe boundary, and given that the probe boundary is non-conductive, we can determine the coefficients  $A_l$  and  $B_l$ , yielding the following final solution for potential at any point within the boundaries of the cavity, using a spherical probe of radius  $R$ :

$$\phi(r, \theta, \varphi) = \sum_{l=0}^{\infty} \sum_{m=-l}^l \left[ \left( \frac{l+1}{2l+1} \right) \left( \frac{r}{R} \right)^l + \left( \frac{l}{2l+1} \right) \left( \frac{r}{R} \right)^{-l-1} \right] \Phi_{lm} Y_{lm}(\theta, \varphi)$$

On exemplary method for evaluating the integral for  $\Phi_{lm}$  is the technique of Filon integration with an estimating sum, discretized by  $p$  latitudinal rows and  $q$  longitudinal columns of electrodes on the spherical probe.

$$\phi_{lm} = \frac{4\pi}{pq} \sum_{i=1}^p \sum_{j=1}^q V(\theta_i, \varphi_j) Y_{lm}(\theta_i, \varphi_j)$$

Note that p times q equals the total number of electrodes on the spherical probe array. The angle  $\theta$  ranges from zero to  $\pi$  radians and  $\varphi$  ranges from zero to  $2\pi$  radians.

5        At this point the determination of the geometry of the endocardial walls enters into the algorithm. The potential of each point on the endocardial wall can now be computed by defining them as  $r$ ,  $\theta$ , and  $\varphi$ . During the activation sequence the graphical representation of the electrical activity on the endocardial surface can be  
10        slowed down by 30 to 40 times to present a picture of the ventricular cavity within a time frame useful for human viewing.

15        A geometric description of the heart structure is required in order for the algorithm to account for the inherent effect of spatial averaging within the medium (blood). Spatial averaging is a function of both the conductive nature of the medium as well as the physical dimensions of the medium.

20        Given the above computed three-dimensional endocardial potential map, the intramural activation map of Figure 11 is estimated by interpolating between the accurately computed endocardial potentials at locations 23 and 25 (Figure 7), and actual recorded endocardial  
25        value at the surface electrode 24 and an actual recorded intramural value at the subsurface electrode 26 site. This first-order estimation of the myocardial activation map assumes that the medium is homogenous and that the medium contains no charge sources. This myocardial  
30        activation estimation is limited by the fact that the myocardial medium is not homogeneous and that there are charge sources contained within the myocardial medium. If more than one intramural point was sampled the

underlying map of intramural electrical activity could be improved by interpolating between the endocardial surface values and all the sample intramural values. The center-of-gravity calculations can be summarized by  
5 the equation:

$$V(\bar{r}_x) = \frac{\sum_{i=1}^n V_i (|\bar{r}_x - \bar{r}_i|^{-k})}{\sum_{i=1}^n |\bar{r}_x - \bar{r}_i|^{-k}}$$

where,  $V(x)$  represents the potential at any desired point defined by the three-dimensional vector  $x$  and,  $V_i$  represents each of  $n$  known potentials at a point defined  
10 by the three-dimensional vector  $i$ , and,  $k$  is an exponent that matches the physical behavior of the tissue medium.

From the foregoing description, it will be apparent that the method for determining a continuous map of the electrical activity of the endocardial surface of the  
15 present invention has a number of advantages, some of which have been described above and others of which are inherent in the invention. Also modifications can be made to the mapping probe without departing from the teachings of the present invention. Accordingly the  
20 scope of the invention is only to be limited as necessitated by the accompanying claims.

We claim:

1. A method of mapping a volumetric electrical potential distribution of a heart chamber arising from electrical activation in a myocardium comprising the steps of:
  - a) positioning an electrode array within the endocardial cavity;
  - b) positioning a reference electrode at the interior surface of said heart chamber at a known distance from said array 19, said reference electrode 24 and said array 19 together defining a reference position;
  - c) measuring volume and shape of said heart chamber, and generating volume measurement data from the volume and shape measurements;
  - d) computing the position of said array, from said volume measurement, and from said endocardial reference position, and generating array position measurement data from the electrical potential measurements;
  - e) measuring electrical potentials on said array, and generating electrical potential measurement data;
  - f) computing the three-dimensional volumetric electrical field distribution of said heart chamber volume from a solution to Laplace's equation containing said electrical potential measurements, and said array position measurement data;
  - g) displaying said volumetric electrical field distribution.
  
2. A method of mapping a two-dimensional electrical potential distribution within a wall of a heart chamber arising from electrical activation in a myocardium comprising the steps of:
  - a) positioning an electrode array 19 within the endocardial cavity;
  - b) positioning a reference electrode 24 at the interior surface of said heart chamber at a known distance from said array 19, said reference electrode 24



- and said array 19 together defining an endocardial reference position;
- c) measuring volume and shape of said heart chamber, and generating volume measurement data from the volume and shape measurements;
  - d) computing the position of said array, from said volume measurement, and from said endocardial reference position, generating array position measurement data;
  - e) measuring the electrical potentials on said array and, generating electrical potential measurement data from the electrical potential measurements;
  - f) computing a three-dimensional volumetric electrical field distribution of said heart chamber volume from a spherical harmonic series expression containing said electrical potential measurement data, and said array position measurement data;
  - g) defining a set of computed potential points on the wall of said heart chamber;
  - h) inserting an intramural electrode into said wall defining a subsurface electrode site and, generating a subsurface voltage measurement, from said subsurface electrode site;
  - i) computing a two-dimensional potential distribution from a center of gravity calculation from said computed potential points from step g) and from said subsurface voltage measurement from step h), and generating two-dimensional map data from the two dimensional potential distribution;
  - j) displaying a two-dimensional potential distribution map from said two-dimensional map data.

3. The method of claim 1 or claim 2 wherein said electrode array has more than twenty electrodes.

4. The method of claim 1 or claim 2 wherein said step c) comprises:

- c1) generating a sequence of impedance

plethysmography signals on said array;

c2) measuring a resultant sequence of plethysmographic signals characterizing said heart volume; and

c3) generating said volume measurement data from step c2.

5. A mapping catheter for use in mapping cardiac electrical potentials of a patient's heart comprising:  
a set of electrodes;

first positioning means coupled to said set of electrodes for spacing a portion of said set of electrodes, defined as a first subset of electrodes, apart from and not in contact with a surface of said patient's heart;

second positioning means coupled to said set of electrodes for placing a second predetermined subset of said set of electrodes into contact with a surface of said patient's heart.

6. The apparatus of claim 1 further comprising:

third positioning means coupled to said set of electrodes for placing a third predetermined subset of said electrodes into a position beneath a surface of said patient's heart.

7. The apparatus of claim 1 wherein said set of electrodes exceeds twelve electrodes.

8. The apparatus of claim 1 wherein said first subset of electrodes exceeds one.

9. The apparatus of claim 1 wherein said second subset is at least one.

10. The apparatus of claim 1 wherein said first positioning means is substantially spherical in shape.

11. The apparatus of claim 1 wherein said second positioning means has a substantially cylindrical shape.

12. A catheter assembly 10 for mapping the interior of a patient's heart comprising:

a first set of electrode sites defining a first electrode array;

said electrode array positioned within said patient's heart with a substantial number of said electrodes not in contact with said heart;

a second set of electrode sites located in contact with said patient's heart.

13. A catheter assembly for mapping the electrical potential of the interior of a heart chamber of a patient's heart comprising:

a flexible lead body, connected to a deformable lead body, said flexible lead body and said deformable lead body having a lumen;

said deformable lead body deformable to a first collapsed position wherein said deformable lead body has a substantially cylindrical shape and, said deformable lead body deformable to a second expanded position wherein said deformable lead body has a substantially spherical shape;

an electrode array having a plurality of electrode sites located proximate said deformable lead body, wherein said electrode sites form a spherical array of electrode sites when said deformable lead body is in said second expanded position;

a reference catheter having a tip electrode assembly;

said reference catheter being located in said lumen and supported for relative motion with respect to said electrode array such that said tip electrode assembly may be placed into contact with said patient's heart when said array is in said heart chamber.

14. The catheter assembly of claim 1 further comprising:

means for excluding blood from the interior of said deformable lead body when said deformable lead body is in said second expanded position.

15. The catheter assembly of claim 8 wherein said flexible lead body comprises a braid of insulated wires incorporated into a polymeric sheath.

16. A method of forming a catheter comprising the steps of:

- a) forming a collection of insulated wires each having an interior conductor, and each having an exterior insulation coating;
- b) braiding the wires formed in step a) forming braided structure having a central lumen;
- c) incorporating the braided structure in a polymeric material forming a flexible lead body;
- d) removing said polymeric material from a portion of said flexible lead body exposing said braid of insulated wires forming a deformable lead body;
- f) removing insulation from selected locations on selected insulated wires to form electrode sites on said deformable lead body.

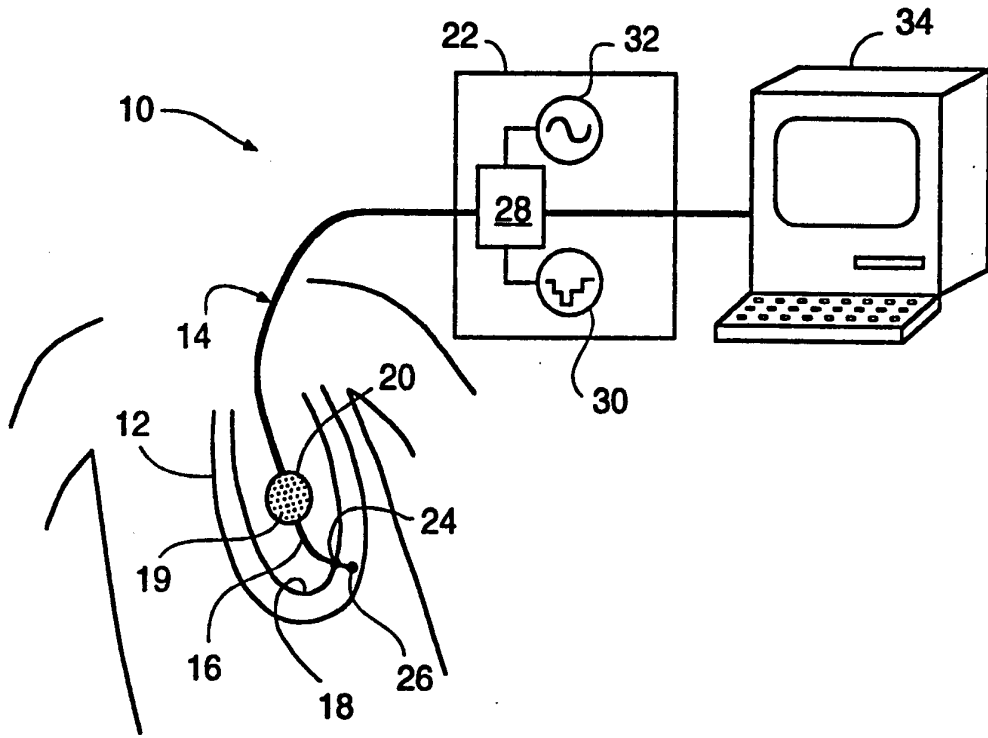

FIG. 1

**SUBSTITUTE SHEET**

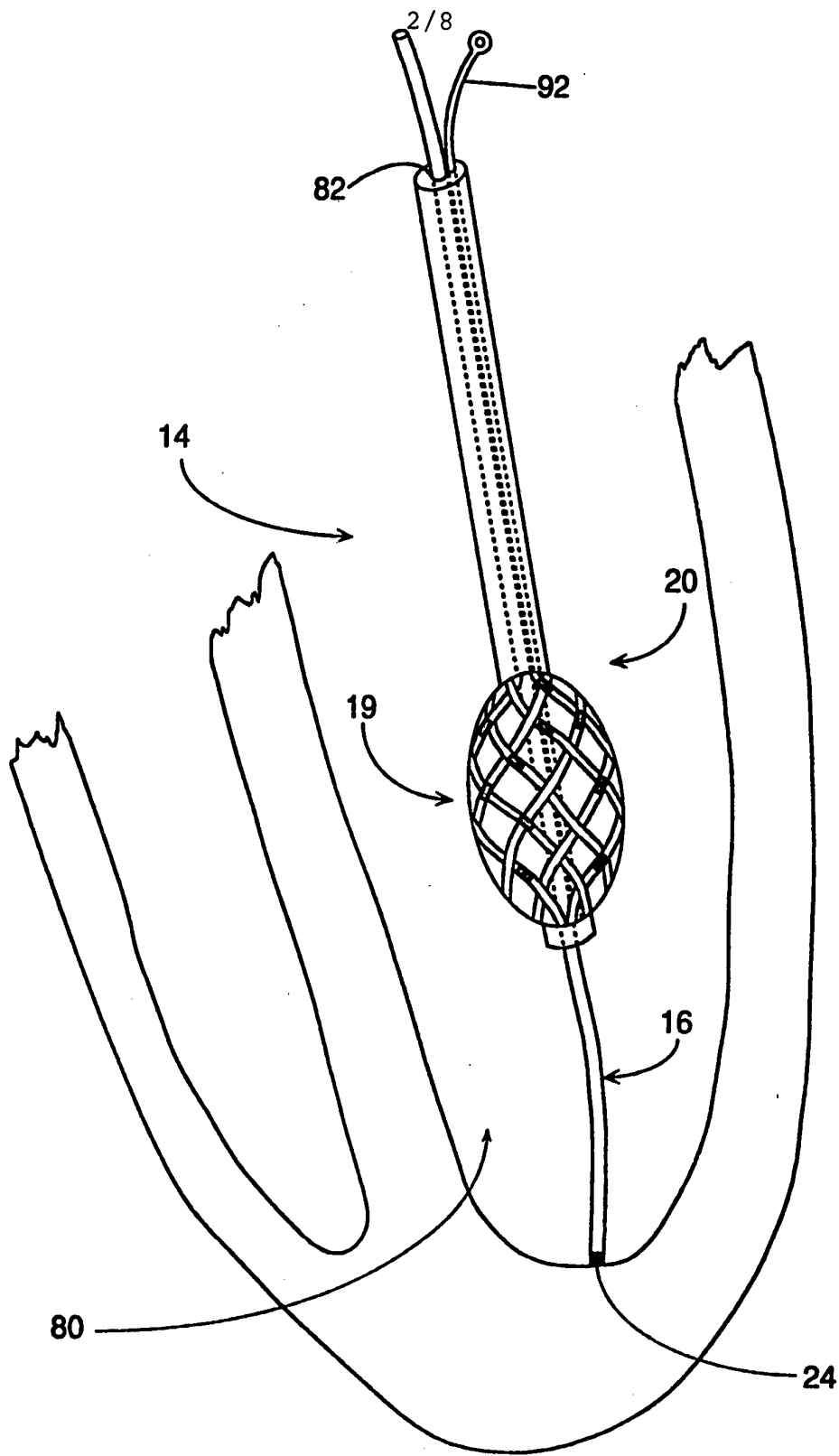

FIG. 2  
SUBSTITUTE SHEET

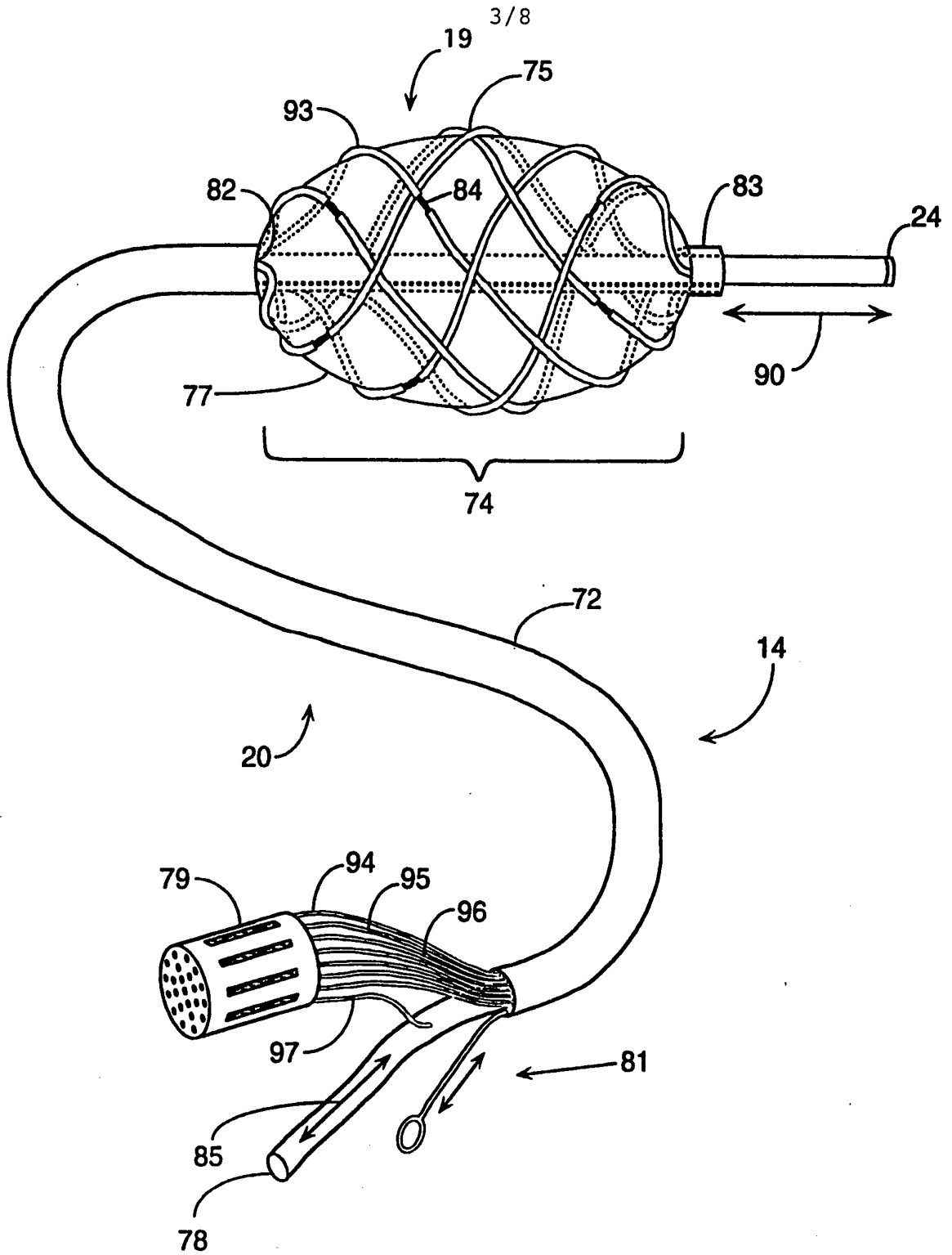

FIG. 3

**SUBSTITUTE SHEET**

4/8

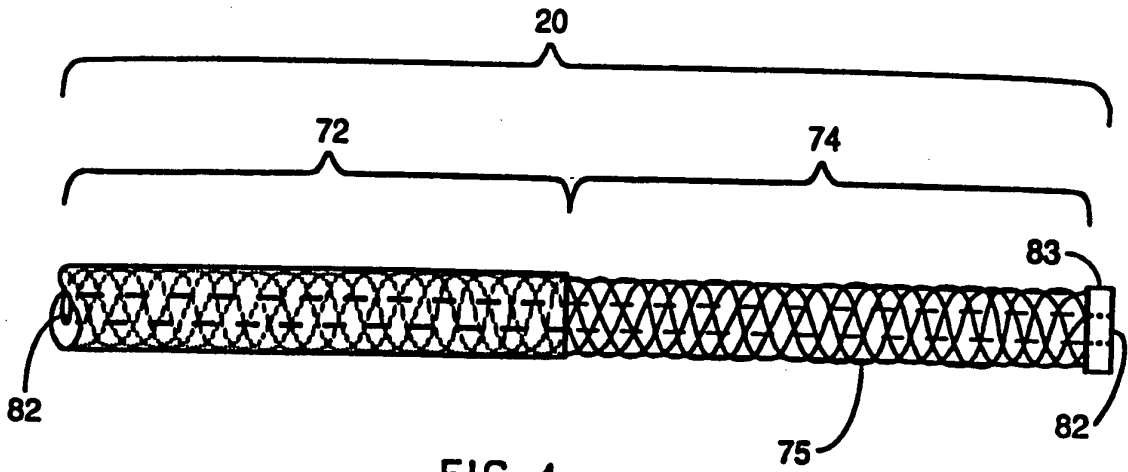

FIG. 4

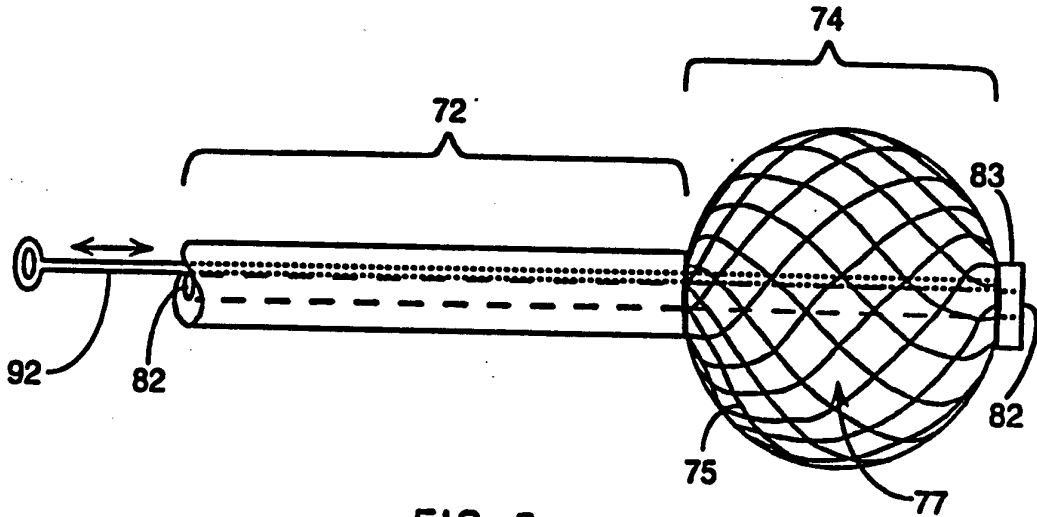

FIG. 5

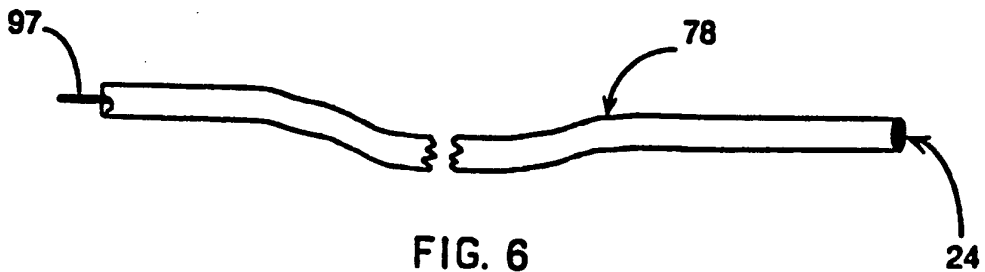

FIG. 6

SUBSTITUTE SHEET



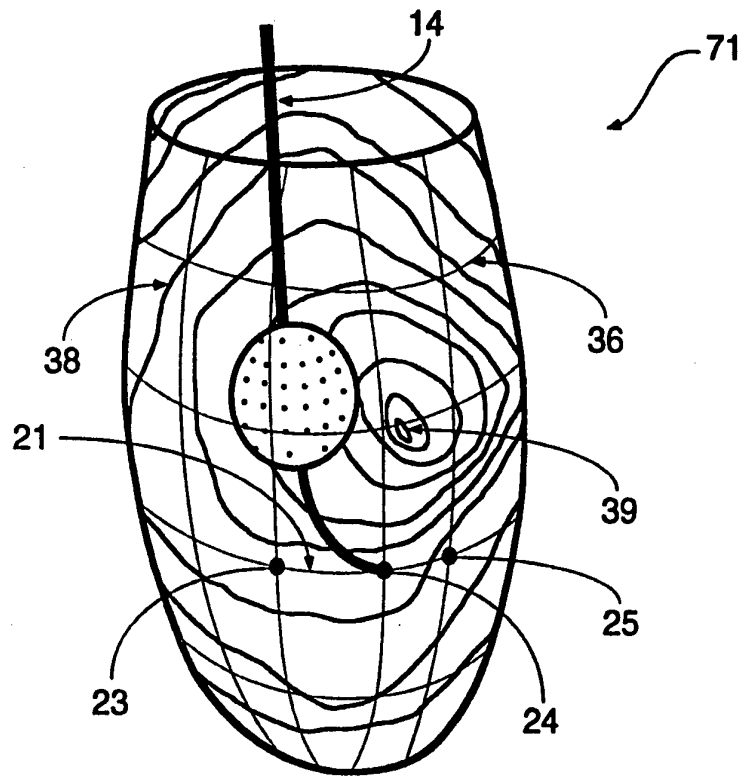

FIG. 7

**SUBSTITUTE SHEET**

6/8

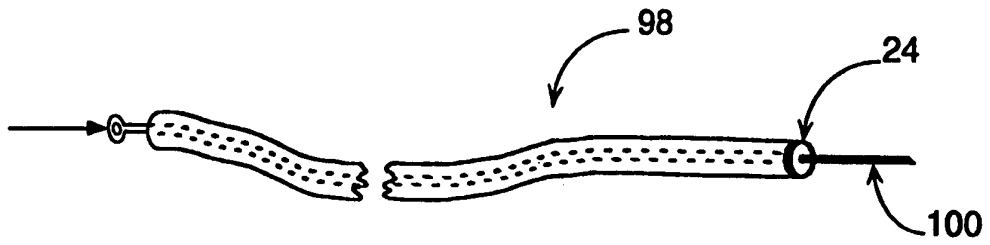

FIG. 8

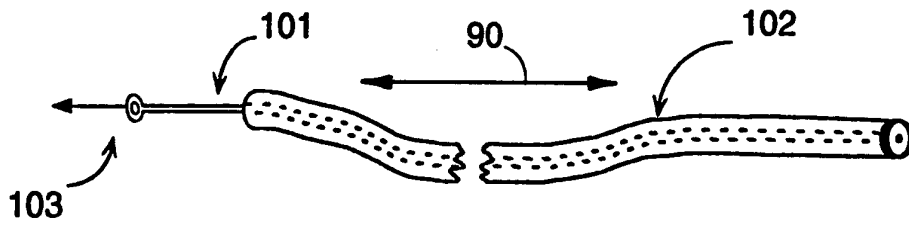

FIG. 9

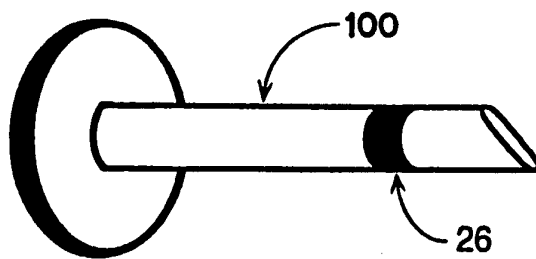

FIG. 10

**SUBSTITUTE SHEET**

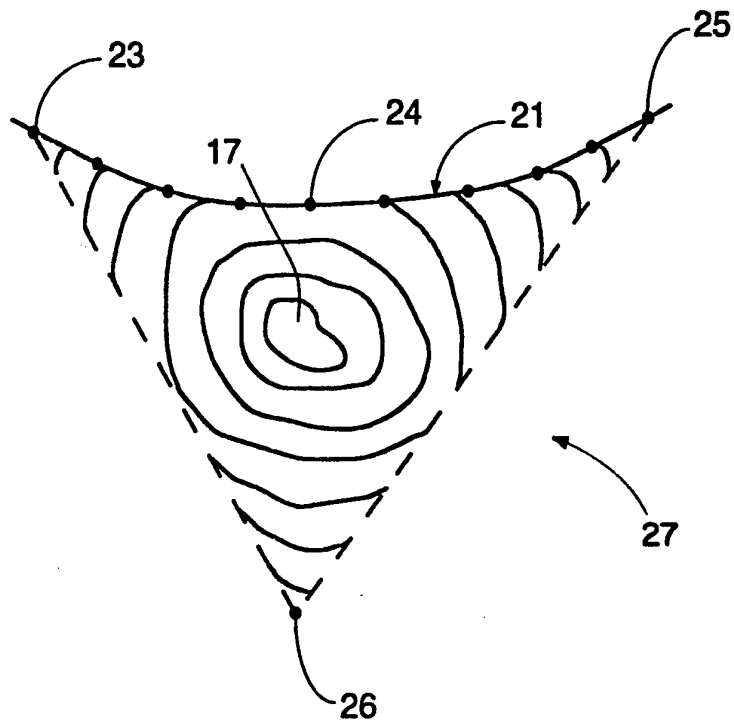
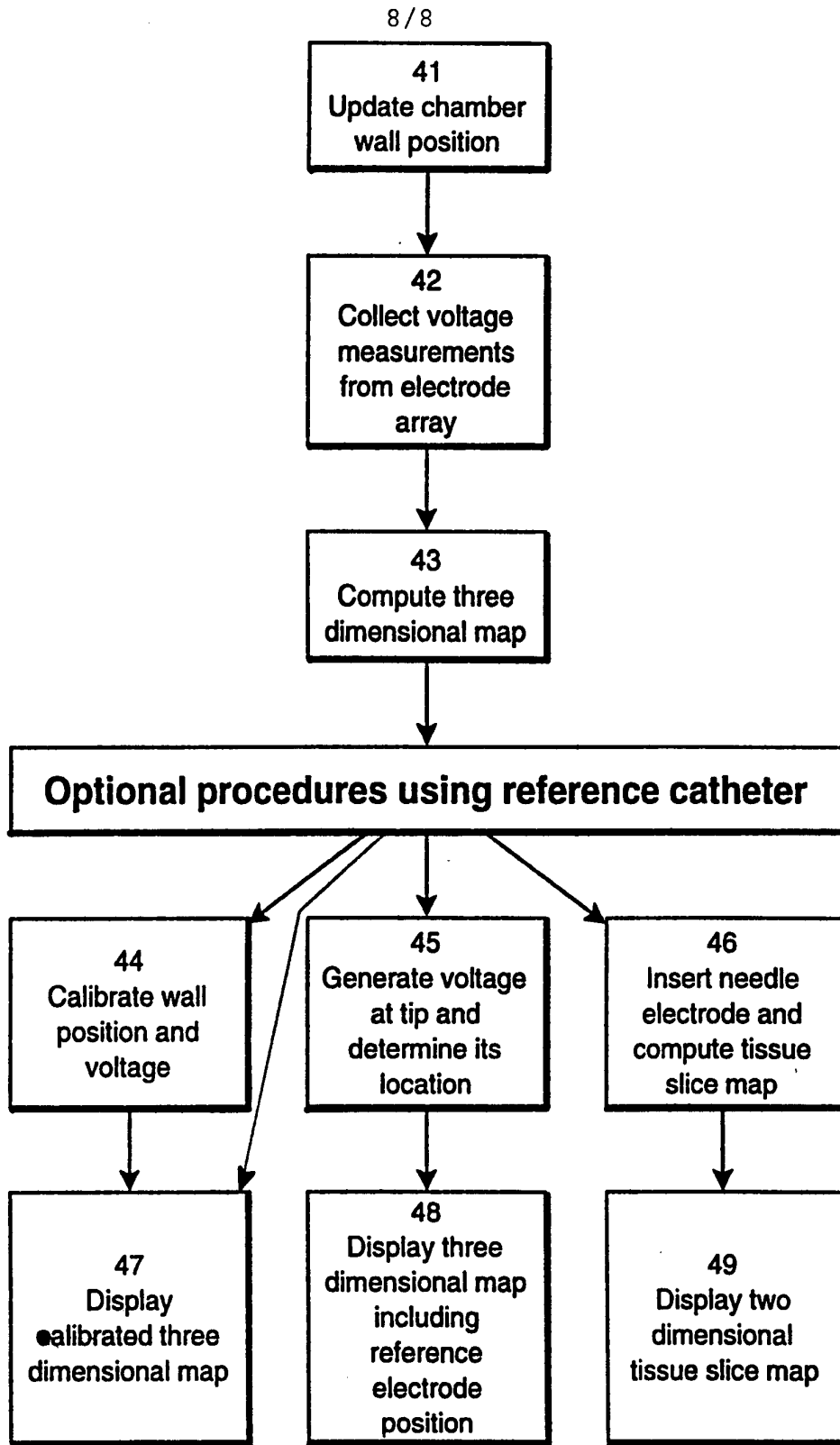

FIG. 11



**FIG. 12**

**SUBSTITUTE SHEET**

**INTERNATIONAL SEARCH REPORT**

International Application No  
**PCT/US 93/09015**

**A. CLASSIFICATION OF SUBJECT MATTER**  
IPC 5 A61B5/042 A61B5/0408

According to International Patent Classification (IPC) or to both national classification and IPC

**B. FIELDS SEARCHED**

Minimum documentation searched (classification system followed by classification symbols)  
IPC 5 A61B

Documentation searched other than minimum documentation to the extent that such documents are included in the fields searched

Electronic data base consulted during the international search (name of data base and, where practical, search terms used)

**C. DOCUMENTS CONSIDERED TO BE RELEVANT**

Category *	Citation of document, with indication, where appropriate, of the relevant passages	Relevant to claim No.
Y	US,A,4 660 571 (S.R. HESS ET AL.) 28 April 1987	1,2
A	see column 3, line 40 - line 60 see column 5, line 11 - column 6, line 39 ---	8,13,14
Y	US,A,4 911 174 (B.D. PEDERSON ET AL.) 27 March 1990	1,2
A	see column 2, line 53 - column 4, line 44 ---	4
A	US,A,4 777 955 (D.L. BRAYTON ET AL.) 18 October 1988	1-6,8,9
A	see column 4, line 20 - line 50 ---	12
A	FR,A,2 569 103 (CONSIGLIO NAZIONALE DELLE RICERCHE) 21 February 1986 see page 4, line 14 - page 6, line 29 ---	1-3,5,6, 8-10,12
	-/--	

Further documents are listed in the continuation of box C.

Patent family members are listed in annex.

\* Special categories of cited documents :

- \*A\* document defining the general state of the art which is not considered to be of particular relevance
- \*E\* earlier document but published on or after the international filing date
- \*L\* document which may throw doubts on priority claim(s) or which is cited to establish the publication date of another citation or other special reason (as specified)
- \*O\* document referring to an oral disclosure, use, exhibition or other means
- \*P\* document published prior to the international filing date but later than the priority date claimed

- \*T\* later document published after the international filing date or priority date and not in conflict with the application but cited to understand the principle or theory underlying the invention
- \*X\* document of particular relevance; the claimed invention cannot be considered novel or cannot be considered to involve an inventive step when the document is taken alone
- \*Y\* document of particular relevance; the claimed invention cannot be considered to involve an inventive step when the document is combined with one or more other such documents, such combination being obvious to a person skilled in the art.
- \* & \* document member of the same patent family

Date of the actual completion of the international search

21 January 1994

Date of mailing of the international search report

11-02-1994

Name and mailing address of the ISA

European Patent Office, P.B. 5818 Patentlaan 2  
NL - 2280 HV Rijswijk  
Tel. (+31-70) 340-2040, Tx. 31 651 epo nl,  
Fax (+31-70) 340-3016

Authorized officer

Rieb, K.D.

## INTERNATIONAL SEARCH REPORT

International Application No

PCT/US 93/09015

## C.(Continuation) DOCUMENTS CONSIDERED TO BE RELEVANT

Category *	Citation of document, with indication, where appropriate, of the relevant passages	Relevant to claim No.
A	US,A,4 699 147 (D.A. CHILSON ET AL.) 13 October 1987	1-3,5,6
A	see column 6, line 18 - column 7, line 35 ----	8,9,12
A	US,A,4 890 623 (W. COOK ET AL.) 2 January 1990	1,2,5,10
A	see column 4, line 4 - line 41 see column 5, line 32 - line 55 ----	12,14,15
A	MED. AND BIOL. ENGINEERING AND COMPUTING, vol.18, no.5, September 1980, STEVENAGE (GB) pages 617 - 624 P. MENGLER ET AL. 'Multichannel Recording of Cardiac Potentials' see page 618; figure 1 -----	1-3,5,6, 8,9

# INTERNATIONAL SEARCH REPORT

Information on patent family members

International Application No

PCT/US 93/09015

Patent document cited in search report	Publication date	Patent family member(s)	Publication date
US-A-4660571	28-04-87	NONE	
US-A-4911174	27-03-90	EP-A- 0384060	29-08-90
		JP-A- 2215442	28-08-90
US-A-4777955	18-10-88	NONE	
FR-A-2569103	21-02-86	AU-B- 564989	03-09-87
		AU-A- 4554085	20-02-86
		CA-A- 1265586	06-02-90
		DE-A- 3529063	27-02-86
		GB-A, B 2163055	19-02-86
		JP-A- 61062444	31-03-86
		US-A- 4649924	17-03-87
US-A-4699147	13-10-87	NONE	
US-A-4890623	02-01-90	NONE	