

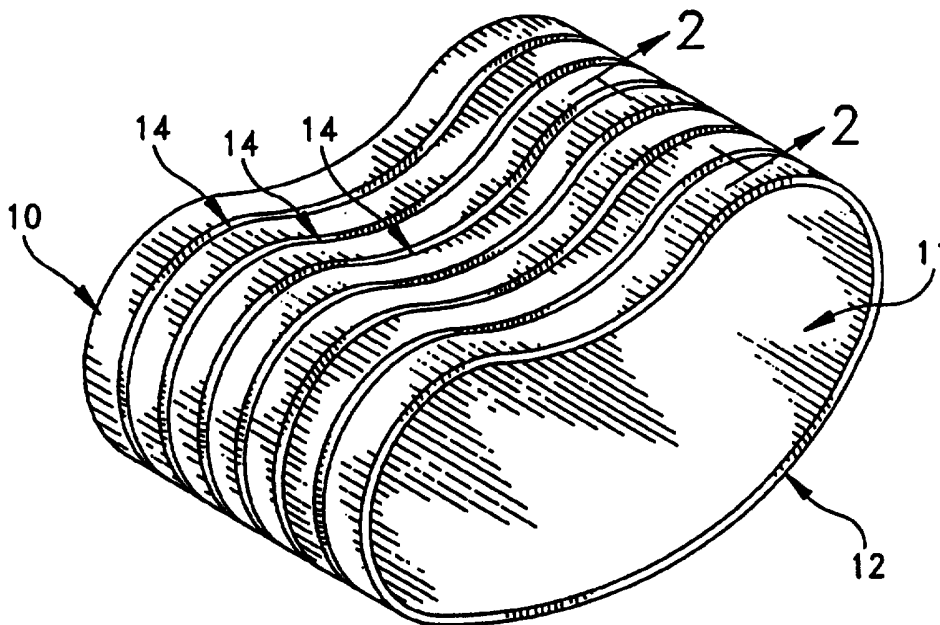

INTERNATIONAL APPLICATION PUBLISHED UNDER THE PATENT COOPERATION TREATY (PCT)

<p>(51) International Patent Classification ⁶ : D21F 3/02</p>	<p>A1</p>	<p>(11) International Publication Number: WO 96/12065 (43) International Publication Date: 25 April 1996 (25.04.96)</p>
<p>(21) International Application Number: PCT/FI95/00571 (22) International Filing Date: 17 October 1995 (17.10.95) (30) Priority Data: 08/324,742 18 October 1994 (18.10.94) US (71) Applicant (for all designated States except US): TAMFELT OY AB [FI/FI]; Yrittäjänkatu 21, FIN-33100 Tampere (FI). (72) Inventor; and (75) Inventor/Applicant (for US only): JERMO, Olli [FI/FI]; Koulukatu 15-17 D 70, FIN-33200 Tampere (FI). (74) Agent: OY KOLSTER AB; Iso Roobertinkatu 23, P.O. Box 148, FIN-00121 Helsinki (FI).</p>	<p>(81) Designated States: AL, AM, AT, AU, BB, BG, BR, BY, CA, CH, CN, CZ, DE, DK, EE, ES, FI, GB, GE, HU, IS, JP, KE, KG, KP, KR, KZ, LK, LR, LT, LU, LV, MD, MG, MK, MN, MW, MX, NO, NZ, PL, PT, RO, RU, SD, SE, SG, SI, SK, TJ, TM, TT, UA, UG, US, UZ, VN, European patent (AT, BE, CH, DE, DK, ES, FR, GB, GR, IE, IT, LU, MC, NL, PT, SE), OAPI patent (BF, BJ, CF, CG, CI, CM, GA, GN, ML, MR, NE, SN, TD, TG), ARIPO patent (KE, MW, SD, SZ, UG).</p> <p>Published <i>With international search report. Before the expiration of the time limit for amending the claims and to be republished in the event of the receipt of amendments.</i></p>	

(54) Title: GROOVE CONFIGURATION FOR A PRESS BELT



(57) Abstract

The grooves of a grooved press belt are formed with an improved configuration which reduces groove closure under pressure and which reduces cracking and tearing of the belt. The improved groove configuration consists of a curved bottom (20) and two upwardly diverging side walls (22). In a first embodiment the bottom wall is semi-circular and has a diameter (D) which is equal to about one half of the width (W) of the groove opening. The upwardly diverging side walls (22) preferably include radiused upper edges (24). The side walls (22) preferably have an angle of divergence between about five degrees and about fifteen degrees from a vertical plane. In a second embodiment, the bottom of the groove is substantially flat, and the bottom corners are radiused to provide a smooth transition between the flat bottom and the upwardly diverging side walls.

FOR THE PURPOSES OF INFORMATION ONLY

Codes used to identify States party to the PCT on the front pages of pamphlets publishing international applications under the PCT.

AT	Austria	GB	United Kingdom	MR	Mauritania
AU	Australia	GE	Georgia	MW	Malawi
BB	Barbados	GN	Guinea	NE	Niger
BE	Belgium	GR	Greece	NL	Netherlands
BF	Burkina Faso	HU	Hungary	NO	Norway
BG	Bulgaria	IE	Ireland	NZ	New Zealand
BJ	Benin	IT	Italy	PL	Poland
BR	Brazil	JP	Japan	PT	Portugal
BY	Belarus	KE	Kenya	RO	Romania
CA	Canada	KG	Kyrgystan	RU	Russian Federation
CF	Central African Republic	KP	Democratic People's Republic of Korea	SD	Sudan
CG	Congo	KR	Republic of Korea	SE	Sweden
CH	Switzerland	KZ	Kazakhstan	SI	Slovenia
CI	Côte d'Ivoire	LI	Liechtenstein	SK	Slovakia
CM	Cameroon	LU	Luxembourg	SN	Senegal
CN	China	LV	Latvia	TD	Chad
CS	Czechoslovakia	MC	Monaco	TG	Togo
CZ	Czech Republic	MD	Republic of Moldova	TJ	Tajikistan
DE	Germany	MG	Madagascar	TT	Trinidad and Tobago
DK	Denmark	ML	Mali	UA	Ukraine
ES	Spain	MN	Mongolia	US	United States of America
FI	Finland			UZ	Uzbekistan
FR	France			VN	Viet Nam
GA	Gabon				

Groove configuration for a press belt**Background and Summary of the Invention:**

The instant invention relates to grooved press belts for use in paper making machinery, and other like machinery, and more particularly to an improved groove configuration for such press belts.

Press belts are used in various press devices, such as shoe-type presses, as used in paper making machines and calendars, to transport a continuous sheet through a press nip. The prior art press belts typically comprise a polyurethane or rubber material having a reinforcing fiber weave imbedded therein. In the paper making art, it is well known to provide grooves in the outer surface of a press belt in order to provide a channel to carry water away from the sheet as it is being pressed. In this connection, grooves are usually formed with a rectangular cross-section. However, there are two significant problems with conventional rectangular groove configurations. The first problem is that rectangular shaped grooves have a natural tendency to close under pressure of the nip. The pressure of the nip deforms the lands between the grooves forcing the sides of the grooves toward each other and thereby closing the groove. Several solutions have been proposed for the problem of groove closure. However, none of the proposed solutions appear to be satisfactory. U.S. Patent No. 4,880,501 discloses a groove configuration wherein the tops of the lands are formed with a concave shape. This concave formation is believed to reduce the deformation of the land. However, this type of machining is very difficult to accomplish, and furthermore it does not completely eliminate groove closure. U.S. Patent No. 4,908,103 discloses a press belt having an outer surface which is constructed of a harder material which is not

as likely to be elastically deformed. However, the use of two different elastomers leads to problems with delamination or separation of the two elastomer layers. British Patent No. GB 8818992.3 discloses a press belt wherein cross-pieces extend between the lands to provide to support the lands. However, reinforcing cross-pieces reduce the efficiency of the grooves by hindering the flow of water once in the grooves. Furthermore, the cross-pieces are difficult to machine.

The second problem associated with conventional rectangular groove configurations is the tendency for the lands to break off at their base. Cracking of the belt leads to shortened life span, increased belt replacement, and increased machine down time. In this regard, it has been found that the cumulative stress of repeatedly passing through the nip causes the lands to crack at their bottom edges. The sharp corners of the rectangular grooves create stress points in the material wherein the maximum stress often exceeds four times the stress elsewhere in the material. In order to remedy this problem, it is has been suggested to make the grooved surface of the belt from a harder elastomer. However, there is the problem of delamination, as indicated earlier. In addition, harder elastomers generally have less tolerance for repeated bending as would be required in an press belt. One solution which has been suggested is to provide the elastomer with reinforcing threads (U.S. Patent No. 4,946,731). However, when a plurality of filaments are used to reinforce the elastomer, cutting of the grooves exposes the matrix of fibers and opens paths for water to get inside the belt and cause failure. Yet another solution is to provide filaments located within the lands (GB 8818992.3). However, precise location of the filaments and machining of the grooves so that the filaments lie

within the lands is extremely difficult, leading to a high percentage of substandard belts or belt rejections.

Accordingly, among the objects of the instant invention are: the provision of a groove configuration
5 for a press belt which effectively reduces groove closure; the provision of a groove configuration which reduces cracking of the belt; and the provision of a groove configuration which is simple and inexpensive to machine.

10 The above objects are accomplished by providing a groove configuration wherein the grooves are formed with an arcuate bottom and two upwardly diverging side walls. The arcuate bottom is preferably semi-circular and has a diameter which is equal to about one half of the width
15 of the groove opening. The upwardly diverging side walls preferably include radiused upper edges which provide a smooth curved transition between the side walls and the outer surface of the press belt. Each side wall preferably has an angle of divergence between about five
20 (5) degrees and about fifteen (15) degrees from a vertical plane. In a second embodiment, the groove is formed with a substantially flat bottom and radiused corners which provide a smooth transition between the flat bottom and the upwardly diverging side walls.

25 Other objects, features and advantages of the invention shall become apparent as the description thereof proceeds when considered in connection with the accompanying illustrative drawings.

Description of the Drawings:

30 In the drawings which illustrate the best mode presently contemplated for carrying out the present invention:

35 Fig. 1 is a perspective view of a grooved press belt incorporating the groove configuration of the instant invention;

Fig. 2 is a fragmentary cross-sectional view thereof taken along line 2-2 of Fig. 1;

Fig. 3 is another fragmentary cross-sectional view showing the press belt under compression; and

5 Fig. 4 is a fragmentary cross-sectional view of a second embodiment of the groove configuration.

Description of the Preferred Embodiment:

Referring now to the drawings, a first embodiment of the press belt of the instant invention is
10 illustrated and generally indicated at 10 in Figs. 1-3. As will hereinafter be more fully described, the belt 10 includes a groove configuration which reduces groove closure under compression and which reduces cracking of the belt at the bottom corners of the grooves.

15 Press belt 10 comprises a continuous loop of elastomeric material which is formed by known belt forming techniques. Press belt 10 includes inner and outer surfaces generally indicated at 11, 12, and further includes a lengthwise spiralling groove
20 generally indicated at 14. In use, the outer grooved surface 12 of the belt 10 makes contact with a sheet 18 (Fig. 3) to be pressed. The spiral groove 14 actually forms a plurality of lengthwise grooves which are separated by lands 16. Press belts 10 are generally
25 formed with a thickness between about 3-6 mm. Groove 14 is generally 0.5 to 1.0 mm wide with the lands 16 generally 2-5 times the width of the groove 14. While groove 14 has been illustrated as extending lengthwise to the direction of belt 10, it is to be understood that
30 the direction of the groove(s) is not critical to the operation of the belt. Accordingly, grooves 14 may alternatively extend either crosswise, or at an angle to the direction of the belt. The groove 14 is formed with an arcuate bottom 20, and two upwardly diverging
35 sidewalls 22. Arcuate bottom 20 preferably has a

diameter (D) which is equal to about one half of the width (W) of the groove opening (See Fig. 2). Diverging walls 22 are preferably formed with radiused top edges 24 which provide a smooth transition between side walls 22 and outer surface 12. As illustrated in Fig. 2, each side wall 22 preferably has an angle of divergence between about five (5) degrees and about fifteen (15) degrees from a vertical plane, although both smaller and larger angles of divergence are acceptable.

Referring now to Fig. 3, press belt 10 is shown in conjunction with sheet 18 which is being pressed in a shoe type pressing device (not shown). While the side walls 22 of groove 14 still tend to deform inwardly under compression, the diverging configuration of the side walls 22 compensates for the compression. The resulting groove 14 (Fig. 3) is thus generally rectangular in shape. Curved bottom 20 of groove 14 more evenly distributes the stress of the nip compression, and therefore reduces cracking and failure of the belt 10. It has been found that the stress at the transition points between the bottom 20 and side walls 22 has been effectively reduced to about 1.1 times the normal stress on the material elsewhere in the belt. As discussed previously, the maximum stress caused by a sharp corner often exceed four times the normal stress. The life of press belt 10 is thus extended by a significant amount of time over the prior art press belts.

Referring now to Fig. 4, a second embodiment of the press belt is illustrated and generally indicated at 26. Press belt 26 includes inner and outer surfaces generally indicated at 27, 28, and lengthwise spiralling groove generally indicated at 30. Unlike press belt 10, grooves 30 are formed with a substantially flat bottom 34, upwardly diverging side walls 36, and radiused bottom corners 38 which provide a smooth transition

between the flat bottom 34 and the diverging side walls 36. The side walls 36 are preferably formed with radiused upper edges 40. Each side wall 36 preferably has an angle of divergence between about five (5) degrees and about fifteen (15) degrees from a vertical plane.

In use, the diverging side walls 36 of the grooves 30 compensate for elastic deformation of the lands 32 under compression thereby resulting in a rectangular groove. The radiused corners 38 more evenly distribute the stress of the nip compression and therefore reduce cracking and failure of the belt 26.

It can therefore be seen that the instant invention provides a unique and novel groove configuration for a press belt. The groove configuration includes rounded or radiused corners which effectively reduce structural stress at the transitions between the bottom and side walls of the groove. The outwardly diverging walls of the grooves compensate for elastic deformation of the press belt and thus provide a generally rectangular groove for carrying away water from the sheet being pressed. For these reasons, the instant invention represents a significant advancement in the art which has substantial commercial merit.

While there is shown and described herein certain specific structure embodying the invention, it will be manifest to those skilled in the art that various modifications and rearrangements of the parts may be made without departing from the spirit and scope of the underlying inventive concept and that the same is not limited to the particular forms herein shown and described except insofar as indicated by the scope of the appended claims.

Claims:

1. An elastomeric press belt having inner and outer surfaces and a plurality of upwardly opening
5 grooves in said outer surface, each of said grooves comprising a bottom and two upwardly diverging side walls.

2. In the press belt of claim 1, said bottom being arcuate in configuration.

10 3. In the press belt of claim 2, said arcuate bottom being semi-circular and having a diameter which is equal to about one half of the width of the groove opening.

15 4. In the press belt of claim 1, said upwardly diverging side walls including radiused upper edges which provide a smooth curved transition between said side walls and said outer surface of said press belt.

20 5. In the press belt of claim 1, each of said side walls having an angle of divergence between about five degrees and about fifteen degrees from a vertical plane.

25 6. An elastomeric press belt having inner and outer surfaces and a plurality of upwardly opening grooves in said outer surface, each of said grooves comprising a bottom, two upwardly diverging side walls and radiused bottom corners which provide a smooth curved transition between said bottom and said upwardly diverging sidewalls.

30 7. In the press belt of claim 6, said upwardly diverging side walls including radiused upper edges which provide a smooth curved transition between said side walls and said outer surface of said press belt.

35 8. In the press belt of claim 6, each of said side walls having an angle of divergence between about five degrees and about fifteen degrees from a vertical plane.

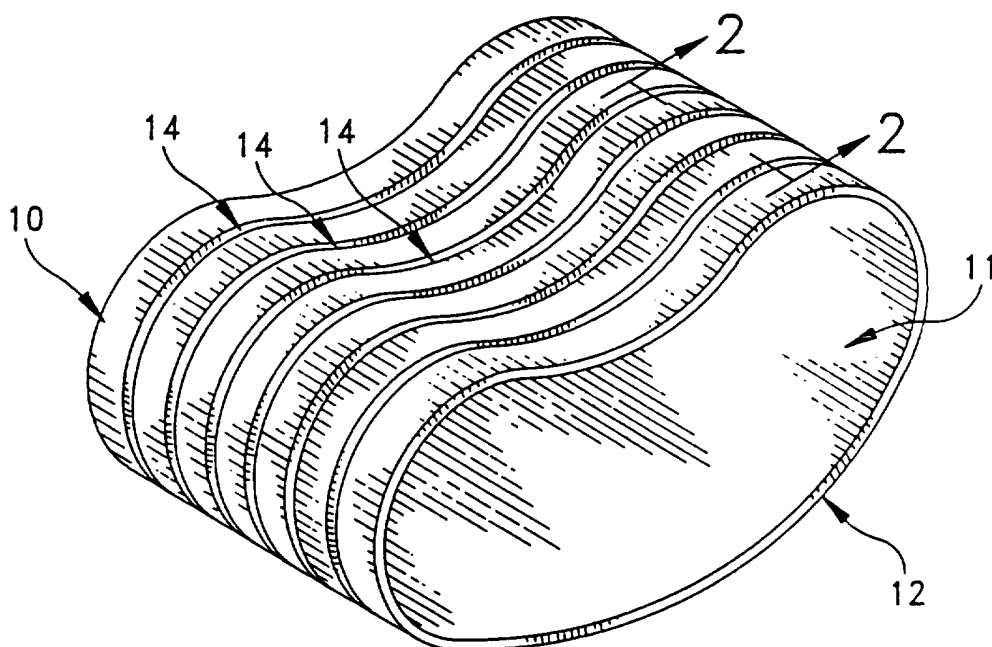

FIG. 1

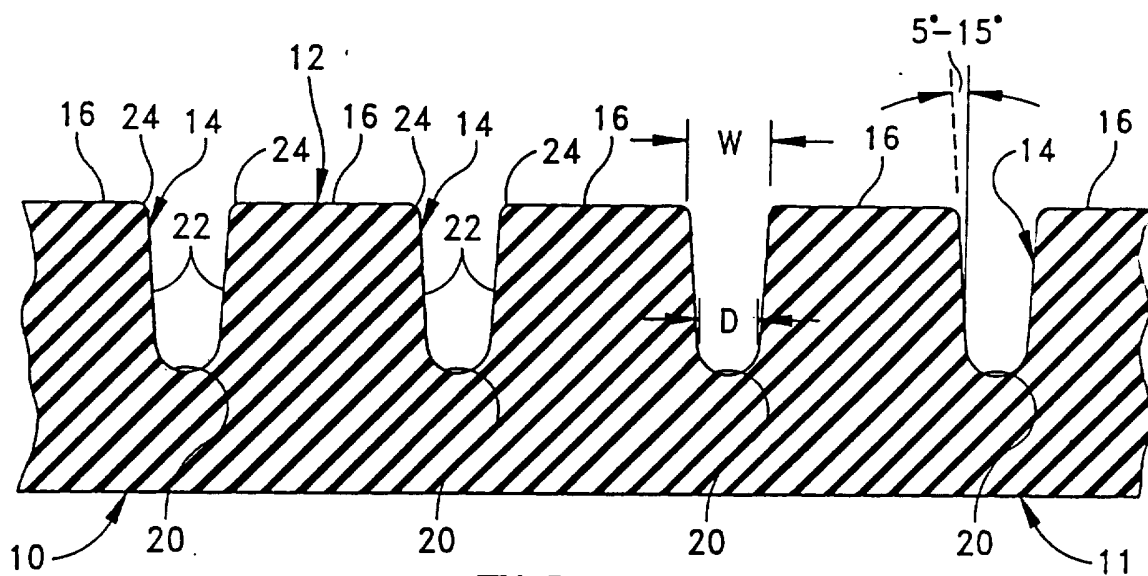
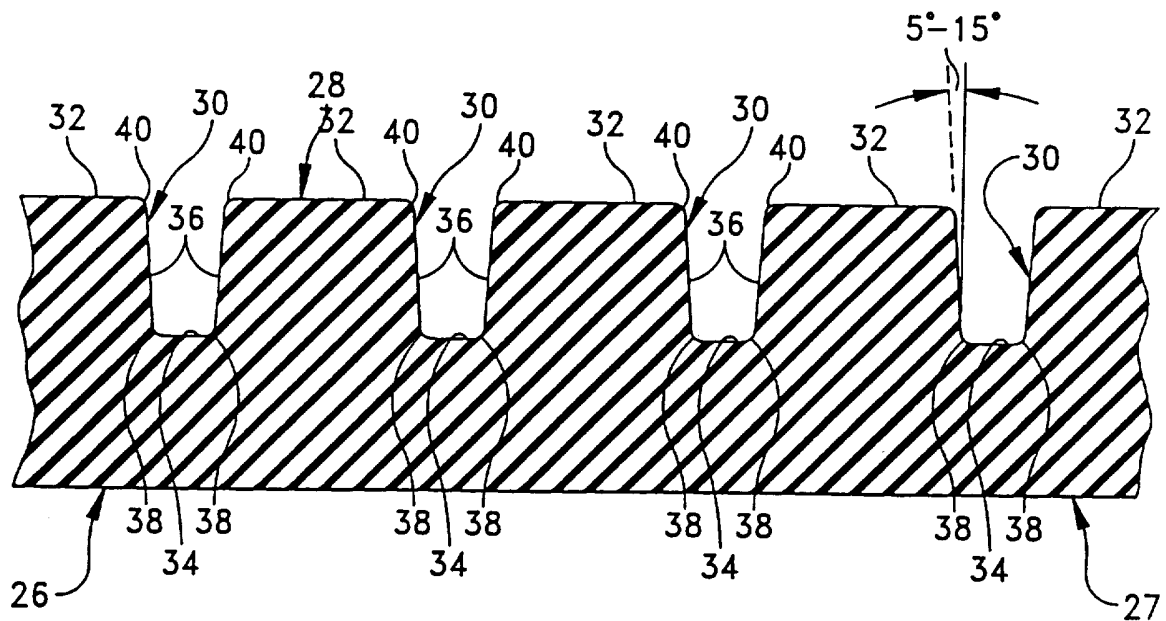
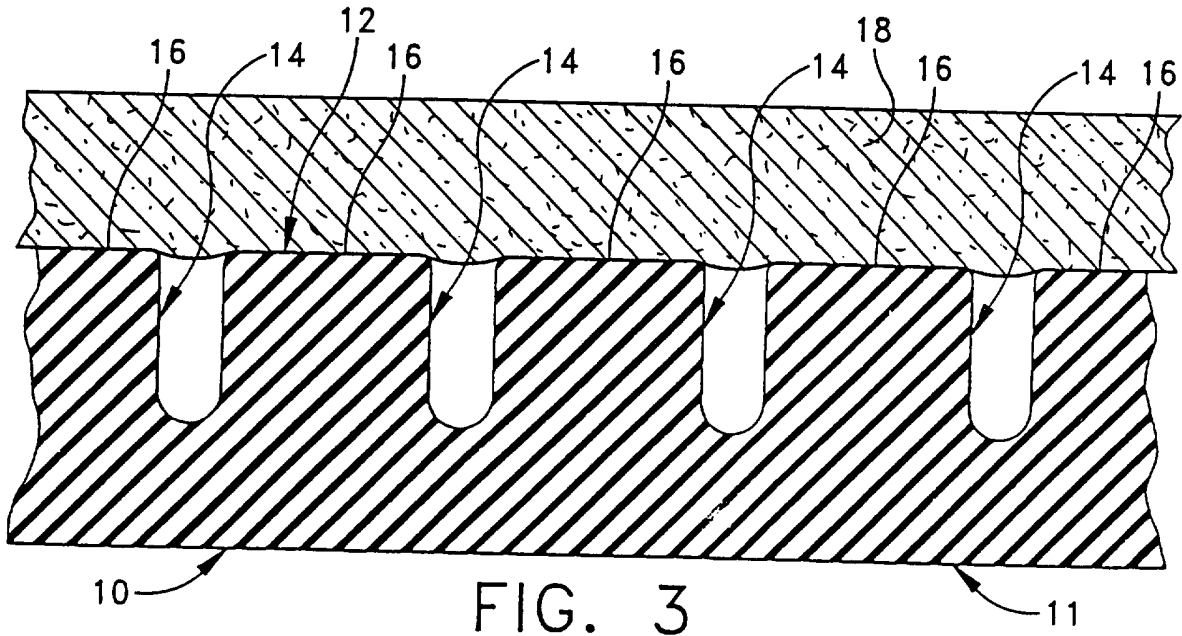

FIG. 2



INTERNATIONAL SEARCH REPORT

International application No.

PCT/FI 95/00571

A. CLASSIFICATION OF SUBJECT MATTER

IPC6: D21F 3/02

According to International Patent Classification (IPC) or to both national classification and IPC

B. FIELDS SEARCHED

Minimum documentation searched (classification system followed by classification symbols)

IPC6: D21F

Documentation searched other than minimum documentation to the extent that such documents are included in the fields searched

SE,DK,FI,NO classes as above

Electronic data base consulted during the international search (name of data base and, where practicable, search terms used)

C. DOCUMENTS CONSIDERED TO BE RELEVANT

Category*	Citation of document, with indication, where appropriate, of the relevant passages	Relevant to claim No.
A	US 4880501 A (CHRISTIAN SCHIEL), 14 November 1989 (14.11.89) --	1
A	US 4908103 A (DENNIS C. CRONIN ET AL), 13 March 1990 (13.03.90) --	1
A	US 4946731 A (WILLIAM H. DUTT), 7 August 1990 (07.08.90) -- -----	1

Further documents are listed in the continuation of Box C.

See patent family annex.

* Special categories of cited documents:

- "A" document defining the general state of the art which is not considered to be of particular relevance
- "E" earlier document but published on or after the international filing date
- "L" document which may throw doubts on priority claim(s) or which is cited to establish the publication date of another citation or other special reason (as specified)
- "O" document referring to an oral disclosure, use, exhibition or other means
- "P" document published prior to the international filing date but later than the priority date claimed

"T" later document published after the international filing date or priority date and not in conflict with the application but cited to understand the principle or theory underlying the invention

"X" document of particular relevance: the claimed invention cannot be considered novel or cannot be considered to involve an inventive step when the document is taken alone

"Y" document of particular relevance: the claimed invention cannot be considered to involve an inventive step when the document is combined with one or more other such documents, such combination being obvious to a person skilled in the art

"&" document member of the same patent family

Date of the actual completion of the international search

12 February 1996

Date of mailing of the international search report

13-02-1996

Name and mailing address of the ISA/
Swedish Patent Office
Box 5055, S-102 42 STOCKHOLM
Facsimile No. +46 8 666 02 86

Authorized officer

Olov Jensen
Telephone No. +46 8 782 25 00

INTERNATIONAL SEARCH REPORT

Information on patent family members

05/01/96

International application No.

PCT/FI 95/00571

Patent document cited in search report	Publication date	Patent family member(s)	Publication date
US-A- 4880501	14/11/89	AT-B- 392100	25/01/91
		DE-C- 3727563	09/02/89
		GB-A,B- 2208879	19/04/89
		JP-A- 1061591	08/03/89
		JP-C- 1673692	26/06/92
		JP-B- 3029919	25/04/91
		SE-B,C- 470317	17/01/94
		SE-A- 8802510	20/02/89
		US-A- 4908103	13/03/90
AU-A- 4961885	24/04/87		
CA-A- 1296938	10/03/92		
EP-A,B- 0239570	07/10/87		
SE-T3- 0239570			
US-A- 4978428	18/12/90		
WO-A- 8702080	09/04/87		
US-A- 4946731	07/08/90	AU-B,B- 613835	08/08/91
		AU-A- 5687490	23/05/91
		CA-A,C- 2008546	28/03/91
		DE-D,T- 69008469	01/09/94
		EP-A,B- 0420372	03/04/91
		FI-B- 95492	31/10/95
		JP-A- 3119196	21/05/91
		JP-B- 6021432	23/03/94