

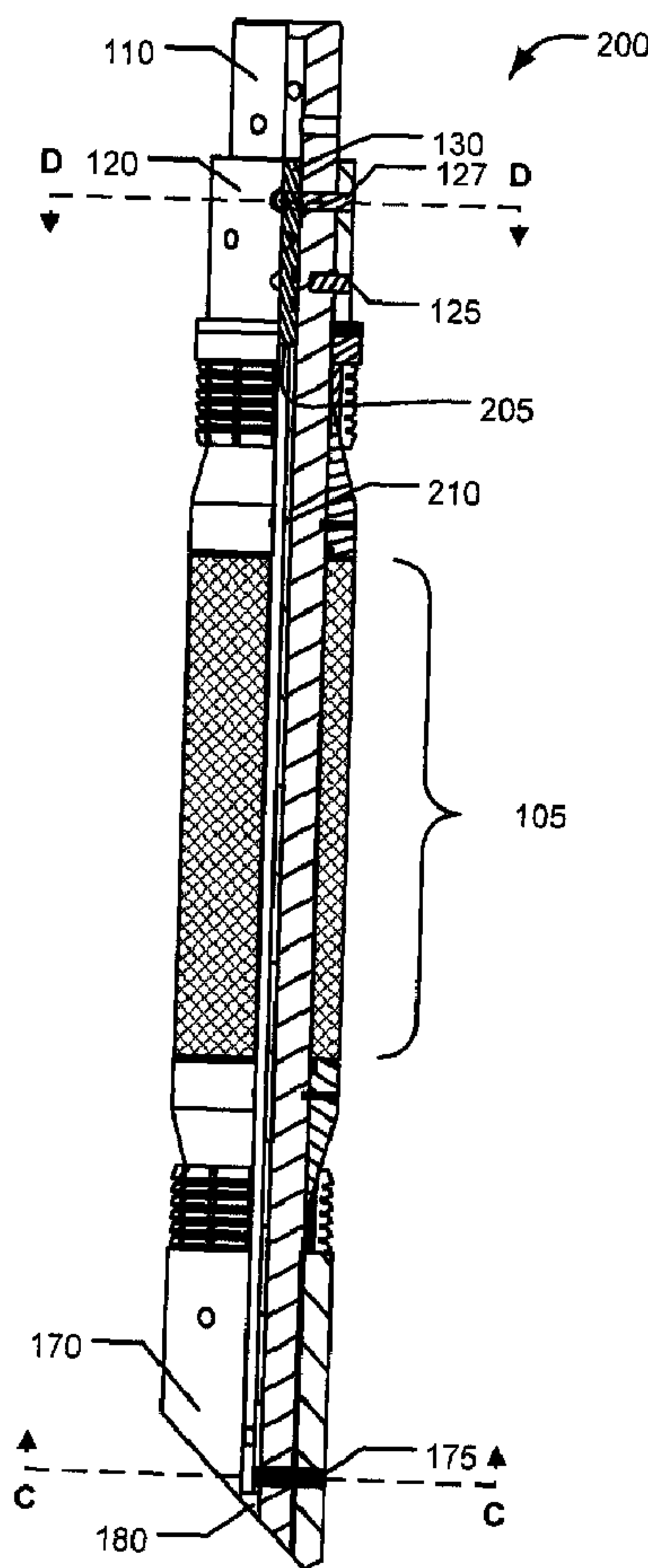

(22) Date de dépôt/Filing Date: 2010/07/16
(41) Mise à la disp. pub./Open to Public Insp.: 2011/02/28
(30) Priorité/Priority: 2009/08/31 (US12/551,077)

(51) Cl.Int./Int.Cl. *E21B 33/12* (2006.01),
E21B 23/01 (2006.01)
(71) Demandeur/Applicant:
WEATHERFORD/LAMB, INC., US
(72) Inventeurs/Inventors:
WARD, DAVID, US;
ZIMMERMAN, PATRICK J., US;
MCDONALD, BRADFORD JAMES, US
(74) Agent: GOODWIN MCKAY

(54) Titre : FIXATION DE BOUCHON PROVISOIRE COMPOSITE
(54) Title: SECURING A COMPOSITE BRIDGE PLUG



(57) Abrégé/Abstract:

A filament wound composite tube is inserted into a non-metallic mandrel below the core to support the core when holding pressure in the top annulus. The tube has a close-fit tolerance to the inner surface of the mandrel. The tube is secured in place with pins

(57) **Abrégé(suite)/Abstract(continued):**

through a mule shoe, such that the bore of the tube is not impeded. Alternately, a retainer with wickers is disposed in the mandrel below the core to support the core when holding pressure in the top annulus. The wickers are biased to engage with an inner surface of the mandrel, holding the insert in place under pressure. Axial movement of the core downward further engages the wickers with the mandrel, helping to support the load.

ABSTRACT

A filament wound composite tube is inserted into a non-metallic mandrel below the core to support the core when holding pressure in the top annulus. The tube has a close-fit tolerance to the inner surface of the mandrel. The tube is secured in place with pins through a mule shoe, 5 such that the bore of the tube is not impeded. Alternately, a retainer with wickers is disposed in the mandrel below the core to support the core when holding pressure in the top annulus. The wickers are biased to engage with an inner surface of the mandrel, holding the insert in place under pressure. Axial movement of the core downward further engages the wickers with the mandrel, helping to support the load.

SECURING A COMPOSITE BRIDGE PLUG

TECHNICAL FIELD

The present invention relates to the field of downhole sealing systems, and in particular to downhole tools such as bridge plugs, frac-plugs, and packers having a non-metallic
5 mandrels.

BACKGROUND ART

An oil or gas well includes a borehole extending into a well to some depth below the surface, typically lined with tubulars or casing to strengthen the walls of the borehole. Drillers typically fill the annular area formed between the casing and the borehole with cement, to
10 strengthen the borehole walls further and to set the casing permanently in the wellbore. They then perforate the casing to allow production fluid to enter the borehole for retrieval at the surface of the well.

Downhole tools with sealing elements are placed within the wellbore to isolate the production fluid or to manage production fluid flow through the well. The tools, such as plugs or
15 packers for example, can be constructed of cast iron, aluminum, other alloyed metals, or from composite materials, and have a malleable, synthetic element system. An element system typically includes a sealing element of a composite or synthetic rubber material that seals off an annulus within the wellbore to prevent the passage of fluids. The element system is compressed or swells, thereby expanding radially outward from the tool to seal with a surrounding tubular.
20 For example, a bridge plug or frac-plug is placed within the wellbore to isolate upper and lower sections of production zones. By creating a pressure seal in the wellbore, bridge plugs and frac-plugs allow pressurized fluids or solids to treat an isolated formation.

Where downhole tools use mandrels made of a filament wound composite material, the mandrel has an inner diameter bore that must be sealed then the bridge plug or frac-plug is
25 used. Typically, a solid core is placed into the mandrel, using O-rings to seal with the inner

diameter of the mandrel. The core is held in place with pins that fix it axially to the mandrel. These pins create a tensile weak point in the core, which limits the pressure and temperature to which the composite plug can be rated. If the pins fail, the core falls downhole, and the bridge plug or frac-plug must be replaced.

5 Metallic pins and cores have been used to attempt to eliminate this failure mode. But metal pins and cores can cause problems when milling out the installed plug, because the metallic components are not as easily milled as their composite counterparts. In addition, milling is least effective at the center of the plug where the core is.

SUMMARY OF INVENTION

10 An element is disposed below a core in a mandrel, providing support for the core against top annulus pressure. In one embodiment, a filament wound composite tube is inserted into the mandrel below the core to support the core when holding pressure in the top annulus. The tube is secured in place with pins through a mule shoe disposed with the mandrel, such that the inner diameter of the tube is not impeded. In some embodiments, the tube has a close-fit
15 tolerance to the existing inner diameter of the mandrel.

In another embodiment, a retainer with wickers is disposed below the core to support the core when holding pressure in the top annulus. The wickers are biased to engage with the inner diameter of the mandrel, holding the insert in place under pressure. Axial movement of the core downward furthers engage the wickers with the mandrel, helping to support the core.

20 BRIEF DESCRIPTION OF DRAWINGS

The accompanying drawings, which are incorporated in and constitute a part of this specification, illustrate an implementation of apparatus and methods consistent with the present invention and, together with the detailed description, serve to explain advantages and principles consistent with the invention. In the drawings,

Figure 1A is a cutaway view of a conventional composite bridge plug illustrating a sealing the bore of a mandrel;

Figure 1B is a cross-sectional view of the bridge plug of Fig. 1A at line C-C;

Figure 2A is a cutaway view of the composite bridge plug of Fig. 1A, with a tube
5 providing support to the core according to one embodiment;

Figure 2B is a cross-sectional view of the bridge plug of Fig. 2A at line D-D;

Figure 3 is a cutaway view of the composite mandrel of the bridge plug of Fig. 1A, illustrating installation of a retainer providing support to the core according to a second embodiment,

10 Figure 4 is a cutaway view of the composite mandrel of Fig. 3, illustrating a core supported by the retainer of Fig. 3;

Figure 5A is a perspective view of the retainer of Figs. 3-4 according to one embodiment;

Figure 5B is a cutaway view of the retainer of Fig. 5A;

15 Figure 5C is an end view of the retainer of Fig. 5A;

Figure 6A is a perspective view of the retainer of Figs. 3-4 according to another embodiment;

Figure 6B is a cutaway view of the retainer of Fig. 5A;

Figure 6C is an end view of the retainer of Fig. 5A; and

20 Figure 7 is a cross-sectional view of the composite mandrel of Fig. 3 along line B-B.

DESCRIPTION OF EMBODIMENTS

Although illustrated in the following with a bridge plug, the present invention is not so limited and embodiments can be used with other types of downhole tools as desired.

Fig. 1A is a cutaway view illustrating one embodiment of a downhole tool 100 according to the prior art, with a non-metallic mandrel 110 and an element system 105 disposed about the mandrel 110 configured to seal the downhole tool 100 to a surrounding tubular (not shown). In addition, the downhole tool comprises cones 145, slips 140, a sleeve 120, and a mule shoe 170. However, the components of the downhole tool 110 are illustrative and by way of example only, and other element systems or components of the downhole tool 100 can be used as desired for a particular application.

A bore 180 of the mandrel 110 is sealed with a core 130, a solid, typically non-metallic member. As illustrated in Fig. 1A, one or more sealing elements 135, such as O-rings, seal the core 130 to the inner diameter of the mandrel 110, preventing fluid flow through the bore 180 of the mandrel 110. Other techniques for sealing the core 130 to the inner diameter of the mandrel 170 can be used as desired. In one embodiment, the downhole end of the core 130 is chamfered to aid in insertion of the core 130 into the mandrel 110.

The core 130 is typically pinned in place with pins 127 through the sleeve 120 and mandrel 110 and through the core 130. As illustrated in Fig. 1B, a cross-sectional view along line D-D, multiple pins 125 are typically spaced apart around the circumference of the sleeve 120 to hold the sleeve 120 in place, and a plurality of spaced-apart pins 127 extend through the core 130, only one of which is illustrated in Fig. 1B. The pins 125 and 127 are typically metallic, such as an aluminum-bronze alloy, to provide sufficient tensile strength to hold the core in place under pressure. In some embodiments, the pins 125 and the pins 127 are the same pins.

Top annulus pressure (or bottom annulus pressure) can cause deformation of the core 130 and the sealing elements 135, resulting in a loss of seal, thus leaking fluids around the core 130. In more extreme cases, excess top annulus pressure breaks the pins 127 or the core 130, causing the core 130 to be pushed out of the mandrel 110 and lost down hole.

Turning now to Fig. 2A, a downhole tool 200 according to one embodiment comprises all of the components of Fig. 1A, but additionally provides support for the core 130 by an additional retainer member disposed in the bore of the mandrel 110. The additional support allows increasing the pressure rating of the downhole tool 200 over that of the downhole tool 100, and reduces the likelihood of loss of the core 130 downhole.

In one embodiment, a non-metallic tube 210 is composed of a filament wound polymeric composite material identical or similar to the polymeric composite material used to construct the element system 105 members, the mule shoe 170, and the mandrel 110. In other embodiments, the tube 210 can be formed from other high-temperature and pressure resistant non-metallic materials, such as a polyetheretherketone (PEEK) thermoplastic material. The tube 210 is inserted below the core 130, abutting a lower surface 205 of the core 130, as illustrated in Fig. 2A. The tube 210 extends along the mandrel 110 and is affixed to the mandrel 110 to support the tube 210 and thus the core 130. The tube 210 can be of any length, and affixed to the mandrel in any location or manner desired. In one embodiment, illustrated in Fig. 2A, the tube 210 extends along the bore 180 of the mandrel 110 to the mule shoe 170, where the tube 210 is pinned with pins 175 to affix the tube 210 to the mandrel 110.

The mule shoe 170 of Figs. 1A and 2A is typically threadedly connected to the mandrel 110, and affixed in place by pins 175, usually made of an aluminum-bronze alloy, through holes formed through the mule shoe 170 and mandrel 110, preventing rotational and axial movement of the mule shoe 170 relative to the mandrel 110. In one embodiment, at least one of the pins 175 also extend through at least a portion of the tube 210, as illustrated in the cross-sectional view along line C-C of Fig. 2B, preventing axial and rotational movement of the tube 210 relative to the mandrel 110. In one embodiment, all of the pins 175 extend into the tube 210, allowing all of the pins 175 to be made the same length.

The mule shoe 170 end of the tube 210 in one embodiment is straight cut for convenience, but can have any other desired configuration. In one embodiment, the pins 175 can be non-metallic pins, such as a polymeric composite, or elastomeric, such as TEFLON® pins. In other embodiments, metallic pins may be used.

Because drilling the pins 175 all of the way through the tube 210 would impede fluid flow through the smaller inner diameter of the tube 210, holes for the pins 175 are preferably drilled nearly all of the way through the wall of the tube 210, but not all the way through to break the surface of the inner diameter of the tube 210. In other embodiments, typically with large diameter mandrels, holes for the pins 175 can be drilled all the way through the tube 210's wall.

The tube 210 is open at the mule shoe 170 end, allowing fluid movement and pressure through the inner diameter of the tube 210 to the surface 205 of the core 130. To allow easier insertion of the core 130 into the mandrel 110, edges of the surface 205 can be chamfered if desired.

Because the tube 210 is non-metallic, it can be milled out easily. With the added support of the tube 210, in one embodiment, the pins 127 holding the core 130 are non-metallic, allowing easier milling, while still providing a core 130 that can hold against high top annulus pressures.

In one embodiment, the tube 210 is configured with a close tolerance to the inner diameter 180 of the mandrel 110, providing frictional support to the tube 210, and reducing annual pressure between the tube 210 and the mandrel 110. Close fitting of the tube 210 to the mandrel 110 also provides support for the mandrel 110.

In another embodiment, a retainer member 320 provides support for the core 130, engaging the inner diameter of the mandrel 110, preventing axial movement of the inner retainer member 320, and therefore the core 130.

As illustrated in Fig. 3, in this embodiment, an installation tool 310 is used to set the retainer 320 in the mandrel 110 at a desired location. A frusto-conical section 315 of the installation tool 310 allows insertion of the retainer 320 onto a reduced diameter section 317 of the installation tool 310. The installation tool 310 then positions the retainer 320 at the desired location and sets the retainer 320 to engage the mandrel 110. In one embodiment, the retainer 320 may be compressed prior to insertion into the mandrel 110, and held in the compressed position by a positioning sleeve 330 shown in dotted lines in Fig. 3, to indicate its removal after

positioning. In a further embodiment, assembly tooling may be used to expand the retainer 320 after insertion.

The installation tool 310 is then withdrawn and the core 130 is inserted into the mandrel 110 to abut the retainer 320 as illustrated in Fig. 4. The retainer 320 thus supports the core 130. Instead of abutting a flat lower surface 205 of the core 130, as described above, the core 130 has a frusto-conical section 410, similar to the conical section 315 described above for the installation tool 310, allowing positioning the retainer 320 on a reduced diameter section 420 of the core 130. The section 3 is sealed to the inner diameter 180 of the mandrel 110 with O-rings 135. Alternate techniques for sealing the core 130 to the mandrel 110 can be used as desired.

The retainer 320 is typically made of an aluminum-bronze alloy, but can be made of a soft cast iron or other materials as desired, for ease of milling.

Fig. 5A is a perspective view illustrating one embodiment of the inner retainer 320. As described above, hardened wicker sections 510 are spaced around the circumference of the inner retainer 320. The inner retainer 320 is roughly C-shaped in cross-section, best illustrated in Fig. 5C, allowing radial expansion of the inner retainer 320 by widening the gap 530 between two wicker sections 510 under pressure from the installation tool 310's frusto-conical section 315 and the frusto-conical section 410 of the core 130. As best illustrated in Fig. 5C, grooves 620 are manufactured longitudinally in the inner retainer 510, providing break points that allow the wicker sections 510 to separate from each other at least in part as they move radially outwardly. The wickers 510, best illustrated in Fig. 5B, are biased against downhole movement. The specific configuration of the wickers 510 is illustrative and by way of example only, and any desired wicker configuration can be used. As illustrated best in Fig. 5B, the inner diameter of the retainer 320 is constant across the length of the retainer 320, so that the frusto-conical portion 315 of the installation tool 310 and the similar section 420 of core 130 can cause radial expansion of the retainer 320.

As illustrated in Figs. 5A and 5B, in one embodiment a portion 540 of the retainer 320 has a smooth outer diameter, except for the longitudinal grooves 520 for ease of handling. In other embodiments, the portion 540 may be omitted.

5 Figs. 6A–C illustrate a second embodiment of the retainer 320 that eliminates the smooth section 540, providing wickers 510 along the entire axial length of the retainer 320. As illustrated in Fig. 6B, the inner diameter 610 of this embodiment decreases along the axis of the retainer 320 in a downhole direction. The installation tool 310 and the core 320 can thus be formed without the frusto-conical sections 315 and 410, respectively, and use the reduced diameter sections 317 and 420 to engage with and force the wicker section 510 radially outward
10 to engage with the mandrel 110.

Fig. 7 a cross-sectional view along line B-B of the system of Fig. 3. As the frusto-conical section 315 (or, in the embodiment of Fig. 6A–C, the reduced diameter section 317) engages the retainer 320, the installation tool 310 urges hardened wicker sections 510 radially outward to engage the mandrel 110. Once engaged, the wicker sections 510 prevent further axial
15 movement of the inner retainer 320 and the downhole tool 200, and the core 130 can be disposed with and supported by the retainer 320.

Although described above with a separate installation tool 310, in some embodiments, the core 130 is used as an installation tool to position and set the retainer 320 in the bore 180 of the mandrel 110.

20 While certain exemplary embodiments have been described in details and shown in the accompanying drawings, it is to be understood that such embodiments are merely illustrative of and not devised without departing from the basic scope thereof, which is determined by the claims that follow.

CLAIMS

We claim:

1. A plug system for a mandrel having a bore, comprising:

a non-metallic plug comprising:

a non-metallic core configured for disposal within the bore of the mandrel;

5 and

a seal disposed about the non-metallic core for sealingly engaging the non-metallic core with the inner diameter of the mandrel;

a support element, configured for disposal within the bore of the mandrel axially adjacent to the non-metallic plug and affixed to the mandrel.

10 2. The plug system of claim 1, wherein the support element comprises a non-metallic tube disposed in the bore of the mandrel, abutting the non-metallic core and pinned to the mandrel.

3. The plug system of claim 1, wherein the support element comprises a retainer, comprising:

15 a plurality of wickers, configured to engage an inner surface of the mandrel, preventing downhole movement of the retainer.

4. The plug system of claim 3, wherein the retainer is radially compressible for insertion into the mandrel.

5. The plug system of any one of claims 1 to 4, further comprising:

20 a plurality of pins, inserted radially through a wall of the mandrel into the support element, affixing the support element to the mandrel.

6. The plug system any one of claims 1 to 5, wherein the support element has an outer diameter in close tolerance with an inner diameter of the mandrel.

7. A downhole tool, comprising:
a non-metallic mandrel, having a bore;
a non-metallic element system disposed about the mandrel, comprising:
a sealing element, configured for radial expansion;
5 a non-metallic core, comprising:
a non-metallic member configured for disposal within the bore of the
mandrel; and
a seal disposed with the non-metallic member for sealingly engaging the
non-metallic core with an inner surface of the mandrel;
10 a support element, configured for disposal within the bore of the mandrel axially
adjacent to the non-metallic plug and affixed to the mandrel.
8. The downhole tool of claim 7, wherein the support element comprises a non-
metallic tube disposed in the bore of the mandrel, abutting the non-metallic core, and pinned to
the mandrel.
- 15 9. The downhole tool of claim 7, wherein the support element comprises a retainer,
comprising:
a plurality of wickers, configured to engage the inner surface of the mandrel,
preventing downhole movement of the retainer.
10. The downhole tool of claim 9,
20 wherein the retainer is radially expandable for engagement with the inner surface
of the mandrel, and
wherein the core further comprises an expander portion, configured to engage the
retainer and radially expand the retainer.
11. The downhole tool of any one of claims 7 to 10, further comprising:
25 a plurality of pins, inserted radially through a wall of the mandrel into the support
element, affixing the support element to the mandrel.

12. The downhole tool of any one of claims 7 to 11, wherein the support element has an outer diameter in close tolerance with the inner diameter of the mandrel.

13. A method of sealing a bore of a mandrel, comprising:
5 disposing a core in the bore of the mandrel;
sealing the core to an inner surface of the mandrel;
affixing the core to the mandrel;
disposing a support element axially adjacent to the core in the bore of the
mandrel;
affixing the support element to the mandrel.

10 14. The method of claim 13, wherein affixing the support element to the mandrel comprises pinning the support element to a mule shoe of the mandrel.

15. The method of claim 13, wherein affixing the support element to the mandrel comprises engaging a wicker of the support element with the inner surface of the mandrel.

15 16. The method of any one of claims 13 to 15, wherein disposing a support element comprises:
disposing the support element on an installation tool,
positioning the support element in the bore of the mandrel with the installation
tool;
radially expanding the support element with an expander portion of the core to
20 engage the inner surface of the mandrel; and
removing the installation tool.

17. The method of any one of claims 13 to 16, wherein the support element is a non-metallic tube.

25 18. The method of any one of claims 13 to 16, wherein the core is non-metallic and the support element is metallic.

19. A method of sealing a bore of a mandrel, comprising:
disposing a support element in the bore of the mandrel;
disposing a core in the bore of the mandrel, comprising:
inserting an expander portion of the core into the support element;
radially expanding the support element with the expander portion; and
engaging the support element with an inner surface of the mandrel to
prevent axial movement of the support element and the core; and
affixing the core to the mandrel.

5

L

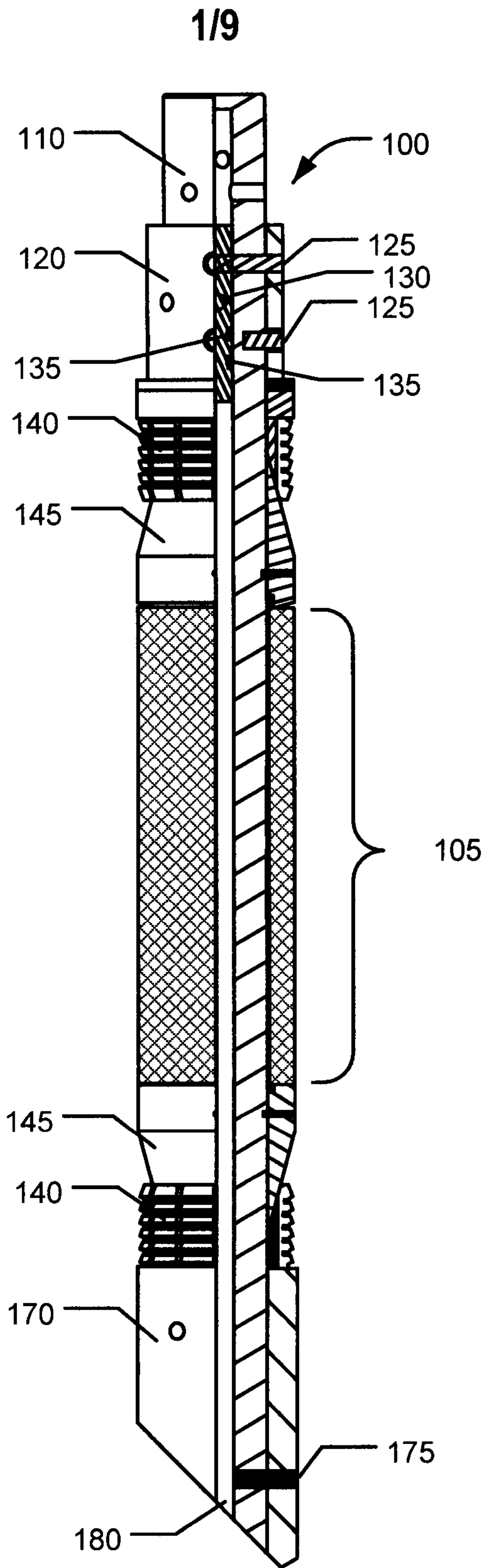

Figure 1 A
(prior art)

L

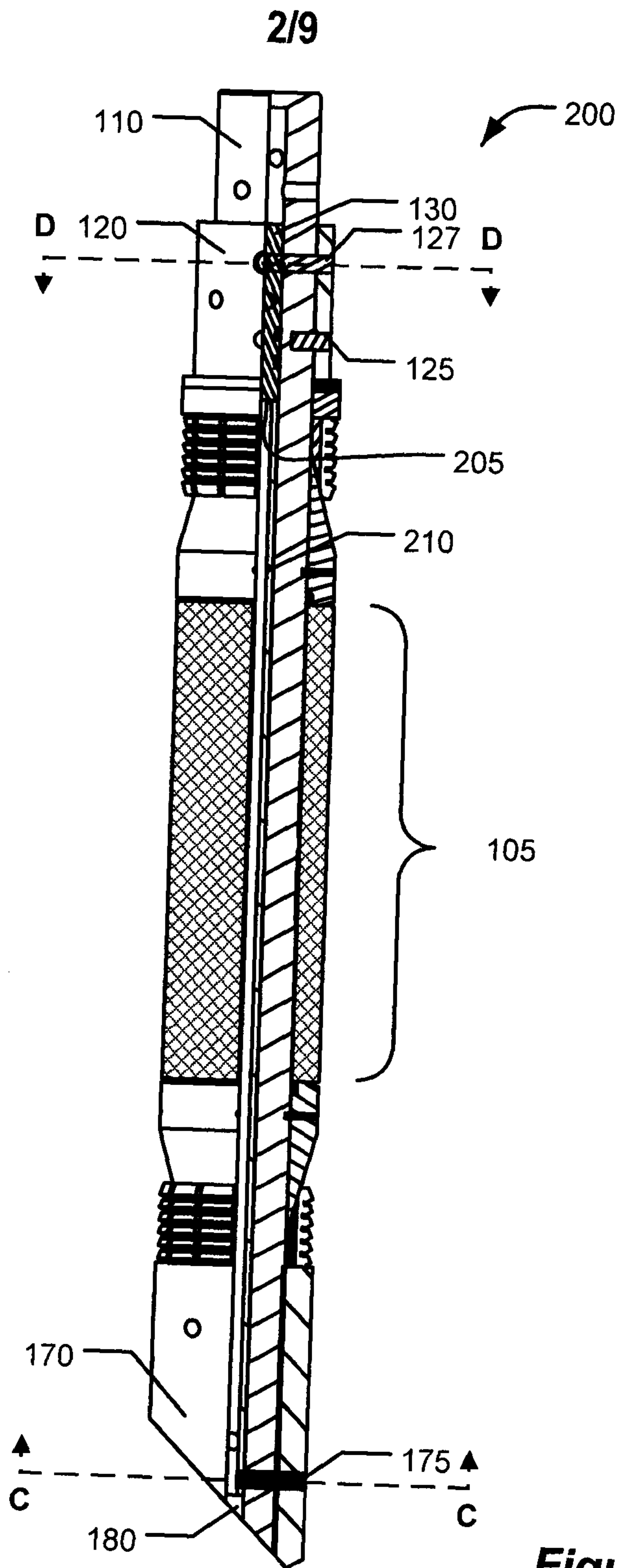
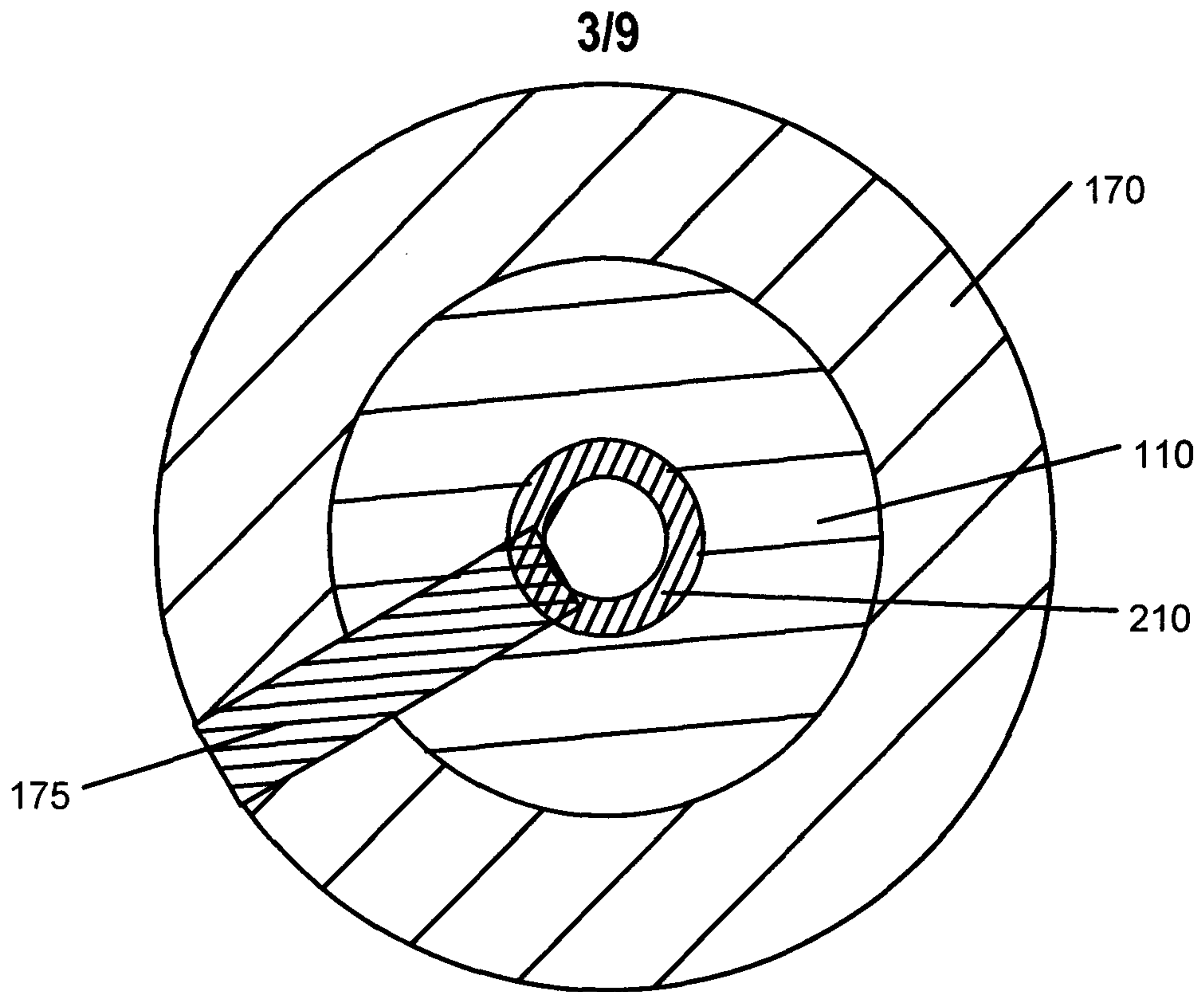

Figure 2A

L



SECTION C-C

Figure 2B

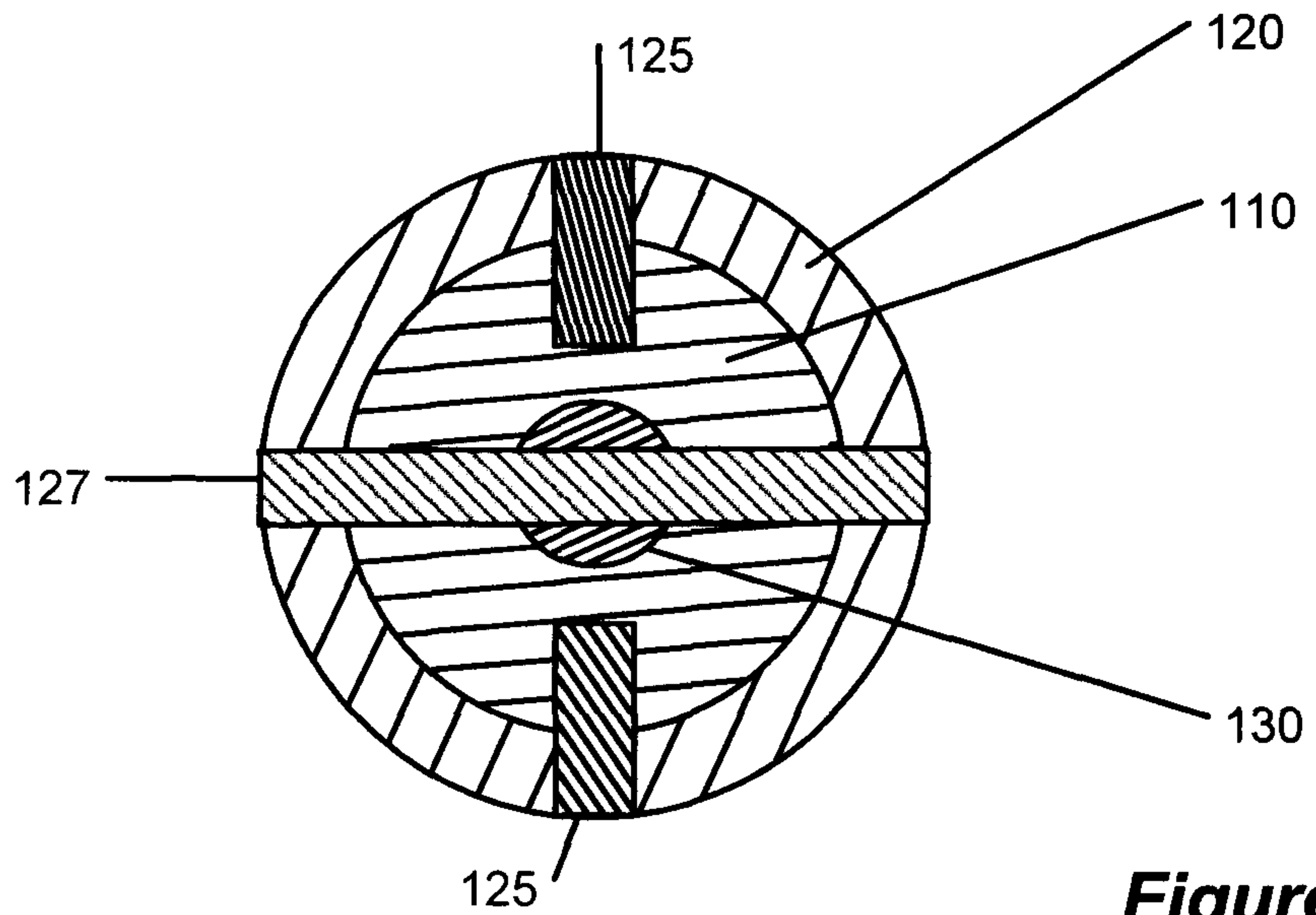

SECTION D-D

**Figure 1B
(prior art)**

7

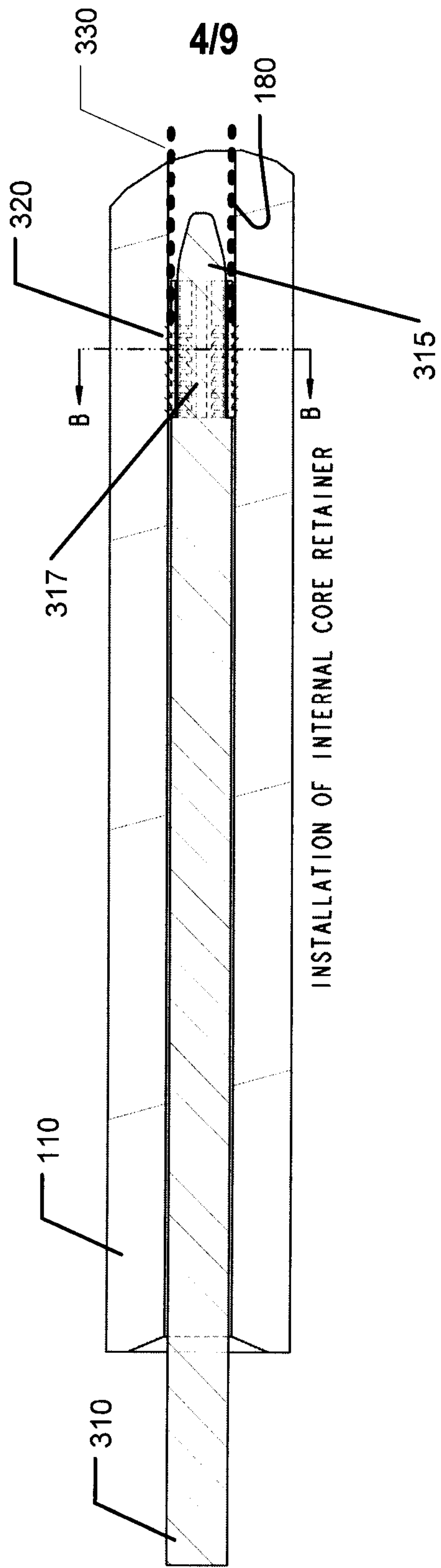

Figure 3



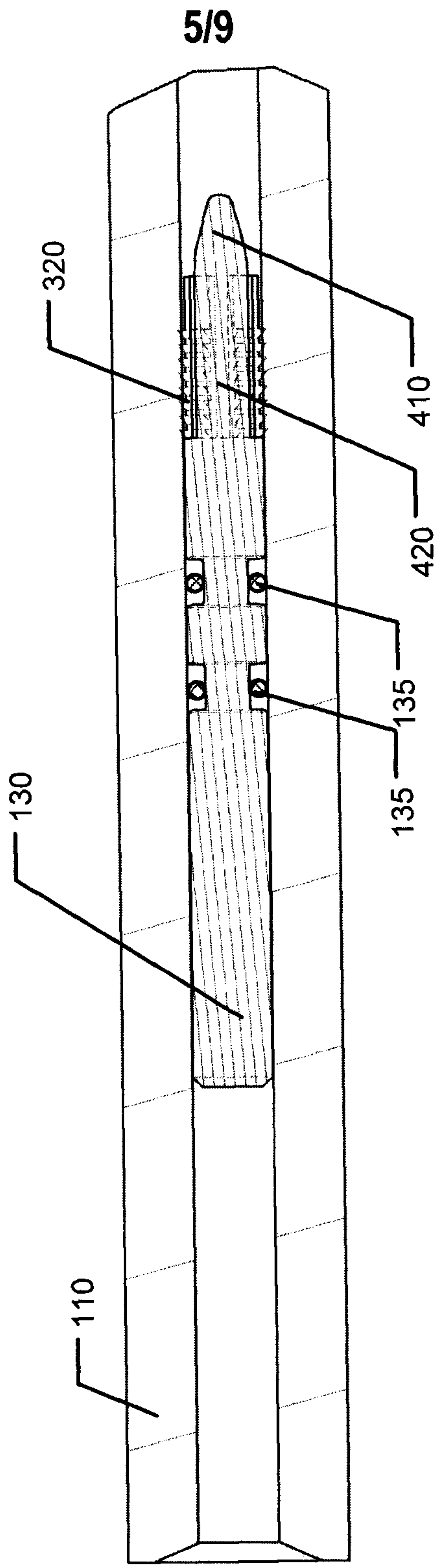

Figure 4



6/9

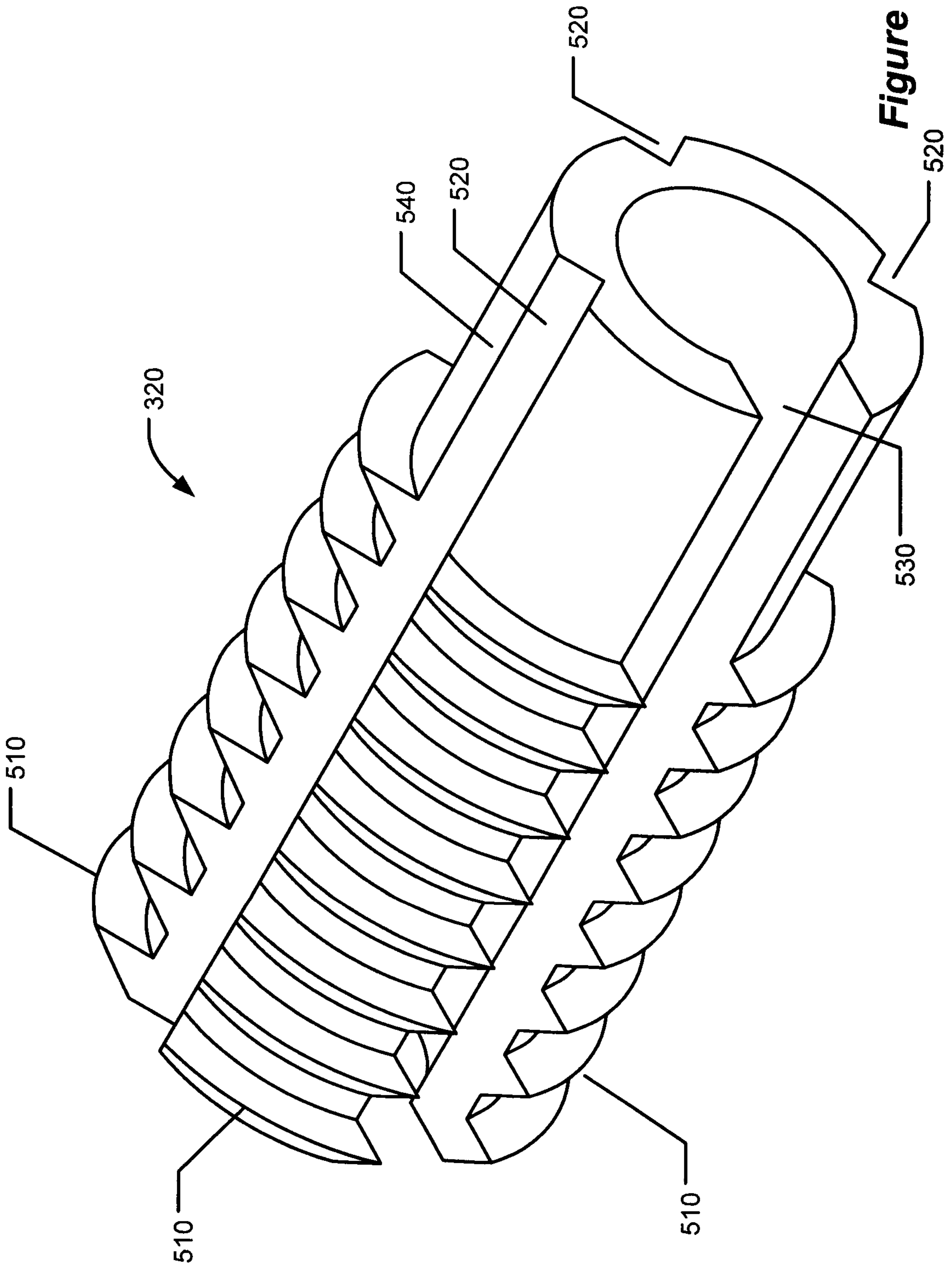

Figure 5A



L

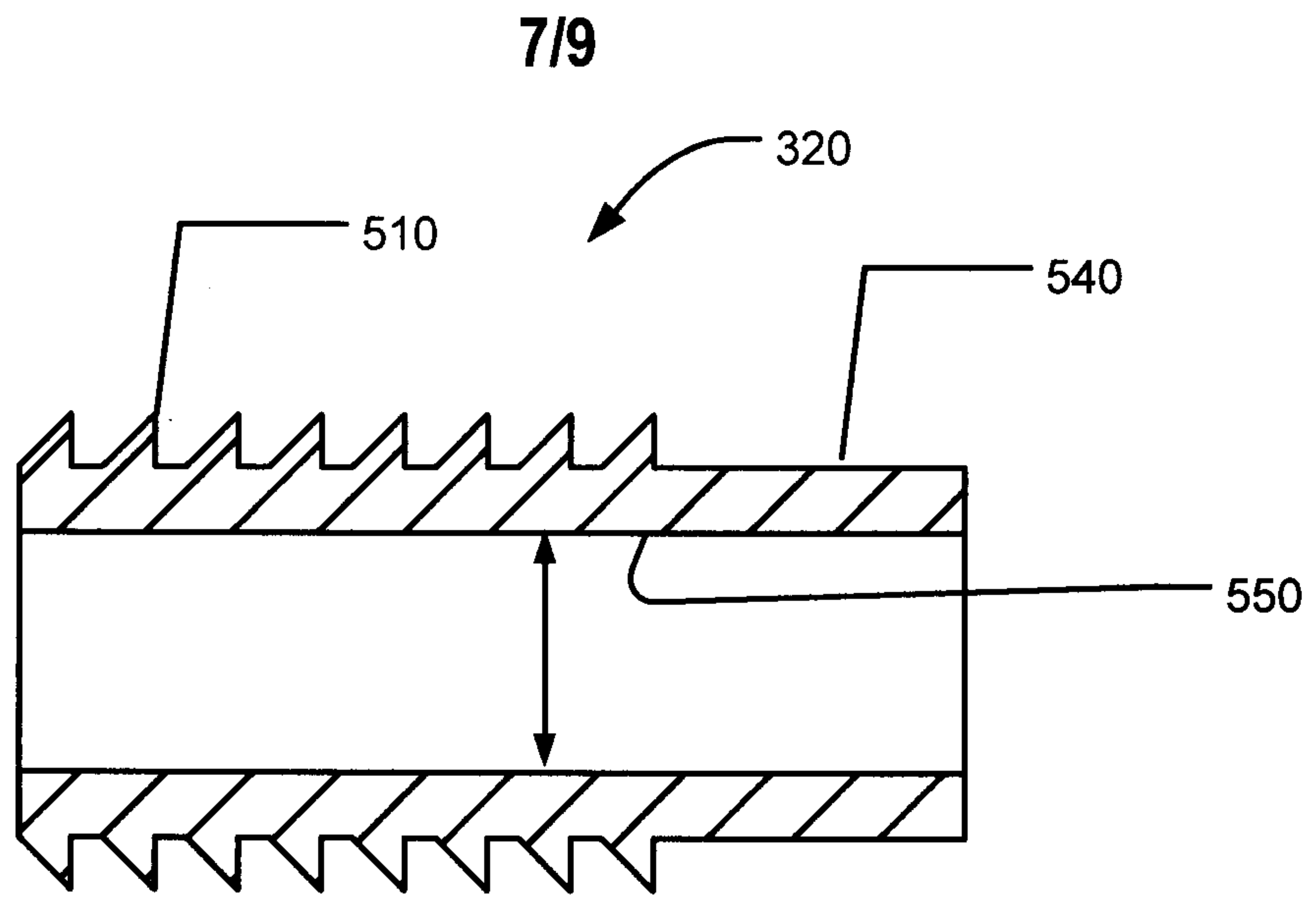

Figure 5B

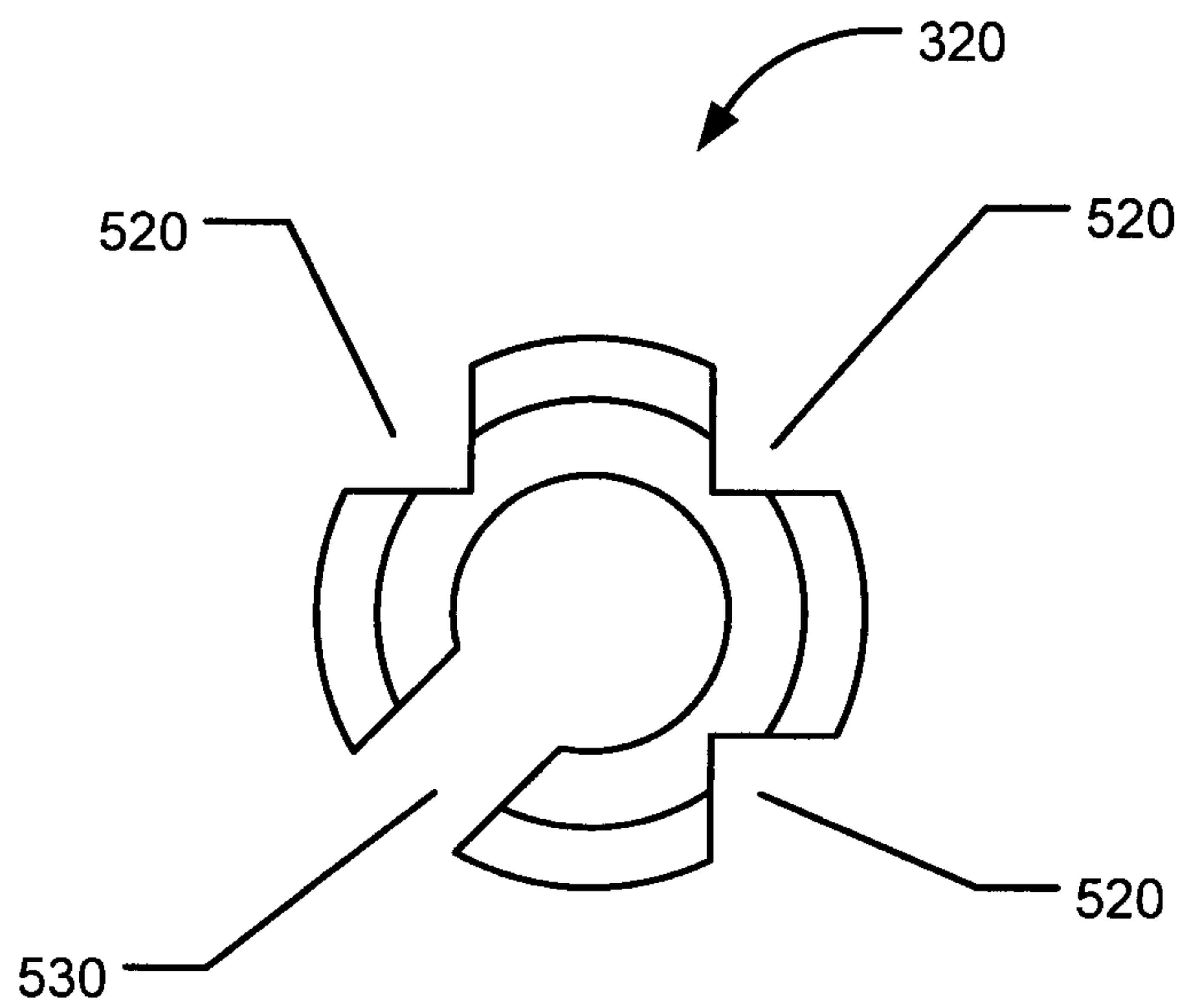

Figure 5C

7

L

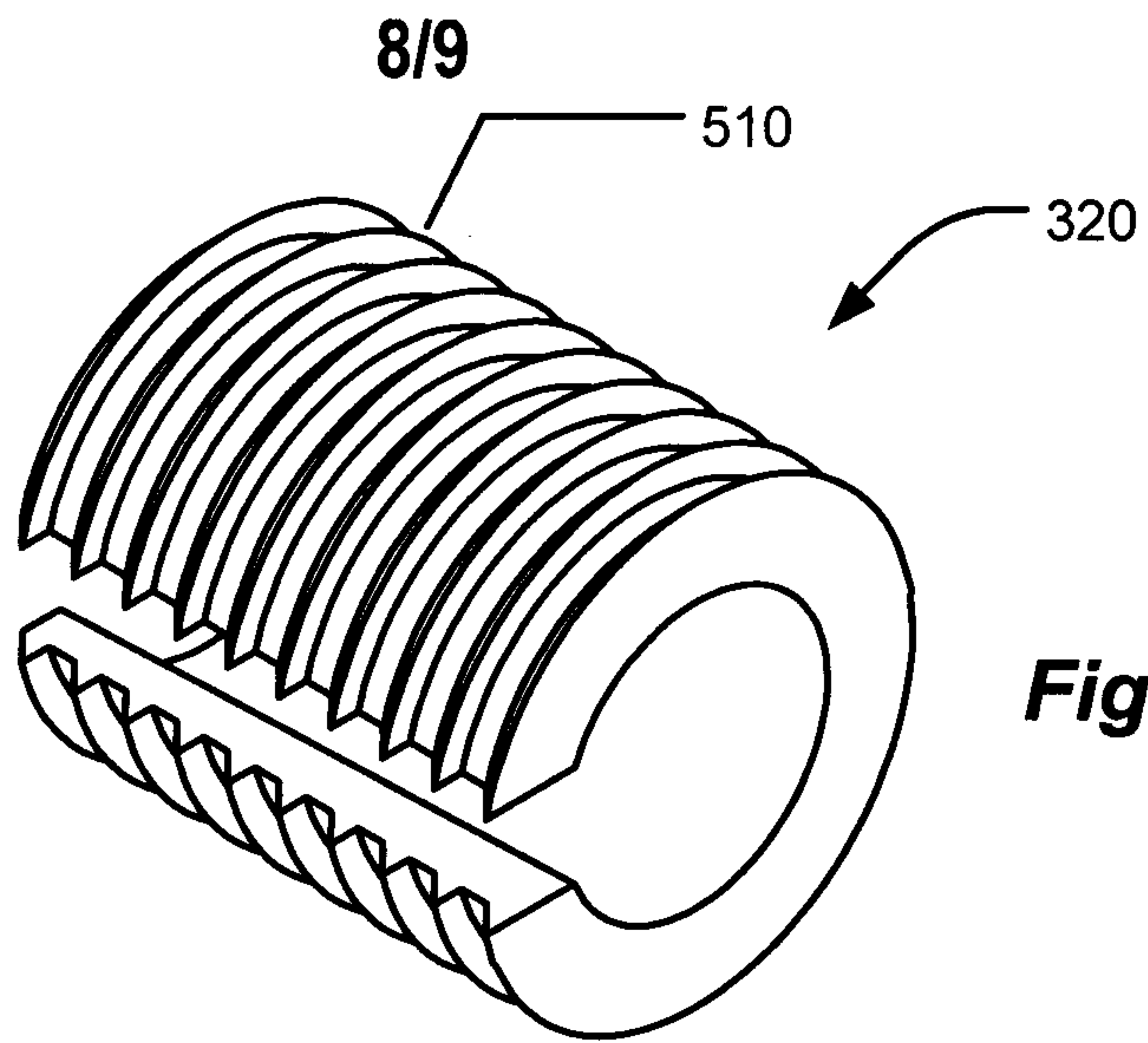

Figure 6A

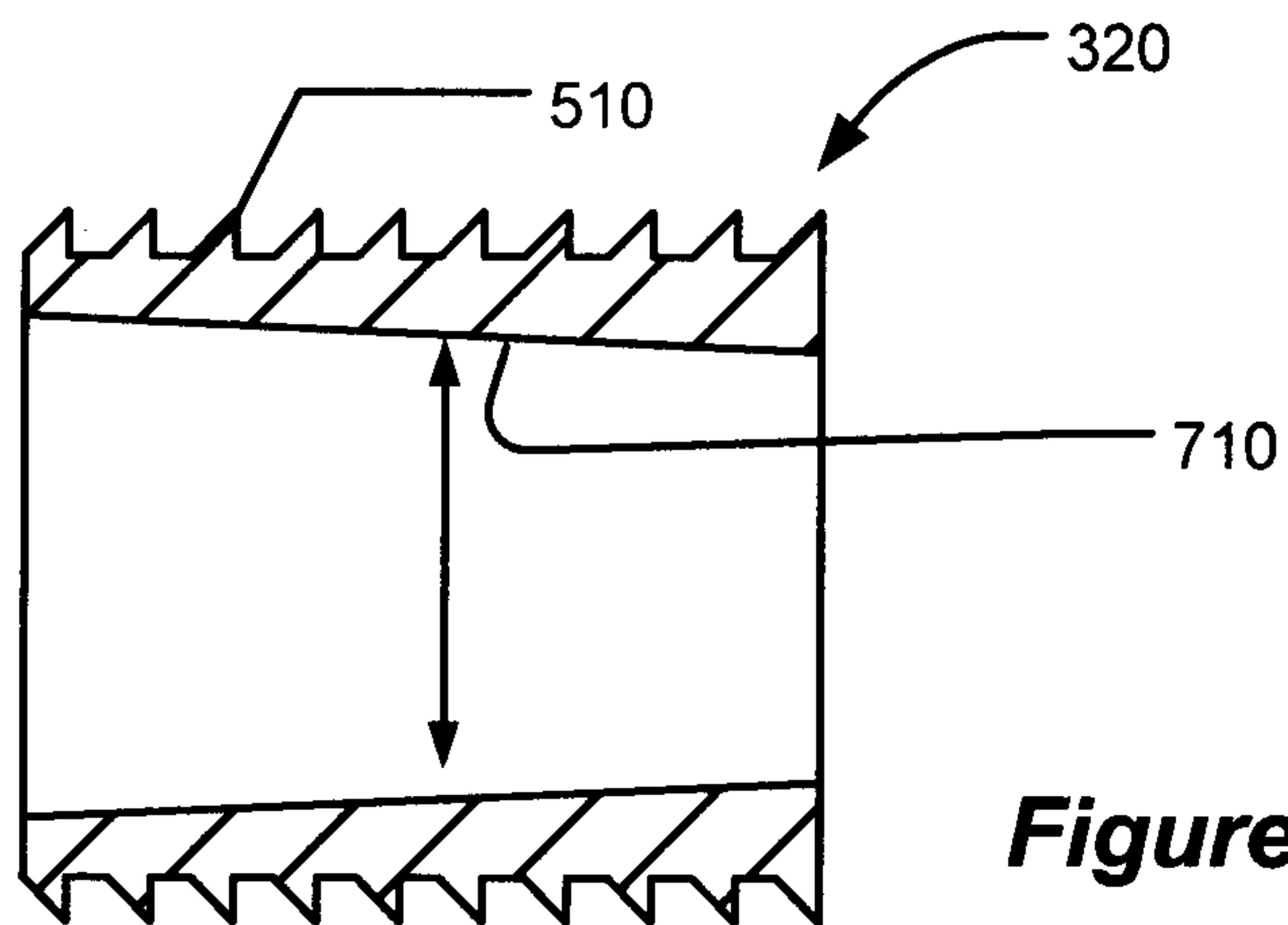

Figure 6B

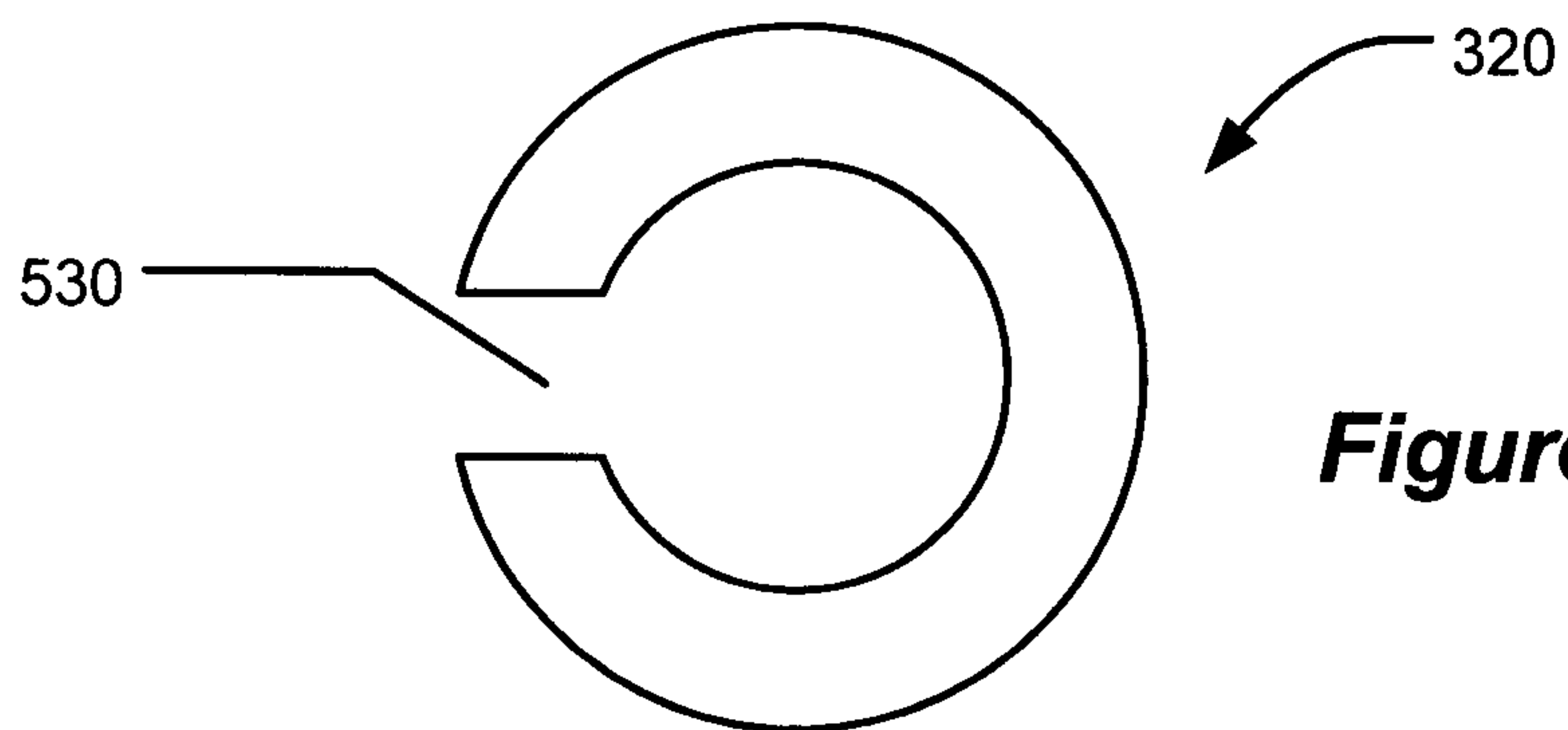
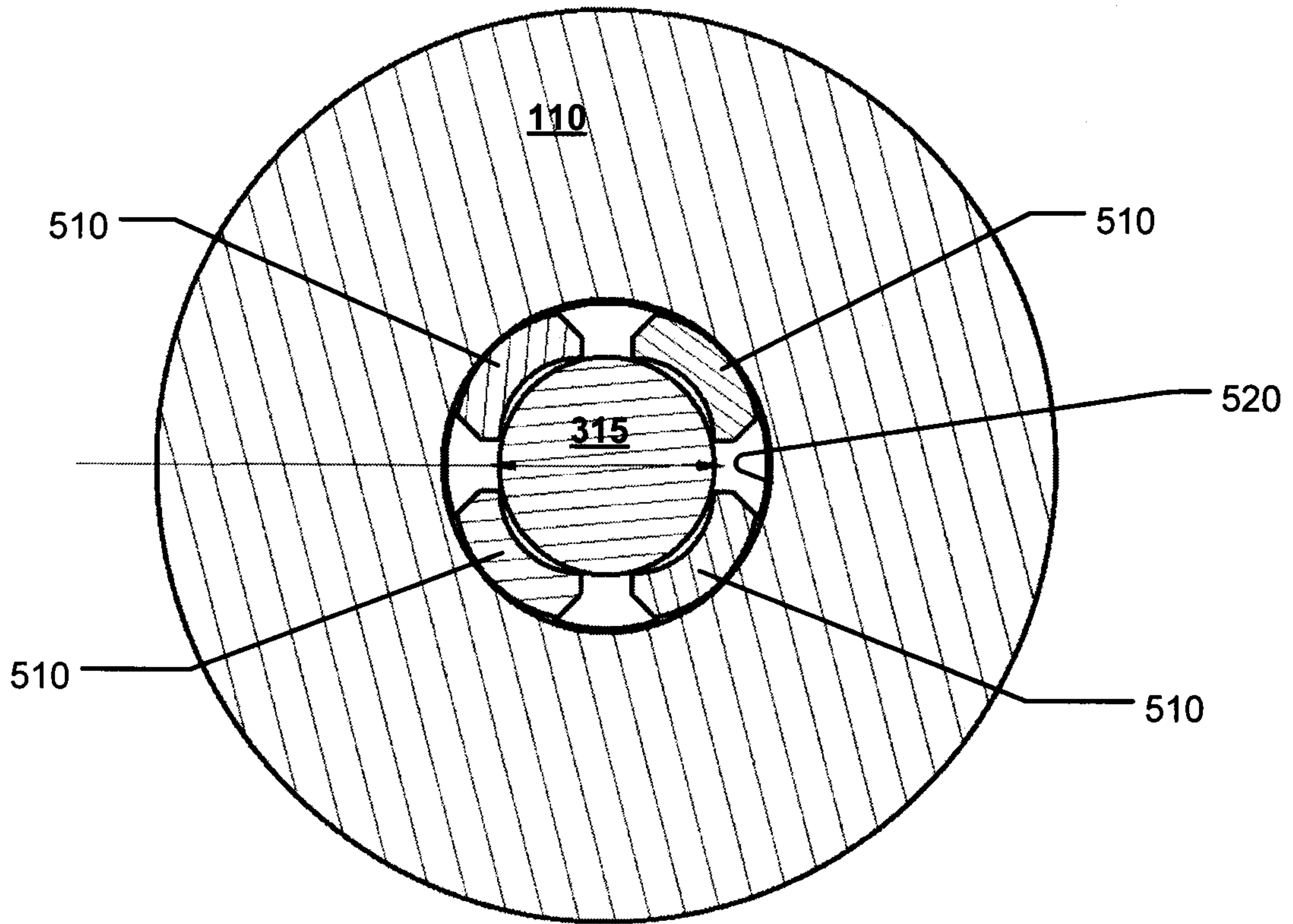

Figure 6C

7

L



SECTION B-B

Figure 7

7

