

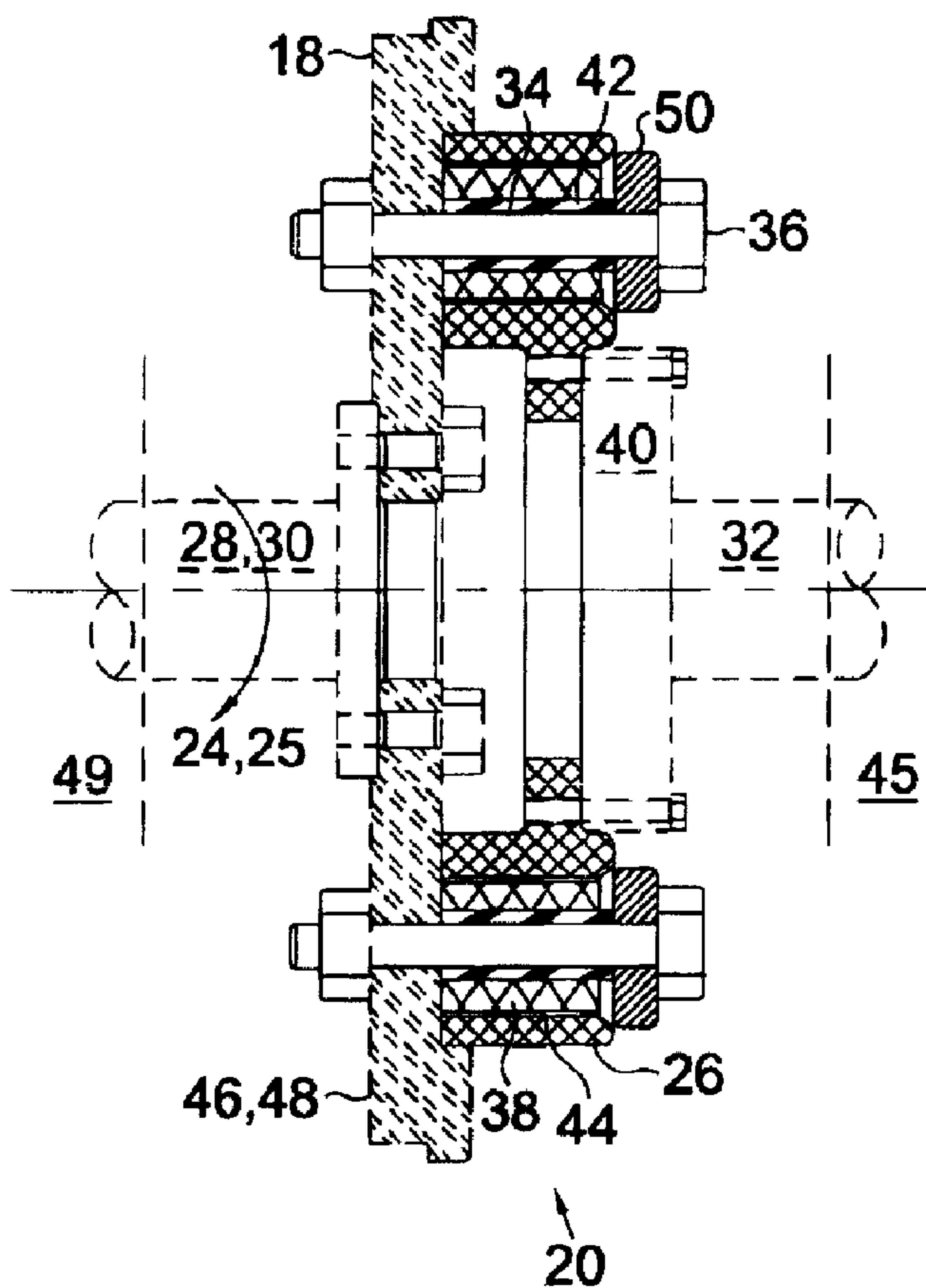

(22) Date de dépôt/Filing Date: 2004/03/19
 (41) Mise à la disp. pub./Open to Public Insp.: 2005/06/23
 (45) Date de délivrance/Issue Date: 2011/08/02
 (30) Priorité/Priority: 2003/12/23 (US10/743,078)

(51) Cl.Int./Int.Cl. *F16D 3/12* (2006.01),
F16D 3/28 (2006.01)
 (72) Inventeur/Inventor:
JURANKO, ANTON, CA
 (73) Propriétaire/Owner:
JURANKO, ANTON, CA

(54) Titre : METHODE DE REDUCTION DU CHOC DE COUPLE D'UNE TRANSMISSION
 (54) Title: METHOD OF REDUCING TORQUE SHOCK ON A TRANSMISSION



(57) Abrégé/Abstract:

Torque shock peaks when an automatic transmission shifts gears. A method of reducing this torque shock to prolong the life of engines, transmissions and the entire power train in vehicles and heavy equipment most generally comprises the steps of

(57) **Abrégé(suite)/Abstract(continued):**

transmitting rotational power through a torque shock absorber having a generally cylindrical housing adapted for attachment to a drive on a flywheel end and to a driven shaft on the other flywheel end. Thereby peak torque loads transmitted through the torque shock absorber are reduced. In a preferred embodiment of the invention the torque shock absorber comprises a housing having peripheral spaced bolts there through. Bolt openings therein are surrounded by a rubber bushing in the housing so that when the torque shock absorber is bolted to a flywheel peak torque loads are absorbed by the rubber bushings. The most preferred placement for the torque shock absorber in the power train is between an engine and remotely mounted transmission. This torque shock absorber is not "a coupling". It is a torque shock absorber invented with the intention to improve the performance or replace the rubber element drive shaft "Spicer" #908464. That is why this torque shock absorber is a totally new invention.

CA 02460978 2004-03-19

ABSTRACT OF THE DISCLOSURE

Torque shock peaks when an automatic transmission shifts gears. A method of reducing this torque shock to prolong the life of engines, transmissions
5 and the entire power train in vehicles and heavy equipment most generally comprises the steps of transmitting rotational power through a torque shock absorber having a generally cylindrical housing adapted for attachment to a drive on a flywheel end and to a driven shaft on the other flywheel end. Thereby peak torque loads transmitted through the torque shock absorber are reduced. In a preferred
10 embodiment of the invention the torque shock absorber comprises a housing having peripheral spaced bolts there through. Bolt openings therein are surrounded by a rubber bushing in the housing so that when the torque shock absorber is bolted to a flywheel peak torque loads are absorbed by the rubber bushings. **The most preferred placement for the torque shock absorber in the power train is between an**
15 **engine and remotely mounted transmission.**

This torque shock absorber is not “a coupling”. It is a torque shock absorber invented with the intention to improve the performance or replace the rubber element drive shaft “Spicer” #908464.

That is why this torque shock absorber is a totally new invention.

CA 02460978 2004-03-19

**METHOD OF REDUCING TORQUE SHOCK
ON A TRANSMISSION**

FIELD OF THE INVENTION

This invention relates to torque shock experienced between an engine and an Automatic transmission when gears are shifted. More particularly this invention relates to a method of reducing this torque shock to prolong the life of engines, transmissions, and the entire power train in vehicles and heavy equipment.

This torque shock absorber is not "a coupling". It is a torque shock absorber invented with the intention to improve the performance or replace the rubber element drive shaft "Spicer" #908464.

That is why this torque shock absorber is a totally new invention.

BACKGROUND OF THE INVENTION

Torque shock between power source and remotely mounted automatic transmissions has long been, and continues to be a problem. Torque shock is not only hard on automatic transmissions, but on the crank shaft of engines, and the entire drive train in vehicles. Particularly on large trucks, and on heavy equipment having automatic transmissions, fast, forceful, and sudden contact between shifting gears roughly jerks the entire vehicle. High RPM shifts, either up or down, generates substantial torque shock. This torque shock results in a premature failure of engines, transmissions, drive shafts, and differentials. To correct the problem of torque shock, a torque shock absorbing apparatus that decreases the peak torque shock when gears are automatically shifted, is needed.

CA 02460978 2004-03-19

One aspect of this invention provides for a method of reducing this torque shock to prolong the life of engines, transmissions, and the entire power train in vehicles and heavy equipment most generally comprises the steps of transmitting rotational power through a torque shock absorber having a generally cylindrical housing adapted for attachment to a drive on one cylindrical end and to a driven shaft on the other cylindrical end. Thereby peak torque loads transmitted through the torque shock absorber are reduced.

In a preferred aspect of this invention a preferred embodiment provides for the torque shock absorber comprising a housing having peripheral spaced bolts there through. Bolt openings therein are surrounded by a rubber bushing in the housing so that when the torque shock absorber is bolted to a flywheel, peak torque loads are absorbed by the rubber bushings. The most preferred placement for the torque shock absorber in the power train is between an engine and a remotely mounted automatic transmission.

Various other objects, advantages and features of this invention will become apparent to those skilled in the art from the following description in conjunction with the accompanying drawings.

CA 02460978 2004-03-19

The inventor has determined that the position for the torque shock absorber is directly on the engine or power source, before the automatic transmission. When installed, the torque shock absorber absorbs torque buildup during gear shifting. Drive shaft vibrations are eliminated. The torque shock absorber not only promotes smoother shifting of gears, and a smoother acceleration of the vehicle, but most importantly it reduces fatigue and wear on gears, bearings, and shafts within the transmission, as well as within all components within the entire remainder of the drive train. Peak torque and wear, and all of the resulting fatigue and failure of gears, shafts, bearings, universal joints, all along the entire drive train can be substantially reduced. While a torque shock absorber can compliment small vehicles having small engines and power transmission, the torque shock absorber has most immediate application on relatively large vehicles having large engines which transmit substantial power.

OBJECTS OF THE INVENTION

It is an object of this invention to disclose a method of substantially reducing maintenance, and extending the life of engines, automatic transmissions, and all other components in the drive train of a vehicle. It is an object of this invention to disclose a method of reducing peak torque caused by both up and down shifting of gears. It is yet a further object of this invention to disclose a method of producing smoother acceleration and deceleration of a vehicle.

CA 02460978 2004-03-19

FIGURES OF THE INVENTION

Figure 1 is a cross sectional view of a torque shock absorber mounted on a flywheel transmitting power to a drive shaft.

Figure 2 is a front view of the torque shock absorber shown in figure 1.

The following is a discussion and description of the preferred specific embodiments of this invention, such being made with reference to the drawings, wherein the same reference numerals are used to indicate the same or similar parts and/or structure. It should be noted that such discussion and description is not meant to unduly limit the scope of the invention.

DESCRIPTION OF THE INVENTION

Turning now to the drawings and more particularly to figure 1 we have a perspective view of a cross sectional view of a torque shock absorber 20 mounted on a flywheel 18 transmitting power to a drive shaft 32. Most generally a method of reducing peak torque loads 25 caused by automatic gear shifting comprises the steps of: transmitting rotational power 24 through a torque shock absorber 20, having a generally cylindrical housing 26 adapted for attachment to a crankshaft 28 on one cylindrical end, and to a drive shaft 32 on the other cylindrical end. Thereby peak torque loads 25 transmitted through the torque shock absorber 20 are reduced.

The torque shock absorber 20 comprises a housing 26 having peripheral spaced bolt openings 34 and having bolts 36 there through. Said bolt openings 34 are surrounded by a rubber bushing 38 in the housing 26 so that when the torque shock absorber 20 is bolted to a driven flange 40 peak torque loads 25 are absorbed by the rubber bushings 38. Within this specification rubber is defined to include a resilient plastic.

In the most preferred embodiment of the invention the rubber bushings 38 surround a steel bolt sleeve 42. The rubber bushings 38 are surrounded by a cylindrical steel ring 44 to facilitate positioning them within the housing 26. The rubber bushings are bonded between the steel bolt sleeve 42 and the cylindrical steel ring 44. A centering flanges 50 to axially secure the housing 26 to a drive flange 46 of the drive shaft 28. In the most preferred embodiment of the invention the drive shaft 28 and drive flange 46 comprise a flywheel 48 turned by a crankshaft 30 on an internal combustion engine 49. The driven shaft 32 is adapted to be driven by a driven flange 40 bolted to an inner central portion of the driven end of the generally cylindrical torque shock absorber 20. The driven shaft 32 inputs power to an automatic transmission 45.

While the invention has been described with preferred specific embodiments thereof, it will be understood that this description is intended to illustrate and not to limit the scope of the invention, which is defined by the following claims.

I CLAIM

- 1) A method of reducing peak torque loads caused by automatic gear shifting comprising the steps of: transmitting rotational power through a torque shock absorber having a generally cylindrical housing adapted for attachment to a drive shaft on one cylindrical end and to a driven shaft on the other cylindrical end; so that peak torque loads transmitted through the torque shock absorber are reduced; wherein the torque shock absorber includes peripheral spaced bolts through openings in the housing and wherein said bolt opening are surrounded by a rubber bushing in the housing so that, when the bolts are fastened to a flange of the drive shaft, torque loads are absorbed by the rubber bushings; wherein each bolt also extends through a centering flange which engages the torque absorber housing opposite the drive shaft flange to limit axial movement of the torque absorber housing relative the flange.
- 2) A method as in claim 1 wherein the rubber bushings surround a steel bolt sleeve.
- 3) A method as in claim 2 wherein the rubber bushings are surrounded by a cylindrical steel ring to facilitate positioning within the housing.
- 4) A method as in claim 3 wherein the driveshaft and drive flange comprises fly wheel turned by a crankshaft on an internal combustion engine.
- 5) A method as in claim 4 where the drive shaft is adapted to be driven by a driven flange bolted to an inner center portion of the driven end of the generally cylindrical torque shock absorber.
- 6) A method as in 5 where in the driven shaft inputs power to an automatic transmission.

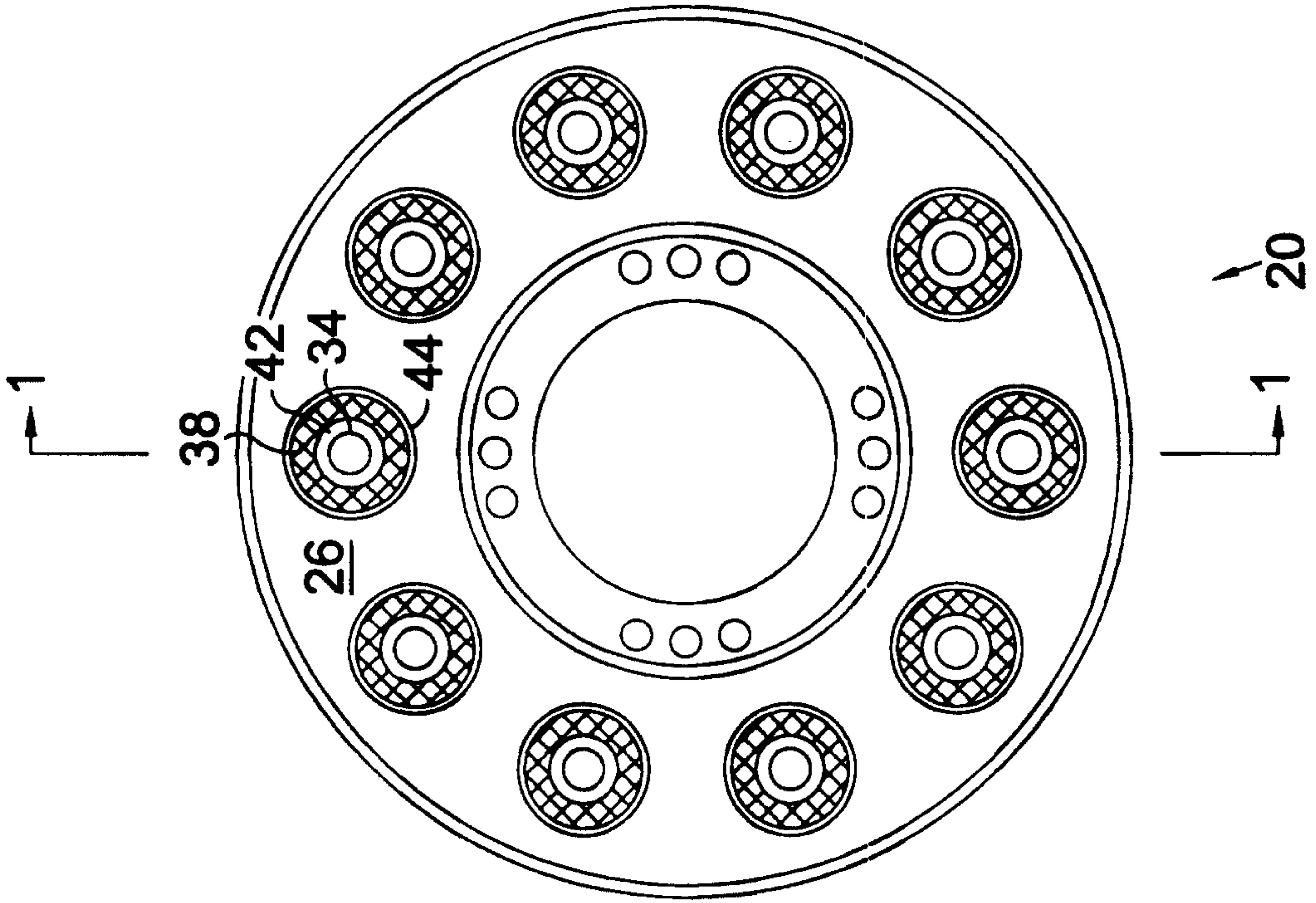

Fig. 2

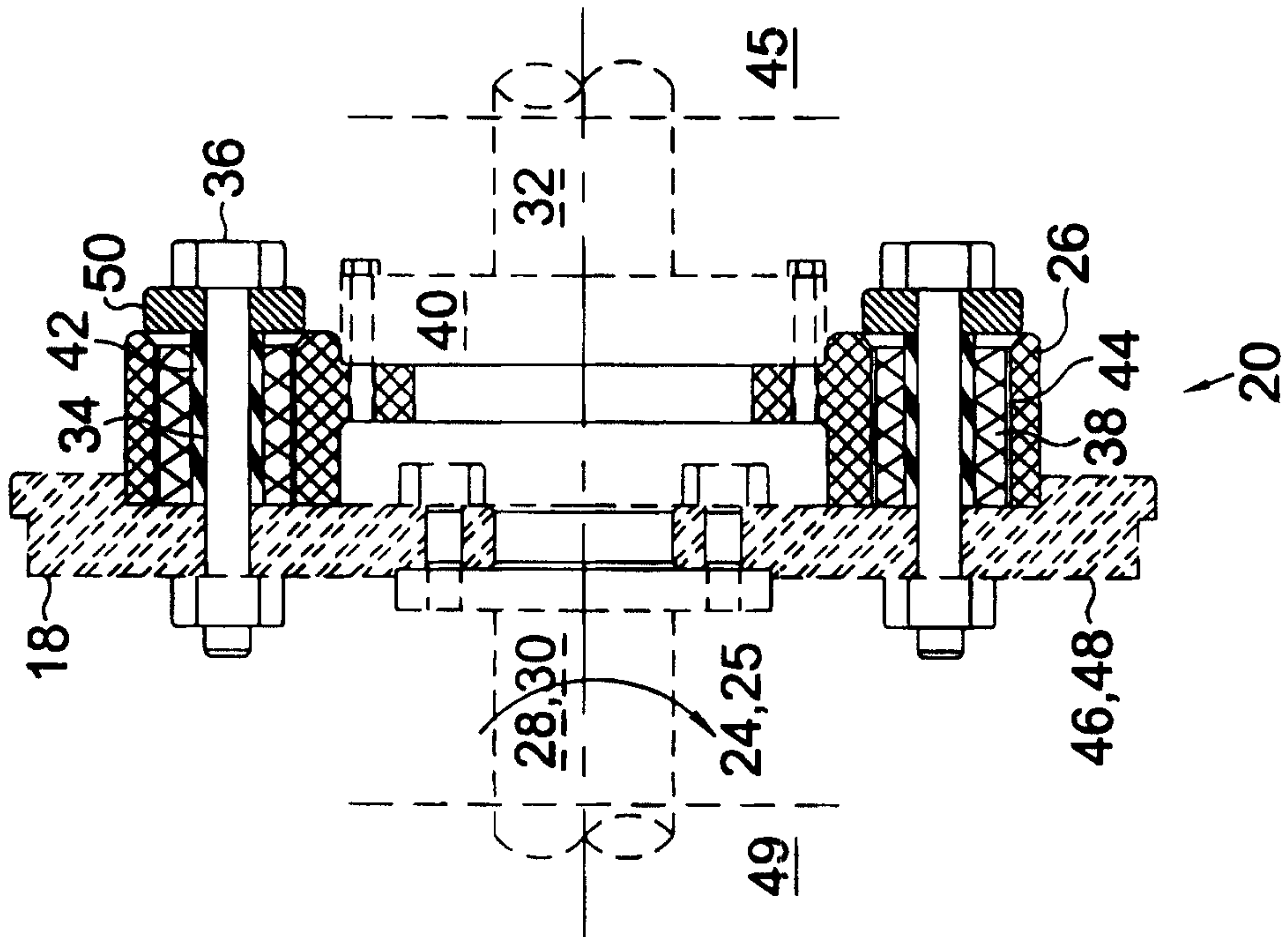

Fig. 1

