



- (51) International Patent Classification:
G06F 15/16 (2006.01) *B65D 85/86* (2006.01)
- (21) International Application Number:
PCT/US2013/027297
- (22) International Filing Date:
22 February 2013 (22.02.2013)
- (25) Filing Language:
English
- (26) Publication Language:
English
- (30) Priority Data:

61/601,722	22 February 2012 (22.02.2012)	US
61/671,572	13 July 2012 (13.07.2012)	US
61/712,136	10 October 2012 (10.10.2012)	US
13/734,871	4 January 2013 (04.01.2013)	US
- (71) Applicant: **SNIK LLC** [US/US]; 1119 Keith Avenue, Berkeley, California 94708 (US).
- (72) Inventor: **HONEYCUTT, Rob**; 1119 Keith Avenue, Berkeley, California 94708 (US).
- (74) Agent: **OWENS, Jonathan O.**; 162 North Wolfe Road, Sunnyvale, California 94086 (US).
- (81) Designated States (*unless otherwise indicated, for every kind of national protection available*): AE, AG, AL, AM, AO, AT, AU, AZ, BA, BB, BG, BH, BN, BR, BW, BY,

BZ, CA, CH, CL, CN, CO, CR, CU, CZ, DE, DK, DM, DO, DZ, EC, EE, EG, ES, FI, GB, GD, GE, GH, GM, GT, HN, HR, HU, ID, IL, IN, IS, JP, KE, KG, KM, KN, KP, KR, KZ, LA, LC, LK, LR, LS, LT, LU, LY, MA, MD, ME, MG, MK, MN, MW, MX, MY, MZ, NA, NG, NI, NO, NZ, OM, PA, PE, PG, PH, PL, PT, QA, RO, RS, RU, RW, SC, SD, SE, SG, SK, SL, SM, ST, SV, SY, TH, TJ, TM, TN, TR, TT, TZ, UA, UG, US, UZ, VC, VN, ZA, ZM, ZW.

- (84) Designated States (*unless otherwise indicated, for every kind of regional protection available*): ARIPO (BW, GH, GM, KE, LR, LS, MW, MZ, NA, RW, SD, SL, SZ, TZ, UG, ZM, ZW), Eurasian (AM, AZ, BY, KG, KZ, RU, TJ, TM), European (AL, AT, BE, BG, CH, CY, CZ, DE, DK, EE, ES, FI, FR, GB, GR, HR, HU, IE, IS, IT, LT, LU, LV, MC, MK, MT, NL, NO, PL, PT, RO, RS, SE, SI, SK, SM, TR), OAPI (BF, BJ, CF, CG, CI, CM, GA, GN, GQ, GW, ML, MR, NE, SN, TD, TG).

- Published:**
- with international search report (Art. 21(3))
 - before the expiration of the time limit for amending the claims and to be republished in the event of receipt of amendments (Rule 48.2(h))

(54) Title: MAGNETIC EARPHONES HOLDER

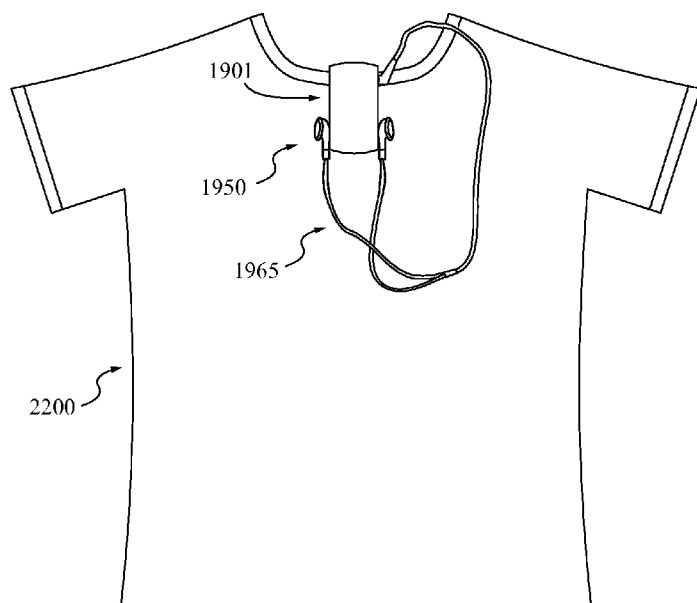

(57) Abstract: An earphones holder is used to affix a headset to clothing and/or other items. The earphones holder comprises a magnet which removably couples with a magnetically attractable portion of a set of earphones. In some embodiments, the earphones holder further comprises an electronic device controller which controls the operation of an electronic device. The controller is configured to send a signal to an electronic device activation circuit which operates the electronic device based upon a coupling status of the earbuds with the one or more magnetically attractable surfaces of the earphones holder body. In some embodiments, the electronic device controller controls the operation of an electronic device. The controller is configured to send a signal to an electronic device activation circuit which operates the electronic in a manner dependent upon a signal from the holder body.



MAGNETIC EARPHONES HOLDERRELATED APPLICATIONS

This Patent Application claims priority under 35 U.S.C. 119(e) to the co-pending U.S. provisional patent application, Application No. 61/601,722, filed on February 22, 2012, and entitled “**MAGNETIC EARPHONES HOLDER**,” the co-pending U.S. provisional patent application, Application No. 61/671,572, filed on July 13, 2012, and entitled “**MAGNETIC EARPHONES HOLDER**,” and the co-pending U.S. provisional patent application, Application No. 61/712,136, filed on October 10, 2012, and entitled “**MAGNETIC EARPHONES HOLDER**.” The co-pending U.S. provisional patent application, Application No. 61/601,722, filed on February 22, 2012, and entitled “**MAGNETIC EARPHONES HOLDER**,” the co-pending U.S. provisional patent application, Application No. 61/671,572, filed on July 13, 2012, and entitled “**MAGNETIC EARPHONES HOLDER**,” and the co-pending U.S. provisional patent application, Application No. 61/712,136, filed on October 10, 2012, and entitled “**MAGNETIC EARPHONES HOLDER**” are all also hereby incorporated by reference.

FIELD OF THE INVENTION

The present invention relates to earphone holders. More particularly, the present invention relates to a magnetic earphone holder used to hold a set of earphones.

BACKGROUND OF THE INVENTION

Headset cords transmit signals from a source device, such as a music player or cell phone, to earphones being worn by a user. Although these cords are typically flexible and can be maneuvered out of the way by the user, such manipulation by the user can be inconvenient, and often inefficient, as the cords regularly find their way back into an undesired location. Additionally, if not secured when not being used the earphones often hang loose in an undesired and inconvenient location where they may be snagged or become tangled. Further, earphones are often moved back and forth from the ears of a user where they are transmitting a signal from the source device to the stored position as the user completes tasks and moves around.

SUMMARY OF THE INVENTION

The present application is directed toward an earphones holder used to affix a headset to clothing and/or other items. Any set of earphones is able to be affixed, including a headset for an iPod, iPhone, or any other similar cell phone or MP3 or music player. The earphones holder comprises a magnet which removably couples with a magnetically attractable portion of a set of earphones or an added magnet feature built into or onto the earbud or cord or any feature of the earbud or cord. The magnet is able to be designed into or molded into a variety of items, including the handle of a zipper, a buckle, and an item that can be sewn to, pinned to, or clipped to clothing, bags and other items. In some embodiments, the earphones holder body further comprises an electronic device controller which controls the operation of an electronic device. The controller is configured to send a signal to an electronic device activation circuit which activates the electronic device when the earphones are decoupled from the one or more magnetically attractable surfaces of the earphones holder body and deactivates the electronic device when the earphones are coupled with the one or more magnetically attractable surfaces of the earphones holder body. In further embodiments, the electronic device controller which controls the operation of an electronic device. Particularly, the controller is configured to send a signal to an electronic device activation circuit which operates the electronic in a manner dependent upon a signal from the holder body.

In one aspect, a system for holding a set of earphones comprises a holder body comprising one or more magnets and a set of earphones comprising a magnetically attractable surface for removably coupling with the one or more magnets. In some embodiments, the holder body is a closure mechanism that releasably couples a first portion of an article to a second portion of the article. In further embodiments, the holder body is one or more of snaps, a button, a releasable clip, zipper, and a hook and loop fastening system. In still further embodiments, the holder body is an accessory item comprising one or more of a necklace, a broach, a pair of earrings, a bracelet and a sunglass lanyard. In some embodiments, the magnetically attractable surface is non-removable. In further embodiments, the magnetically attractable surface is removable. In some embodiments, the system further comprises one or more additional magnets. In some embodiments, the system further comprises one or more grooves for releasably holding a cord of the set of earphones. In some embodiments, the magnetically attractable surface is attached to the cord of the earphones.

In another aspect, an earphones holder comprises a holder body and one or more magnetically attractable surfaces. In some embodiments, the holder body comprises a zipper puller, a snap fastener, an adornment, a buckle attachment, or an item of jewelry. In some embodiments, the one or more magnetically attractable surfaces comprises one or more magnets. In further embodiments, the one or more magnetically attractable surfaces are configured for removably coupling with a metal part of an earbud. In some embodiments, the one or more magnetically surfaces are built into or embedded within the body. In some embodiments, the holder body comprises one or more grooves for releasably holding a cord of a set of earphones.

In a further aspect, a method of securing a set of earphones comprises coupling a magnetically attractable surface to a set of earphones and coupling the magnetically attractable surface to a magnet coupled to an additional article in order to secure the earphones. In some embodiments, the additional article comprises a zipper puller, a snap fastener, an adornment, a buckle attachment, or an item of jewelry. In further embodiments, the additional article is an accessory item comprising one or more of a necklace, a broach, a pair of earrings, a bracelet and a sunglass lanyard. In some embodiments, the one or more magnetically attractable surfaces comprises one or more magnets. In some embodiments, the one or more magnetically surfaces are built into or embedded within the additional article. In further embodiments, the additional article comprises one or more grooves for releasably holding a cord of a set of earphones.

An earphones holder comprises a holder body, one or more magnetically attractable surfaces attached to the holder body, an earbud engagement detector and an electronic device controller for controlling an electronic device coupled to the earphones. In some embodiments, a magnet of the earphones removably couples with the one or more magnetically attractable surfaces. In some embodiments, the magnetically attractable surface comprises one or more magnets and removably couples with a metal portion of the earphones. In further embodiments, the electronic device controller is configured to activate the electronic device when the earphones are decoupled from the holder body. In still further embodiments, the electronic device controller is configured to deactivate the electronic device when the earphones are coupled with the holder body. In some embodiments, the earphones holder body comprises a mechanism for attaching the earphones holder to an additional article. In some of these embodiments, the mechanism is a clip. In some embodiments, the earphones holder body comprises a zipper puller, a snap fastener, an adornment, a buckle attachment, or an item of jewelry. In some embodiments, the holder body comprises one or

more recesses for removably coupling with a body of the earphones. In some embodiments, the earphones holder further comprises a groove for releasably receiving a cord of the set of headphones.

In another aspect, a system for holding a set of earphones comprises an earphones holder body comprising a groove for holding a headset cord, one or more magnetically attractable surfaces, an electronic device controller, an earbud engagement detector and a set of earphones comprising one or more magnets coupled to the earphones. In some embodiments, the one or more magnetically attractable surfaces comprise one or more magnets. In some embodiments, the electronic device controller is configured to activate and/or deactivate an electronic device by sending a signal to an electronic device activation circuit. In some embodiments, the electronic device controller sends a signal to the electronic device activation circuit to activate the electronic device when the earphones are decoupled from the one or more magnetically attractable surfaces of the earphones holder body. In further embodiments, the electronic device controller sends a signal to the electronic device activation circuit to deactivate the electronic device when the earphones are coupled with the one or more magnetically attractable surfaces of the earphones holder body. In some embodiments, the holder body further comprises a mechanism for attaching to an additional article. In some of these embodiments, the mechanism is a clip. In some embodiments, the holder body comprises a zipper puller, a snap fastener, an adornment, a buckle attachment, or an item of jewelry. In further embodiments, the holder body comprises an accessory item comprising one or more of a necklace, a broach, a pair of earrings, a bracelet and a sunglass lanyard. In some embodiments, the holder body further comprises one or more recesses for removably coupling with a body of the earphones.

In a further aspect, a method of operating an electronic device comprises detecting an engagement status of an earbud, sending a signal to an electronic device based upon the engagement status of the earbud and operating the electronic device based upon the engagement status of the earbud. In some embodiments, the electronic device is activated. In further embodiments, the electronic device is deactivated.

A system for holding a set of earphones comprises a holder body, one or more magnetically attractable surfaces attached to the holder body for removably coupling with a set of earphones, a touch sensor, a touch sensor detector and an electronic device controller for controlling an electronic device. In some embodiments, the system wirelessly communicates with the electronic device. In some embodiments, the system further comprising an earbud engagement detector. In some embodiments, the touch sensor detector

receives a signal from the touch sensor and sends a signal to the electronic device controller. In some of these embodiments, the touch sensor detector sends a signal to the electronic device controller that the touch sensor has been tapped, double-tapped, or swiped. Particularly, the electronic device controller sends a signal to an electronic device to operate the electronic device based upon the signal from the touch sensor detector. In some embodiments, the touch sensor detector sends a signal to the electronic device to activate or deactivate the electronic device.

In another aspect, an earphones holder for communicating with an electronic device comprises an earphones holder body comprising a touch sensor and one or more magnetically attractable surfaces for removably coupling with a set of earphones, wherein the touch sensor controls an electronic device coupled to the earphones holder. In some embodiments, the set of earphones is coupled to an earphones jack of the earphones holder. In some embodiments, the electronic device is wirelessly coupled to the earphones holder. In further embodiments, the earphones holder comprises an earbud engagement detector. In some embodiments, the touch sensor is tapped, double-tapped, or swiped in order to control the electronic device. In some embodiments, the earphones holder further comprises an attachment mechanism for attaching to an additional article. In some of these embodiments, the attachment mechanism is a clip.

In another aspect, a method of operating an electronic device comprises touching a touch sensor located on an earphones holder body comprising one or more magnets for removably coupling with a set of earphones, sending a signal to a touch sensor detector and sending a signal to an electronic device based upon the signal sent to the touch sensor detector. In some embodiments, the touch sensor is tapped, double-tapped, or swiped. In some embodiments, the touch sensor detector receives a signal from the touch sensor and sends a signal to an electronic device controller. In further embodiments, the electronic device is operated by touching the touch sensor.

BRIEF DESCRIPTION OF THE DRAWINGS

FIG. 1 illustrates an embodiment of an earphones holder having a magnet built into the body of a zipper puller in accordance with the principles of the present invention.

FIGS. 2A-B illustrate an embodiment of an earphones holder having a magnet built into the surface of a plastic shirt snap in accordance with the principles of the present invention.

FIGS. 3A-3D illustrate an embodiment of an earphones holder having a magnet built into a body of an adornment in accordance with some embodiments.

FIG. 4 illustrates an embodiment of an earphones holder having a magnet built into a zipper puller in accordance with some embodiments.

FIGS. 5A and 5B illustrate an embodiment of an earphones holder having a magnet built into a body coupled with a sunglass lanyard in accordance with some embodiments.

FIGS. 5C – 5E illustrate an embodiment of an earphones holder having a magnet built into a body coupled with a pair of sunglasses in accordance with some embodiments.

FIGS. 5F and 5G illustrate an embodiment of an earphones holder having a magnet built into a body of a pair of sunglasses in accordance with some embodiments.

FIGS. 6A and 6B illustrate an embodiment of an earphones holder having a magnet built onto the front face of a side squeeze buckle used on bags and packs in accordance with the principles of the present invention.

FIGS. 6C and 6D illustrate an embodiment of an earphones holder having a magnet built into a releasable clip coupled to a sports helmet in accordance with some embodiments.

FIGS. 7A and 7B illustrate an embodiment of an earphones holder having a magnet built into a body in accordance with some embodiments.

FIGS. 8A and 8B illustrate an embodiment of an earphones holder having a magnet built into a piece of jewelry in accordance with some embodiments.

FIG. 9 illustrates an embodiment of an earphones holder having a magnet built into an identifying surface in accordance with some embodiments.

FIG. 10A illustrates an embodiment of an earphones holder having a magnet and a groove built into a zipper puller in accordance with some embodiments.

FIG. 10B shows a close-up view of a magnetically attractable surface for removably coupling with a pair of earphones in accordance with some embodiments.

FIG. 11 illustrates a magnetic earphones and cord holding system in accordance with some embodiments.

FIGS. 12A and 12B illustrate a magnetic earphones and cord holding system in accordance with some embodiments.

FIGS. 13 illustrates a schematic view showing the components of a magnetic earphones and cord holding system in accordance with some embodiments.

FIG. 14 illustrates a method of activating and/or deactivating an electronic device in accordance with some embodiments.

FIG. 15 illustrates a magnetic earphones holding system in accordance with some embodiments.

FIG. 16 illustrates a magnetic earphones holding system in accordance with some embodiments.

FIG. 17 illustrates a magnetic earphones holding system in accordance with some embodiments.

FIG. 18 illustrates a magnetic earphones holding system in accordance with some embodiments.

FIGS. 19A-19E illustrate a magnetic earphones holding system in accordance with some embodiments.

FIG. 20 illustrates a magnetic earphones holding system in accordance with some embodiments.

FIG. 21 illustrates a block diagram of a magnetic earphones holding system in accordance with some embodiments.

FIG. 22 illustrates a magnetic earphones holding system in accordance with some embodiments.

FIG. 23 illustrates a schematic view showing the components of a magnetic earphones and cord holding system in accordance with some embodiments.

FIG. 24 illustrates a method of activating and/or deactivating an electronic device in accordance with some embodiments.

DETAILED DESCRIPTION OF THE INVENTION

The description below concerns several embodiments of the invention. The discussion references the illustrated preferred embodiment. However, the scope of the present invention is not limited to either the illustrated embodiment, nor is it limited to those discussed, to the contrary, the scope should be interpreted as broadly as possible based on the language of the Claims section of this document.

This disclosure provides several embodiments of the present invention. It is contemplated that any features from any embodiment can be combined with any features from any other embodiment. In this fashion, hybrid configurations of the illustrated embodiments are well within the scope of the present invention.

Referring now to FIG. 1, a first embodiment of an earphones holder 100 is depicted therein. The earphones holder 100 comprises a magnet 110 embedded or molded into a body 115 of a zipper puller 150. The zipper puller 150 is configured to be coupled to a bag or an

item of clothing, such as a jacket or shirt. In some embodiments, the body 115 is configured to act as a closure mechanism capable of releasably coupling a first portion of the bag or item of clothing to a second portion of the bag or article of clothing. For example, in some embodiments, the body 115 comprises a channel (not shown) formed in opposing sidewalls in order to receive and releasably couple together zipper tracks of the bag or item of clothing. In some embodiments, a puller 140 is coupled to the body 115 in order to facilitate the translation of the body 115 along the portions of the bag or item of clothing to which it is attached.

The magnet 110 is molded or otherwise built into the body 115. In some embodiments, the magnet 110 is encased or embedded within a plastic over mold which surrounds the puller 140. In some embodiments, one or more additional magnets are coupled with the body 115. The magnet 110 is configured to receive and releasably secure a set of earphones 175. As shown in FIG. 1, in some embodiments, the magnet 110 removably couples with the magnetically attractable parts of an earbud of the earphones 175. In some embodiments, the earphones 175 and/or the cord 165 comprises a magnet or magnetically attractable surface, which removably couples with the magnet 110. The earphones holder 100 holds a set of earphones 175 connected to the user's Ipod or other electronic device.

FIGS. 2A-B illustrate an embodiment of an earphones holder 200 with a magnet molded into the surface of a plastic or metal snap fastener in accordance with further embodiments. It is contemplated that the snap fastener is capable of being used on a shirt 260, as shown in FIG. 2B, or on another item of clothing or a bag.

The shirt snap comprises a male snap 235 and a female snap 245 that are configured to releasably couple to one another. For example, in some embodiments, the male snap 235 comprises a stud 240 that is configured to fit securely into an aperture in the female snap 245. The perimeter of the aperture is defined by the inner circumference of the socket lip 250 and the base 255 of the female snap 245. In some embodiments, the socket lip 250 extends farther towards the aperture than the base 255, and the end of the stud 240 has a larger diameter than the base of the stud 240. In this configuration, the end of the stud 240, when inserted into the aperture, snaps into place, and is secured from accidental removal by the socket lip 250.

The shirt snap comprises a magnet 210. In some embodiments, the magnet 210 is embedded within the male snap 235 or the female snap 245. In other embodiments, the magnet 210 is a distinct component that is attached to the male snap 235 or the female snap 245. For example, FIG. 2A shows an exploded view of the headset holder 200 with the magnet 210 separated from the male snap 235. The magnet 210 comprises a body 215 that fits

securely into an aperture in the male snap 235. In some embodiments, the magnet 210 (as a part of the snap fastener) is configured to act as a closure mechanism capable of releasably coupling a first portion of an item of clothing or a bag to a second portion of the article of clothing or bag.

The magnet 210 is molded or otherwise built into the body 215. The magnet 210 is configured to receive and releasably secure a set of earphones. In some embodiments, the magnet 210 removably couples with the magnetically attractable parts of the earphones 275 (FIG. 2B). In some embodiments, the earphones 275 and/or the cord 265 comprises a magnet or magnetically attractable surface, which removably couples with the magnet 210. FIG. 2B shows the headset holder 200 in use as a shirt snap fastener on a user's shirt 260. The earphones holder 200 holds a set of earphones 275 connected to the user's Ipod 270.

FIGS. 3A-D illustrate earphone holders 300 and 305 having a magnet 310 molded into an adornment in accordance with some embodiments. In some embodiments, the adornment is an ornamental accessory having an aesthetic characteristic unrelated to its functional structure, such as the star shape in FIGS. 3A-B and the moon shape in FIGS. 3C-D. The buttons and zippers shown in the previous figures would not constitute an adornment since they do not have an aesthetic characteristic that is unrelated to their functional structure. However, if they were modified to have a certain aesthetic shape that was completely unrelated to their functionality, then they could be considered an adornment.

The adornment comprises a body 315 that is configured to be releasably secured to a bag or an article of clothing, such as shirt 360. In some embodiments, the body 315 comprises a pin 335 extending from its base. The pin 335 is configured to penetrate the bag or item of clothing. In some embodiments, one or more flanges 340 are disposed proximate the end of the pin 335 to facilitate the attachment of the adornment to the bag or article of clothing. In some embodiments, a clasp 345 having releases 350 is provided along with the adornment in order to provide a secure attachment of the adornment to the bag or article of clothing.

The magnet 310 is molded or otherwise built into the body 315. The magnet 310 is configured to receive and releasably secure a set of earphones. In some embodiments, the magnet 310 removably couples with the magnetically attractable parts of the earphones 375 (FIG. 3B). In some embodiments, the earphones 375 and/or the cord 365 comprises a magnet or magnetically attractable surface, which removably couples with the magnet 310. FIG. 3A shows the headset holder 300 attached to a user's shirt 360. The earphones holder 300 holds a set of earphones 375 connected to the user's Ipod 370.

Although FIG. 3D illustrates the body using a pin for attachment, it is contemplated that the body can employ other means for releasably securing itself to a bag or an article of clothing. For example, in some embodiments the body utilizes a magnetic attachment in accordance with the principles of the present invention.

FIG. 4 illustrates an embodiment of an earphones holder 400 having a magnet molded into a body configured to be coupled to a zipper head in accordance with further embodiments.

As shown in FIG. 4, the body 415 is coupled to the zipper head 450. The earphones holder 400 comprises a puller 440 which is coupled to the body 415. As shown in FIG. 4, in some embodiments, the puller 440 is a cord which passes through the center of the body 415. In some embodiments the puller 440 is a cord which couples the body 415 with an opening 480. In some embodiments the body 415 comprises one or more of wood, glass, and metal.

The body 415 comprises a magnet 410. In some embodiments, the magnet 410 is embedded within the body 415. In other embodiments, the magnet 410 is a distinct component that is attached to the body 415. As shown within FIG. 4, the magnet 410 is molded or otherwise built into the body 415. The magnet 410 is configured to receive and releasably secure a set of earphones. In some embodiments, the magnet 410 removably couples with the magnetically attractable parts of the earphones 475. In some embodiments, as shown in FIG. 4, the earphones 475 also comprise a magnet or magnetically attractable surface 425, which removably couples with the magnet 410. In these embodiments, the magnet or magnetically attractable surface 425 is able to be a component of the earphones 475 or the headset cord 465. In some embodiments, the magnet or magnetically attractable surface 425 is slidable along the earphones 475 or the headset cord 465. However, as will be apparent to someone of ordinary skill in the art, the magnet or magnetically attractable surface 425 is able to be fixedly or removably connected to the earphones 475 or the headset cord 465. As also shown in FIG. 4, in some embodiments, the earphones holder 400 comprises one or more additional magnets 410'. In some embodiments, a user is able to removably couple each side of the headset cord 465 or the earphones 475 with a corresponding magnet. Alternatively, in some embodiments, a user is able to couple both sides of the headset cord 465 or earphones 475 with only one of the magnets.

FIGS. 5A – 5E illustrate an earphone holder 500 in accordance with further embodiments. As shown in FIGS. 5A and 5B, in some embodiments, the earphone holder 500 comprises a body 515 having a magnet 510 molded into it. The body 515 is configured to be coupled to a lanyard for sun or prescription glasses. In some embodiments, the lanyard 570

passes through an opening 580 within the body 515. However, the body 515 is able to couple with the lanyard through a clip or any other mechanism as known in the art. As shown in FIGS. 5A and 5B, each side of the lanyard comprises a body 515 of a headset cord holder 500. However, in some embodiments, the earphone holder 500 is only coupled to one side of the lanyard 570. In some embodiments, the body 515 of the earphone holder 500 comprises one or more of molded plastic, hard plastic, foam and rubber. In some embodiments, the body 510 of the headset cord holder comprises one or more of wood, glass, and metal.

As shown in FIGS. 5C-5E, in some embodiments, the body 515' and the body 515" is configured to be removably coupled with a glasses frame 501. In some embodiments, an opening 580 within the body 515' and the body 515" is slid onto an ear piece 503 of the glasses frame 501. Accordingly, a user is able to slide the body 515' and the body 515" until a desired configuration along the ear piece 503 is found. As will be apparent to someone of ordinary skill in the art, the body 515' and the body 515" is able to couple with the glasses frame 501 by any mechanism as known in the art. For example, in some embodiments, the body 515' and the body 515" couples with the glasses frame 501 by one or more of a hook and loop fastening system and a clip. The glasses frame 501 is able to comprise sun and prescription glasses or a combination of the two. In some embodiments, the body 515' and the body 515" of the earphones holder comprises one or more of molded plastic, hard plastic, foam and rubber. In some embodiments, the body 515' and the body 515" of the earphones holder comprises one or more of wood, glass, and metal.

As shown in FIG. 5D, in some embodiments, the magnet 510 is oriented vertically along the body 515'. Alternatively, as shown within FIG. 5E, in some embodiments, the magnet 510 is oriented horizontally along the body 515". In some embodiments, the body 515' and 515" comprises one or more additional magnets 510'.

FIGS. 5F and 5G show an earphone holder comprising a body and a magnet within the body that directly receives and releasably secures a headset cord. In some embodiments, the magnet 510 is built into the glasses frame 501.

As shown within FIGS. 5F and 5G, in some embodiments the magnet 510 is built into the top of an ear piece 503 of the glasses frame 501. Alternatively, in some embodiments, as shown in FIGS. 5F and 5G, in some embodiments, the magnet 510 is built into a side of the earpiece 503 of the glasses frame 501. In some embodiments, the magnet 510 is oriented vertically along the ear piece 503. Alternatively, in some embodiments, the magnet 510 is

oriented horizontally along the ear piece 503. Particularly, the magnet 510 is able to be located at any position along the ear piece 503. In some embodiments, the glasses frame 501 comprises one or more additional magnets.

As further shown within FIGS. 5A-5G, the magnets are configured to receive and releasably secure a set of earphones. In some embodiments, the magnet 510 removably couples with the magnetically attractable parts of the earphones 575. In some embodiments, as shown in FIG. 5G, the earphones 575 also comprises a magnet or magnetically attractable surface 525, which removably couples with the magnet 510. In these embodiments, the magnet or magnetically attractable surface 525 is able to be a component of the earphones 575 or the headset cord 565. In some embodiments, the magnet or magnetically attractable surface 525 is slidable along the earphones 575 or the headset cord 565. However, as will be apparent to someone of ordinary skill in the art, the magnet or magnetically attractable surface 525 is able to be fixedly connected to the earphones 575 or the headset cord 565. In some embodiments, a user is able to removably couple each side of the headset cord 565 or the earphones 575 with a corresponding magnet. Alternatively, in some embodiments, a user is able to couple both sides of the headset cord 565 or earphones 575 with only one of the magnets.

FIGS. 6A-B illustrate one embodiment of an earphones holder 600 having a magnet molded onto the front face of a side squeeze buckle used on bags and packs in accordance with some embodiments. FIGS. 6A and 6B show a plan view and a side view of the cord holder 600, respectively.

The side squeeze buckle comprises a female buckle end 615 coupled to a buckle strap or webbing 640 and a male buckle end 635 coupled to a buckle strap or webbing 645. The female buckle end 615 is configured to receive and releasably hold the male buckle end 635. In some embodiments, either the female buckle end 615 or the male buckle end 635 comprises a magnet 610. In some embodiments, the magnet 610 protrudes from either the female buckle end 615, as seen in FIGS. 6A and 6B, or the male buckle end 635. In some embodiments, the magnet 610 does not protrude from the rest of the buckle end, but rather is flush with the rest of the buckle end. Additionally, in some embodiments, the magnet 610 is integrally formed with the buckle end, while in other embodiments, the body is a separate component that is attached to the buckle end. In some embodiments, the earphones holder 600 is configured to act as a closure mechanism capable of releasably coupling a first strap, and any item to which the first strap is attached, to a second strap, and any item to which the second strap is attached. For example, in some embodiments, the magnet is part of a female

buckle end 615 that is coupled to a first portion of a bag via a strap 640. The female buckle end 615 mates with a male buckle end 635. The male buckle end 635 is coupled to a second portion of the bag via a strap 645.

The magnet 610 is configured to receive and releasably secure a set of earphones. In some embodiments, the magnet 610 removably couples with the magnetically attractable parts of the earphones. In some embodiments, the earphones also comprise a magnet or magnetically attractable surface, which removably couples with the magnet 610. In these embodiments, the magnet or magnetically attractable surface is able to be a component of the earphones or the headset cord. In some embodiments, the magnet or magnetically attractable surface is slidable along the earphones or the headset cord. However, as will be apparent to someone of ordinary skill in the art, the magnet or magnetically attractable surface is able to be fixedly connected to the earphones or the headset cord. In some embodiments, the earphones holder 600 comprises one or more additional magnets. In some embodiments, a user is able to removably couple each side of the headset cord or the earphones with a corresponding magnet. Alternatively, in some embodiments, a user is able to couple both sides of the headset cord or earphones with only one of the magnets.

FIGS. 6C and 6D illustrate a headset cord holder 600 in accordance with yet further embodiments. As shown in FIGS. 6C and 6D, the headset cord holder 600 comprises a body having a magnet 610 molded into the front face of a releasable clip or side squeeze buckle as described in relation to FIGS. 6A and 6B. The releasable clip is configured to be attached to a sports helmet.

Each end of the releasable clip 615, 635 is coupled by a strap 645, 640 to a sports helmet. As shown in FIG. 6D, the releasable clip is coupled to a bicycle helmet 660. However, the releasable clip is able to be coupled to any sports helmet as known in the art. For example, in some embodiments the releasable clip is coupled to one or more of a skiing helmet, bicycle helmet, motorcycle helmet or other sports helmet.

A magnet 610 is built or otherwise embedded within the releasable clip. The magnet 610 is configured to receive and releasably secure a set of earphones. In some embodiments, the magnet 610 removably couples with the magnetically attractable parts of the earphones. In some embodiments, the earphones also comprises a magnet or magnetically attractable surface, which removably couples with the magnet 610. The magnet 610 is configured to receive and releasably secure a set of earphones. In some embodiments, the magnet 610 removably couples with the magnetically attractable parts of the earphones. In some embodiments, the earphones also comprise a magnet or magnetically attractable surface,

which removably couples with the magnet 610. In these embodiments, the magnet or magnetically attractable surface is able to be a component of the earphones or the headset cord. In some embodiments, the magnet or magnetically attractable surface is slidable along the earphones or the headset cord. However, as will be apparent to someone of ordinary skill in the art, the magnet or magnetically attractable surface is able to be fixedly connected to the earphones or the headset cord. In some embodiments, the earphones holder 600 comprises one or more additional magnets. In some embodiments, a user is able removably couple each side of the headset cord or the earphones with a corresponding magnet. Alternatively, in some embodiments, a user is able to couple both sides of the headset cord or earphones with only one of the magnets.

FIGS. 7A and 7B illustrate a headset cord holder 700 in accordance with further embodiments.

As shown in FIGS. 7A and 7B, a body 715 comprising a magnet 710 is coupled to a sternum strap 720 of a backpack 705. In some embodiments, the magnet 710 is coupled to an arm strap of a backpack 705. However, the body 715 is able to couple to any portion of the backpack 705 as known in the art. In some embodiments, the body 715 removably couples with the sternum strap 715 of the backpack 705. In some embodiments, the body 715 removably couples with the sternum strap 715 by one or more of a hook and loop fastening system and snaps. However, the body 715 is able to removably couple with the backpack 705 by any mechanism as known in the art. In some embodiments, the body 715 is able to additionally couple with one or more of a lumbar pack, a sports bag, and an arm band.

As shown within FIGS. 7A and 7B, the magnet 710 is configured to receive and releasably secure a set of earphones. In some embodiments, the magnet 710 removably couples with the magnetically attractable parts of the earphones. In some embodiments, the earphones also comprises a magnet or magnetically attractable surface, which removably couples with the magnet 710. In these embodiments, the magnet or magnetically attractable surface is able to be a component of the earphones or the headset cord. In some embodiments, the magnet or magnetically attractable surface is slidable along the the earphones or the headset cord. However, as will be apparent to someone of ordinary skill in the art, the magnet or magnetically attractable surface is able to be fixedly connected to the earphones or the headset cord. In some embodiments, the earphones holder 700 comprises one or more additional magnets. In some embodiments, a user is able removably couple each side of the headset cord or the earphones with a corresponding magnet. Alternatively, in

some embodiments, a user is able to couple both sides of the headset cord or earphones with only one of the magnets.

FIGS. 8A and 8B illustrate an earphones holder 800 in accordance with some embodiments. The headset cord holder 800 comprises a body 815 having a magnet 810 molded or built into the body which is a portion of a piece of jewelry 870.

In some embodiments, the portion of jewelry is configured to be coupled to at least an additional article. For example, as shown in FIGS. 8A and 8B, the body 815 comprises a bead of jewelry 860 in a strand of beads comprising a necklace 870. In some embodiments, the piece of jewelry is one or more of a broach, earrings, bracelet or sunglass lanyard. However, the body is able to be molded or built into any piece of jewelry as known in the art. Alternatively, in some embodiments one or more additional magnets are able to be molded in to the body or other portion of the piece of jewelry.

As shown within FIGS. 8A and 8B, the magnet 810 is configured to receive and releasably secure a set of earphones. In some embodiments, the magnet 810 removably couples with the magnetically attractable parts of the earphones. In some embodiments, the earphones also comprises a magnet or magnetically attractable surface, which removably couples with the magnet 810. In these embodiments, the magnet or magnetically attractable surface is able to be a component of the earphones or the headset cord. In some embodiments, the magnet or magnetically attractable surface is slidable along the earphones or the headset cord. However, as will be apparent to someone of ordinary skill in the art, the magnet or magnetically attractable surface is able to be fixedly connected to the earphones or the headset cord. In some embodiments, the earphones holder 800 comprises one or more additional magnets. In some embodiments, a user is able to removably couple each side of the headset cord or the earphones with a corresponding magnet. Alternatively, in some embodiments, a user is able to couple both sides of the headset cord or earphones with only one of the magnets.

As described above, in FIGS 8A and 8B, the body 815 comprises a bead of jewelry 860 in a strand of beads comprising a necklace 870. In some embodiments, the piece of jewelry is one or more of a broach, earrings, bracelet or sunglass lanyard. However, the body is able to be molded or built into any piece of jewelry as known in the art. Alternatively, in some embodiments one or more additional magnets is able to be molded in to the body or other portion of the piece of jewelry.

FIG. 9 illustrates an embodiment of an earphones holder having a magnet built into an identifying surface in accordance with some embodiments.

The earphones holder 900 comprises a body 901 having a magnet 910 molded or built into the body 901 which is a portion of an identifying surface 960. The body 901 is configured to be coupled to at least an additional article. In some embodiments, the body 901 comprises one or more of rubber, plastic and metal. The body 901 is configured to attach to an additional article by one or more of stitching, riveting, heat pressing, adhesive attachment, or chemical method. In some embodiments, the body 901 comprises an additional surface 915 which attaches to the additional article.

The magnet 910 is configured to receive and releasably secure a set of earphones. In some embodiments, the magnet 910 removably couples with the magnetically attractable parts of the earphones. In some embodiments, the earphones also comprises a magnet or magnetically attractable surface, which removably couples with the magnet 910. In these embodiments, the magnet or magnetically attractable surface is able to be a component of the earphones or the headset cord. In some embodiments, the magnet or magnetically attractable surface is slidable along the earphones or the headset cord. However, as will be apparent to someone of ordinary skill in the art, the magnet or magnetically attractable surface is able to be fixedly connected to the earphones or the headset cord. In some embodiments, the earphones holder 900 comprises one or more additional magnets. In some embodiments, a user is able to removably couple each side of the headset cord or the earphones with a corresponding magnet. Alternatively, in some embodiments, a user is able to couple both sides of the headset cord or earphones with only one of the magnets.

As described above, the body 901 comprises a portion of an identifying surface 960 and is configured to be coupled to an additional article. Particularly, the identifying surface is able to be coupled to an appropriate article as known in the art. For example, in some embodiments the identifying surface 960 is coupled to a bag or an item of clothing. Alternatively, in some embodiments, the identifying surface 960 is coupled to an accessory item such as a key chain or armband. In some embodiments one or more additional magnets is able to be molded into the body 901 or other portion of the identifying surface 960.

As further shown in Fig. 9, a groove 920 is molded or otherwise built into the body 901. The groove 920 is configured to receive and releasably secure a headset cord. In some embodiments, the groove 920 is defined by a groove wall 930 that surrounds most of the groove 920, leaving only an entry space 935 through which the cord can access the groove 920. In some embodiments, the entry space 935 has a smaller diameter than the groove 920 and the cord, thereby securing the cord within the confines of the groove wall 930 and requiring a significant amount of force for its removal. In some embodiments, portions of the

groove wall 930 are flexible so that as the cord is pushed through the entry space 935, the cord is able to force the groove wall 930 out of its way and temporarily increase the diameter of the entry space 935 so that the cord can pass through the entry space 930 into the groove 920. In some embodiments, the groove wall 930 is substantially rigid, thereby forcing the outer sleeve of the cord to constrict as it passes through the entry space 935 between the ends of the groove wall 930.

By incorporating a magnet and a groove into the surface of the body 901 a user is able to releasably secure a headset cord in the groove 920 while utilizing the earphones and then magnetically secure the earphones to the body 901 when not in use.

FIG. 10A illustrates an embodiment of an earphones holder having a magnet and a groove built into a zipper puller in accordance with some embodiments.

As shown in FIG. 10A, the body 1001 is coupled to the zipper head 1050. The earphones holder 1000 comprises a puller 1040 which is coupled to the body 1001. In some embodiments, the puller 1040 is a cord which passes through the center of the body 1001. In some embodiments, the puller 1040 is a cord which couples the body 1001 with an opening 1080. In some embodiments, the body 1001 comprises one or more of wood, glass, and metal.

The body 1001 comprises a magnet 1010. In some embodiments, the magnet 1010 is embedded within the body 1001. In other embodiments, the magnet 1010 is a distinct component that is attached to the body 1001. As shown within FIG. 10A, the magnet 1010 is molded or otherwise built into the body 1001. The magnet 1010 is configured to receive and releasably secure a set of earphones 1075. In some embodiments, the magnet 1010 removably couples with the magnetically attractable parts of the earphones 1075. In some embodiments, as shown in FIG. 10A, the earphones 1075 comprise a magnet or magnetically attractable surface 1085 coupled to the earphones, which affixes the earbud to the magnet 1010 built into or embedded within the body 1001. In these embodiments, the magnet or magnetically attractable surface 1085 is able to be a component of the earphones 1075 or the headset cord 1065. In some embodiments, the magnet or magnetically attractable surface 1085 snaps or removably couples around the earphones 1075. In some embodiments, the magnet or magnetically attractable surface 1085 is slidable along the earphones 1075 or the headset cord 1065. As will be apparent to someone of ordinary skill in the art, the magnet or magnetically attractable surface 1085 is able to be fixedly or removably connected to the earphones 1075 or the headset cord 1065.

As also shown in FIG. 10A, a groove 1020 is molded or otherwise built into the body 1001. The groove 1020 is configured to receive and releasably secure the headset cord 1065. In some embodiments, the groove 1020 is defined by a groove wall 1030 that surrounds most of the groove 1020, leaving only an entry space through which the cord 1065 can access the groove 1020. In some embodiments, the entry space has a smaller diameter than the groove 1020 and the cord 1065, thereby securing the cord within the confines of the groove wall 1030 and requiring a significant amount of force for its removal. In some embodiments, portions of the groove wall 1030 are flexible so that as the cord is pushed through the entry space, the cord is able to force the groove wall 1030 out of its way and temporarily increase the diameter of the entry space so that the cord can pass through the entry space into the groove 1020. In some embodiments, the groove wall 1030 is substantially rigid, thereby forcing the outer sleeve of the cord to constrict as it passes through the entry space between the ends of the groove wall 1030.

FIG. 10B shows a close-up view of the magnetically attractable surface 1085, in accordance with some embodiments. The magnetically attractable surface 1085 removably couples with the earphones 1075 or the headset cord 1065 in order to removably couple the earphones with the magnet 1010 as described above. As shown within FIG. 10B, the magnetically attractable surface 1085 comprises a substantially circular body that fits around the earphones 1075. In some embodiments, the magnetically attractable surface 1085 is stretchable and stretches to fit over the earphones 1075. In some embodiments, the magnetically attractable surface 1085 comprises a hinge or coupler 1087 which enables the magnetically attractable surface 1085 to be opened and coupled around the earphones 1075. In some embodiments, the magnetically attractable surface 1085 is able to be opened at coupler 1087 and then placed around the earphones 1075 and snap fit back into place. In some embodiments, the magnetically attractable surface 1085 comprises two pieces which are separated in order to removably couple the magnetically attractable surface 1085 with the earphones 1075. Particularly, the magnetically attractable surface 1085 is able to removably couple with the earphones 1075 by any appropriate mechanism as known in the art. Additionally, although the magnetically attractable surface 1085 is shown with a circular body, the magnetically attractable surface is able to comprise any appropriate shape for coupling with the earphones 1075.

In some embodiments, a user is able to place the headset cord 1065 within the groove 1020 and then removably couple the magnet or magnetically attractable surface 1085 of the earphones 1075 with the magnet 1010.

In some embodiments, a shape of the one or more magnets as described above is selected from a set comprising a strip, a ball bearing and a disc. In further embodiments, at least one of the one or more magnets comprise one or more of a neodymium magnet and a ceramic magnet.

In operation, a user places a headset cord within the confines of the groove wall while using the headset to listen to an electronic device. This enables a user to comfortably utilize the headset without becoming entangled within the cord. Then, when not listening to the electronic device, a user places a set of earphones near to the magnet in order to allow the earphones to magnetically attract to and be held by the magnet. This enables the user to place the earphones in a convenient location when using the earphones and also when not in use. By doing so, a user is able to safely secure the earphones rather than letting them dangle where they may become entangled or snagged by the user. Consequently, the earphones holder has the advantage of providing an inexpensive and easy way to hold a headset cord in a comfortable and convenient position while utilizing an electronic device. Accordingly, the headset cord holder described herein has numerous advantages.

Referring now to Figure 11, an embodiment of a magnetic earphones and cord holding system is depicted therein. The magnetic earphones and cord holding system 1100 comprises an earphones holder body 1101 and a set of earphones 1150. The set of earphones 1150 transmits a signal from an electronic device 1105 such as an iPod, iPhone, any other similar cellular phone or smart phone, MP3 or music player, movie player, or other electronic device 1105. As will be apparent to someone of ordinary skill in the art, the set of earphones 1150 is able to transmit a signal from any appropriate electronic device 1105 as known in the art. For example, in some embodiments, the set of earphones 1150 transmits a signal from an electronic media player such as an iPad, smart phone, tablet PC, Mp4 player, or DivX Media format player.

The earphones holder body 1101 comprises a groove 1120 for receiving and releasably securing a headset cord 1165, one or more magnetically attractable surfaces 1110 for removably coupling with one or more magnets 1185 of the set of earphones 1150, and an electronic device controller 1140. In some embodiments, the one or more magnetically attractable surfaces 1110 are magnets. In some of these embodiments, the magnets are neodymium magnets. In further embodiments, the earphones holder body 1101 comprises one or more recesses 1115 for holding an earbud 1175. In some embodiments, the earbud 1175 is press fit into the one or more recesses 1115. In some embodiments, the earphones holder body 1101 comprises a body comprising a zipper puller, a snap fastener, an

adornment, a buckle attachment, or an item of jewelry and a magnet built into or embedded within the body. Particularly, the earphones holder body 1101 is able to comprise a cord holder as described in U.S. Patent Application No. 12/891,510, filed on September 27, 2010 and/or a earphones holder as described in U.S. Provisional Patent Application No. 61/601,722, filed on February 22, 2012, which are both hereby incorporated by reference. In some embodiments, the set of earphones 1150 is a component of a hands free telephone adapter.

The groove 1120 is molded or otherwise built into the earphones body 1101. The groove 1120 is configured to receive and releasably secure a headset cord 1165. In some embodiments, the groove 1120 is defined by a groove wall 1122 that surrounds most of the groove 1120, leaving only an entry space 1124 through which the cord 1165 can access the groove 1120. In some embodiments, the entry space 1135 has a smaller diameter than the groove 1120 and the cord 1165, thereby securing the cord 1165 within the confines of the groove wall 1122 and requiring a significant amount of force for its removal. In some embodiments, portions of the groove wall 1122 are flexible so that as the cord 1165 is pushed through the entry space 1124, the cord 1165 is able to force the groove wall 1122 out of its way and temporarily increase the diameter of the entry space 1135 so that the cord 1165 can pass through the entry space 1124 into the groove 1120. In some embodiments, the groove wall 1122 is substantially rigid, thereby forcing the outer sleeve of the cord 1165 to constrict as it passes through the entry space 1124 between the ends of the groove wall 1122.

By incorporating a magnet and a groove into the surface of the earphones holder body 1101, a user is able to releasably secure a headset cord 1165 in the groove 1120 while utilizing the earphones 1150 and then magnetically secure the earphones 1150 to the earphones holder body 1101 when not in use. The one or more magnetically attractable surfaces 1110 are able to be fixedly or removably connected to the earphones holder body 1101.

As described above, the one or more magnetically attractable surfaces 1110 are configured for removably coupling with the one or more magnets 1185 of the earphones 1150. In some embodiments, when the one or more magnets 1185 are removably coupled with the one or more magnetically attractable surfaces 1110, the body of the earbud 1175 is placed within the one or more recesses 1115. In some embodiments, the one or more recesses 1115 and the body of the earbud 1175 comprise interlocking geometry. In these embodiments, the body of the earbud 1175 is press fit or snap fit into the one or more recesses of the earphones holder body 1101.

The electronic device controller 1140 receives a signal from the earbud engagement detector 1130 and sends a signal to the electronic device activation circuit 1155 based upon the signal received from the earbud engagement detector 1130. The electronic device activation circuit 1155 operates an electronic device 1105 based upon the signal received from the controller 1140. In some embodiments, the earbud engagement detector 1130 sends a signal to the controller 1140 that the one or more magnets 1185 and the earbud 1175 have been decoupled from the earphones holder body 1101. In these embodiments, upon receiving the signal from the earbud engagement detector 1130, the controller 1140 sends a signal to the electronic device activation circuit 1155 to activate the electronic device 1105. In some embodiments, the earbud engagement detector 1130 sends a signal to the controller 1140 that the one or more magnets 1185 and the earbud 1175 have been coupled with the earphones holder body 1101. In these embodiments, upon receiving the signal from the earbud engagement detector 1130, the controller 1140 sends a signal to the electronic device activation circuit 1155 to deactivate the electronic device 1105.

In further embodiments, the electronic device controller 1140 sends a signal to electronic device activation circuit 1155 to operate the electronic device 1105 in another manner. For example, in some embodiments, upon receiving the signal from the earbud engagement detector 1130, the controller 1140 sends a signal to the electronic device activation circuit 1155 to adjust the volume of the signal from the electronic device 1105. Additionally, in some embodiments, the controller 1140 is able to send a signal to the electronic device activation circuit 1155 in order to pause the signal of an application or a program being transmitted by the electronic device 1105. Particularly, the controller 1140 is able to send any appropriate signal to the electronic device activation circuit 1155 in order to operate the electronic device 1105.

The magnetic earphones and cord holding system 1100 is able to send a signal to activate and/ or deactivate an electronic device 1105 such as a cell phone. For example, if the user's phone rings, the user is able to remove the set of earphones 1150 from the earphones holder body 1101 and a signal is sent to answer the phone and connect the call. Likewise, if the user is on a call and the set of earphones 1150 are coupled with the earphones holder body 1101, a signal is sent to hang up the phone and terminate the call. Similarly, the magnetic earphones and cord holding system 1100 is able to send a signal to start, resume, or stop an electronic device such as an electronic media player or gaming device. For example, if a user needs to interrupt playing a video game, playing music, playing a movie, or other media stream, the user is able to couple the set of earphones 1150 with the holder body 1101 in

order to pause the electronic device 1105. Then, when the user desires to resume using the electronic device 1105, the user is able to decouple the earphones 1150 from the holder body and send a signal and unpause the electronic device 1105. In this manner, the user is able to use the magnetic earphones and cord holding system 1100 to operate, activate and/or deactivate any programs or applications that are running on the electronic device 1105.

In some embodiments, the signal sent by the electronic device controller 1140 to the electronic device activation circuit 1155 and the signal sent by the electronic device activation circuit 1155 to the electronic device 1105 comprise one or more of infrared, infrared laser, radio frequency, wireless, WiFi, and Bluetooth®. However, the signal sent by the electronic device controller 1140 and the electronic device activation circuit 1155 are able to comprise any wireless signal as known in the art. Alternatively, in some embodiments, the signal sent by the electronic device controller 1140 and the electronic device activation circuit 1155 comprise a wired signal.

Figures 12A and 12B illustrate a side view of a magnetic earphones and cord holding system formed in two parts. The magnetic earphones and cord holding system 1200 comprises a first body 1201 and a second body 1202. The first body 1201 is substantially similar to the earphones holder body 1101 as discussed in relation to Figure 11 and comprises a groove (not shown) for receiving and releasably securing a headset cord, one or more magnetically attractable surfaces 1110, an earbud engagement detector (not shown), and an electronic device controller (not shown). As shown in Figures 12A and 12B, the first body 1201 comprises a coupling mechanism 1203 and the second body 1202 comprises a coupling mechanism 1205. The coupling mechanisms 1203 and 1205 enable the first body 1210 and the second body 1202 to couple together. In some embodiments, the coupling mechanisms 1203 and 1205 comprises a snap, a button, or a hook and loop fastening system. However, the coupling mechanisms 1203 and 1205 are able to comprise any appropriate coupling mechanisms as known in the art. In some embodiments, the second body 1202 comprises a button, a snap, a zipper, or an adornment.

Figure 13 illustrates a schematic view showing the components of a magnetic earphones and cord holding system in accordance with some embodiments. As shown in Figure 13, the magnetic earphones and cord holding system 1300 comprises an earbud engagement detector 1330, an electronic device controller 1340, and an electronic device activation circuit 1355. As described above, the earbud engagement detector 1330 detects an engagement of the earbud 1175 (Figure 11) with the one or more magnets 1110. The earbud engagement detector 1330 sends a signal to the electronic device controller 1340 based upon

the engagement status of the earbud. The electronic device controller 1340 processes the signal it receives from the earbud engagement detector 1330 and sends a signal to the electronic device activation circuit 1355 which operates an electronic device in a manner dependent upon the signal from the electronic device controller 1340. In some embodiments, the electronic device controller 1340 sends a signal to the electronic device activation circuit 1355 to activate the electronic device. In some embodiments, the electronic device controller 1340 sends a signal to the electronic device activation circuit 1355 to deactivate the electronic device.

Figure 14 illustrates a method of operating a set of earphones in accordance with some embodiments.

As shown in Figure 14, at the step 1404 an engagement status of an earbud is detected. In some embodiments, it is detected whether or not the earbud is coupled with an earphones holder body. Then, based upon the engagement status of the earbud, at the step 1406, a signal is sent to operate the electronic device. In some embodiments, the signal is one or more of an infrared, infrared laser, radio frequency, wireless, WiFi, and Bluetooth® signal. In some embodiments, the signal is a wired signal. In some embodiments, the signal is a signal to turn off or to turn on the electronic device.

Figure 15 illustrates a magnetic earphones holding system in accordance with further embodiments. The magnetic earphones holding system 1500 comprises an earphones holder body 1501 and a set of earphones 1550. The set of earphones 1550 transmits a signal from an electronic device 1505 such as an iPod, iPhone, any other similar cellular phone or smart phone, MP3 or music player, movie player, or other electronic device 1505. As will be apparent to someone of ordinary skill in the art, the set of earphones 1550 is able to transmit a signal from any appropriate electronic device 1505 as known in the art. For example, in some embodiments, the set of earphones 1550 transmits a signal from an electronic media player such as an iPad, smart phone, tablet PC, Mp4 player, or DivX Media format player.

The earphones holder body 1501 is in the shape of a zipper puller and comprises one or more magnetically attractable surfaces 1510 for removably coupling with one or more magnets 15815 of the set of earphones 1550, and an electronic device controller 1540. In some embodiments, the one or more magnetically attractable surfaces 1510 are magnets. In some of these embodiments, the magnets are neodymium magnets. In some embodiments, the holder body 1501 comprises a plurality of magnetically attractable surfaces 1510. In some embodiments, the earphones holder body 1501 comprises a body comprising a snap fastener, an adornment, a buckle attachment, or an item of jewelry and a magnet built into or

embedded within the body. In some embodiments, the earphones holder body 1501 further comprises a groove as described in relation to Fig. 1. In some embodiments, the set of earphones 1550 is a component of a hands free telephone adapter.

Using the one or more magnet 1585 of the earphones 1550, a user is able to couple the earphones 1550 with the one or more magnetically attractable surfaces 1510 of the earphones holder body 1501 when not in use. The one or more magnetically attractable surfaces 1510 are able to be fixedly or removably connected to the earphones holder body 1501. In some embodiments, the holder body 1501 further comprises one or more recesses for interlocking with the earbud 1575. In these embodiments, the body of the earbud 1575 is press fit or snap fit into the one or more recesses of the earphones holder body 1501.

As further shown in Figure 15, the earphones holder body 1501 comprises an electronic device controller 1540 and an earbud engagement detector 1530. The electronic device controller 1540 receives a signal from the earbud engagement detector 1530 and sends a signal to the electronic device activation circuit 1555 based upon the signal received from the earbud engagement detector 1530. The electronic device activation circuit 1555 operates an electronic device 1505 based upon the signal received from the controller 1540. In some embodiments, the earbud engagement detector 1530 sends a signal to the controller 1540 that the one or more magnets 1585 and the earbud 1575 have been decoupled from the earphones holder body 1501. In these embodiments, upon receiving the signal from the earbud engagement detector 1530, the controller 1540 sends a signal to the electronic device activation circuit 1555 to activate the electronic device 1505. In some embodiments, the earbud engagement detector 1530 sends a signal to the controller 1540 that the one or more magnets 1585 and the earbud 1575 have been coupled with the earphones holder body 1501. In these embodiments, upon receiving the signal from the earbud engagement detector 1530, the controller 1540 sends a signal to the electronic device activation circuit 1555 to deactivate the electronic device 1505.

As shown within Figure 15, the earbud engagement detector 1530 and the electronic device controller 1540 are components of the earphones holder body 1501. However, as will be apparent to someone of ordinary skill in the art, one or more of the earbud engagement detector 1530 and the electronic device controller 1540 are able to be components of the set of earphones 1550.

As shown within Figure 16, in some embodiments, the one or more magnets 1685 comprise a magnetically attractable surface that is a circular body that fits around the earphones 1650. In some embodiments, the one or more magnets 1685 removably couple

with the earphones 1650. In some of these embodiments, the magnetically attractable surface 1685 is stretchable and stretches to fit over the earphones 1650. In some embodiments, the magnetically attractable surface 1685 comprises a hinge or coupler which enables the magnetically attractable surface 1685 to be opened and coupled around the earphones 1650. In some embodiments, the magnetically attractable surface 1685 is able to be opened at coupler and then placed around the earphones 1650 and snap fit back into place. In some embodiments, the magnetically attractable surface 1685 comprises two pieces which are separated in order to removably couple the magnetically attractable surface 1685 with the earphones 1650. Particularly, the magnetically attractable surface 1685 is able to removably couple with the earphones 1650 by any appropriate mechanism as known in the art. Additionally, although the magnetically attractable surface 1685 is shown with a circular body, the magnetically attractable surface is able to comprise any appropriate shape for coupling with the earphones 1650. As further shown in Figure 16, the earbud engagement detector 1630 and the electronic device controller 1640 are components of the earphones 1650.

In further embodiments, the earbud engagement detector 1730 (Figure 17) is a component of an earbud 1775 and sends a signal to a electronic device controller 1740 incorporated into a separate body 1701.

Figure 17 illustrates a magnetic earphones holding system in accordance with further embodiments. The magnetic earphones holding system 1700 comprises an earphones holder body 1701 and a set of earphones 1750. The set of earphones 1750 transmits a signal from an electronic device 1705 such as an iPod, iPhone, any other similar cellular phone or smart phone, MP3 or music player, movie player, or other electronic device 1705. As will be apparent to someone of ordinary skill in the art, the set of earphones 1750 is able to transmit a signal from any appropriate electronic device 1705 as known in the art. For example, in some embodiments, the set of earphones 1750 transmits a signal from an electronic media player such as an iPad, smart phone, tablet PC, Mp4 player, or DivX Media format player.

As described above, the earphones holder body 1701 is able to be in a shape of a zipper puller, a snap fastener, an adornment, a buckle attachment, or an item of jewelry and a magnet built into or embedded within the body and comprises one or magnetically attractable surfaces 1710 and an electronic device controller 1740. As shown in Figure 17, the earphones 1750 comprise one or more magnets 1785 and an earbud engagement detector 1730. In some embodiments, the electronic device controller 1740 and the earbud engagement detector 1730 are components of the earphone holder body 1701. Alternatively,

in some embodiments, the electronic device controller 1740 and the earbud engagement detector 1730 are components of the set of earphones 1750.

Using the one or more magnet 1785 of the earphones 1750, a user is able to couple the earphones 1750 with the one or more magnetically attractable surfaces 1710 of the earphones holder body 1701 when not in use. The one or more magnetically attractable surfaces 1710 are able to be fixedly or removably connected to the earphones holder body 1701. In some embodiments, the holder body 1701 further comprises one or more recesses for interlocking with the earbud 1775. In these embodiments, the body of the earbud 1775 is press fit or snap fit into the one or more recesses of the earphones holder body 1701.

The electronic device controller 1740 receives a signal from the earbud engagement detector 1730 and sends a signal to the electronic device activation circuit 1755 based upon the signal received from the earbud engagement detector 1730. The electronic device activation circuit 1755 operates an electronic device 1705 based upon the signal received from the controller 1740. Particularly, the controller 1740 relays the signal from the earbud engagement detector 1730 to the electronic device 1705. As described above, in some embodiments the signal received from the controller 1740 is a signal to activate and/or deactivate the electronic device 1705.

In further embodiments, the earphones holder body 1701 comprises an item that is placed on a counter top or other similar item. In some embodiments, the electronic device controller 1740, is able to send a signal to an activation circuit 1755 of an electronic device 1705 that is removably coupled with an external docking station.

In some embodiments, the signal sent by the electronic device controller 1740 to the electronic device activation circuit 1755 and the signal sent by the electronic device activation circuit 1755 to the electronic device 1705 comprise one or more of infrared, infrared laser, radio frequency, wireless, WiFi, and Bluetooth®. However, the signal sent by the electronic device controller 1740 and the electronic device activation circuit 1755 are able to comprise any wireless signal as known in the art. Alternatively, in some embodiments, the signal sent by the electronic device controller 1740 and the electronic device activation circuit 1755 comprise a wired signal.

In further embodiments, the set of earphones 1750 comprise wireless earphones. In these embodiments, the earbud engagement detector 1730 sends a wireless signal to the electronic device controller 1740 based on the engagement status of the earphones and the earphones 1750 receive a wireless content signal from the electronic device 1705.

Figure 18 illustrates a magnetic earphones holding system in accordance with some embodiments. The system 1800 comprises a set of earphones comprising one or more magnets or magnetically attractable surfaces 1885 built into the earbud 1875 and one or more magnets or magnetically attractable surfaces 1895 built into the earbud 1875'. As shown in Figure 18, the earbud 1875 comprises an earbud engagement detector 1830 and an electronic device controller 1840 built into the body of the earbud 1875. Although, the earbud engagement detector 1830 and an electronic device controller 1840 built into a signal body of the earbud 1875, as will be apparent to someone of ordinary skill in the art, the earbud engagement detector 1830 and the electronic device controller 1840 are able to be components of different earbuds.

The electronic device controller 1840 receives a signal from the earbud engagement detector 1830 based upon an engagement of the earbud 1875 with the earbud 1875'. In some embodiments, the earbud engagement detector 1830 sends a signal to the controller 1840 that the one or more magnets or magnetically attractable surfaces 1885 have been removed from the one or more magnets or magnetically attractable surfaces 1895. In these embodiments, upon receiving the signal from the earbud engagement detector 1830, the controller 1840 sends a signal to the electronic device activation circuit 1855 to activate the electronic device 1805. In some embodiments, the earbud engagement detector 1830 sends a signal to the controller 540 that the earbud 1875 has been coupled with the earbud 1875'. In these embodiments, upon receiving the signal from the earbud engagement detector 1830, the controller 1840 sends a signal to the electronic device activation circuit 1855 to deactivate the electronic device 1805.

In operation, the earphones holder enables a user to comfortably utilize a headset without becoming entangled within the cord. In some embodiments, a user uses a groove and the magnets of a cord holder body while using the headset to listen to an electronic device. A user places a set of earphones near to the magnet in order to allow the earphones to magnetically attract to and be held by the magnet. When the user wishes to use the electronic device, the earphones are removed from the magnet and a signal is transmitted in order to active an electronic device such as a music player or cell phone. Then, when the user no longer wishes to use the electronic device, the earphones are recoupled with the magnet and the electronic device is deactivated. In this manner, the earphones are able to be removed from the earphones holder body and an electronic device is automatically activated in order to answer a telephone call. Then, when the telephone call is terminated, the user is able to recouple the earphones with the earphones holder body and automatically deactivate the

device. Alternatively, the earphones are able to be removed from the earphones holder body and an electronic device is automatically activated in order to listen to music transmitted from a music player or cell phone and then recoupled with the earphones holder body in order to deactivate the device when the use of the earphones is no longer desired.

Referring now to Figures 19A– 19E, an embodiment of a magnetic earphones and cord holding system is depicted therein. The magnetic earphones and cord holding system 1900 comprises a body 1901 comprising a touch sensor 1903, an on/off button 1911, a microphone 1913, a speaker 1915, and a charging port 1917. As shown in Figures 19A– 19E, the body 1901 also comprises an electronic device controller 1940 and a touch sensor detector 1960. In some embodiments, the system comprises an earphones jack 1907 and one or more magnets or magnetically attractable surfaces 1920 and 1920' and one or more earbud engagement detectors 1930 and 1930'. The one or more magnets or magnetically attractable surfaces 1920 and 1920' are configured to removably couple with one or more magnets 1985 and 1985' of a set of earphones 1950. In further embodiments, the body 1901 comprises a groove and/or one or more recesses for securing the earphones 1950 and the cord 1965, as described above.

In some embodiments, the electronic device controller 1940 receives a signal from the earbud engagement detector 1930 and sends a signal to the electronic device activation circuit 1955 based upon the signal received from the earbud engagement detector 1930. The electronic device activation circuit 1955 operates an electronic device 1905 based upon the signal received from the controller 1940. In some embodiments, the earbud engagement detector 1930 sends a signal to the controller 1940 that the one or more magnets 1985 and the earbud 1975 have been decoupled from the earphones holder body 1901. In these embodiments, upon receiving the signal from the earbud engagement detector 1930, the controller 1940 sends a signal to the electronic device activation circuit 1955 to activate the electronic device 1905. In some embodiments, the earbud engagement detector 1930 sends a signal to the controller 1940 that the one or more magnets 1985 and the earbud 1975 have been coupled with the earphones holder body 1901. In these embodiments, upon receiving the signal from the earbud engagement detector 1930, the controller 1940 sends a signal to the electronic device activation circuit 1955 to deactivate the electronic device 1905.

In further embodiments, the touch sensor detector 1960 receives a signal from the touch sensor 1903 based upon a contact with the touch sensor 1903 and sends a signal to the electronic device controller 1940, which sends a signal to the electronic device activation circuit 1955. The electronic device activation circuit 1955 operates an electronic device

1905 based upon the signal received from the controller 1940. For example, in some embodiments, the touch sensor detector 1960 sends a signal to the electronic device controller 1940 that the touch sensor 1903 has been tapped, double-tapped, and/or swiped. In response, the electronic device controller 1940 sends a signal to the electronic device activation circuit 1955 to operate the electronic device 1905. In some embodiments, the electronic device controller 1940 is able to send a signal to activate/de-activate the electronic device, turn up or turn down the volume, change the playing media, and/or change the program being operated by the electronic device 1905. Particularly, the electronic device controller 1940 is able to send any appropriate desired control signal to the electronic device 1905. Additionally, the touch sensor 1903 is able to be operated in any desired manner.

In some embodiments, the magnetic and cord holding system 1900 is used with the set of earphones 1950. In these embodiments, the power input 1995 is inserted into the earphones jack 1907 and the one or more magnets 1985 and 1985' are removably coupled with the one or more magnets or magnetically attractable surfaces 1920 and 1920'. In some embodiments, a user is able to remove the earphones 1950 and transmit a signal in order to activate the electronic device 1905, as described above. Then, with the earphones in their ears, a user is able to utilize the touch sensor 1903 in order to operate the electronic device 1905. In some embodiments, the magnetic and cord holding system 1900 is used with a short cord set of earphones. Consequently, the set of earphones is able to be used without becoming entangled in the clothing of the user. Particularly, as shown in Fig. 20, because the power input 1975 and the earphones 1950 are held closely together when coupled with the body 1901, the cord 1965 of the earphones only needs to long enough to comfortably couple the earphones 1950 with the ears of a user and enable the user to use the touch sensor 1903 and/or the microphone 1913 of the body 1901 of the magnetic and cord holding system 1900.

In further embodiments, the magnetic and cord holding system 1900 is able to be used without the set of earphones 1950. For example, the touch sensor 1903 is able to be contacted in order activate the electronic device 1905 and then a user is able to utilize the touch sensor 1903 in order to operate the electronic device 1905. In these embodiments, the touch sensor 1903 is able to be utilized in order to answer a telephone call and communicate using the microphone 1913 and the speaker 1915. Then, when the telephone call is terminated, the user is able to utilize the touch sensor 1903 to terminate the call and deactivate the electronic device 1905. Additionally, in some embodiments, the system 1900 and the touch sensor 1903 are used without audio in order to control a program running on the electronic device 1905.

The magnetic and cord holding system 1900 is able to be used with a variety of electronic devices and in a variety of settings. For example, in some embodiments, the system 1900 is utilized with an electronic device that is coupled with an external docking station. In further embodiments, the system 1900 is able to be used as a controller for a game or program located on the electronic device. In these embodiment the touch sensor 1903 is able to be utilized to send control messages to the electronic device in order to control the game or program. In further embodiments, the system 1900 is able to receive a signal from an electronic device. For example, in some embodiments the system 1900 is able to receive an audio signal from the electronic device through the speaker 1915. Further, in some embodiments, the speaker 1915 and the microphone 1913 are used to communicate voice controls to the electronic device 1905.

In some embodiments, the signal sent by the electronic device controller 1940 to the electronic device activation circuit 1955 and the signal sent by the electronic device activation circuit 1955 to the electronic device 1905 comprise one or more of infrared, infrared laser, radio frequency, wireless, WiFi, and Bluetooth®. However, the signal sent by the electronic device controller 1940 and the electronic device activation circuit 1955 are able to comprise any wireless signal as known in the art. Alternatively, in some embodiments, the signal sent by the electronic device controller 1940 and the electronic device activation circuit 1955 comprise a wired signal.

Figure 21 illustrates a block diagram showing the components of the body 1901 of the system 1900. As described above, the body 1901 comprises a touch sensor 1903, an on/off button 1905, a microphone 1913, a speaker 1915, and a charging port 1917. As shown in Figures 19A–19E, the body 1901 also comprises an electronic device controller 1940 and a touch sensor detector 1960. In some embodiments, the system comprises an earphones jack 1907 and one or magnets or magnetically attractable surfaces 1920 and 1920' and one or more earbud engagement detectors 1930 and 1930'. In some embodiments, the body 1901 comprises a printed circuit board 1923 and a battery 1925 for supplying power to the system 1900. In some embodiments, the body 1901 further comprises an LED light 1919 for indicating that the body 1901 is powered on. In some embodiments, the earphones jack 1907 is a 3.5mm jack. However, as will apparent to someone of ordinary skill in the art, the earphones jack 1907 is able to comprises any appropriately sized jack. In some embodiments, the charging port 1917 is a USB port. However, the charging port 1917 is able to comprise any appropriately sized charging port.

Figure 22 illustrates the magnetic and cord holding system 1900 removably coupled to a shirt collar in accordance with some embodiments. The body 1901 of the system 1900 has been coupled to the shirt 2200 by using the clip 1909, as shown in Figures 19A and 19B. When using the clip 1909, a user is able to secure the body 1901 in a convenient, desired location. As will be apparent to someone of ordinary skill in the art, the body 1901 is able to be secured in any appropriate manner as known in the art. For example, in some embodiments, the body 1901 is coupled with a lanyard which is placed around a neck of a user in order to place the body 1901 in a convenient location.

Figure 23 illustrates a schematic view showing the components of a magnetic earphones and cord holding system in accordance with some embodiments. As shown in Figure 23, the magnetic earphones and cord holding system 2300 comprises an earbud engagement detector 2330, an electronic device controller 2340, and an electronic device activation circuit 355. As described above, the earbud engagement detector 2330 detects an engagement of an earbud with the one or more magnets of the body as shown in Figures 19A-19E. The earbud engagement detector 2330 sends a signal to the electronic device controller 340 based upon the engagement status of the earbud. The electronic device controller 2340 processes the signal it receives from the earbud engagement detector 2330 and sends a signal to the electronic device activation circuit 2355 which operates an electronic device in a manner dependent upon the signal from the electronic device controller 2340. In some embodiments, the electronic device controller 2340 sends a signal to the electronic device activation circuit 2355 to activate the electronic device. In some embodiments, the electronic device controller 2340 sends a signal to the electronic device activation circuit 2355 to deactivate the electronic device.

As further shown in Figure 23, the magnetic earphones and cord holding system 2300 comprises a touch sensor detector 2360. The touch sensor detector detects a contact of the touch sensor 903 (Figure 9A) and sends a signal to the electronic device controller 2340 based upon the contact with the touch sensor 903. The electronic device controller 2340 processes the signal it receives from the touch sensor detector 2360 and sends a signal to the electronic device activation circuit 2355 to operate an electronic device in a manner based upon the signal received from the electronic device controller 2340. In some embodiments, the electronic device controller 2340 sends a signal to the electronic device activation circuit 2355 to activate/de-activate the electronic device, turn up or turn down the volume, change the playing media, and/or change the program being operated by the electronic device.

Figure 24 illustrates a method of operating a magnetic earphones and cord holding system comprising a touch sensor in accordance with some embodiments. In the step 2404, a contact of a touch sensor is detected. For example, in some embodiments it is detected that the touch sensor is tapped, double-tapped, swiped in a sideways direction, and/or swiped in an up and down direction. Then, based upon the contact with the touch sensor, in the step 2406, a signal is sent to operate the electronic device. In some embodiments, the signal is one or more of an infrared, infrared laser, radio frequency, wireless, WiFi, and Bluetooth® signal. In some embodiments, the signal is a wired signal. In some embodiments, the signal is a signal to activate/de-activate the electronic device, turn up or turn down the volume, change the playing media, and/or change the program being operated by the electronic device.

The magnetic earphones and cord holding system enables a user to automatically activate and/ or deactivate an electronic device and place the earphones in a convenient location when using the earphones and when not in use. Consequently, the earphones and cord holding system has the advantage of providing an inexpensive and easy way to hold a headset cord in a comfortable and convenient position while utilizing an electronic device. Additionally, the earphones and cord holding system is able to conserve power by ensuring that the electronic device is only activated when needed. Accordingly, the magnetic earphones and cord holding system described herein has numerous advantages.

The presently claimed invention has been described in terms of specific embodiments incorporating details to facilitate the understanding of the principles of construction and operation of the invention. As such, references herein to specific embodiments and details thereof are not intended to limit the scope of the claims appended hereto. It will be apparent to those skilled in the art that modifications can be made to the embodiments chosen for illustration without departing from the spirit and scope of the invention.

CLAIMS

What is claimed is:

1. A system for holding a set of earphones comprising:
 - a. a holder body comprising one or more magnets; and
 - b. a set of earphones comprising a magnetically attractable surface for removably coupling with the one or more magnets.
2. The system of Claim 1 wherein the holder body is a closure mechanism that releasably couples a first portion of an article to a second portion of the article.
3. The system of Claim 1 wherein the holder body is one or more of snaps, a button, a releasable clip, zipper, and a hook and loop fastening system.
4. The system of Claim 1 wherein the holder body is an accessory item comprising one or more of a necklace, a broach, a pair of earrings, a bracelet and a sunglass lanyard.
5. The system of Claim 1 wherein the magnetically attractable surface is non-removable.
6. The system of Claim 1 wherein the magnetically attractable surface is removable.
7. The system of Claim 1 further comprising one or more additional magnets.
8. The system of Claim 1 further comprising one or more grooves for releasably holding a cord of the set of earphones.
9. The system of Claim 1 wherein the magnetically attractable surface is attached to the cord of the earphones.
10. An earphones holder comprising:
 - a. a holder body; and
 - b. one or more magnetically attractable surfaces.

11. The earphones holder of Claim 10 wherein the holder body comprises a zipper puller, a snap fastener, an adornment, a buckle attachment, or an item of jewelry.
12. The earphones holder of Claim 10 wherein the one or more magnetically attractable surfaces comprise one or more magnets.
13. The earphones holder of Claim 12 wherein the one or more magnetically attractable surfaces are configured for removably coupling with a metal part of an earbud.
14. The earphones holder of Claim 10 wherein the one or more magnetically surfaces are built into or embedded within the body.
15. The earphones holder of Claim 10 wherein the holder body comprises one or more grooves for releasably holding a cord of a set of earphones.
16. A method of securing a set of earphones comprising:
 - a. coupling a magnetically attractable surface to a set of earphones; and
 - b. coupling the magnetically attractable surface to a magnet coupled to an additional article in order to secure the earphones.
17. The method of Claim 16 wherein the additional article comprises a zipper puller, a snap fastener, an adornment, a buckle attachment, or an item of jewelry.
18. The method of Claim 16 wherein additional article is an accessory item comprising one or more of a necklace, a broach, a pair of earrings, a bracelet and a sunglass lanyard
19. The method of Claim 16 wherein the one or more magnetically attractable surfaces comprises one or more magnets.
20. The method of Claim 16 wherein the one or more magnetically surfaces are built into or embedded within the additional article.

21. The method of Claim 16 wherein the additional article comprises one or more grooves for releasably holding a cord of a set of earphones.
22. An earphones holder comprising:
 - a. a holder body;
 - b. one or more magnetically attractable surfaces attached to the holder body;
 - c. an earbud engagement detector; and
 - d. an electronic device controller for controlling an electronic device coupled to the earphones.
23. The earphones holder of Claim 22 wherein a magnet of the earphones removably couples with the one or more magnetically attractable surfaces.
24. The earphones holder of Claim 22 wherein the magnetically attractable surface comprises one or more magnets and removably couples with a metal portion of the earphones.
25. The earphones holder of Claim 22 wherein the electronic device controller is configured to activate the electronic device when the earphones are decoupled from the holder body.
26. The earphones holder of Claim 22 wherein the electronic device controller is configured to deactivate the electronic device when the earphones are coupled with the holder body.
27. The earphones holder of Claim 22 wherein the earphones holder body comprises a mechanism for attaching the earphones holder to an additional article.
28. The earphones holder of Claim 27 wherein the mechanism is a clip.
29. The earphones holder of Claim 22 wherein the earphones holder body comprises a zipper puller, a snap fastener, an adornment, a buckle attachment, or an item of jewelry.

30. The earphones holder of Claim 22 wherein the holder body comprises one or more recesses for removably coupling with a body of the earphones.
31. The earphones holder of Claim 22 further comprising a groove for releasably receiving a cord of the set of headphones.
32. A system for holding a set of earphones comprising:
 - a. an earphones holder body comprising:
 - i. a groove for holding a headset cord;
 - ii. one or more magnetically attractable surfaces;
 - iii. an electronic device controller;
 - iv. an earbud engagement detector; and
 - b. a set of earphones comprising one or more magnets coupled to the earphones.
33. The system of Claim 32 wherein the one or more magnetically attractable surfaces comprise one or more magnets.
34. The system of Claim 32 wherein the electronic device controller is configured to activate and/or deactivate an electronic device by sending a signal to an electronic device activation circuit.
35. The system of Claim 34 wherein the electronic device controller sends a signal to the electronic device activation circuit to activate the electronic device when the earphones are decoupled from the one or more magnetically attractable surfaces of the earphones holder body.
36. The system of Claim of Claim 34 wherein the electronic device controller sends a signal to the electronic device activation circuit to deactivate the electronic device when the earphones are coupled with the one or more magnetically attractable surfaces of the earphones holder body.
37. The system of Claim 32 wherein the holder body further comprises a mechanism for attaching to an additional article.

38. The system of Claim 37 wherein the mechanism is a clip.
39. The system of Claim 32 wherein the holder body comprises a zipper puller, a snap fastener, an adornment, a buckle attachment, or an item of jewelry.
40. The system of Claim 32 wherein the holder body comprises an accessory item comprising one or more of a necklace, a broach, a pair of earrings, a bracelet and a sunglass lanyard.
41. The system of claim 32 wherein the holder body further comprises one or more recesses for removably coupling with a body of the earphones.
42. A method of operating an electronic device comprising:
 - a. detecting an engagement status of an earbud;
 - b. sending a signal to an electronic device based upon the engagement status of the earbud; and
 - c. operating the electronic device based upon the engagement status of the earbud.
43. The method of Claim 42 wherein the electronic device is activated.
44. The method of Claim 42 wherein the electronic device is deactivated.
45. A system for holding a set of earphones comprising:
 - a. a holder body;
 - b. one or more magnetically attractable surfaces attached to the holder body for removably coupling with a set of earphones;
 - c. a touch sensor;
 - d. a touch sensor detector; and
 - e. an electronic device controller for controlling an electronic device.
46. The system of Claim 45 wherein the system wirelessly communicates with the electronic device.
47. The system of Claim 45 further comprising an earbud engagement detector.

48. The system of Claim 45 wherein the touch sensor detector receives a signal from the touch sensor and sends a signal to the electronic device controller.
49. The system of Claim 48 wherein the touch sensor detector sends a signal to the electronic device controller that the touch sensor has been tapped, double-tapped, or swiped.
50. The system of Claim 48 wherein the electronic device controller sends a signal to an electronic device to operate the electronic device based upon the signal from the touch sensor detector.
51. The system of Claim 50 wherein the touch sensor detector sends a signal to the electronic device to activate or deactivate the electronic device.
52. An earphones holder for communicating with an electronic device comprising:
 - a. an earphones holder body comprising:
 - i. a touch sensor; and
 - ii. one or more magnetically attractable surfaces for removably coupling with a set of earphones,wherein the touch sensor controls an electronic device coupled to the earphones holder.
53. The earphones holder of Claim 52 wherein the set of earphones is coupled to an earphones jack of the earphones holder.
54. The earphones holder of Claim 52 wherein the electronic device is wirelessly coupled to the earphones holder.
55. The earphones holder of Claim 52 further comprising an earbud engagement detector.
56. The earphones holder of Claim 52 wherein the touch sensor is tapped, double-tapped, or swiped in order to control the electronic device.

57. The earphones holder of Claim 52 further comprising an attachment mechanism for attaching to an additional article.
58. The earphones holder of Claim 57 wherein the attachment mechanism is a clip.
59. A method of operating an electronic device comprising:
 - a. touching a touch sensor located on an earphones holder body comprising one or more magnets for removably coupling with a set of earphones;
 - b. sending a signal to a touch sensor detector; and
 - c. sending a signal to an electronic device based upon the signal sent to the touch sensor detector.
60. The method of Claim 59 wherein the touch sensor is tapped, double-tapped, or swiped.
61. The method of Claim 59 wherein the touch sensor detector receives a signal from the touch sensor and sends a signal to an electronic device controller.
62. The method of claim 59 wherein the electronic device is operated by touching the touch sensor.

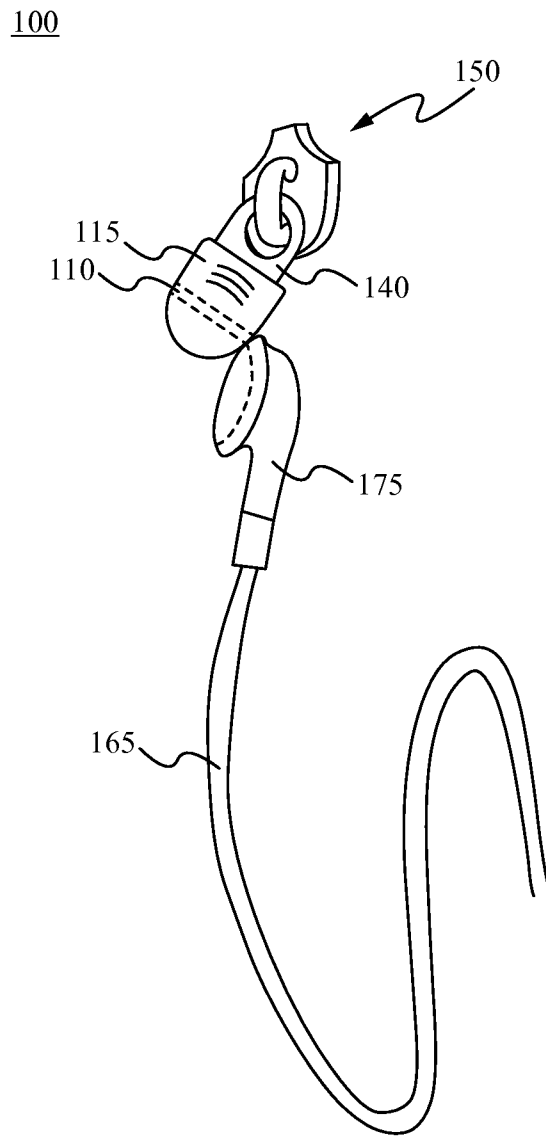

Fig. 1

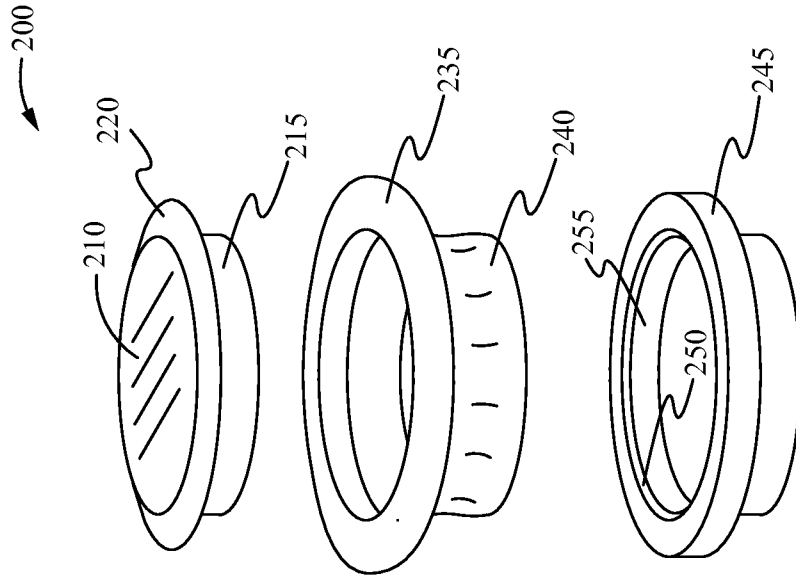

Fig. 2B

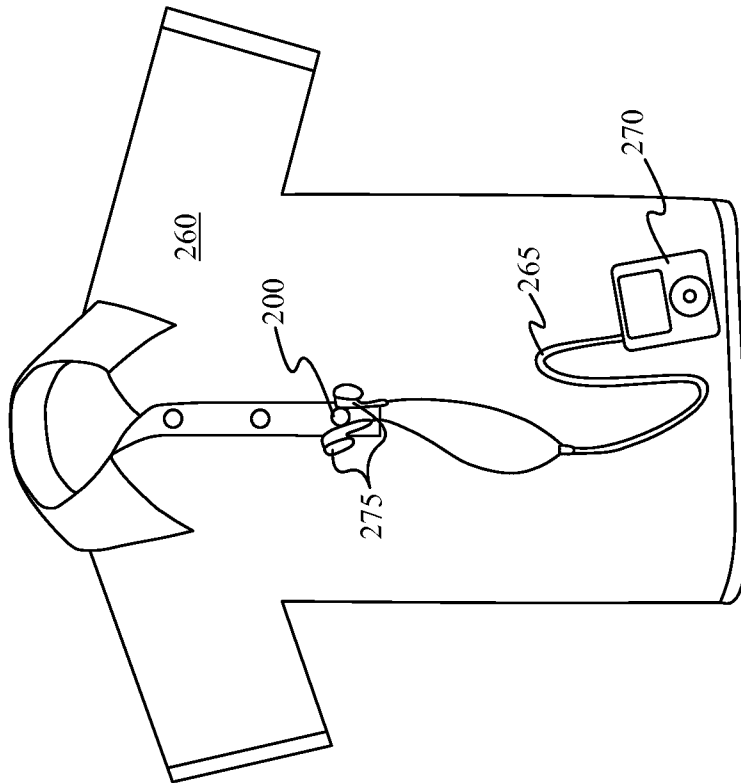

Fig. 2A

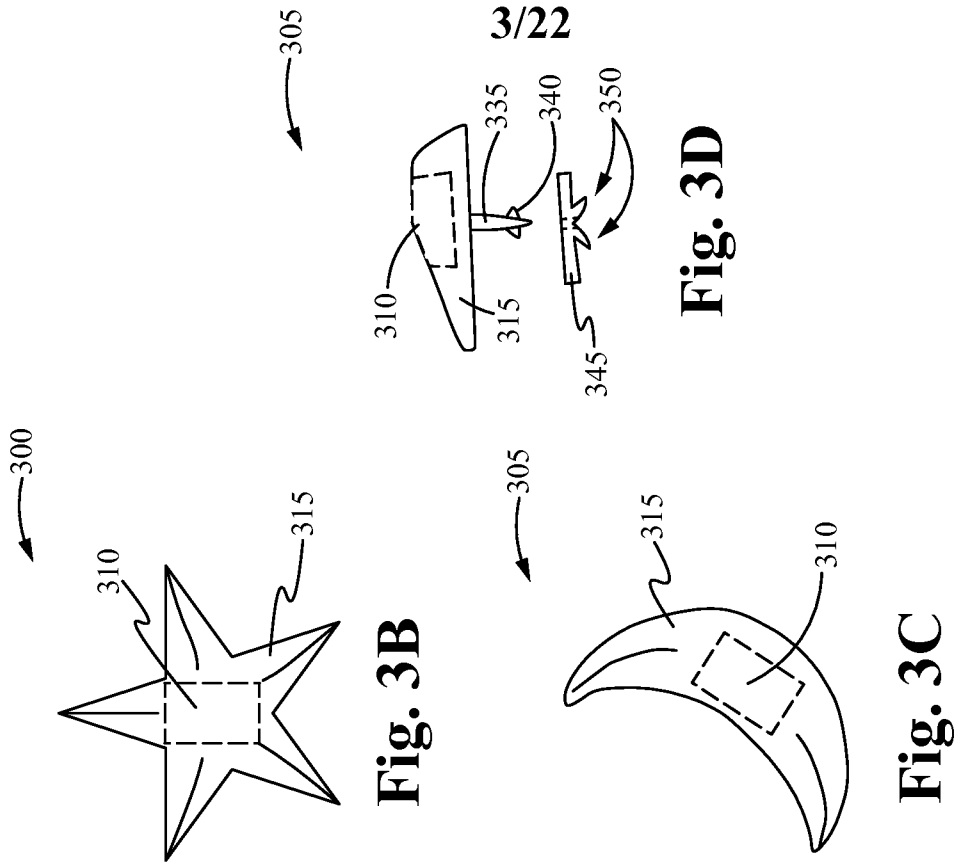

Fig. 3B

Fig. 3D

Fig. 3C

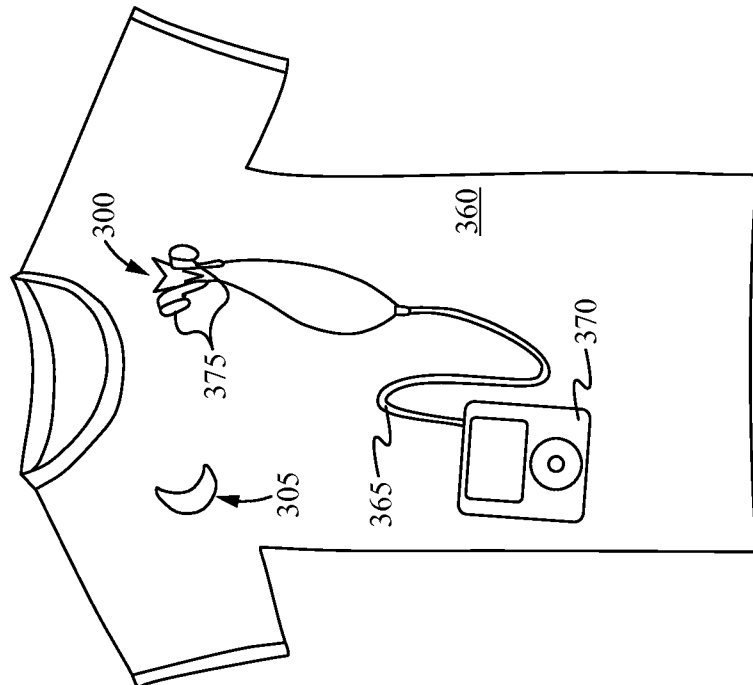

Fig. 3A

400

4/22

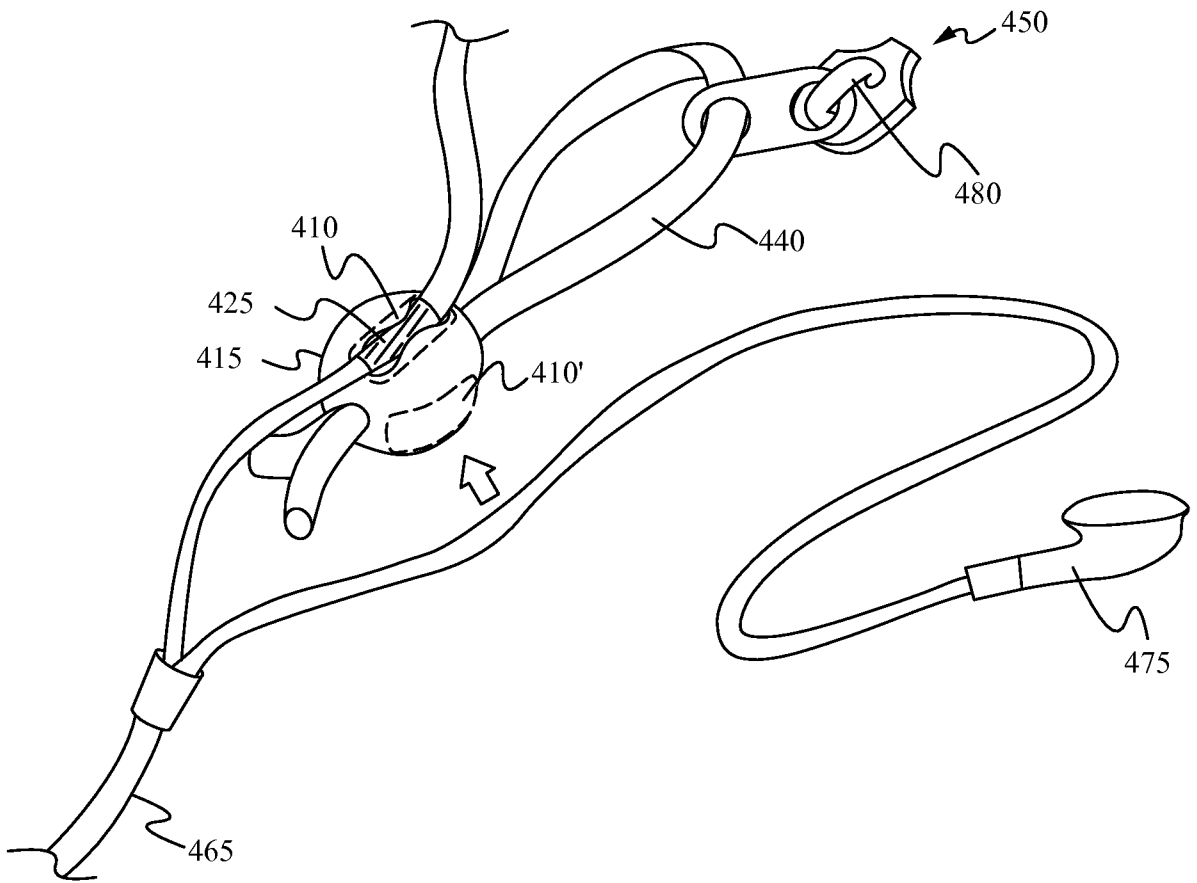

Fig. 4

5/22

500

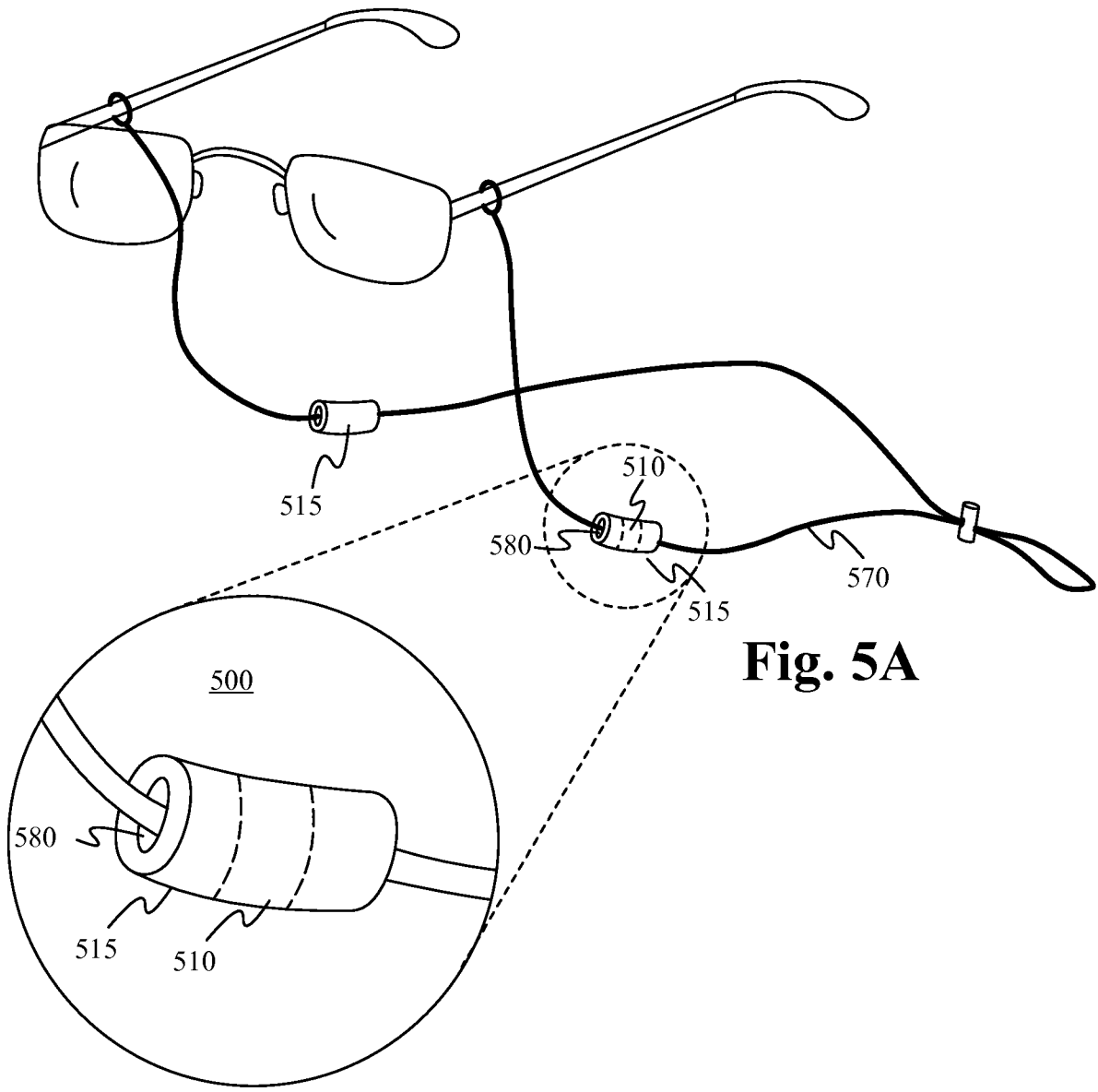

Fig. 5A

Fig. 5B

6/22

500

Fig. 5E

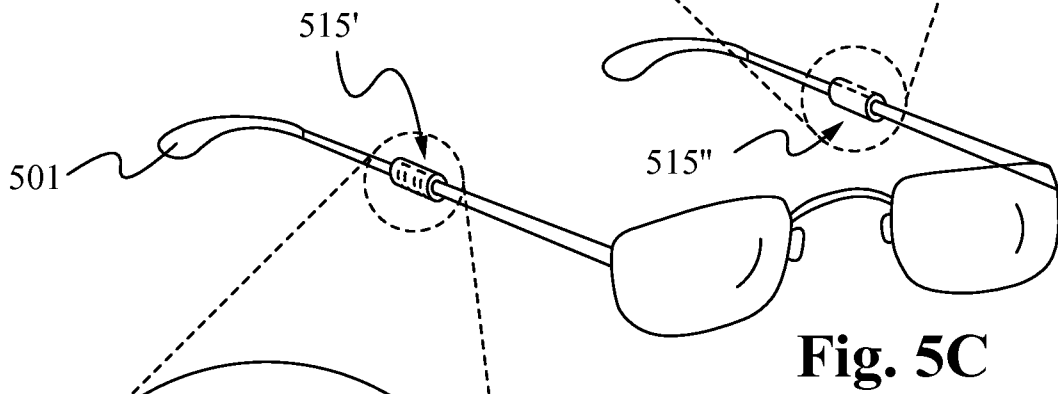
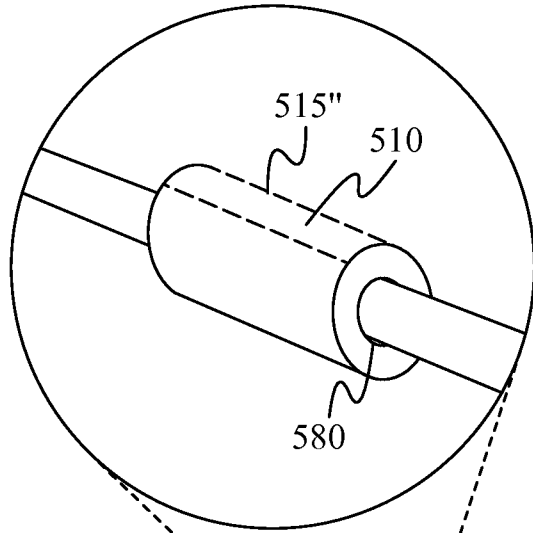

Fig. 5C

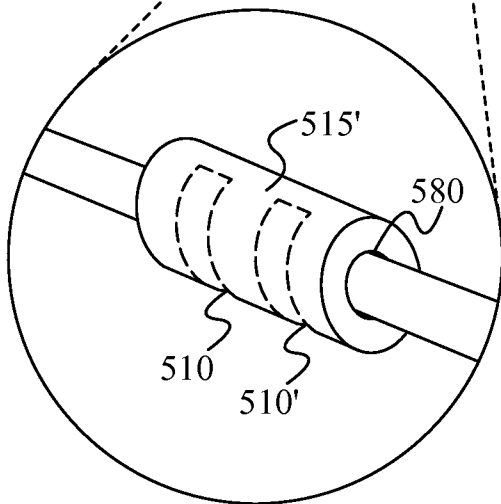

Fig. 5D

7/22

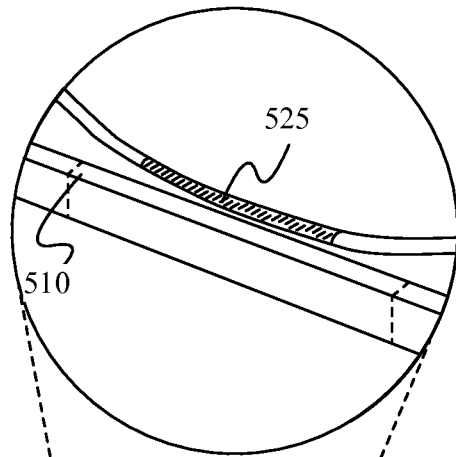

Fig. 5G

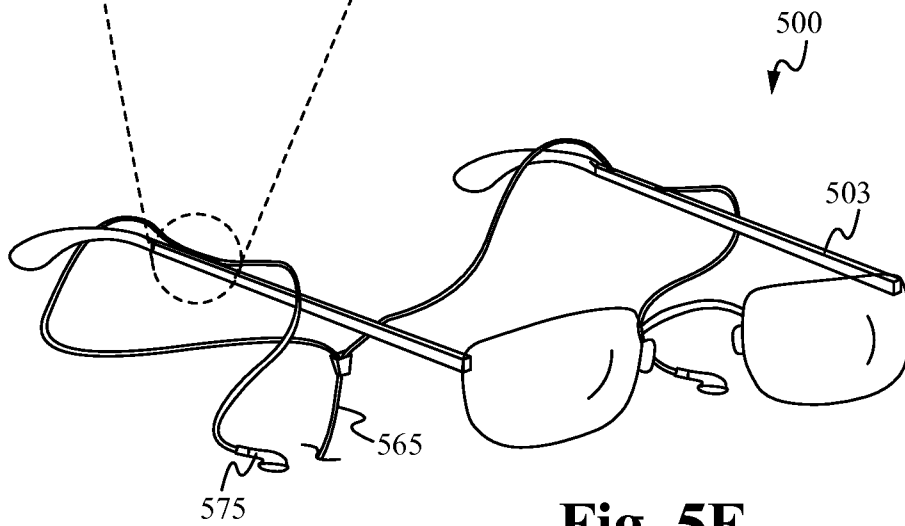

Fig. 5F

8/22

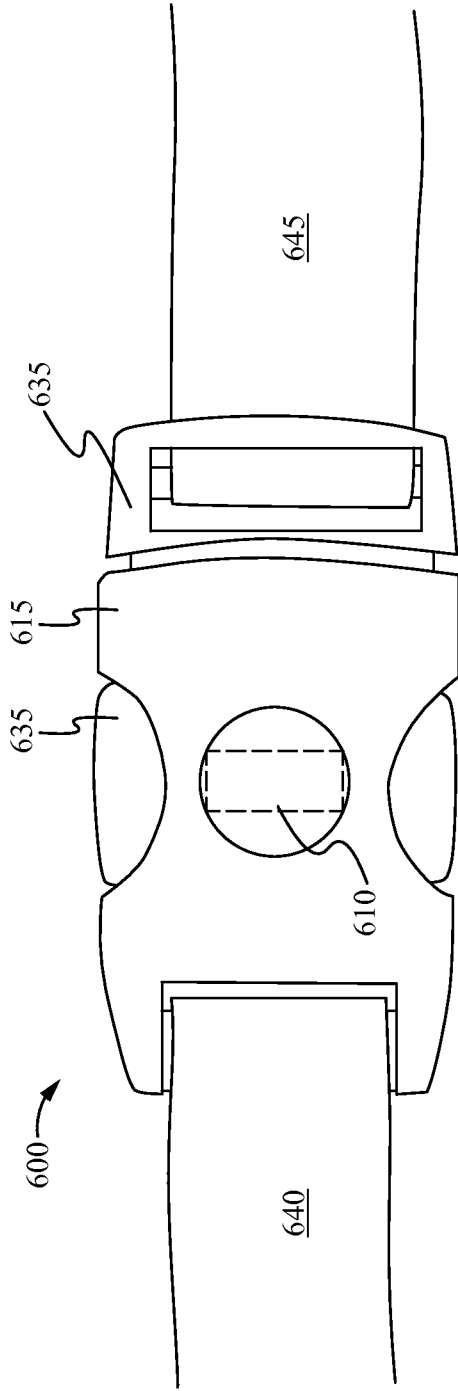

Fig. 6A

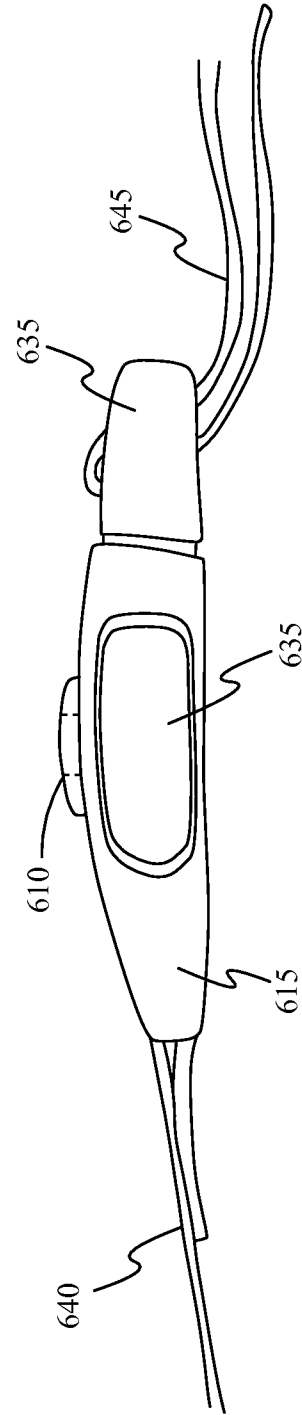

Fig. 6B

9/22

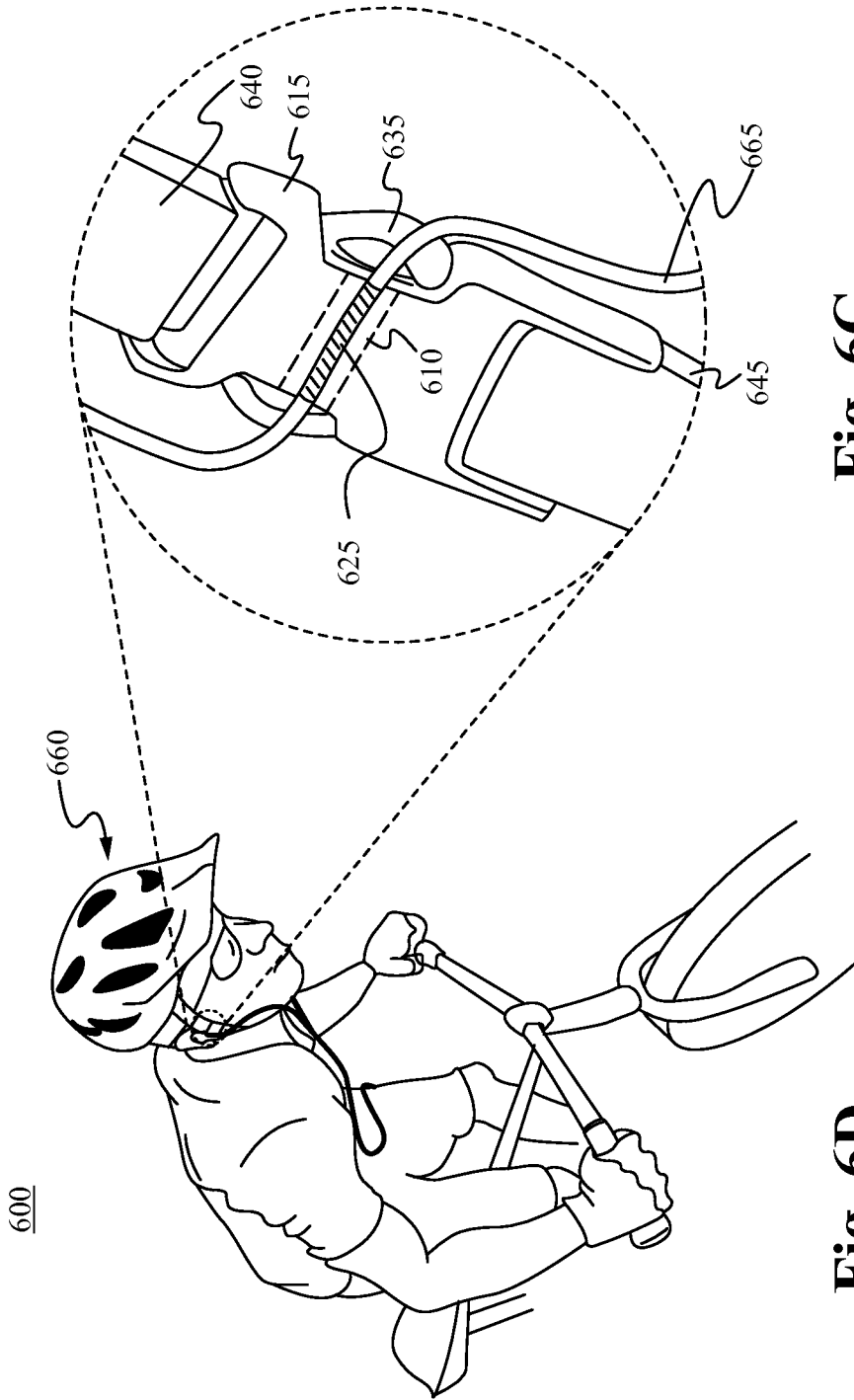

Fig. 6C

Fig. 6D

600

10/22

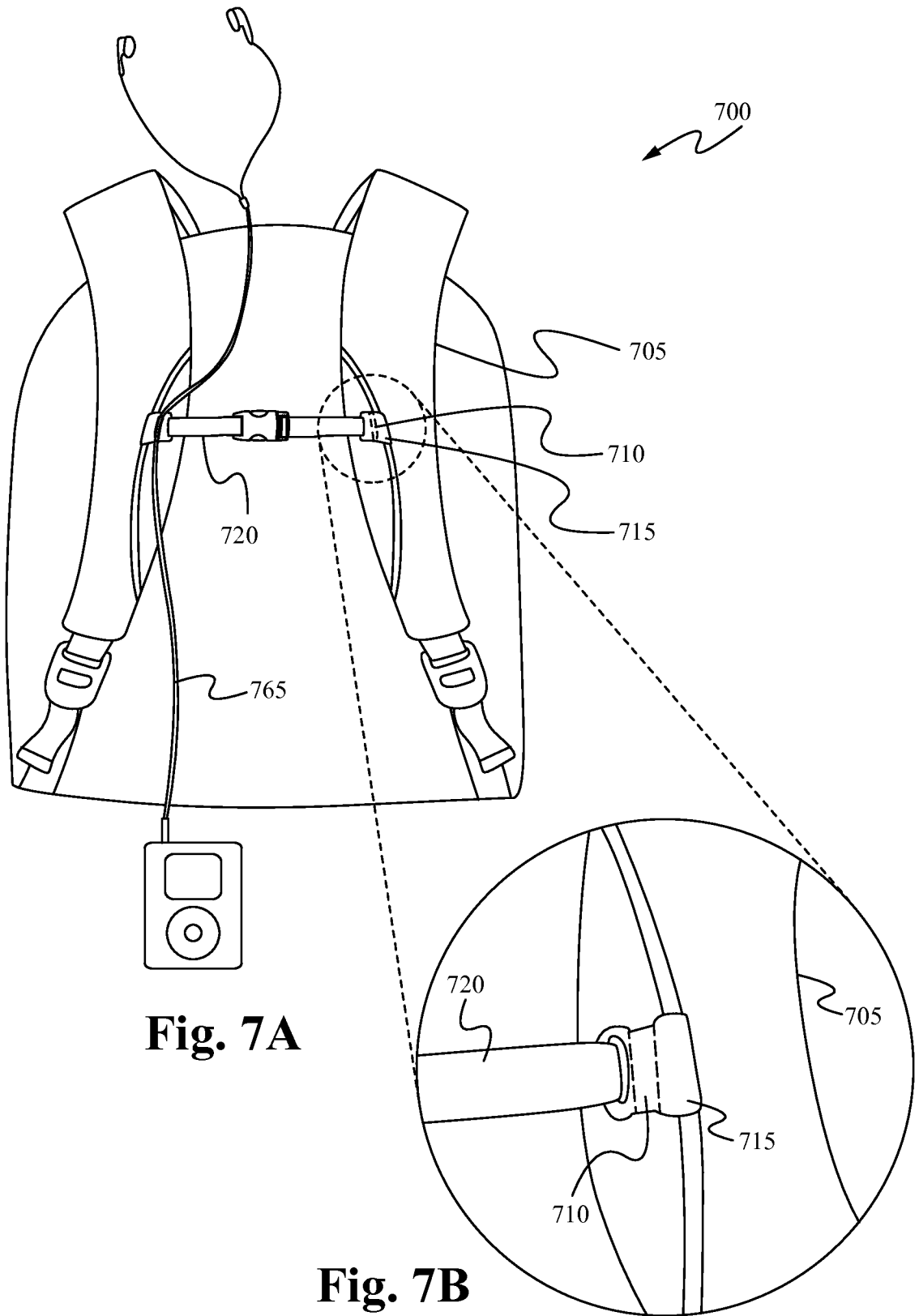

Fig. 7A

Fig. 7B

11/22

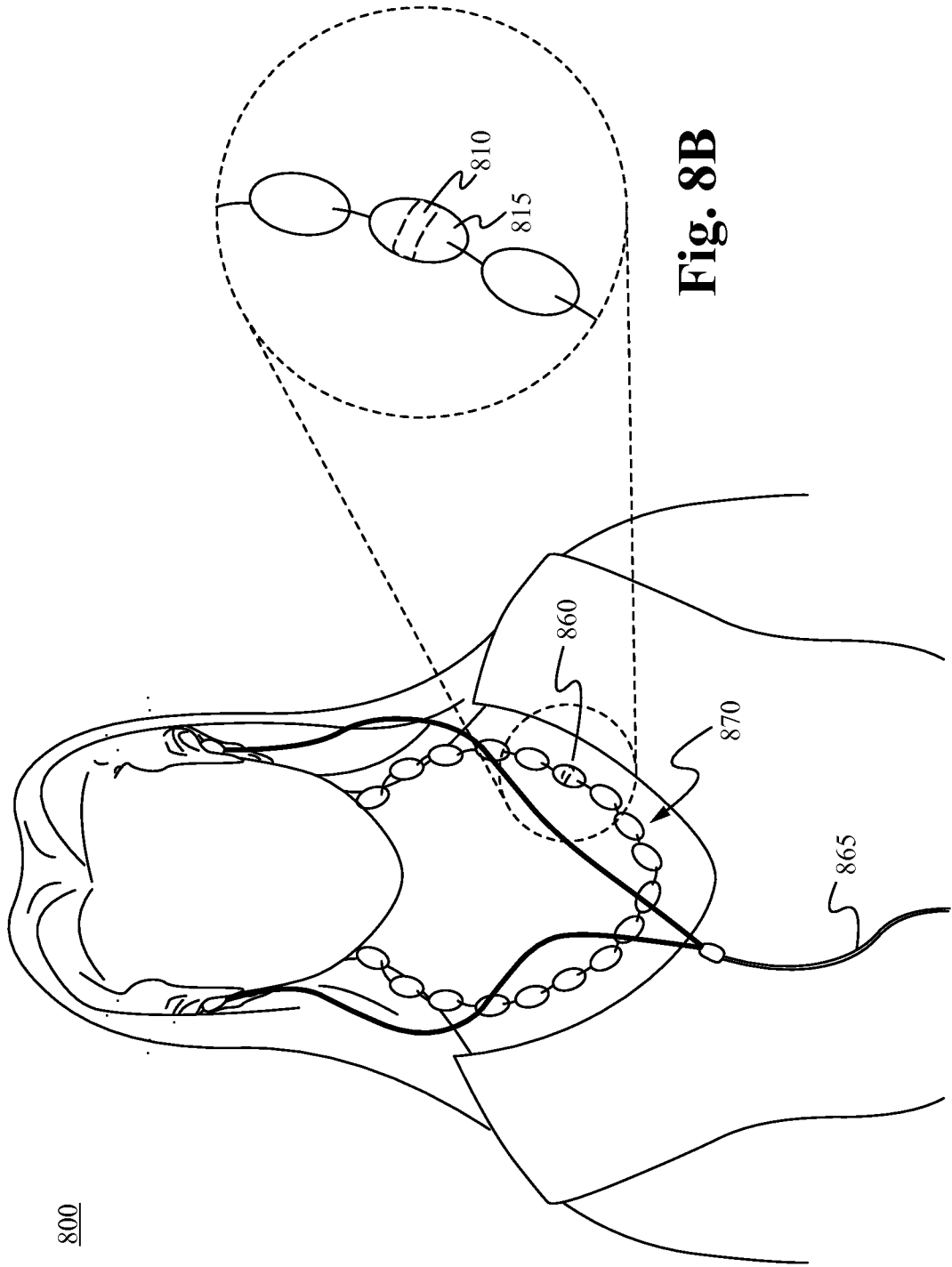

Fig. 8B

Fig. 8A

800

12/22

900

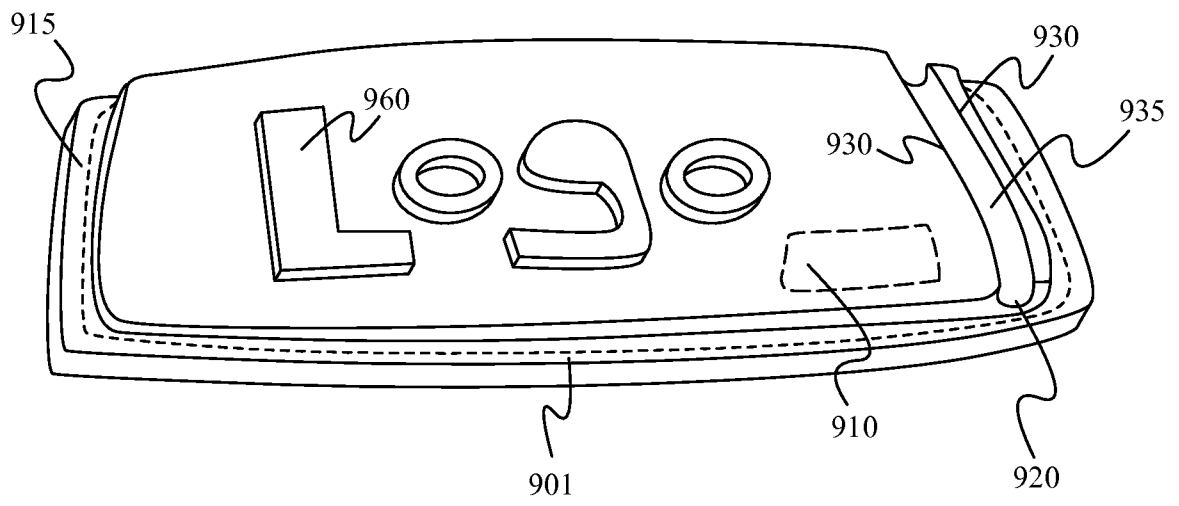

Fig. 9

1000

13/22

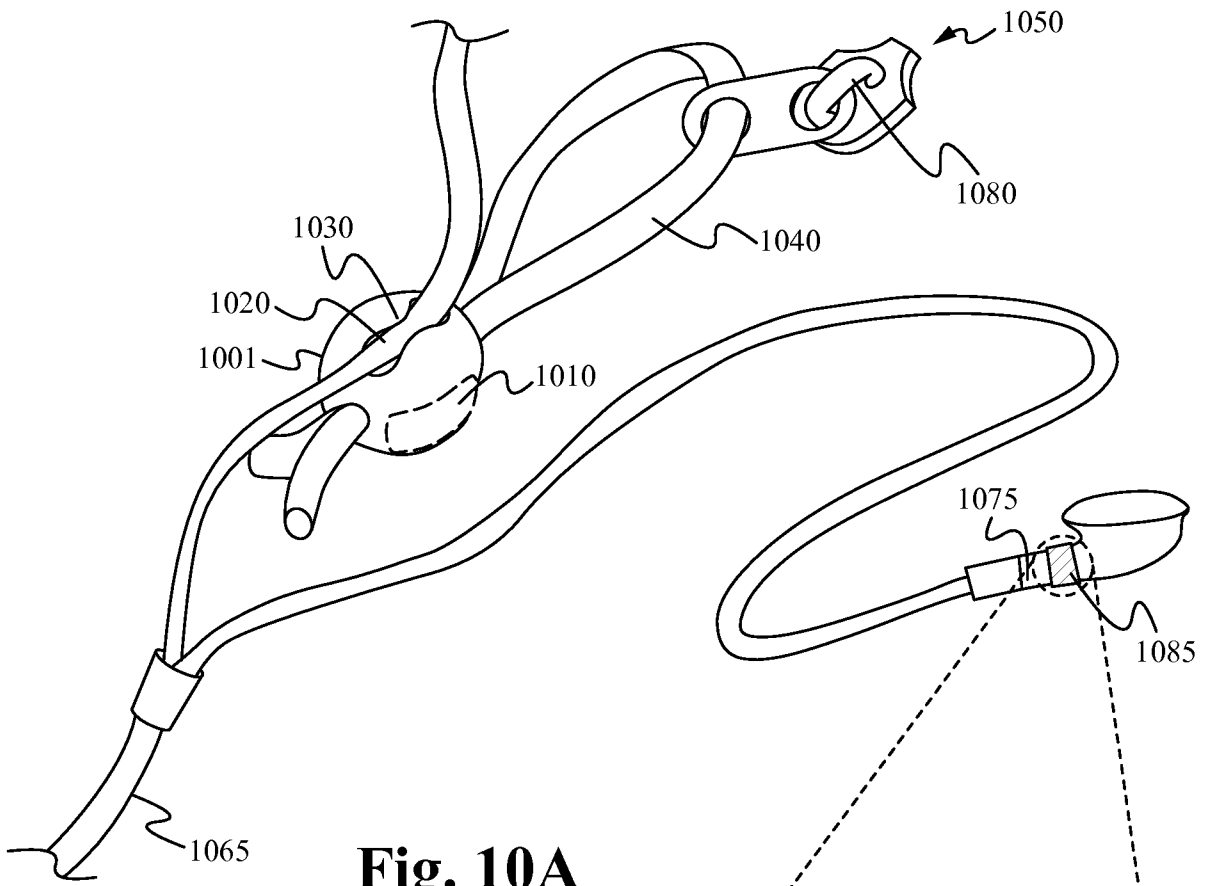

Fig. 10A

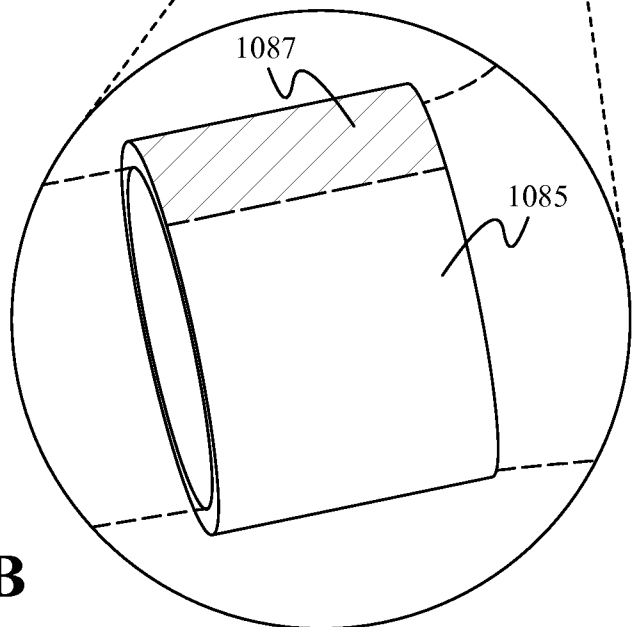

Fig. 10B

14/22

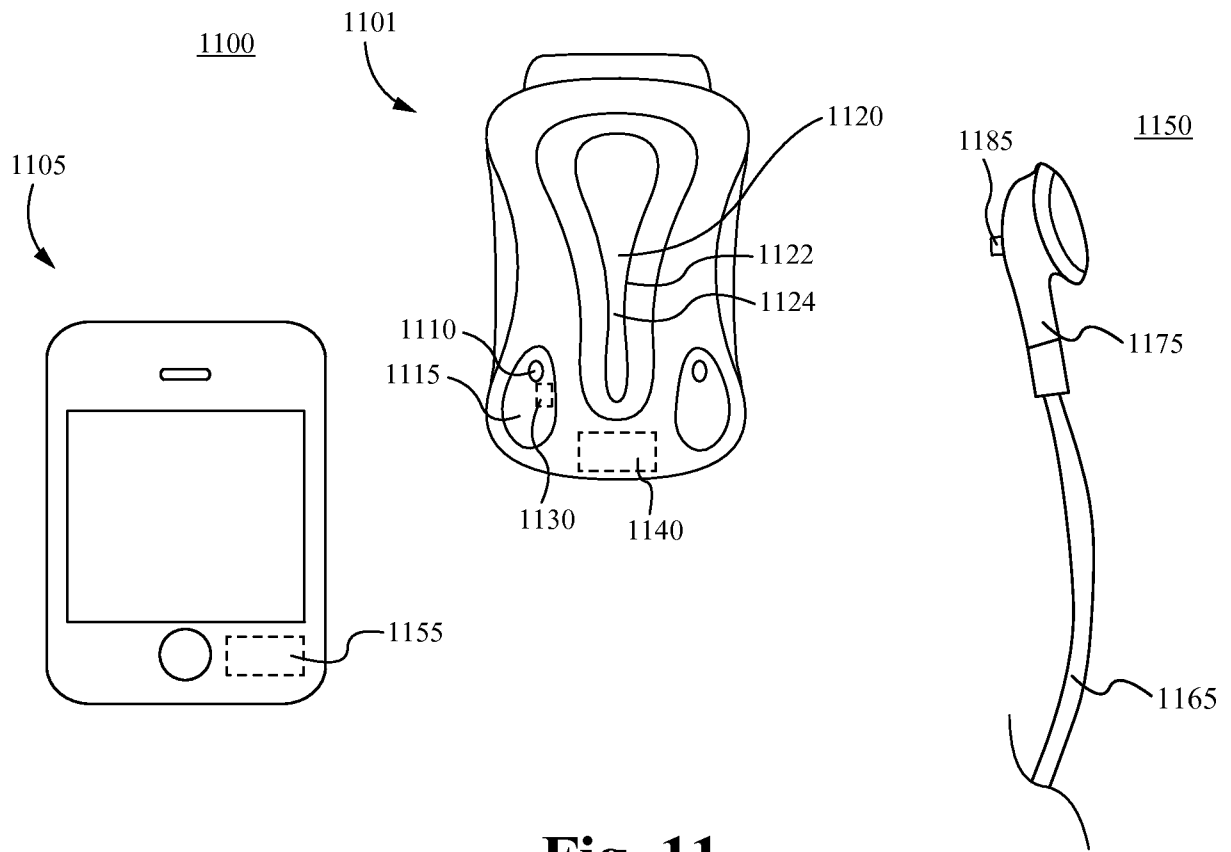

Fig. 11

1200

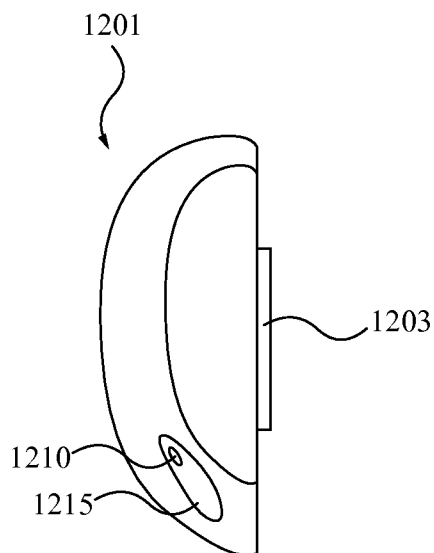

Fig. 12A

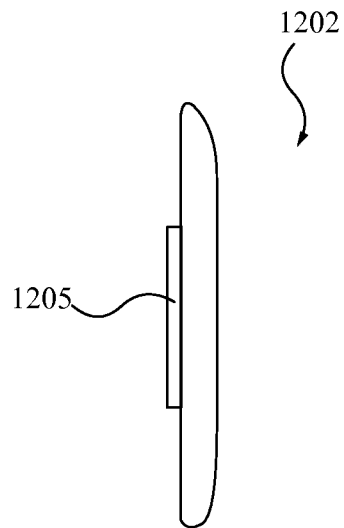

Fig. 12B

1300

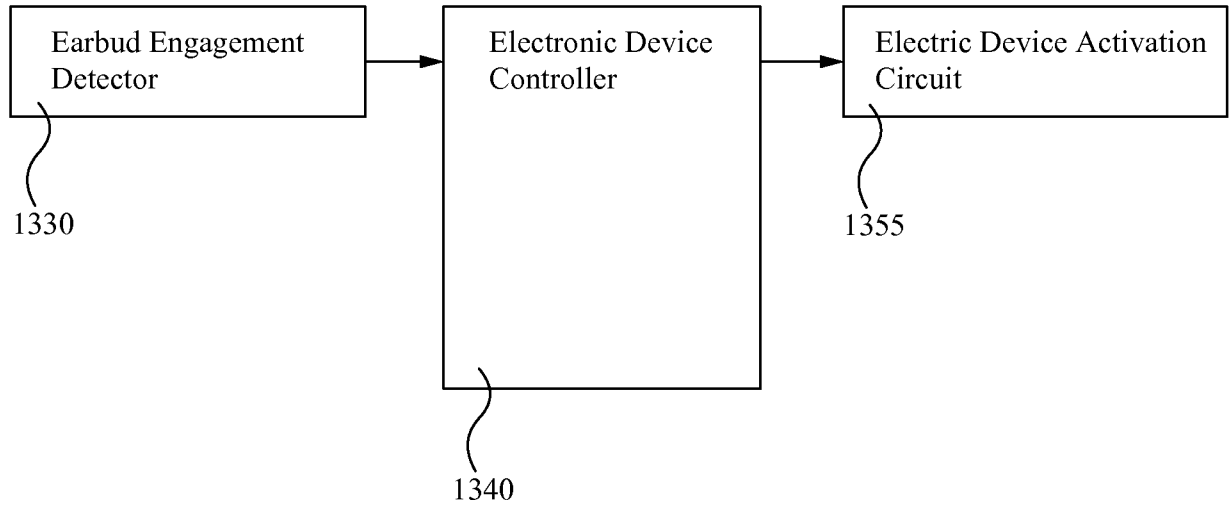

Fig. 13

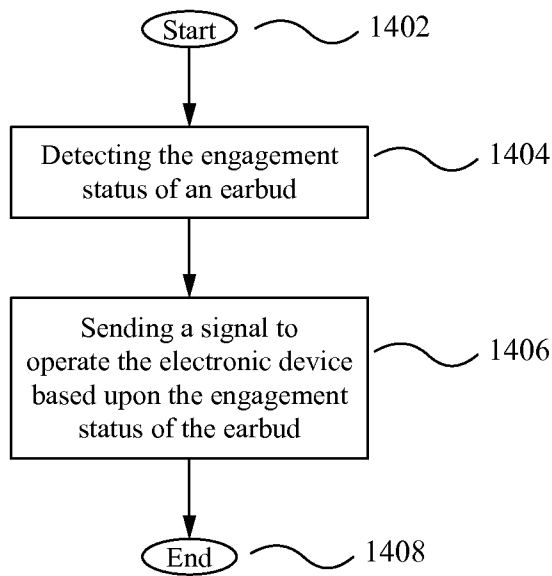

Fig. 14

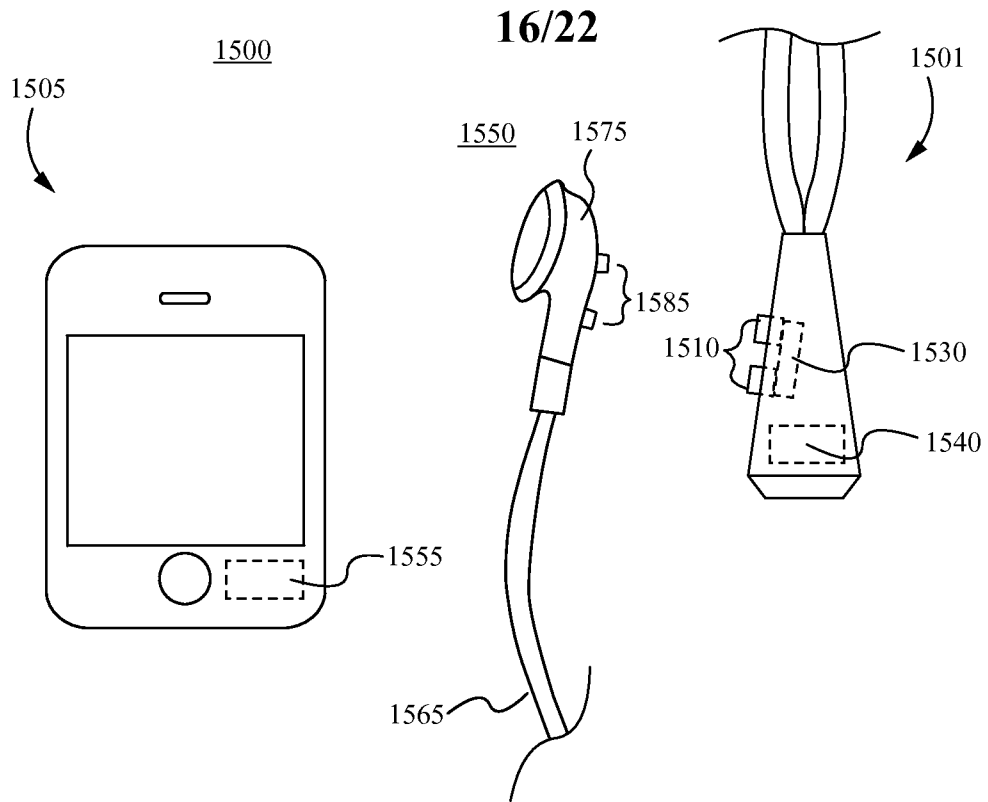

Fig. 15

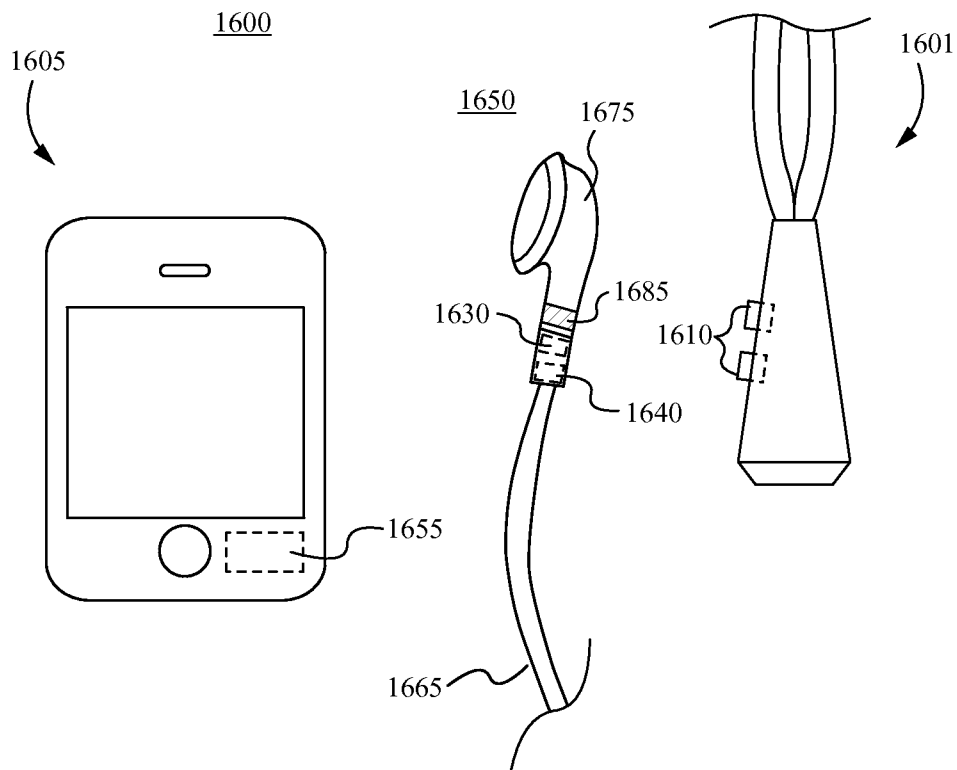

Fig. 16

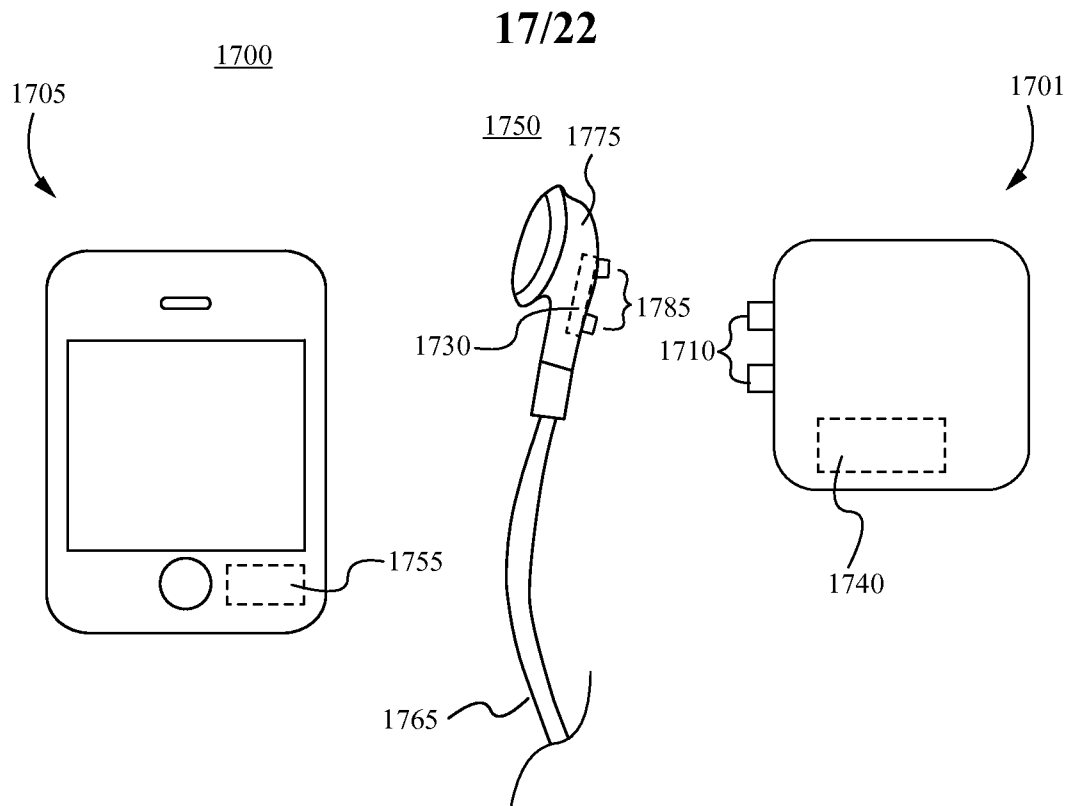

Fig. 17

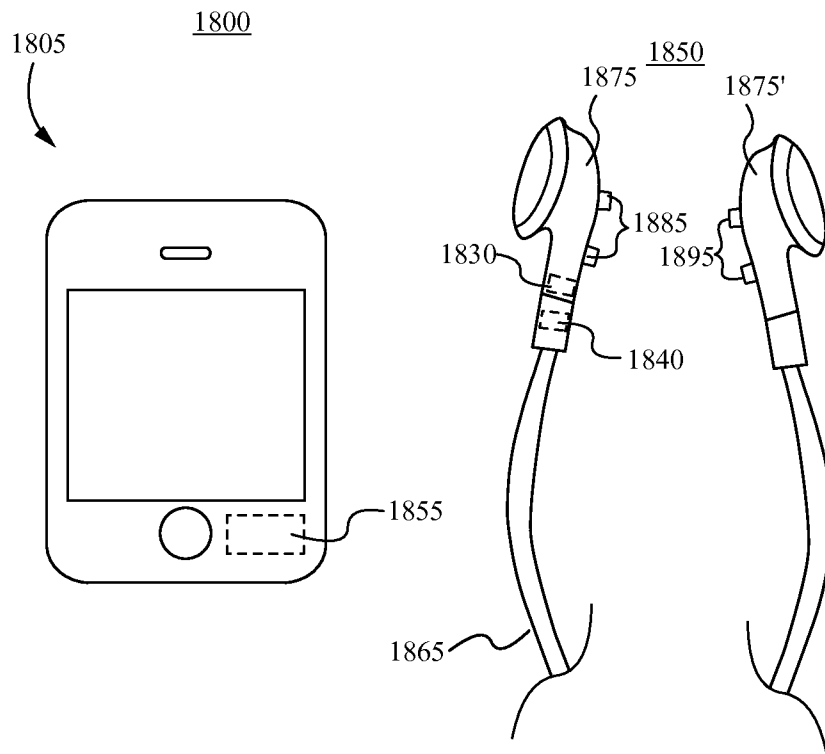

Fig. 18

18/22

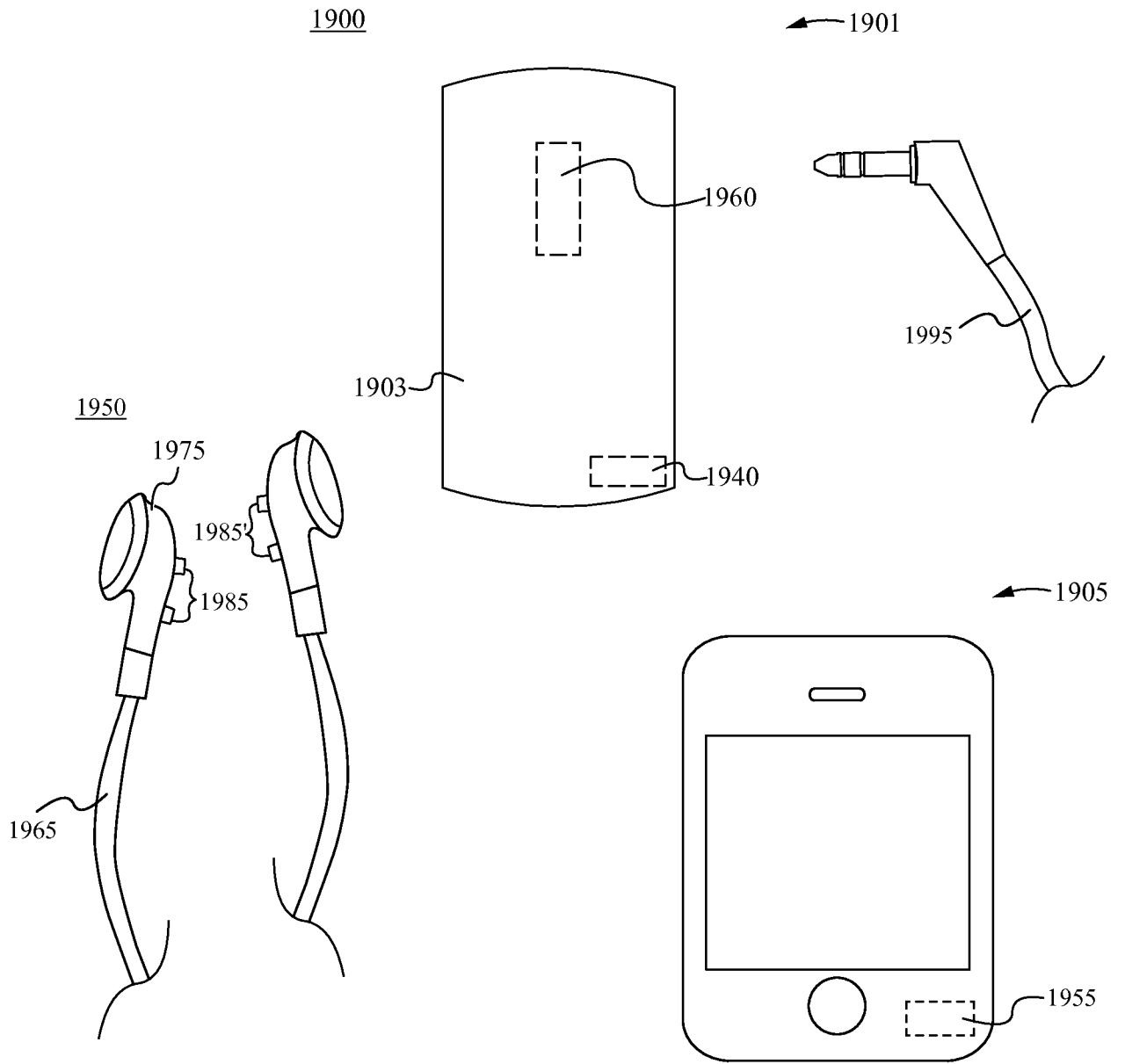

Fig. 19A

19/22

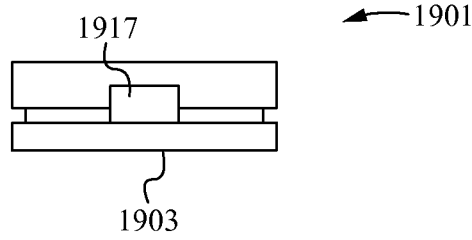

Fig. 19E

1901 →

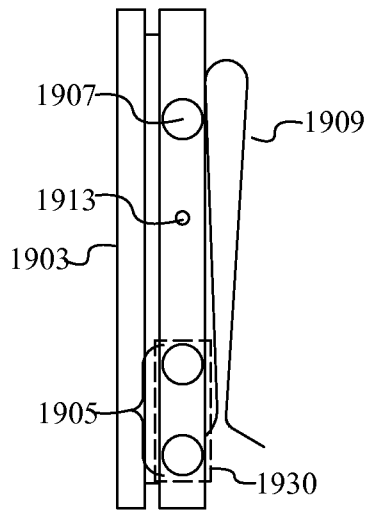

Fig. 19B

← 1901

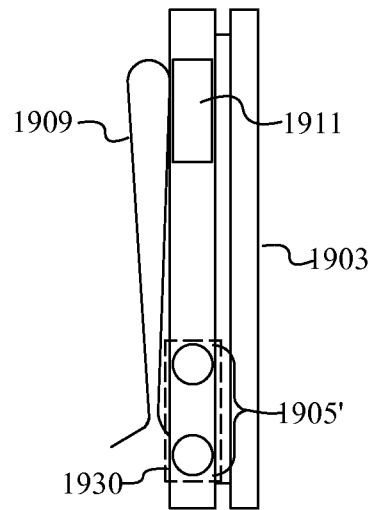

Fig. 19C

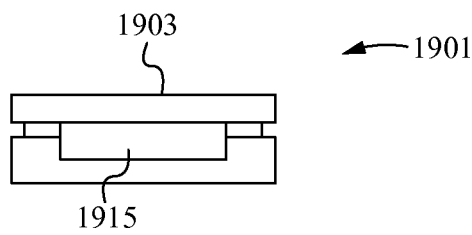

Fig. 19D

20/22

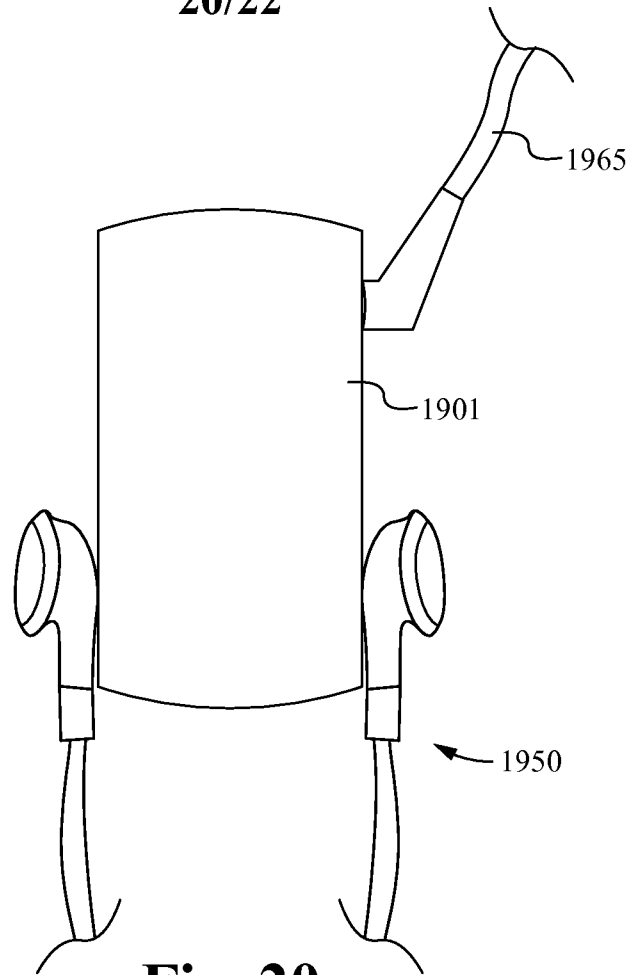

Fig. 20

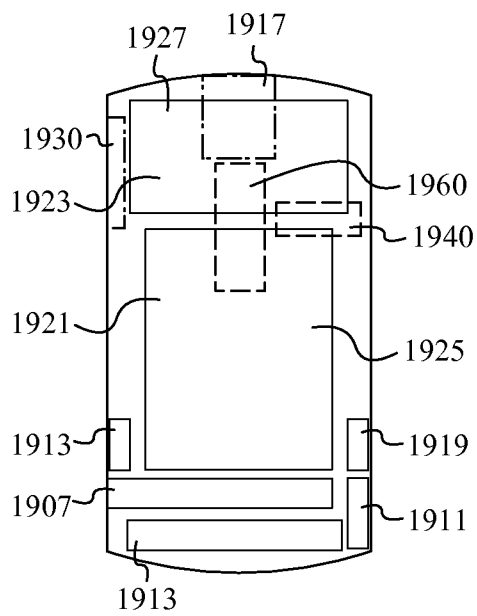

Fig. 21

21/22

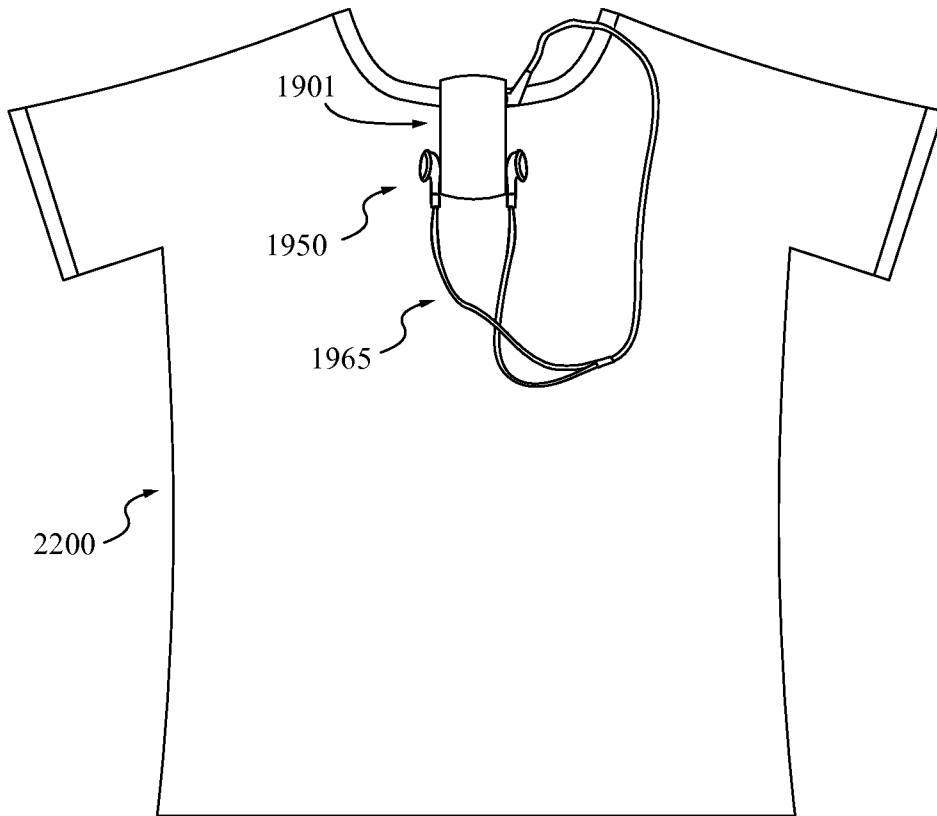

Fig. 22

22/22

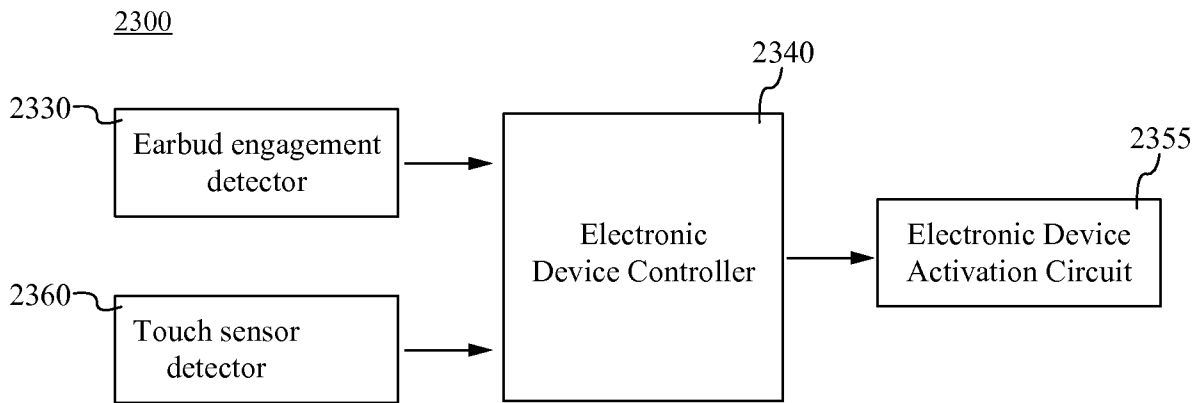

Fig. 23

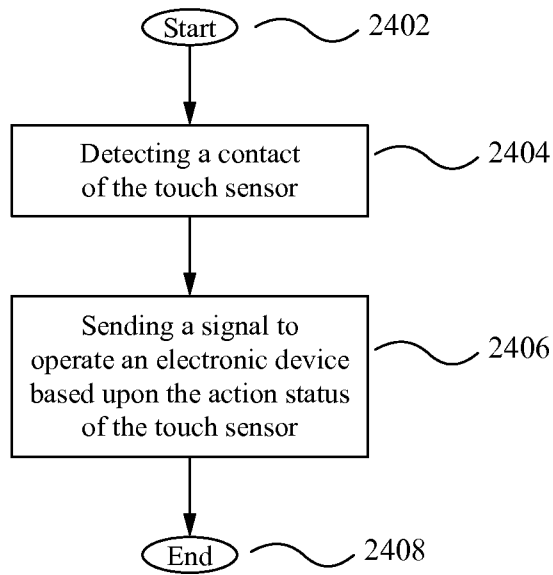

Fig. 24

INTERNATIONAL SEARCH REPORT

International application No.

PCT/US13/27297

A. CLASSIFICATION OF SUBJECT MATTER
 IPC(8) - G06F 15/16; B65D 85/86 (2013.01)
 USPC - 455/575.6; 381/322, 309
 According to International Patent Classification (IPC) or to both national classification and IPC

B. FIELDS SEARCHED

Minimum documentation searched (classification system followed by classification symbols)
 IPC (8) - B65D 85/00; B65B 5/00; G06F 15/16; B65D 85/86 (2013.01)
 USPC - 206/702, 719; 455/569.1, 575.2, 575.6; 381/322, 309

Documentation searched other than minimum documentation to the extent that such documents are included in the fields searched

Electronic data base consulted during the international search (name of data base and, where practicable, search terms used)
 MicroPatent (US Granted, US Applications, EP-A, EP-B, WO, JP, DE-G, DE-A, DE-T, DE-U, GB-A, FR-A); DialogPro (Derwent, INSPEC, NTIS, PASCAL, Current Contents Search, Dissertation Abstracts Online, Inside Conferences); Google/Google Scholar; Search terms used; ear-bud, earphone, headset, speaker, magnet, remove, holder, casing, clamp, attach

C. DOCUMENTS CONSIDERED TO BE RELEVANT

Category*	Citation of document, with indication, where appropriate, of the relevant passages	Relevant to claim No.
X --- Y	US 2010/0276315 A1 (CORRY, C) November 4, 2010; figures 3, 5 and 7A; paragraphs [0042 and 0050]; claim 10	1-3, 5, 8-15 --- 4, 6-7, 21
X --- Y	US 8,086,288 B2 (KLEIN, E) December 27, 2011; abstract; figures 1 and 4; column 9, lines 63-67	16-20 --- 4, 6-7, 21
A	US 2008/0240486 A1 (GARCIA, M et al.) October 2, 2008; whole document	1-21
A	US 2010/0022281 A1 (COHEN, A et al.) January 28, 2010; whole document	1-21

Further documents are listed in the continuation of Box C.

* Special categories of cited documents:

"A" document defining the general state of the art which is not considered to be of particular relevance	"T" later document published after the international filing date or priority date and not in conflict with the application but cited to understand the principle or theory underlying the invention
"E" earlier application or patent but published on or after the international filing date	"X" document of particular relevance; the claimed invention cannot be considered novel or cannot be considered to involve an inventive step when the document is taken alone
"L" document which may throw doubts on priority claim(s) or which is cited to establish the publication date of another citation or other special reason (as specified)	"Y" document of particular relevance; the claimed invention cannot be considered to involve an inventive step when the document is combined with one or more other such documents, such combination being obvious to a person skilled in the art
"O" document referring to an oral disclosure, use, exhibition or other means	"&" document member of the same patent family
"P" document published prior to the international filing date but later than the priority date claimed	

Date of the actual completion of the international search 14 June 2013 (14.06.2013)	Date of mailing of the international search report 25 JUN 2013
--	--

Name and mailing address of the ISA/US Mail Stop PCT, Attn: ISA/US, Commissioner for Patents P.O. Box 1450, Alexandria, Virginia 22313-1450 Facsimile No. 571-273-3201	Authorized officer: Shane Thomas PCT Helpdesk: 571-272-4300 PCT OSP: 571-272-7774
---	--

INTERNATIONAL SEARCH REPORT

International application No.

PCT/US13/27297

Box No. II Observations where certain claims were found unsearchable (Continuation of item 2 of first sheet)

This international search report has not been established in respect of certain claims under Article 17(2)(a) for the following reasons:

- 1. Claims Nos.:
because they relate to subject matter not required to be searched by this Authority, namely:

- 2. Claims Nos.:
because they relate to parts of the international application that do not comply with the prescribed requirements to such an extent that no meaningful international search can be carried out, specifically:

- 3. Claims Nos.:
because they are dependent claims and are not drafted in accordance with the second and third sentences of Rule 6.4(a).

Box No. III Observations where unity of invention is lacking (Continuation of item 3 of first sheet)

This International Searching Authority found multiple inventions in this international application, as follows:
See Extra Sheet.

- 1. As all required additional search fees were timely paid by the applicant, this international search report covers all searchable claims.
- 2. As all searchable claims could be searched without effort justifying additional fees, this Authority did not invite payment of additional fees.
- 3. As only some of the required additional search fees were timely paid by the applicant, this international search report covers only those claims for which fees were paid, specifically claims Nos.:
- 4. No required additional search fees were timely paid by the applicant. Consequently, this international search report is restricted to the invention first mentioned in the claims; it is covered by claims Nos.:
1-21

Remark on Protest

- The additional search fees were accompanied by the applicant's protest and, where applicable, the payment of a protest fee.
- The additional search fees were accompanied by the applicant's protest but the applicable protest fee was not paid within the time limit specified in the invitation.
- No protest accompanied the payment of additional search fees.

INTERNATIONAL SEARCH REPORT

International application No.

PCT/US13/27297

-Continued from Box III:

This application contains the following inventions or groups of inventions which are not so linked as to form a single general inventive concept under PCT Rule 13.1. In order for all inventions to be examined, the appropriate additional examination fee must be paid.

Group I: Claims 1-21 are directed toward a system for holding a set of earphones comprising holder body, magnets, and a magnetically attractable surface.

Group II: Claims 22-62 are directed toward an earphones holder comprising holder body, magnetically attractable surfaces, an earbud engagement detector, and an electronic device controller.

The common features of Groups I and II are at least a system for holding a set of earphones comprising holder body and a magnetically attractable surface. These common features are disclosed by US 2010/0276315 A1 to Corry. Corry discloses a system for holding a set of earphones comprising holder body (ear-bud holder 10, figure 1, paragraph [0037]) and a magnetically attractable surface (magnetic material, claim 10).

Since the common technical features are previously disclosed by the Corry reference, these common features are not special and so Groups I and II lack unity.