

(19) World Intellectual Property Organization
International Bureau



(43) International Publication Date
24 April 2003 (24.04.2003)

PCT

(10) International Publication Number
WO 03/032852 A2

- (51) International Patent Classification⁷: **A61B 17/72**
- (21) International Application Number: PCT/US02/33614
- (22) International Filing Date: 7 October 2002 (07.10.2002)
- (25) Filing Language: English
- (26) Publication Language: English
- (30) Priority Data:
09/982,152 17 October 2001 (17.10.2001) US
- (71) Applicant and
(72) Inventor: **BRAMLET, Dale, G.** [US/US]; 2044 Brightwaters Boulevard, NE, St. Petersburg, FL 33704 (US).
- (72) Inventors: **COSGROVE, Patrick, J.**; 12200 4th Street E, Treasure Island, FL 33706 (US). **SODEIKA, John, A.**; 11650 Harborside Circle, Largo, FL 33773 (US). **STERGHOS, Peter, M.**; 5291 40th Avenue N, St. Petersburg, FL 33709 (US).
- (74) Agent: **SLAVIN, Michael, A.**; McHale & Slavin, P.A., 4440 PGA Boulevard, Suite 402, Palm Beach Gardens, FL 33410 (US).
- (81) Designated States (*national*): AE, AG, AL, AM, AT, AU, AZ, BA, BB, BG, BR, BY, BZ, CA, CH, CN, CO, CR, CU, CZ, DE, DK, DM, DZ, EE, ES, FI, GB, GD, GE, GH, GM, HR, HU, ID, IL, IN, IS, JP, KE, KG, KP, KR, KZ, LC, LK, LR, LS, LT, LU, LV, MA, MD, MG, MK, MN, MW, MX, MZ, NO, NZ, OM, PH, PL, PT, RO, RU, SD, SE, SG, SI, SK, SL, TJ, TM, TN, TR, TT, TZ, UA, UG, UZ, VN, YU, ZA, ZM, ZW.
- (84) Designated States (*regional*): ARIPO patent (GH, GM, KE, LS, MW, MZ, SD, SL, SZ, TZ, UG, ZM, ZW), Eurasian patent (AM, AZ, BY, KG, KZ, MD, RU, TJ, TM), European patent (AT, BE, BG, CH, CY, CZ, DE, DK, EE, ES, FI, FR, GB, GR, IE, IT, LU, MC, NL, PT, SE, SK, TR), OAPI patent (BF, BJ, CF, CG, CI, CM, GA, GN, GQ, GW, ML, MR, NE, SN, TD, TG).
- Published:**
— *without international search report and to be republished upon receipt of that report*
- For two-letter codes and other abbreviations, refer to the "Guidance Notes on Codes and Abbreviations" appearing at the beginning of each regular issue of the PCT Gazette.*



WO 03/032852 A2

(54) Title: INTRAMEDULLARY HIP NAIL WITH BIFURCATED LOCK

(57) Abstract: The intramedullary nail system includes an intramedullary nail for insertion in the femur. The nail has an axial bore and an intersecting transverse bore. A lag screw is inserted through the transverse bore and turned into the head of the femur. A slotted sleeve is inserted over the lag screw and through the transverse bore with the slots aligned with the axial bore. A sleeve lock is inserted into the axial bore and has a locking tab which engages the slots in the sleeve preventing rotational and longitudinal movement between the sleeve and the nail. A compression screw is turned into the trailing end of the lag screw and engages the encircling sleeve to provide longitudinal translation between the lag screw and sleeve to apply compressive force across a fracture.

1 Intramedullary Hip Nail with Bifurcated Lock

2

3 This application is a continuation-in-part of U. S.
4 application S. N. 09/841,851, filed April 24, 2001.

5

6 FIELD OF THE INVENTION

7 The present invention generally relates to an intramedullary
8 system for coupling first and second bone portions across a
9 fracture therebetween and, more specifically, to an
10 intramedullary hip pinning system for rigidly interconnecting a
11 femoral head to the remaining portion of the femur and across a
12 fracture in the area of the femoral neck.

13 BACKGROUND OF THE INVENTION

14 The intramedullary nail was introduced in the 1930's. This
15 device was inserted into the intramedullary canal of the femur
16 resulting in immediate fixation of fractures, early mobilization of
17 the patient, and a lower morbidity and mortality. A number of
18 nails have been introduced for fracture fixation about the femur in
19 proximal end, including the Jewett Nail and Enders Nail.

20 Intramedullary nails were also inserted down the entire
21 length of the femoral canal to provide a basis for the construct.
22 Threaded wires, standard bone screws or cannulated bone screws were
23 then inserted through or along side the proximal nail and into the
24 femoral head to provide fixation and rotational stability.
25 Compression of the proximal bone fragments against each other was
26 not available and in longer nails the distal tip of the nail tends
27 to rotate out of plane which forces the surgeon to locate the
28 distal screw holes using fluoroscopy by a method commonly known as
29 "free-handing".

30 In the 1960s, the compression hip screw was introduced,
31 resulting in improved fixation of the proximal femur. A lag screw
32 assembly was inserted into the femoral head, a plate was attached
33 to the lateral femur, and a compression screw joined the two.
34 These implants provided a more rigid structure for the patient and

1 allowed the surgeon to compress the fractured fragments against
2 each other thereby decreasing the time to mobility. A number of
3 compression hip screws have been introduced for fracture fixation
4 about the proximal femur.

5 During implantation typical compression hip screws require an
6 incision at least equal to the length of plate being used which
7 extends operative time and blood loss. The side plate also creates
8 a protuberance on the lateral side which provides an annoyance to
9 the patient. Compression hip screw systems also fail to provide
10 adequate compression in osteogenic patients because the lag screw
11 threads fail to obtain sufficient purchase due to poor bone stock.
12 Poor purchase is known to contribute to nonunion, malunion and the
13 lag screw assembly eroding through the superior bone of the head of
14 the femur in a condition known as "cut out". Additionally, many
15 patients are dissatisfied with the results of compression hip screw
16 surgery because of the excessive sliding to a medial displacement
17 and shortening position which leads to a change in gait.

18 Newer devices and inventions explored additions to the nail
19 and lag screw assembly to improve the fixation and ease or
20 eliminate the need to locate the distal screw holes. These newer
21 devices are commonly classified as "expanding devices" and expand
22 in size, after placement, to fill the intramedullary cavity.
23 Freedland, U.S. Patent No.s 4,632,101, 4,862,883 and 4,721,103,
24 Chemello, U.S. Patent No. 6,077,264 and Davis, U.S. Patent No.
25 5,057,103 describe a method of fixation which provides points which
26 contact the internal cortical wall. In these patents a mechanism
27 is actuated deploying arms or anchor blades through the cancellous
28 bone to contact the inner cortical wall. These methods are
29 complex, do not deploy through the cortical bone and are difficult
30 to retract should the nail or lag screw assembly require
31 extraction.

32 Other expanding devices provide surface contact with the
33 internal cortical wall resulting in a wedge effect. Kurth, U.S.
34 Patent No. 4,590,930, Raftopoulos, U.S. Patent No. 4,453,539 and
35 Aginski, U.S. Patent No. 4,236,512 among others have described

1 mechanisms which deploy or expand with a molly bolt concept. These
2 methods are complex and difficult to retract should the nail or lag
3 screw assembly requires extraction and do not deploy through the
4 cortical bone.

5 Bolesky, U.S. Patent 4,275,717, was the first to discuss
6 engagement within the cortical wall. However, Bolesky's invention
7 does not address controlled penetration into the wall and required
8 permanent implantation of the actuation rod. In addition, Bolesky
9 does not address the fundamental problem of the actuation rod's
10 protrusion extramedullary into the surrounding musculature.

11 In earlier patents, U.S. Patent No.s 5,976,139 and 6,183,474
12 B1, both incorporated herein by reference, Bramlet describes a
13 surgical anchor which has deployable tangs. These tangs are simple
14 in design, internally positioned, yet easily deployed into, and if
15 desired through, the cortical bone providing improved purchase for
16 compression of a fracture; especially in osteogenic bone. These
17 tangs are just as easily retracted should the device require
18 explantation.

19 In 1988 Lawes, et. al., U.S. Patent No. 5,176,681, disclosed a
20 method of combining desirable aspects of both intramedullary nails
21 and compression hip screws. Lawes described a method for joining
22 the lag screw and nail to resist loosening or moving of the lag
23 screw during the operation. Approximately 10 years ago Howmedica
24 (Rutherford, New Jersey, United States) was the first to produce
25 the "Gamma Nail", named for its similarity in shape to the Greek
26 letter, as an intramedullary hip compression screw device and other
27 designs
28 soon followed.

29 In 1990 Durham, et. al., U.S. Patent No. 5,032,125, disclosed
30 an intramedullary hip compression screw system which incorporated a
31 sleeve for slidably receiving the lag screw. A set screw was then
32 used to engage the sleeve thereby preventing translation and
33 rotation of the sleeve. This device allowed for reduction of the
34 proximal fragment using the same method as conventional hip screw
35 assemblies. Shortly thereafter Smith & Nephew Richards (Memphis,

1 Tennessee, United States) produced the "Intramedullary Hip
2 Compression Screw".

3 These intramedullary hip compression screw systems required a
4 few small incisions, allowed capture of the most proximal fragments
5 of the femur, rigid fixation of the most proximal and distal
6 fragments, and a sliding lag screw assembly which allows reduction
7 of the fragments as the patient ambulates or begins to bear weight
8 on the fractured limb. These nails are typically held in place on
9 the distal end through interference forces with the intramedullary
10 canal and through the use of locking screws.

11 The typical intramedullary hip compression screw's shape
12 accommodates the relative shape of the greater trochanter and
13 femoral shaft, neck and head fragments. Therefore, the shape of
14 the hip is preserved. Indications for use of a compression hip
15 screw are expanded because fractures to the subtrochanteric region
16 of the proximal femur, as well as reverse obliquity fractures can
17 be treated more efficiently. Additionally, the bulk of an
18 intramedullary hip screw blocks excessive sliding of the proximal
19 fragment.

20 Current intramedullary compression hip screw systems
21 continue to suffer from some of the same problems exhibited in
22 those of its predecessors. Osteogenic bone still provides a poor
23 medium for purchase of the lag screw assembly thread inhibiting
24 adequate compression and rotational stability. Longer nails
25 continue to see the distal tip of the nail rotating out of plane
26 forcing the surgeon to locate the distal screw holes by the free-
27 hand method. The free-handing technique leads to an increased
28 surgical time and exposes the surgeon and patient to increased
29 radiation dosages.

30 Current intramedullary compression hip screw systems also
31 provide new limitations that hamper their effectiveness. One such
32 limitation is evident in both Lawes' and Durham's designs. These
33 designs require the use of a set screw to prevent rotation of the
34 lag screw; the set screw in the Lawes patent interacts directly
35 with the lag screw, while Durham's is indirect with the lag screw.

1 To ensure proper mating takes place the Smith & Nephew Richards'
2 systems provides a torque wrench, while Howmedica's system requires
3 tightening of the set screw to full engagement and then backing it
4 off. Over time, loss of calibration of the torque wrench and
5 improper engagement by the surgeon user could lead to an
6 unsatisfactory engagement and decreased usefulness.

7 Clearly a need exists for a system that is superior to the
8 conventional compression hip screws while minimizing the surgical
9 insult to the human body.

10

11 SUMMARY OF THE INVENTION

12 Therefore, it is an object of this invention to teach a
13 simple, effective and controllable fixation device which allows
14 greater purchase of the lag screw assembly within the femoral head
15 resulting in improved compression across the fracture line.

16 It is another object of this invention to teach a system with
17 rotational stability both in the femoral head and in the femoral
18 shaft, and that offers to minimize, if not eliminate the need for
19 additional distal incisions to locate and place locking screws.

20 It is yet another objective of this invention to teach an
21 intramedullary hip nail system that provides for a more positive,
22 and more repeatable engagement mechanism for allowing the lag screw
23 to slide during fracture reduction and healing.

24 It is a further objective of this invention to teach a system
25 designed to allow the surgeon a choice of penetration distance
26 within the femoral head and femoral shaft fixation based upon the
27 injuries presented and the desired level of treatment.

28 It is a still further objective of this invention to teach a
29 system that allows explantation to occur as easily as implantation.

30 An intramedullary nail system for coupling first and second
31 bone portions across a fracture therebetween may be provided as a
32 kit of several assembled subassemblies. The subassemblies of the
33 intramedullary nail system according to the invention are combined
34 for installation within the medullary canal of a fractured bone,
35 such as a femur.

1 In one embodiment of the present invention, the
2 intramedullary nail system includes an intramedullary nail body
3 having an internally threaded trailing end and a leading end with
4 portals which allow passage of cortical screws. The nail body has
5 a transverse bore near the trailing end in communication with the
6 cannulated axial bore for receiving a lag screw assembly. The lag
7 screw assembly has a leading end with an externally threaded
8 portion with portals which allow passage of anchoring tangs and
9 internally deployable and retractable anchoring tangs. The lag
10 screw assembly has internal threads on the trailing end. A slotted
11 sleeve slidably passes through the transverse clearance bore of
12 intramedullary nail and freely telescopes over the lag screw
13 assembly while preventing rotation of lag screw assembly, but
14 allowing axial translation of the lag screw. A compression screw
15 has a shoulder contacting the trailing end of the slotted sleeve
16 and engages the internal threads of the lag screw assembly trailing
17 end providing axial translation of the lag screw assembly within
18 the sleeve. A sleeve lock passes through the axial bore of the
19 intramedullary nail and along the slotted sleeve through its
20 slot(s) thereby preventing rotation and axial translation of the
21 sleeve, but allowing axial translation of the lag screw assembly.
22 An end cap assembly with external threads engages the internal
23 threads of the trailing end of the intramedullary nail.

24 A preferred embodiment combines the intramedullary nail, the
25 sleeve lock and the end cap assembly into an intramedullary nail
26 assembly. When presented as such, the surgeon or surgical
27 assistant

28 will not have to enjoin these items during the surgical procedure.

29 The end cap assembly preferably contains a patch of ultra-
30 high molecular weight poly-ethylene (UHMWPE) within the threads.
31 This provides constant positive engagement between the end cap
32 external threads and the intramedullary nail internal threads.

33 With the intramedullary nail placed into position within the
34 intramedullary canal the lag screw assembly is then placed into
35 position in a manner consistent with common technique. The unique

1 tang assembly is actuated and the tangs are deployed to any desired
2 position thereby achieving the desired level of fixation based upon
3 the quality of the bone.

4 The lag screw assembly preferably contains a permanently
5 placed anchoring tang assembly stored in a retracted position
6 within the leading end. The tangs are deployed or retracted from
7 the trailing end of the lag screw assembly.

8 The slotted sleeve is coaxially inserted over the lag screw
9 assembly's trailing end and through the intramedullary nail. The
10 slotted sleeve is aligned to accept the sleeve lock.

11 The sleeve lock is actuated via a mechanism in the
12 intramedullary nail insertion instrument. The sleeve lock moves
13 from its primary position to its final position. In its final
14 position the sleeve lock passes through the slotted sleeve slots
15 preventing rotation and axial translation of the slotted sleeve.

16 The compression screw passes through the sleeve and engages
17 the lag screw assembly. As the compression screw is tightened
18 the lag screw assembly and associated first bone portion are
19 pulled against the intramedullary nail and second bone portion
20 resulting in compressive forces being applied across the
21 fracture.

22 The compression screw preferably contains a patch of ultra-high
23 molecular weight poly-ethylene (UHMWPE) within the threads. This
24 provides constant positive engagement between the compression screw
25 external threads and the lag screw assembly internal threads.

26 The cortical screws are then placed into position through
27 the bone and through the intramedullary nail in a manner consistent
28 with common technique.

29 In another embodiment of the present invention the
30 intramedullary nail system includes a intramedullary nail with
31 portals at the leading end which allow passage of cortical screws
32 and/or anchoring tangs. When the intramedullary nail is placed
33 into position the anchoring tang assembly is actuated to deploy the
34 tangs out from their stowed position into the cortical bone. The
35 tangs are deployed to any desired position thereby achieving a

1 desired fixation and rotation prevention based upon the quality of
2 the bone. Should the system require additional load carrying
3 capability, cortical screws may be placed to enjoin the
4 intramedullary nail with the surrounding cortical bone.

5 The intramedullary nail of this alternate embodiment is
6 preferably cannulated to allow passage of one or more anchoring
7 tang assemblies. These anchoring tang assemblies are inserted from
8 the trailing end towards the leading end and the tangs deployed by
9 means of an actuator driver. An alternate embodiment of the
10 intramedullary nail has a retracted anchoring tang assembly, which
11 is permanently placed within the leading end of the intramedullary
12 nail and is deployed or retracted by means of an actuator driver
13 from the trailing end of the intramedullary nail.

14 The anchoring tang assembly contains arcuate shaped tangs
15 that are permanently attached to the assembly's main body. These
16 tangs are initially formed into a prescribed position for storage.
17 As the assembly is actuated, and the tangs deploy, the tangs are
18 formed into their final shape through interaction with the portal
19 of either the intramedullary nail or the lag screw assembly.

20 The lag screw assembly preferably contains a permanently
21 placed anchoring tang assembly stored in a retracted position
22 within the leading end. The tangs are deployed or retracted from
23 the trailing end of the lag screw assembly.

24 The anchoring tang assembly within the lag screw is similar
25 in design to that within the intramedullary nail in that it
26 contains arcuate shaped tangs that are permanently attached to the
27 assembly's tang body. These tangs are initially formed into a
28 prescribed position for storage. As the assembly is actuated, and
29 the tangs deploy, the tangs are formed into their final shape
30 through interaction with the portal of either the intramedullary
31 nail or the lag screw assembly.

32 The end cap preferably contains a patch of ultra-high
33 molecular weight poly-ethylene (UHMWPE) within the threads. This
34 provides constant positive engagement between the end cap external
35 threads and the intramedullary nail internal threads. In its final

1 position the end cap locks the sleeve and inhibits the sleeve from
2 sliding or rotating out of a prescribed position.

3 The intramedullary nail system may be supplied as a kit with
4 subassemblies to be combined into the complete system during the
5 surgical procedure.

6 DESCRIPTION OF THE DRAWINGS

7

8 FIG. 1, is a longitudinal view of the preferred embodiment

9 Intramedullary Nail System in an exploded state;

10 FIG. 2, is a view, partially in longitudinal cross section, of the

11 Intramedullary Nail System placed in the intramedullary canal

12 of a fractured bone using cortical screws as a method of

13 fixation;

14 FIG. 3, is an enlarged, cross section view of the proximal portion

15 of the Intramedullary Nail System in FIG. 2;

16 FIG. 4, is an enlarged view of the proximal portion of the

17 Intramedullary Nail System of FIG. 2;

18 FIG. 5, is an enlarged view of the proximal portion of the

19 Intramedullary Nail System of FIG. 3;

20 FIG. 6, is a top view of the Intramedullary Nail System of FIG. 2;

21 FIG. 7, is a top view of FIG. 8;

22 FIG. 8, is an isometric view of the Sleeve Lock;

23 FIG. 9, is a front view of FIG. 8;

24 FIG. 10, is a side view of FIG. 8;

25 FIG. 11, is an isometric view of the Slotted Sleeve;

26 FIG. 12, is a top view of FIG. 11;

27 FIG. 13, is a section view of FIG. 11;

28 FIG. 14, is a front view of FIG. 11;

29 FIG. 15, is a side view of FIG. 11;

30 FIG. 16, is an isometric view of the End Cap Assembly;

31 FIG. 17, is a top view of FIG. 16;

32 FIG. 18, is a side view of FIG. 16;

33 FIG. 19, is a top view of FIG. 21;

34 FIG. 20, is a section view of FIG. 21;

1 FIG. 21, is a front view of the Intramedullary Nail;
2 FIG. 22, is an enlarged, partial side view of FIG. 21;
3 FIG. 23, is an isometric view of the Snap Ring;
4 FIG. 24, is a top view of FIG. 22;
5 FIG. 25, is a view, partially in longitudinal cross section, of the
6 alternate embodiment Intramedullary Nail System placed in the
7 intramedullary canal of a fractured bone using cortical
8 screws as a method of fixation;
9 FIG. 25A, is an enlarged view of the distal portion, of the
10 alternate embodiment Intramedullary Nail System in FIG. 25
11 using the talon as a method of fixation;
12 FIG. 26, is an enlarged view of the distal portion, of the alternate
13 embodiment Intramedullary Nail System in FIG. 25 during Tang
14 Assembly deployment;
15 FIG. 27, is an enlarged, partial view of the Tang Actuator Assembly of
16 FIG. 26;
17 FIG. 28, is an enlarged view of the stowed Tang Assembly from FIG. 25A;
18 FIG. 29, is an enlarged proximal view of the alternate embodiment
19 Intramedullary Nail System of FIG. 25;
20 FIG. 30, is an enlargement of the Tang Assembly in FIG. 32;
21 FIG. 31, is a front view of the deployed Tang Assembly;
22 FIG. 32, is a front view of the stowed Tang Assembly;
23 FIG. 33, is an isometric view of the alternate embodiment Sleeve
24 Lock;
25 FIG. 34, is a top view of FIG. 33;
26 FIG. 35, is a front view of FIG. 33; and
27 FIG. 36, is a cross section view of FIG. 33

28

29 DETAILED DESCRIPTION

30 The individual components of the assembly, as illustrated in
31 Fig.1, are constructed of implantable grade stainless steel alloys
32 in the preferred embodiment but could also be constructed of
33 implantable grade titanium alloys or polymeric materials such as
34 nylon, carbon fibers and thermoplastics, as well. These components
35 consist of the lag screw assembly 4, the nail body 1, the sleeve 3,

1 the compression screw 6, the end cap 8, snap ring 7, sleeve lock 2
2 and the cortical screws 5 (Fig. 1).

3 . The lag screw assembly 4 is described in detail in U.S. Patent
4 6,183,474 B1, as is compression screw 6. The external features of
5 the lag screw assembly 4 are indicated in Fig. 4 and include the
6 threads 28, the tang 12, the body 30 and the flats 29 on the body 30.
7 The threads 28 engage the cancellous bone within the femoral head on
8 the proximal side of the fracture line; the tang body 23' carries the
9 tang 12 which is also located on the proximal side of the fracture
10 line and engages cortical bone as shown in Fig. 2 deployed in the
11 femur. However, the tang 12 is fully retracted into the body of the
12 lag screw in its as-delivered state and remains that way until the
13 lag screw assembly is fully positioned within the femoral head. When
14 deployed in the femoral head, the tang 12 extends through exit
15 hole 40' and penetrates the cortical bone, greatly increasing purchase
16 axial fixation and rotational stability of the lag screw assembly.
17 The tang is fully reversible if removal of the lag screw is ever
18 required. The body 30 of lag screw assembly 4 has with two flats 29
19 180 degrees apart (Fig. 4) which interfaces with bore 38 and end
20 configuration flats 17 (Figs. 11, 12, 13) of the sleeve 3 in such a way
21 as to allow axial translation or slide of the lag screw while
22 preventing rotation relative to the sleeve 3. This sliding prevents
23 penetration of the femoral head by the proximal end of the lag screw
24 as the fracture compresses from patient load bearing.

25 The nail body 1 is designed for antegrade insertion into the
26 intramedullary canal of the femur. It is anatomically shaped to
27 the axis of the canal and has a mediolateral bend angle H (Fig.
28 20). The proximal outside diameter A of the body is greater than
29 the distal outside diameter E due to narrowing of the canal and to
30 allow the lag screw cylindrical clearance bore 33 (Fig. 20) to be
31 large enough to pass the thread 28 of the lag screw assembly 4 and
32 provide a sliding fit to the outside diameter of the sleeve 3 .
33 The axis of clearance bore 33 is at an angle V with respect to the
34 proximal diametral axis (Fig. 2). This angle V allows proper
35 positioning of lag screw assembly 4 within the femoral head. The

1 nail proximal bore 32, distal bore 31 and distal end bore 24 are of
2 circular cross section. Bores 32, 31 and distal end bore 24 are
3 sized to permit a clearance and sliding fit, respectively, with a
4 guide pin (not illustrated) during installation of the nail body 1
5 into the intramedullary canal. The clearance holes 25 of nail
6 body 1 pass through the distal outside surface and wall of the
7 nail body 1, into the distal bore 31 and continue on the same axis
8 through the opposite wall and outer diameter. Their diameter is
9 such as to allow passage of the threaded portion of the cortical
10 screw 5. (Fig.2). The nail body 1 is secured both in axial
11 translation and rotation within the intramedullary canal by
12 cortical screws 5 when they are installed through the lateral
13 cortex, clearance holes 25, and the medial cortex of the femur as
14 illustrated in Fig. 2.

15 The internal threads 37 (Fig. 20) at the proximal end of the
16 nail body 1 provide for instrument interface and end cap 8
17 retention. The threads 37 are used for attachment of a nail
18 removal instrument (not shown). The internal threads 37 also engage
19 the external threads 15 (Fig. 16) of end cap 8. A slot 26 (Fig. 19,
20 22) extends through the proximal nail body wall and internal
21 threads 37 breaking into the nail proximal bore 32. Slot 26 is
22 utilized for instrument interface and instrument and end cap 8
23 anti-rotation. The sleeve lock anti-rotation groove 36 (Fig. 19,
24 20) is located in the nail proximal bore 32 and 180 degrees around
25 the nail body proximal diameter from slot 26. Groove 36 extends
26 from the surface of the nail proximal internal bore 32 into the
27 nail proximal wall a given constant depth but not through the wall.
28 It extends axially a given distance, through threads 37 and exits
29 the proximal end of nail body 1 (Fig. 19, 20). Also located in the
30 nail body 1 proximal bore 32, are proximal circumferential groove
31 34 and distal circumferential groove 35 (Fig. 20).

32 The sleeve lock 2 (Fig. 1), has a basic cylindrical cross
33 section with two integral locking tabs 10 (Figs. 8, 9,10). Each
34 locking tab 10 has a semi-circular cross section, with the radius
35 being the same as that of the cylindrical body section. A

1 circumferential groove 14 is located in the cylindrical body
2 section and is sized to accept snap ring 7 (Fig. 1). An anti-
3 rotation tab 11 (Figs.7, 8, 9, 10) is an integral part of sleeve
4 lock 2, which protrudes radially and axially from the cylindrical
5 body section and is sized for a sliding fit within nail body 1
6 anti-rotation groove 36. A threaded bore 13 (Figs. 7,8) extends
7 axially through the cylindrical body section. The outside diameter
8 of sleeve lock 2 is sized for a sliding fit with proximal bore 32
9 of nail body 1.

10 The snap ring 7 (Fig. 1), is a toroid of circular cross section
11 with an outside diameter B and inside diameter C (Figs. 23, 24) a
12 gap 41 is provided in the circumference of snap ring 7 to allow
13 radial flexure which either increases or decreases diameters B and
14 C depending on the direction of force. The snap ring 7 is sized in
15 such a way as to loosely fit within groove 14 of sleeve lock 2
16 (Figs. 9, 10). When installed into groove 14 snap ring diameter B
17 is larger than the outside diameter of sleeve lock 2, however, if
18 compressed, diameter B becomes equal or less than the outside
19 diameter of sleeve lock 2.

20 The end cap 8 (Fig. 1) is of a cylindrical cross section with a
21 threaded outside diameter 15 and threaded internal bore 16
22 (Fig.16). Two compound anti-rotation grooves run axially in the
23 outside diameter and are located radially 180 degrees apart. The
24 grooves consist of two sections 20 and 50 (Figs. 16,17,18).
25 Section 20 extends into, but not through the wall of end cap 8
26 whereas section 50 extends through the wall and breaks into
27 threaded bore 16. The outside threads of end cap 8 are sized to
28 interface with nail body 1 internal threads 37.

29 The nail body 1, sleeve lock 2, snap ring 7 and end cap 8 may be
30 pre-assembled by the manufacturer and supplied to surgery as a kit
31 assembly. The pre-assembly consists of the following steps: the
32 snap ring 7 is expanded and placed into groove 14 of sleeve lock 2.
33 The sleeve lock/snap ring assembly inserts into proximal bore 32 of
34 nail body 1 with locking tabs 10 leading. Since the outside
35 diameter B of

1
2 snap ring 7 is greater than the nail body 1 proximal bore 32, snap
3 ring 7 will stop when it contacts the proximal end of nail body 1.
4 The sleeve lock/snap ring assembly is then rotated axially to align
5 the sleeve lock anti-rotation tab 11 with nail body anti-rotation
6 groove 36. The sleeve lock/snap ring assembly is inserted further
7 into nail body 1 proximal bore 32 at which time bore 32 acts on
8 snap ring 7 compressing it within groove 14 of sleeve lock 2
9 allowing the sleeve lock/snap ring assembly to slide in bore 32 and
10 sleeve lock anti-rotation tab 11 to engage nail body 1 sleeve lock
11 anti-rotation groove 36. As insertion continues, snap ring 7
12 encounters nail body 1 proximal circumferential groove 34 at which
13 time snap ring 7 assumes its original diameter B as it expands into
14 circumferential groove 34, locking or "detenting" the sleeve lock 2
15 in this position. Additional insertion force causes the snap ring
16 7 diameter B to interact with bore 32 compressing it back into
17 sleeve lock 2 groove 14, allowing the sleeve lock/snap ring
18 assembly to slide in bore 32 towards nail body 1 distal
19 circumferential groove 35. Upon contacting circumferential groove
20 35, snap ring 7 will expand into groove 35 locking or "detenting"
21 the sleeve lock 2 in this position. With the sleeve lock 2 in this
22 position, end cap 8 can be threaded into nail body 1 internal
23 threads 37 with groove section 20 leading. The end cap 8 is
24 installed until its trailing end is as close to flush with the nail
25 body 1 proximal end as practical with the end cap 8 slots 20/50
26 aligned radially with nail body 1 instrument interface slot 26 and
27 nail body 1 anti-rotation slot 36. The sleeve lock 2, is now pulled
28 from its "detented" position, with snap ring 7 located at
29 distal circumferential groove 35 (Fig. 20), by use of an instrument
30 (not shown) passed through end cap threaded bore 16 and threaded
31 into sleeve lock 2 threaded bore 13. The force causes snap ring 7
32 to be compressed into sleeve lock 2 groove 14 which allows sleeve
33 lock 2 to translate towards proximal circumferential groove 34. As
34 sleeve lock 2 translates, anti-rotation tab 11 slides in nail body
35 1 sleeve lock anti-rotation groove 36 thus preventing relative

1 rotation between sleeve lock 2 and the nail body 1. Since end cap
2 8 slots 20/50 were aligned with nail body 1 sleeve lock anti-
3 rotation slot 36, sleeve lock anti-rotation tab 11 is aligned with
4 end cap 8 slots 20/50. As sleeve lock 2 continues to translate
5 towards end cap 8, sleeve lock anti-rotation tab 11 enters/mates
6 with end cap slots 20/50 and snap ring 7 enters nail body proximal
7 circumferential groove 34 "detenting" sleeve lock 2 into position.
8 With sleeve lock 2 in this position, nail body anti-rotation slot
9 36, sleeve lock tab 11 and end cap slots 20/50 are in a mated
10 condition (Fig. 6). This prevents any relative rotation of nail
11 body 1, sleeve lock 2 and end cap 8 during handling or attachment
12 of the installation instrumentation. The nail assembly is supplied
13 for surgery in this condition. This pre-assembled condition saves
14 surgical time over current intramedullary nail systems that require
15 an end cap and setscrew to be added during surgery.

16 Sleeve 3 (Fig.1) is utilized to secure lag screw assembly 4 into
17 nail body bore 33 after implantation of the lag assembly 4 and nail
18 body 1 in the femur. The outside diameter D (Fig.12) is sized for
19 a sliding fit in bore 33. The sleeve 3 has a circular bore 38 and
20 a small length of bore having oppositely disposed flats 17 at the
21 leading end (Figs.11,12,13). These are sized for a sliding fit
22 with the body 30 and flats 29 of lag screw assembly 4 thus allowing
23 axial translation of lag screw assembly 4 but not allowing relative
24 rotation. The sleeve 3 contains two locking slots 9 (Figs. 11,
25 14), which continue through sleeve 3 wall thickness and are located
26 opposite each other (180 degrees radially) on the sleeve 3 body.
27 These slots 9 are comprised of two features in addition to the
28 opening into the sleeve bore 38. They are the flats 39 and the
29 anti-translation bosses 18. The distance X (Fig. 14) between flats
30 39 of each slot 9 is sized for a sliding fit in the space Y between
31 locking tabs 10 of sleeve lock 2 (Fig. 9). The anti-rotation
32 bosses 18 are configured and spaced in such a way as to provide a
33 sliding fit when sleeve 3 and sleeve lock 2 are mated at a relative
34 angle V as shown in Fig. 5. The locking slots 9 configuration
35 still functions when angle V is varied over a small range. A

1 counterbore 19 is provided in the end of sleeve 3 opposite that of
2 the flats 17 and has the configuration as shown in Fig. 13. It is
3 sized and configured for mating with compression screw 6 as shown
4 in Fig. 2.

5 The nail assembly consisting of nail body 1, sleeve lock 2, snap
6 ring 7 and end cap 8 is inserted in an antegrade fashion into the
7 femur. Prior to insertion, an instrument is attached to the
8 proximal end of the nail assembly. The instrument (not shown)
9 utilizes the threaded bore 16 of end cap 8 for attachment and
10 incorporates a protruding feature which mates simultaneously with
11 slot 26 of nail body 1 and slot 50 of end cap 8. This provides
12 angular alignment between the instrument and the nail body 2 and
13 provides anti-rotation of end cap 8 within nail body 1 during
14 attachment/torquing of the instrument into threaded bore 16 of end
15 cap 8. The nail assembly is inserted into the femur and the lag
16 screw assembly 4 is then inserted through nail body bore 33.
17 Instrumentation assures proper insertion depth of lag screw
18 assembly 4 and alignment of the plane of lag screw flats 29
19 parallel to the nail body proximal bore 32 longitudinal axis. After
20 the lag screw 4 is implanted in its proper position within the
21 femur, its trailing end protrudes partially or fully through nail
22 body 1 bore 33. The leading end of sleeve 3 containing flats 17
23 is inserted into bore 33 and the bore 38 of sleeve 3 aligned, with
24 the aid of instrumentation (not shown) with the similarly shaped
25 lag screw body 30. The sleeve 3 is inserted further into bore 33
26 thus mating with lag screw 4. Since, as described previously,
27 sleeve flats 17 interact with lag screw flats 29 preventing
28 relative rotation between lag screw 4 and sleeve 3 and the plane of
29 lag screw flats 29 are already aligned parallel to nail proximal
30 bore 32 longitudinal axis the plane of the sleeve flats 39
31 are now also aligned parallel with the nail proximal bore 32
32 longitudinal axis. Instrumentation (not shown) has also located the
33 centerline of sleeve 3 slots 9 coincident to the longitudinal axis
34 of nail body proximal bore 32 and therefore also coincident with
35 sleeve

1 locking tab 10 longitudinal axis. The sleeve lock 2, snap ring 7,
2 sleeve 3 and lag screw 4 are now in the relative positions as shown
3 in Fig. 4.

4 The sleeve lock 2 and snap ring 7 are now translated by
5 instrumentation (not shown), as previously described, such that
6 snap ring 7 moves from nail body proximal circumferential groove 34
7 to nail body distal circumferential groove 35 and sleeve locking
8 tabs 10 mate into sleeve slots 9 as shown in Fig. 5. With sleeve
9 3, sleeve lock 2, snap ring 7 and lag screw 4 assembled as shown in
10 Fig. 5 within nail body 1, sleeve 3 is fixed in rotation by
11 interaction of locking tabs 10 and sleeve flats 39 and in
12 translation by interaction of locking tabs 10 with sleeve anti-
13 translation bosses 18. Since sleeve 3 is now fixed in rotation, lag
14 screw 4 is also fixed in rotation by the interaction of sleeve
15 flats 17 and lag screw flats 29 but not fixed in translation. The
16 end cap 8 remains in position and is utilized to prevent bony
17 ingrowth into nail body internal threads 37, which are used for
18 removal instrument interface, if nail assembly removal is required
19 in the future.

20 With sleeve 3 and lag screw 4 fixed in rotation, tangs 12 of lag
21 screw 4 can be deployed as described in U.S. Patent 6,183,474 B1.
22 After tang 12 deployment, compression screw 6 is inserted through
23 bore 38 of sleeve 3 mating its threaded end with internal threads
24 within lag screw 4 and its head with sleeve counterbore 19. As
25 compression screw 6 is tightened, its head contacts sleeve
26 counterbore 19, and since sleeve 3 is fixed in translation by
27 locking tabs 10, lag screw 4 is drawn toward nail body 1 thereby
28 compressing the fracture.

29 One or two cortical screws 5 can now be used to fix nail body 1
30 both in translation and rotation within the intramedullary canal.
31 The cortical screws 5 are placed through the lateral femoral cortex
32 and through clearance holes 25 in the nail body 1, then through the
33 medial femoral cortex (Fig. 2).

34 The nail assembly can be removed by removing cortical screws 5,
35 compression screw 6, retracting tangs 12, as described in detail in

1 U.S. Patent 6,1834,74 B1, removing end cap 8, releasing sleeve 2 by
2 translating sleeve lock 2 and snap ring 7 to nail body proximal
3 circumferential groove 34, removing sleeve 2 and lag screw 4 and
4 utilizing nail body internal threads 37 to interface a nail body 1
5 removal instrument (not described) and pull the nail body from the
6 intramedullary canal.

7 In an alternate kit embodiment (Fig. 25), sleeve lock 2, end cap
8 8 and snap ring 7 are replaced by sleeve lock assembly 42 (Fig.
9 33). The alternate configuration of sleeve lock 42 results in the
10 nail body 1 not requiring sleeve lock anti-rotation groove 36,
11 proximal and distal circumferential grooves 34 and 35. In this
12 embodiment, no implant components are assembled into the nail body
13 1 prior to its insertion into the femur.

14 End cap assembly 42 consists of two parts, end cap 43 and
15 bifurcated sleeve lock 44 (Fig. 33). The end cap 43 contains drive
16 interface 46 (Fig. 34) which provides a means to drive the end cap
17 with an instrument and an external thread 49 (Fig. 35) sized to
18 interface with nail body internal thread 37 (Fig. 20). The
19 bifurcated sleeve lock 44 incorporates a cylindrical peened
20 interface 48 (Fig. 36) which protrudes through a clearance hole in
21 end cap 43 and into drive interface 46 where it is peened over in
22 such a way as to retain end cap 43 to bifurcated sleeve lock 44 but
23 allow relative rotation of the two parts. Locking tabs 47 have a
24 semicircular cross section with a radius equal to that of the body
25 of the bifurcated sleeve lock 44 sized to provide a sliding fit in
26 proximal bore 32 of nail body 1 and a width sized to provide a
27 sliding fit between sleeve anti-rotation bosses 18 when the parts
28 are assembled at angle V as shown in Fig. 29. Angle V can vary
29 over a range and the fit will still be maintained. Distance Z (Fig.
30 35) is such as to provide a sliding fit over dimension X of sleeve
31 3.

32 Unlike the preferred embodiment, sleeve lock assembly 42 is not
33 pre-assembled into nail body but is instead installed as a last
34 step in the procedure. The nail body 1 is inserted into the
35 intramedullary canal of the femur, the lag screw 4, sleeve 3,

1 compression screw 6 are installed as well as the cortical screws 5.
2 The nail body 1 insertion instrument (not shown) is then removed
3 from the proximal end of nail body 1 and the locking tab 47 (Fig.
4 33) end of sleeve lock assembly 42 is inserted into the proximal
5 bore 32 of the nail body 1. It must be manipulated to align with
6 sleeve 3 slots 9. Note that this manipulation could be eased through
7 the addition of a keying feature between the bifurcated sleeve lock
8 44 and the nail proximal bore 32. Once aligned, locking tabs 47
9 will enter and mate with sleeve slots 9 allowing the sleeve lock
10 assembly to translate far enough for threads 49 of end cap 43 to
11 mate with nail body internal threads 37. Since the peened interface
12 between end cap 43 and bifurcated sleeve lock 44 allow relative
13 rotation, drive interface 46 can be used to fully engage threads 49
14 and 37. The sleeve is now fixed in rotation and translation as
15 previously described. The nail assembly can be removed by
16 reversing the assembly order.

17 This alternate embodiment also allows another method for
18 rotational and translational locking of the nail assembly distally
19 in the intramedullary canal. Instead of cortical screws 5, use of a
20 distal tang 55 would be optional (Fig.25A). Note that this distal
21 tang 55 would have to be inserted prior to the installation of the
22 sleeve 3, lag screw assembly 4 and compression screw 6.

23 In this embodiment, the distal end of nail body 1 would
24 incorporate an end hole of square cross section 27 (Fig. 25A) and
25 four tang exit holes 40 in addition to the cortical screw holes 25.
26 Distal bore 31 is sized to permit a sliding fit with the tang body
27 58 (Fig. 31). Four tang exit holes 40 (Fig. 28) are located on a
28 90 degree radial spacing penetrating from the distal outside
29 diameter E into the distal bore 31, on axes which form an angle J
30 (Fig. 25A). The clearance holes 25 pass through the distal outside
31 surface and wall into the distal bore 31 and continue on the same
32 axis through the opposite wall and outer diameter. Their diameter
33 is such as to allow passage of the threaded portion of the cortical
34 screw 5 (FIG.1). A frustro-conical feature 59 (Fig. 25A) provides
35 a transition between the circular bore 31 and the square bore 27.

1 The square bore 27 serves three purposes. It provides clearance
2 through the leading end of the nail body for passage of a guide
3 pin, used during fracture alignment and installation of the of the
4 nail body into the intramedullary canal, it provides a sliding fit
5 for the square forward protrusion 23 (Fig. 31) of tang 3, and it
6 acts as a "vent" hole for any organic material within the bore 31
7 which is being pushed ahead of the tang during tang installation.
8 It must be noted that the forward most clearance holes 25 also
9 intersect the frustro-conical feature 59 and will act as vents for
10 organic material during tang insertion after the square protrusion
11 23 has engaged and filled square bore 27.

12 The tang 55 has four equally sized and radially spaced legs which
13 are preformed to radius R. The radius R (Fig. 32) on each leg 21
14 results in a dimension between the trailing ends of opposing legs
15 which is greater than the outside diameter of tang body 58 and the
16 bore diameter 31 of nail body 2. The tang body 58 is circular in
17 cross section and sized for a sliding fit within nail body bore 31
18 with a leading edge chamfer 57 which transitions into the leading
19 protrusion 23 which has a square cross section and leading end taper
20 56. Tang body 58 contains an internally threaded bore 22 which is the
21 instrument interface for the instrument 51 used to insert and deploy
22 the tang. It must be noted that threaded bore 22 is not needed for
23 tang retraction. Fig. 31 illustrates the deployed shape of tang 55
24 which is the shape it assumes after the legs 21 have been forced
25 through the tang exit holes 40 of nail body 1.
26 Insertion/deployment of the tang 55 occurs after insertion of the
27 nail body into the intramedullary canal. The insertion/deployment
28 instrument 51 (Fig. 27) has threads 52 that are mated with tang 55
29 threaded bore 22. The tang 55 is now inserted through nail body bore
30 32 and into nail body bore 31. The insertion/deployment instrument
31 51 has a self-centering bushing 53 to help orient the tang 55 for
32 proper insertion. Since the distance between opposing tang legs 21 is
33 greater than the bore diameter 31 due to radius R, the interference
34 with bore 31 forces the legs 21 inward in an elastic manner and
35 insertion continues with some resistance. As the tang travels down

1 bore 31, any organic material which has accumulated in bore 31 is
2 pushed ahead and forced out through square bore 27 of nail body 1 and
3 through cortical screw clearance holes 25. Further insertion causes
4 the tang 55 leading square taper 56 to contact the square bore 27 of
5 the nail body 1. Since both cross sections are square, no engagement
6 will occur until they are radially aligned which may or may not occur
7 without some slight rotation of the tang 55 using the
8 insertion/deployment instrument 51 (Fig. 27). After alignment occurs
9 and by virtue of this alignment, the tang leading protrusion 23 will
10 slide freely in square bore 27 and the tang legs 21 and the nail body
11 1 tang exit holes 40 will now be aligned. The tang 55 continues past
12 tang exit holes 40 and is fully inserted when the tang body leading
13 edge chamfer 57 makes contact with the nail body frustro-conical
14 feature 59 at point K (Fig. 28). In this position, the leading
15 end of tang 55 protrudes through the end of nail body 1 to point N
16 and the trailing end of the tang legs 21 are just past tang exit
17 holes 40. The tang is now in position to be deployed. To deploy the
18 tang, an axial force is exerted by the insertion/deployment
19 instrument 51 in the opposite direction as for insertion. This
20 causes the tang 55 to translate back up bore 31 and the sharp ends of
21 tang legs 21 to encounter tang exit holes 40. Since the tang legs 21
22 were elastically compressed inward by bore 31 they will now spring
23 outward forcing the sharp end of tang legs 21 into tang exit holes
24 40. Further translation of the tang 55 forces the tang legs through
25 the tang exit holes 40. Due to the diameter and angle of the tang
26 exit holes 40, the tang legs 21 are formed in such a manner as to
27 emerge almost perpendicular to the femoral cortex (Fig. 25A).
28 Continued translation of the tang 55 causes the tang legs 21 to
29 penetrate the femoral cortex. During this time, tang leading square
30 protrusion 23 is still engaged by the nail body square bore 27 thus
31 preventing rotation of tang 55 in bore 31 during deployment and
32 preventing unwanted twisting of the tang legs 21. The tang 55 can be
33 deployed fully or partially and is self-locking in any position due
34 to the almost perpendicular entry angle into the femoral cortex.
35 After deployment, the insertion /deployment instrument 51 is

1 unthreaded from tang threaded bore 25 and removed. The nail body 1
2 is now fixed axially and rotationally in the intramedullary canal.
3 Fig. 26 shows the tang 55 in the fully deployed position having
4 translated a distance from point N (Fig. 28) to point M (Fig. 26).
5 The tang 55 is fully retractable. It is retracted by applying a
6 force on the tang 55 with instrumentation in the opposite direction
7 as deployment until the tang 55 comes to rest at points K and N as
8 shown in Fig. 28.

9 Note that at the surgeon's discretion, distal fixation of the
10 nail body 1 can still be accomplished without use of tang 55. This
11 is accomplished by using the cortical screws 5 (Fig. 1) as
12 described in the preferred embodiment. The cortical screws 5 are
13 placed through the lateral femoral cortex and through clearance
14 holes 25 in the nail body 1, and through the medial femoral cortex
15 (Fig. 25). The cortical screws are not used in conjunction with
16 distal tang fixation and cannot be passed through clearance holes
17 25 if there is a tang 55 inserted into nail body 1.

18 It should be noted that this description is directed at only
19 one possible alternate embodiment and that many others are possible
20 ending with the same results without departing from the spirit and
21 scope of the invention. As examples, tang 55 could have any number
22 of legs 21, square protrusion 23 could take on any keyed polygon
23 shape, sleeve lock 2 could be made with 1 leg 10 and the lag screw
24 may or may not have tangs.

25

26

27

28

29

30

31

32

33

34

35

1

2 We Claim:

3

4 1. An intramedullary nail for insertion in the intramedullary
5 canal of a long bone comprising a nail body having a leading end
6 and a trailing end, said trailing end having an axial bore and an
7 intersecting transverse clearance bore, said body having at least
8 one portal therethrough near said leading end adapted to receive at
9 least one anchor extending through said leading end to secure said
10 nail body in the intramedullary canal.

11

12 2. An intramedullary nail as claimed in claim 1 wherein said at
13 least one portal is a clearance hole and said at least one anchor
14 is a cortical screw.

15

16 3. An intramedullary nail as claimed in claim 1 wherein said axial
17 bore extends into said leading end, said at least one portal is an
18 exit hole from said axial bore through said nail body, said at
19 least one anchor includes a tang body disposed in said axial bore
20 in said leading end, said tang body having at least one tang
21 adapted to extend through said exit hole to secure said nail body.

22

23 4. An intramedullary nail as claimed in claim 3 wherein said
24 leading end includes at least one clearance hole adapted to receive
25 a cortical screw.

26

27 5. An intramedullary nail as claimed in claim 1 wherein a lag
28 screw assembly is adapted to slidably extend through said
29 transverse clearance bore, said lag screw assembly having a body
30 with a leading end and a trailing end, said leading end having
31 external threads for purchase in bone.

32

33

1 6. An intramedullary nail as claimed in claim 5 wherein said lag
2 screw body has an axial bore and said external threads include at
3 least one exit hole from said bore, a tang body disposed in said
4 bore, said tang body having at least one tang adapted to extend
5 through said at least one exit hole to increase purchase of said
6 lag screw assembly.

7

8 7. An intramedullary nail as claimed in claim 5 wherein said axial
9 bore extends into said leading end, said at least one portal is an
10 exit hole from said axial bore through said nail body, said at
11 least one anchor includes a tang body disposed in said axial bore
12 in said leading end, said tang body having at least one tang
13 adapted to extend through said at least one exit hole to secure
14 said nail body.

15

16 8. An intramedullary nail as claimed in claim 5 wherein a sleeve
17 lock is movably disposed at a first position in said axial bore
18 between said trailing end and said transverse clearance bore, said
19 sleeve lock having at least one locking tab extending toward said
20 transverse clearance bore in said axial bore.

21

22 9. An intramedullary nail as claimed in claim 8 wherein a sleeve
23 having a tubular sidewall is adapted to slidably extend through
24 said transverse clearance bore around said lag screw assembly, said
25 side wall of said sleeve having at least one slot therein, and said
26 at least one locking tab engaging said at least one slot when said
27 sleeve lock is moved to a second position in said axial bore.

28

29 10. An intramedullary nail as claimed in claim 9 wherein said
30 trailing end of said lag screw assembly and said sleeve are
31 approximately co-terminus, said co-terminus ends are adapted for
32 longitudinal translation relative to each other to transmit
33 compressive force between said nail body and said leading end of
34 said lag screw assembly.

35

1 11. An intramedullary nail as claimed in claim 10 wherein said lag
2 screw body has an axial bore and said external threads include at
3 least one exit hole from said bore, a tang body disposed in said
4 bore having at least one tang adapted to extend through said at
5 least one exit hole to increase purchase in a bone.

6

7 12. An intramedullary nail as claimed in claim 9 wherein said
8 trailing end of said lag screw has a shaped exterior surface, said
9 shaped exterior surface preventing relative rotation of said lag
10 screw and said sleeve.

11

12 13. An intramedullary nail system kit for applying compressive
13 force across a fracture, said kit comprising an intramedullary nail
14 having a leading end, a trailing end, an axial bore, a transverse
15 clearance bore in said trailing end intersecting said axial bore,
16 and a plurality of portals through said leading end, a plurality of
17 anchors adapted to extend through said portals, a lag screw with
18 external screw threads on one end and internal screw threads on the
19 other end, a sleeve having a bore with an internal diameter larger
20 than said other end of said lag screw and an external diameter to
21 slidably extend through said transverse clearance bore, said sleeve
22 having at least one transverse slot exposing said bore, a sleeve
23 lock sized to slide in said axial bore at said trailing end, said
24 sleeve lock having at least one locking tab disposed in said axial
25 bore extending toward said transverse clearance bore, and a
26 compression screw with complimentary threads for the internal
27 threads of said lag screw, said compression screw having a shoulder
28 for engaging said sleeve, said kit including a subassembly with
29 said sleeve lock disposed at a first fixed position in said
30 trailing end of said axial bore of said intramedullary nail whereby
31 said kit is assembled by inserting said lag screw through said
32 transverse bore, inserting said sleeve over said lag screw through
33 said transverse bore and aligning said at least one slot with said
34 axial bore, sliding said sleeve lock of said subassembly to a
35 second fixed position in said axial bore engaging said at least one

1 locking tab with said at least one slot preventing longitudinal and
2 rotational movement between said sleeve and said nail, turning said
3 compression screw in said internal screw threads of said lag screw
4 so that said shoulder engages said sleeve providing longitudinal
5 translation between said sleeve and said lag screw producing
6 compressive force between said nail and said lag screw and
7 inserting said anchors through said portals.

8

9 14. An intramedullary nail system kit as claimed in claim 13
10 wherein said kit includes another subassembly with a cannulated
11 nail, said cannulated nail having a plurality of portals in said
12 leading end, a tang body disposed in said leading end of said
13 cannulated nail having a plurality of tangs adapted to extend
14 through said plurality of portals.

15

16 15. An intramedullary nail system kit as claimed in claim 14
17 wherein said kit includes a third subassembly with said lag screw
18 having a bore from said leading end to said trailing end, said
19 leading end of said lag screw having a plurality of exit holes from
20 said bore through said external screw threads, a tang body disposed
21 in said leading end of said bore having a plurality of tangs
22 adapted to extend through said exit holes whereby said kit is
23 assembled by manipulating said tang body to extend said tangs
24 through said exit holes.

25

26 16. An intramedullary nail system comprising an intramedullary
27 nail for implantation in a long bone, said intramedullary nail
28 having a leading end, a trailing end, and an axial bore
29 therethrough, a transverse clearance bore intersects said axial
30 bore in said trailing end, portals through said leading end from
31 said axial bore, a tang body movably disposed in said leading end
32 having tangs extending through said portals, a sleeve slidably
33 disposed in said transverse clearance bore, said sleeve having a
34 tubular side wall and a bore, a slot in said sidewall exposing said
35 bore, said bore of said sleeve having an internal surface, a

1 portion of said internal surface formed in a flat shape, a lag
2 screw slidably disposed in said sleeve, said lag screw having a
3 body and a leading end, external screw threads on said leading end,
4 internal screw threads in said body, said body having an external
5 surface formed in a flat shape, said flat shape of said internal
6 surface of said sleeve and said flat surface of said external
7 surface of said lag screw engaged to prevent relative
8 rotation between said sleeve and said lag screw, said slot in said
9 sleeve disposed in said axial bore of said nail, a sleeve lock
10 slidably fixed in said axial bore between said trailing end and
11 said clearance bore, said sleeve lock having a depending locking
12 tab extending in said axial bore toward said sleeve, said locking
13 tab engaging said slot preventing relative rotation and
14 longitudinal translation of said sleeve and said nail, an end cap
15 in said trailing end of said axial bore closing said bore and
16 engaging said sleeve lock, and a compression screw engaging said
17 internal threads in said lag screw body, said compression screw
18 having a shoulder engaging said sleeve providing relative
19 longitudinal translation between said lag screw and said sleeve.

20

21

22

23

24

25

26

27

28

29

30

31

32

33

34

35

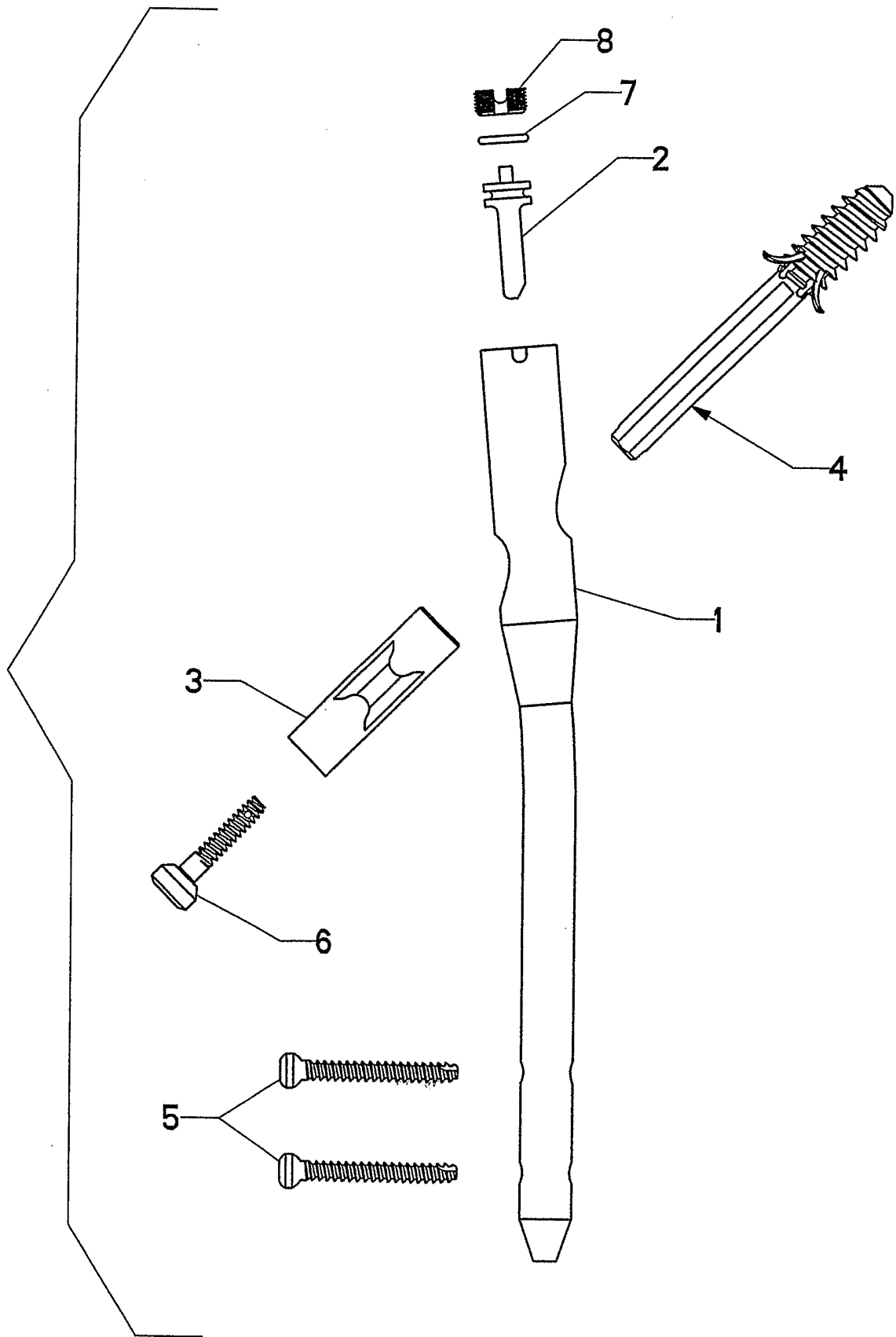

FIG. 1

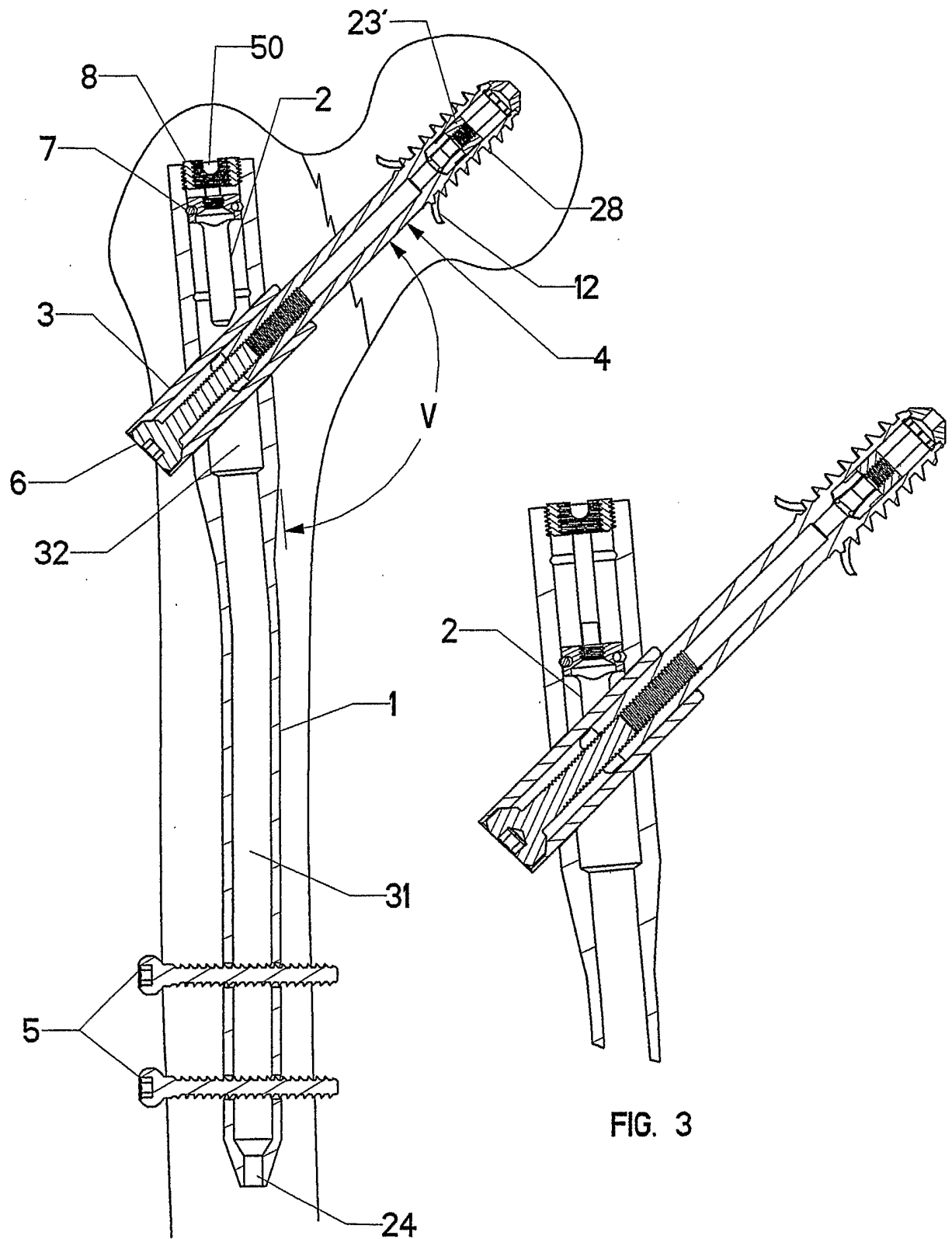

FIG. 2

FIG. 3

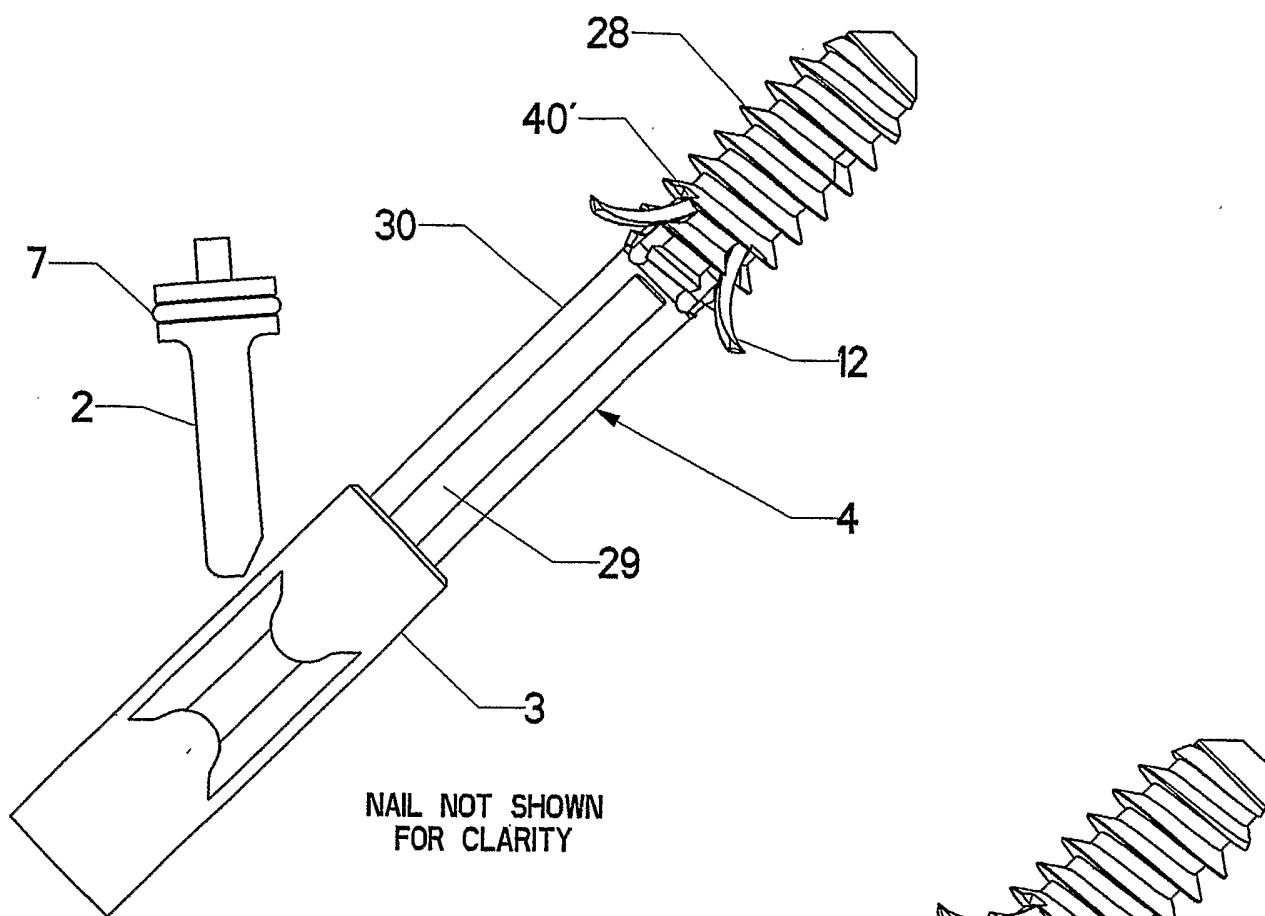

FIG. 4

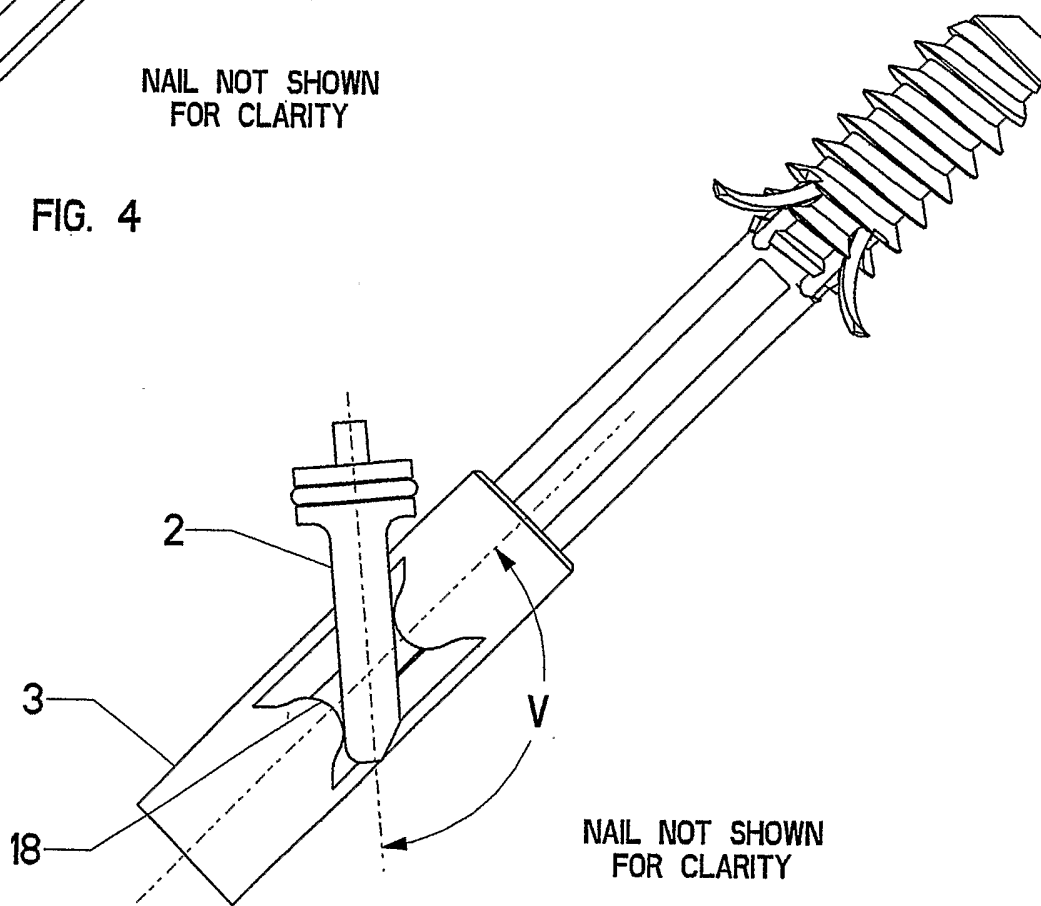
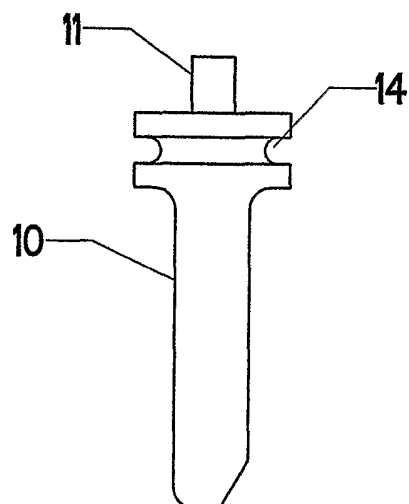
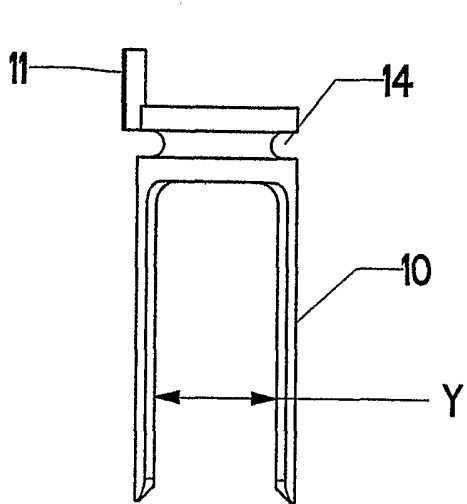
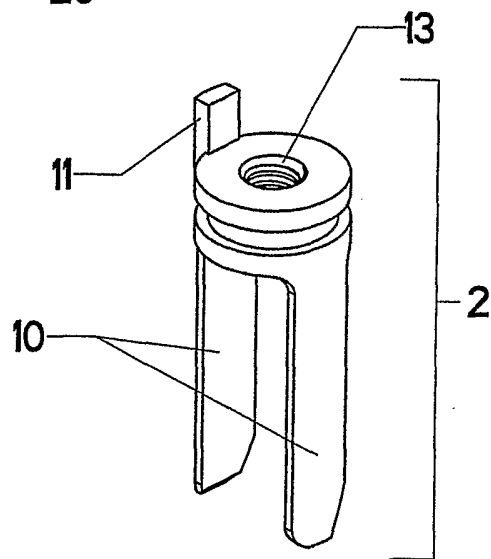
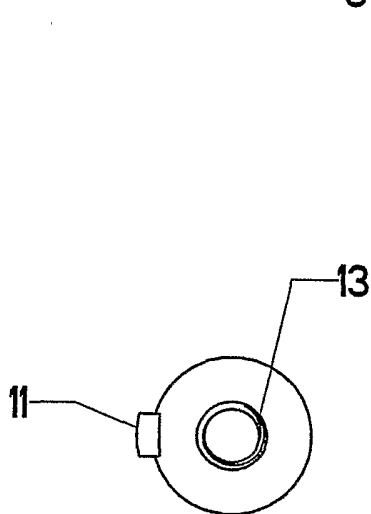
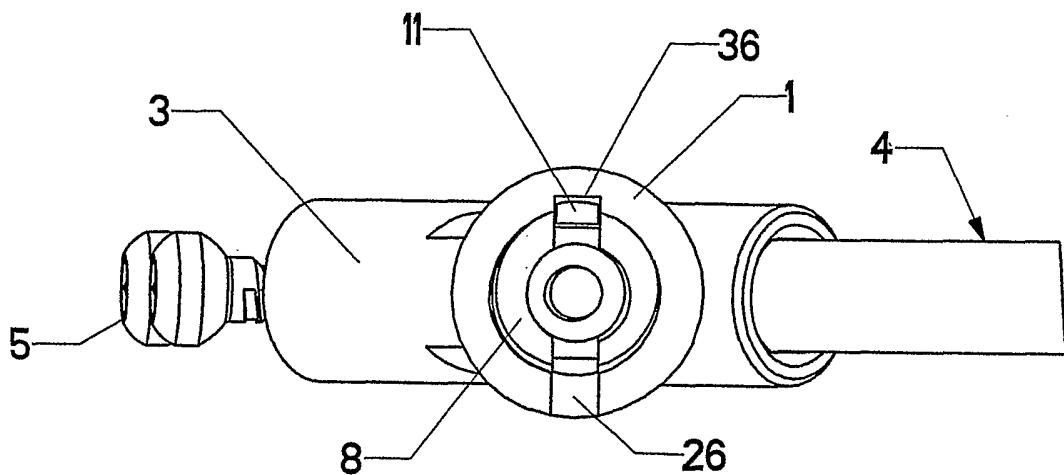

FIG. 5



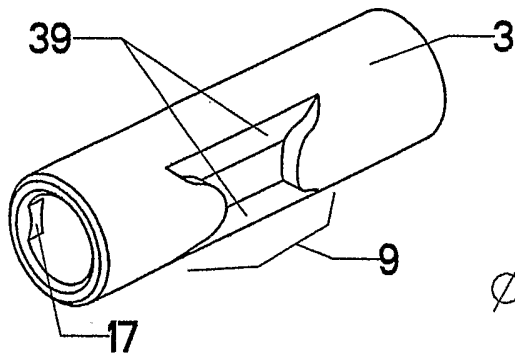

FIG. 11

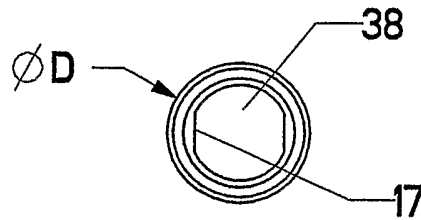

FIG. 12

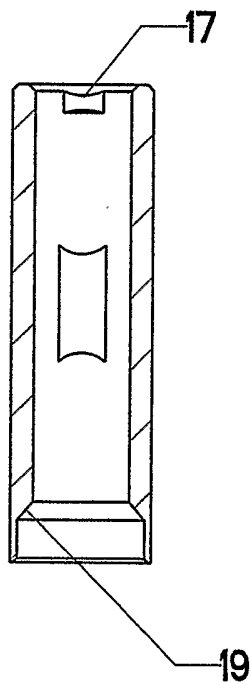

FIG. 13

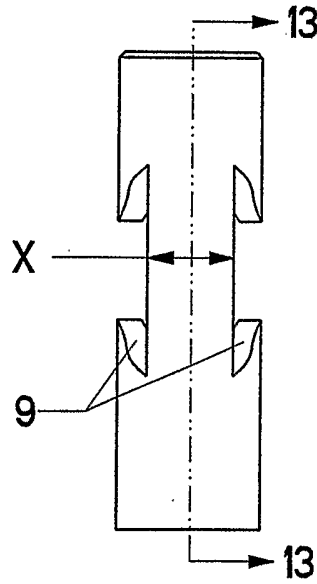

FIG. 14

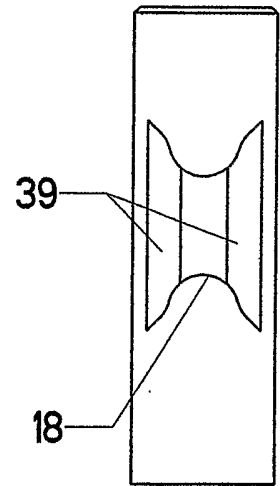

FIG. 15

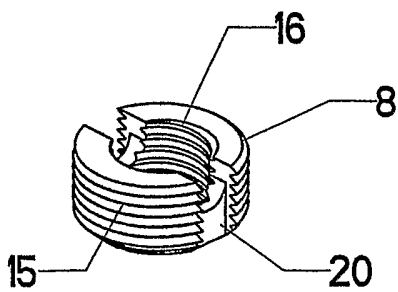

FIG. 16

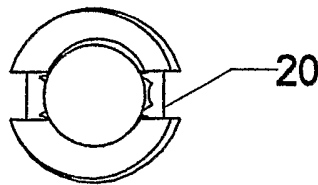

FIG. 17

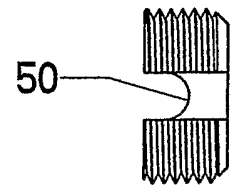

FIG. 18

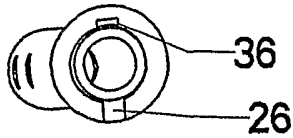

FIG. 19

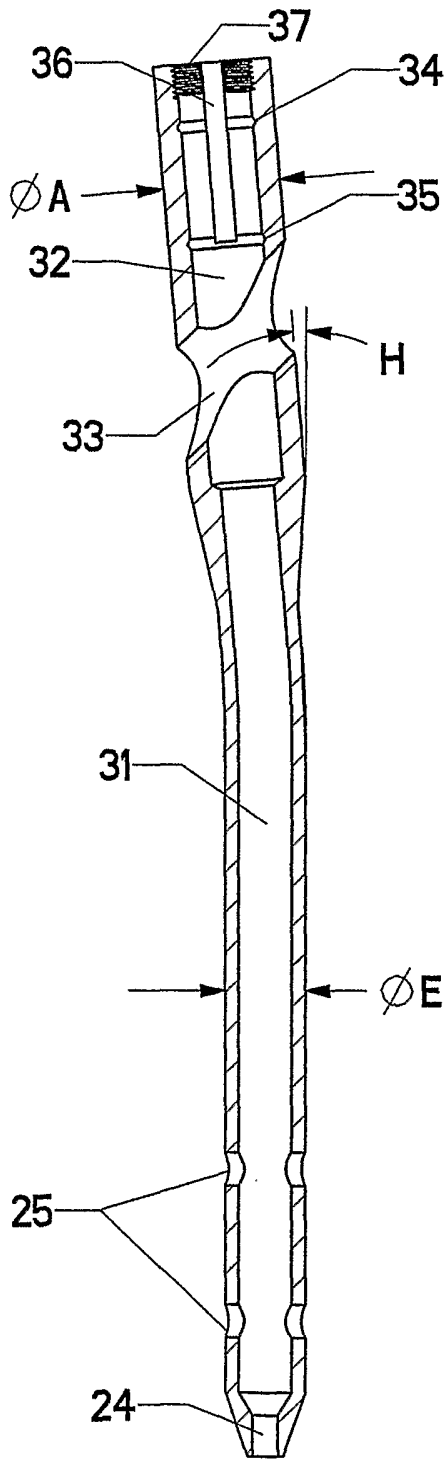

FIG. 20

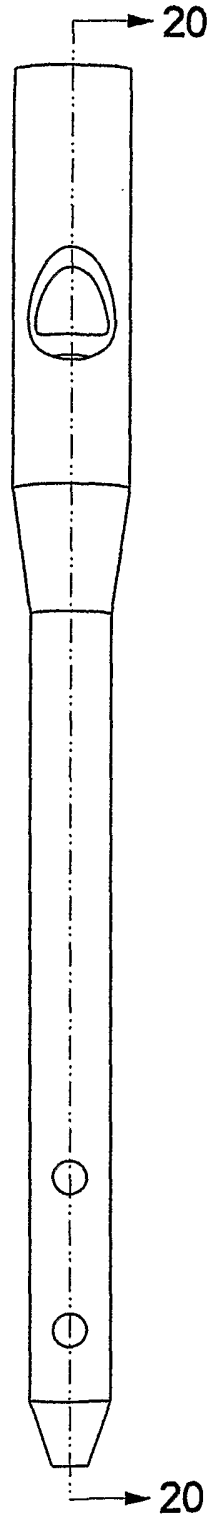

FIG. 21

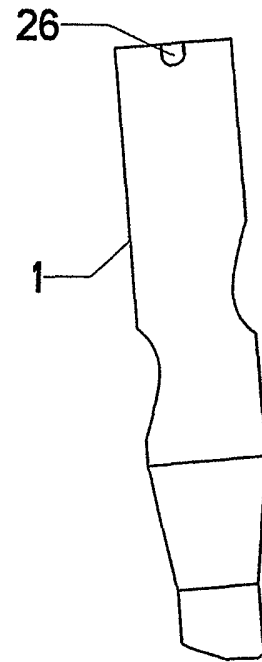

FIG. 22

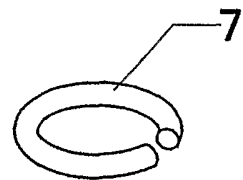

FIG. 23

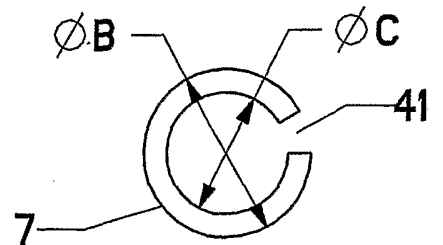

FIG. 24

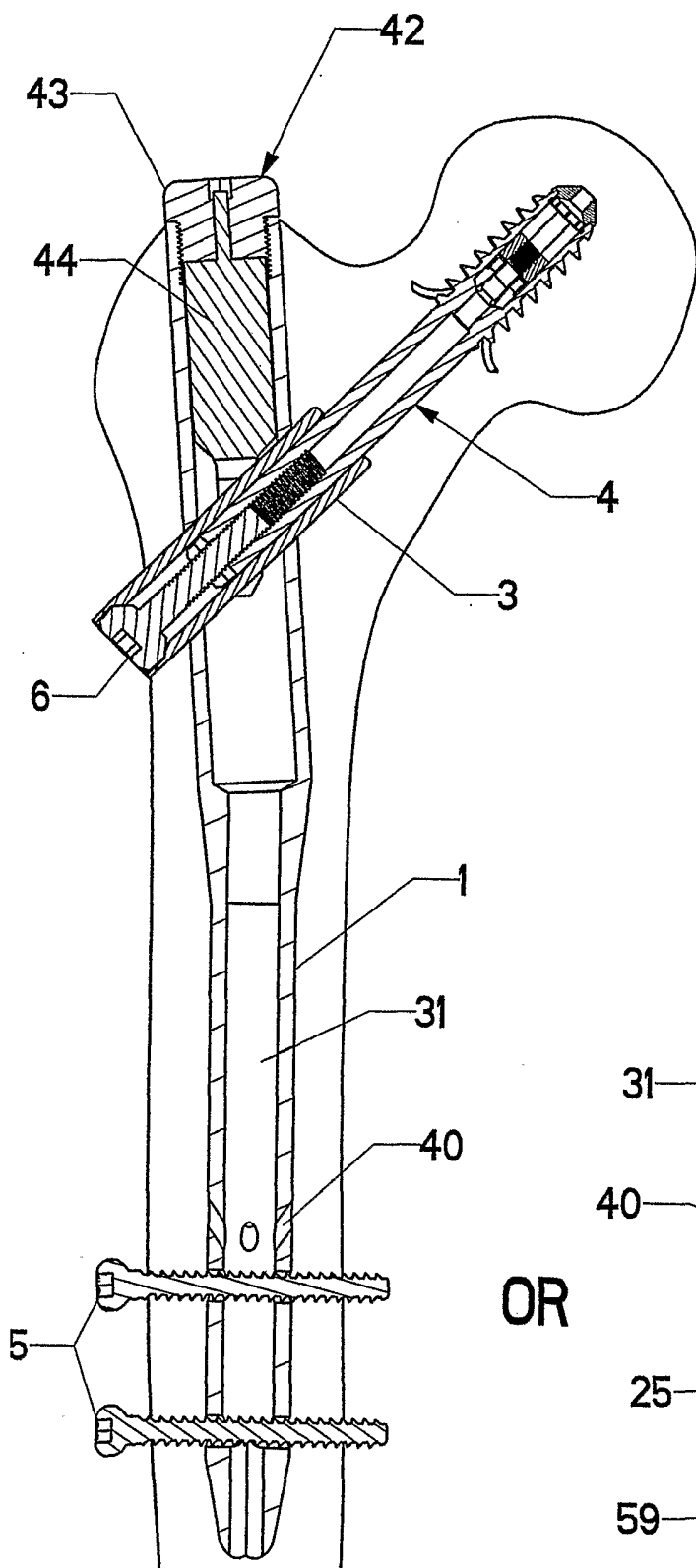

FIG. 25

OR

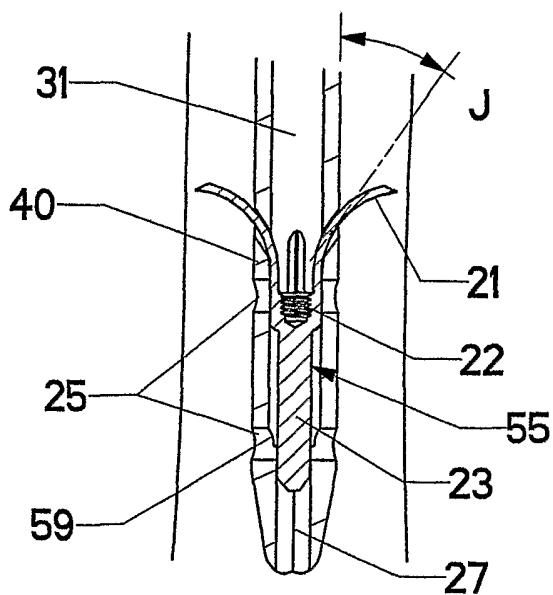

FIG. 25A

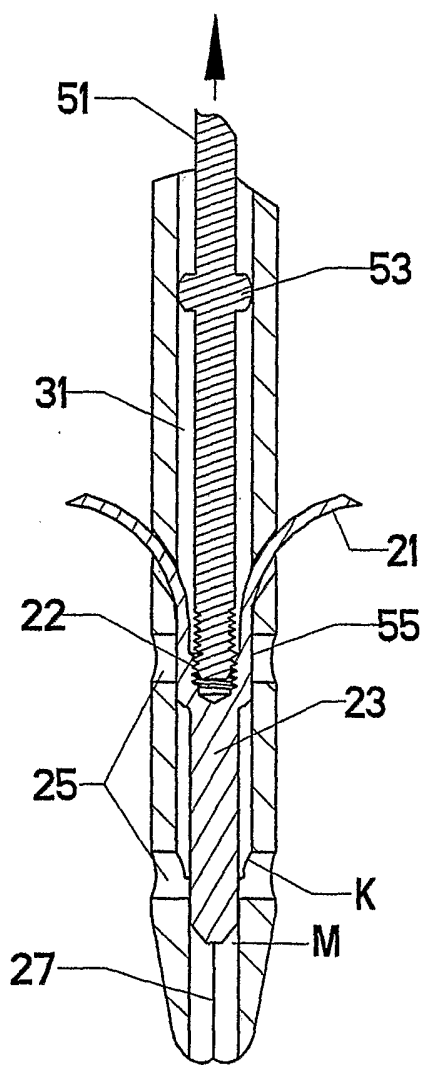

FIG. 26

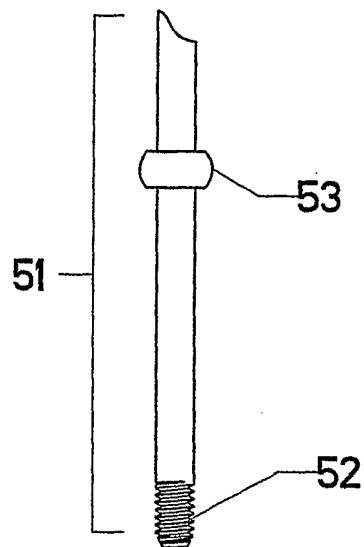

FIG. 27

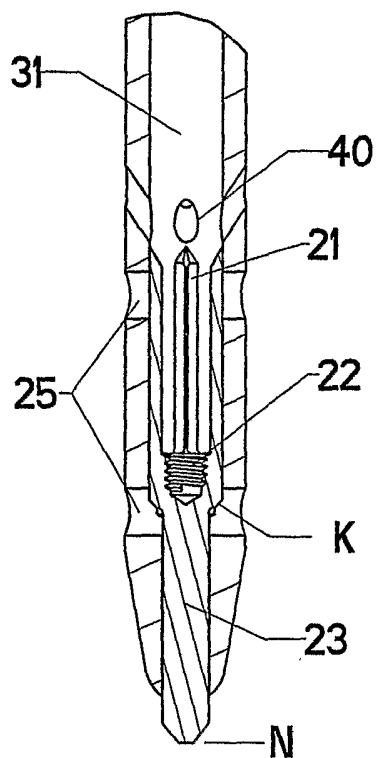
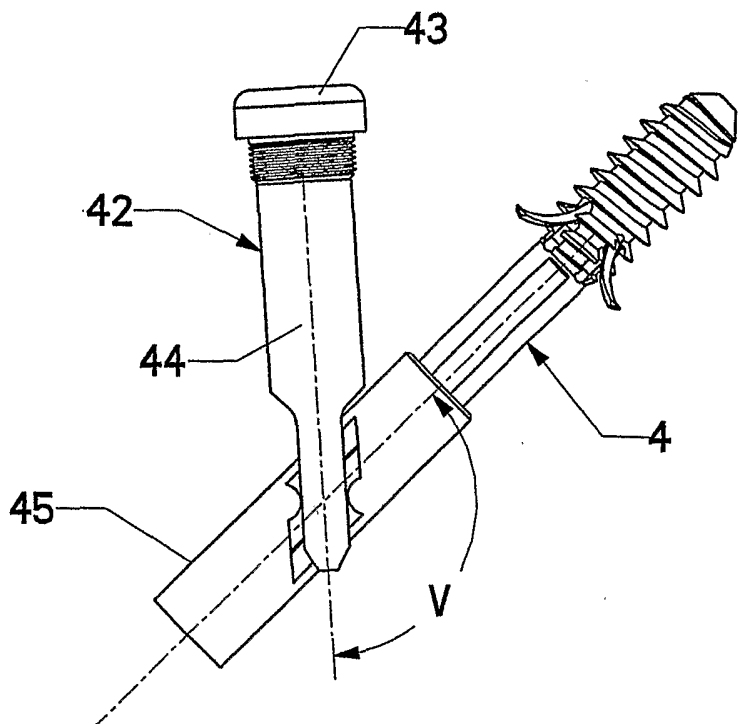

FIG. 28



NAIL NOT SHOWN
FOR CLARITY

FIG. 29

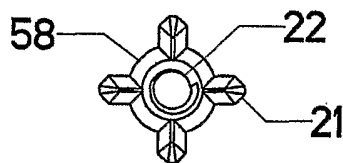

FIG. 30

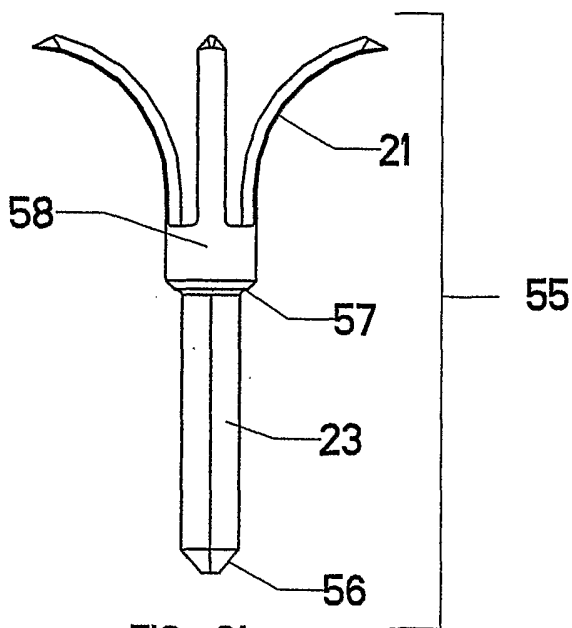

FIG. 31

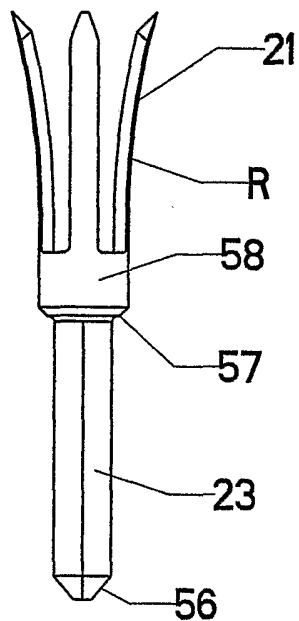

FIG. 32

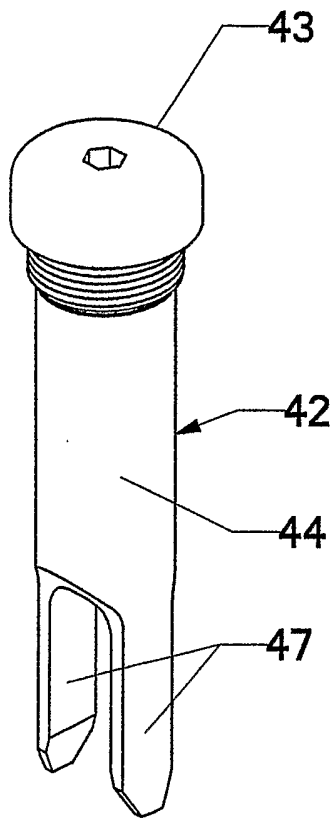

FIG. 33

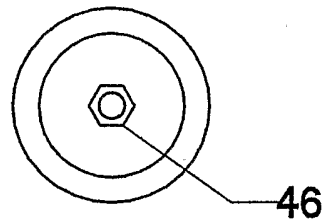

FIG. 34

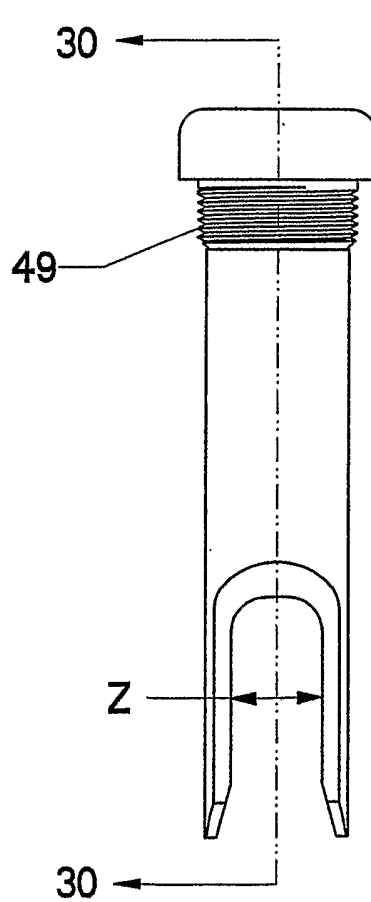

FIG. 35

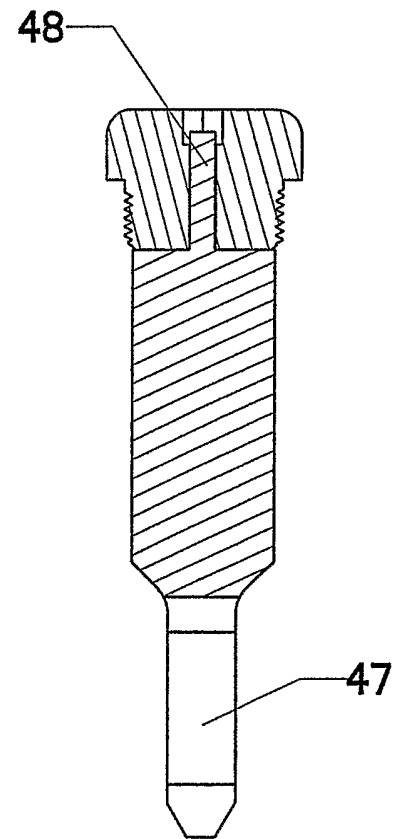

FIG. 36