



(12) Patent specification

(10) SE 539 758 C2

(21) Patent application number:	1451477-2	(51) Int.Cl.:	
(45) Grant of patent:	2017-11-21	F23D 14/62	(2006.01)
(41) Available to the public:	2016-06-05	F23C 13/00	(2006.01)
(22) Filing date:	2014-12-04	<i>H01M 8/04</i>	(2016.01)
(24) Effective date:	2014-12-04	<i>H01M 8/06</i>	(2016.01)
(30) Priority data:	---		

- (73) Patentee: Powercell Sweden AB, Ruskvädersgatan 12, 418 34 Göteborg SE
 (72) Inventor: Per Ekdunge, Västra Frölunda SE
 Ida Toffefors, Göteborg SE
 Federico Ghirelli, Göteborg SE
 (74) Agent: Ruth Seifert, Fasanenweg 1, 82061, Neuried DE
 (54) Title: Catalytic burner arrangement
 (56) Cited documents: WO 2014035329 A1
 (57) Abstract:

Disclosed is a catalytic burner arrangement (110) comprising at least a catalytic burner unit (10) with a housing (12) having a reaction chamber (13) in which a catalyst (14) is arranged, wherein the catalyst (14) is adapted to react a fuel, particularly a hydrogen containing fluid, with an oxidant, particularly air, for producing heat, said housing (12) having a fluid inlet (16) for supplying a fluid stream into the housing (12) and a fluid outlet (18) for exiting a fluid stream from the housing (12), and said catalytic burner arrangement (110) further comprises a mixing unit (20) forming a mixing chamber (26) in which fuel and oxidant are mixed, wherein said mixing unit (20) comprises a fuel inlet (22), an oxidant inlet (24) and a fuel-oxidant-mixture outlet, and wherein the fluid inlet (16) of the catalytic burner unit (10) merges with the fuel-oxidant-outlet (28) of the mixing unit (20) for transferring the fuel-oxidant-mixture from the mixing chamber (26) to the reaction chamber (13) of the catalytic burner unit (10), **characterized in that** said fuel-oxidant-outlet of the mixing chamber (26) is pipe-shaped and extends into the mixing chamber (26) of the mixing unit (20), wherein a length (L) of the pipe-shaped fuel-oxidant-outlet extends over the oxidant inlet (24) and/or the fuel inlet (22).as well as an auxiliary power assembly (100) using the heat of such a catalytic burner arrangement (110) for the production of steam.

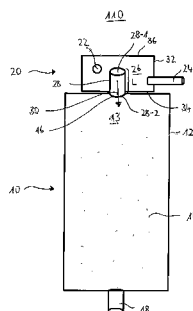

113

PC1402 SE

Fig. 1.

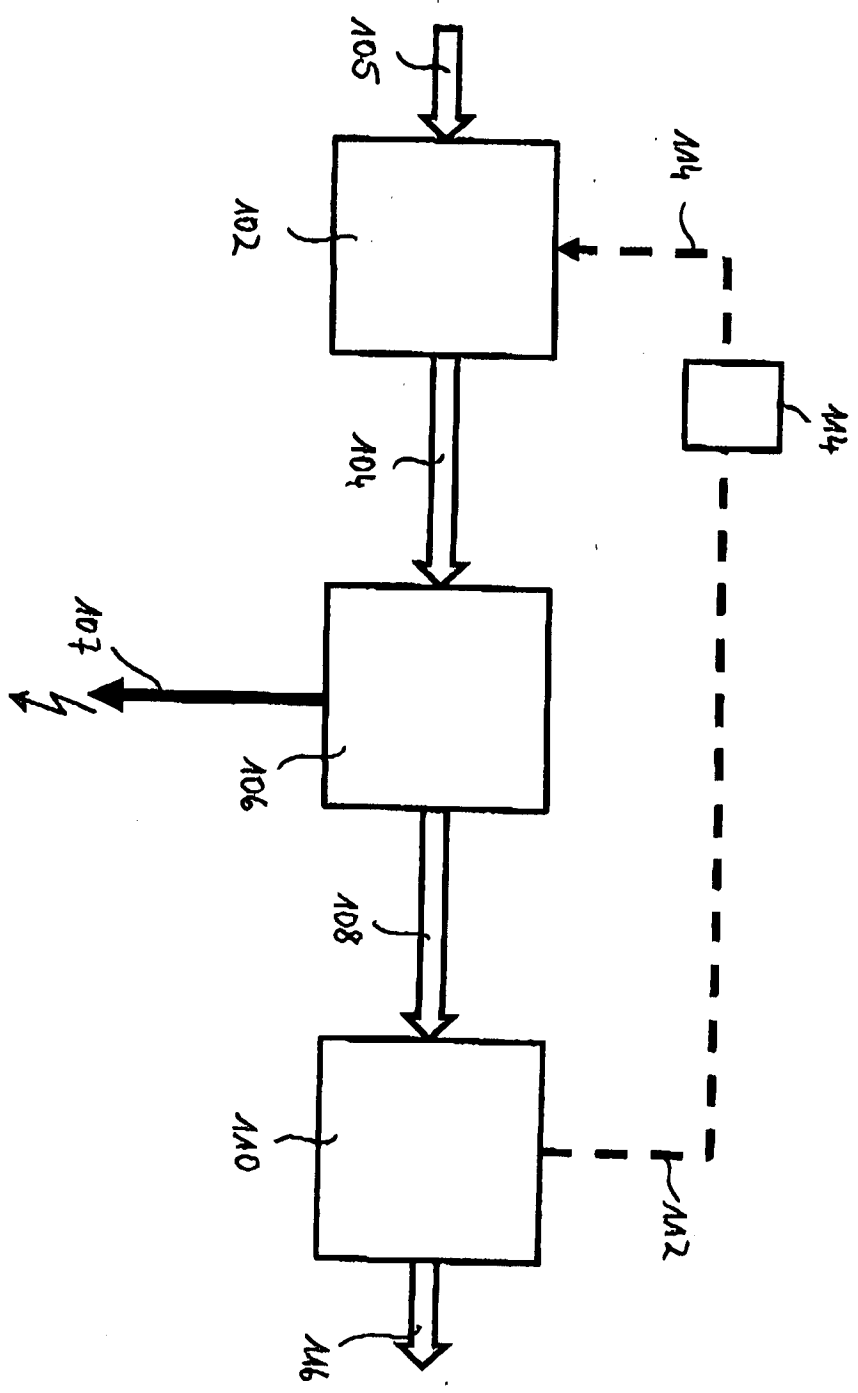

100

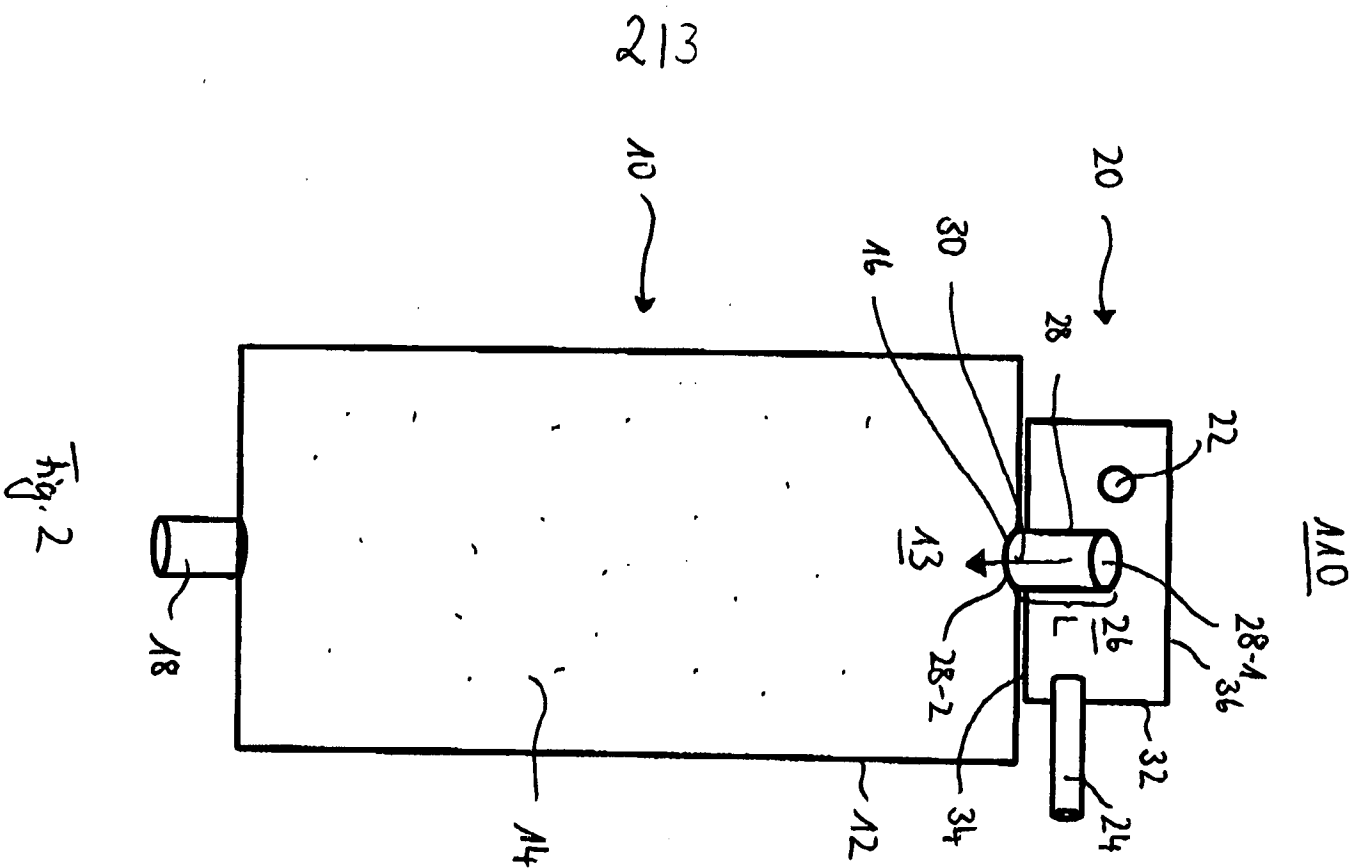

Fig. 2

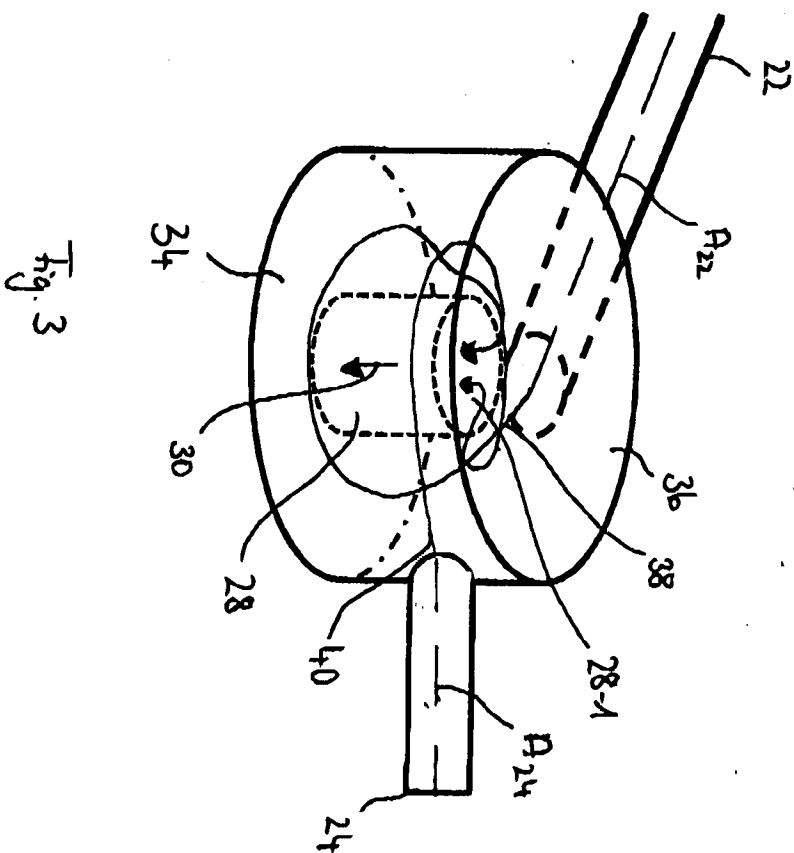

Fig. 3

3/3

fig. 6

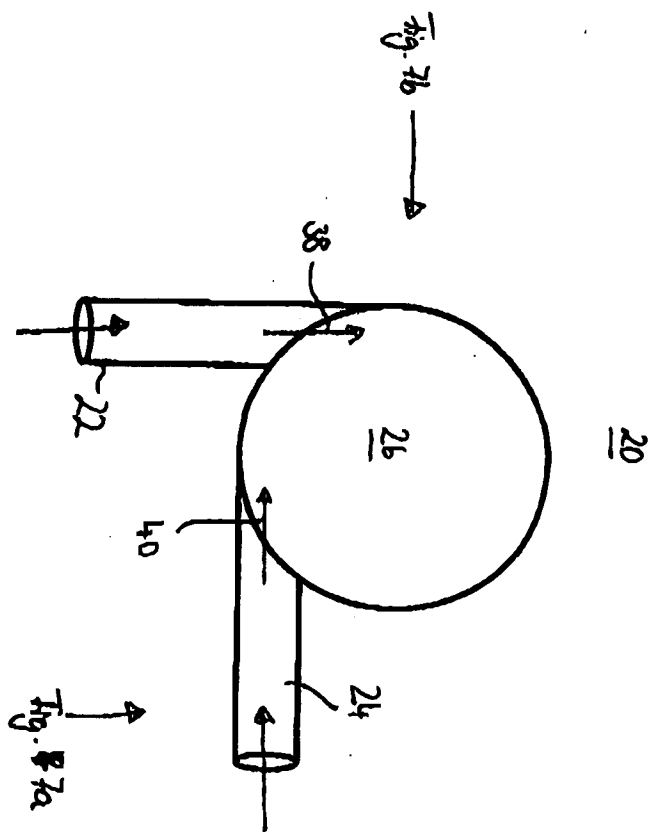

fig. 7a

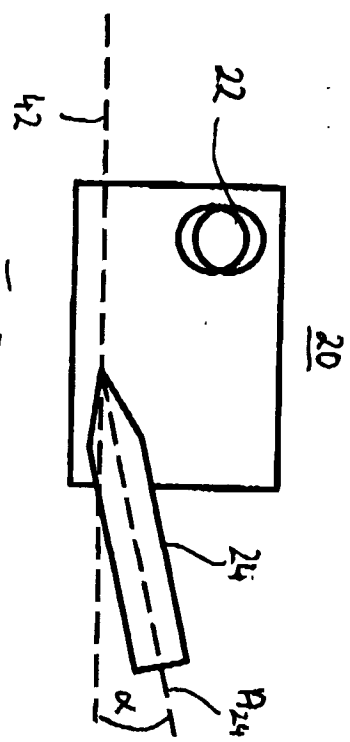

fig. 7b

