



(19) **United States**
(12) **Patent Application Publication**
Recker et al.

(10) **Pub. No.: US 2012/0098432 A1**
(43) **Pub. Date: Apr. 26, 2012**

(54) **WIRELESS POWER INVERTER FOR LIGHTING**

(75) Inventors: **Michael V. Recker**, Gaithersburg, MD (US); **David B. Levine**, Pepper Pike, OH (US)

(73) Assignee: **WIRELESS ENVIRONMENT, LLC.**, Elyria, OH (US)

(21) Appl. No.: **13/335,014**

(22) Filed: **Dec. 22, 2011**

is a continuation-in-part of application No. 11/847,509, filed on Aug. 30, 2007, which is a continuation-in-part of application No. 11/692,075, filed on Mar. 27, 2007.

Publication Classification

(51) **Int. Cl.**
H05B 37/00 (2006.01)
H02J 7/02 (2006.01)
(52) **U.S. Cl.** **315/86; 307/66**

Related U.S. Application Data

(63) Continuation of application No. 13/247,620, filed on Sep. 28, 2011, which is a continuation of application No. 13/231,822, filed on Sep. 13, 2011, which is a continuation-in-part of application No. 12/626,640, filed on Nov. 26, 2009, now Pat. No. 8,033,686, which

(57) **ABSTRACT**

In embodiments of the present invention improved capabilities are described for systems and methods that employ a control component and/or power source integrated in an LED based light source to control and/or power the LED light source wirelessly. In embodiments, the LED based light source may take the form of a standard light bulb that plugs into a standard lighting socket or fixture.

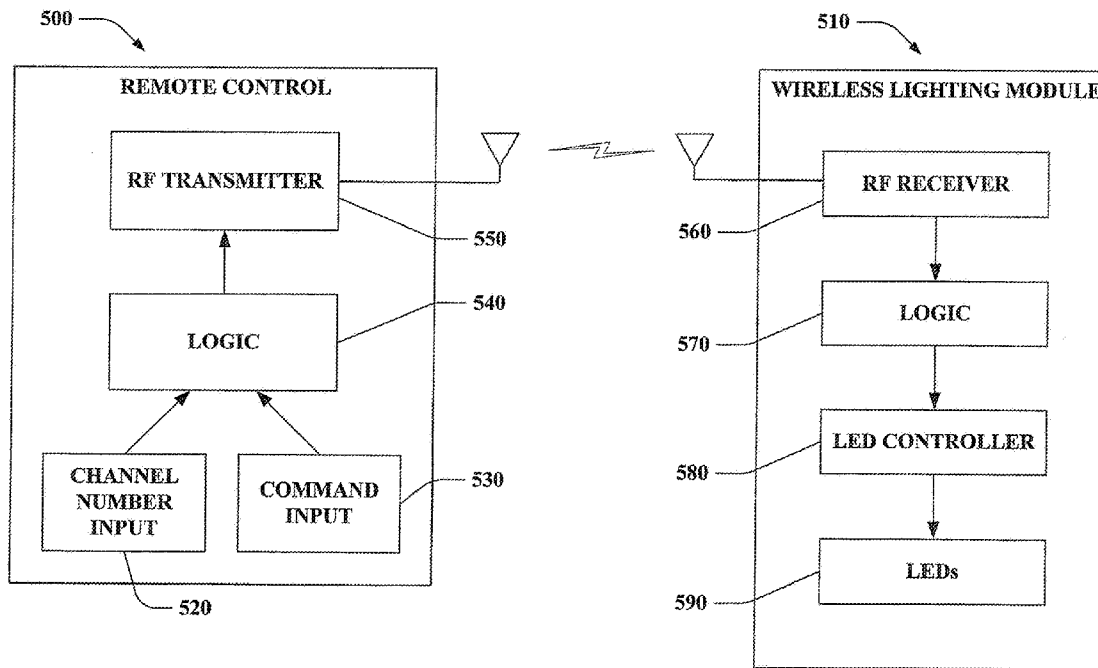

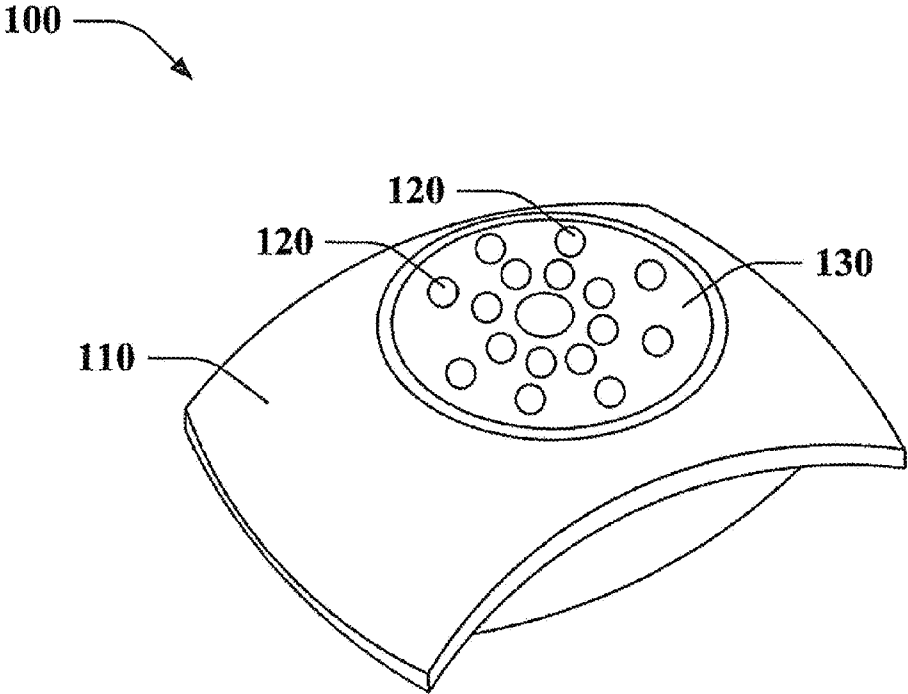

FIG. 1

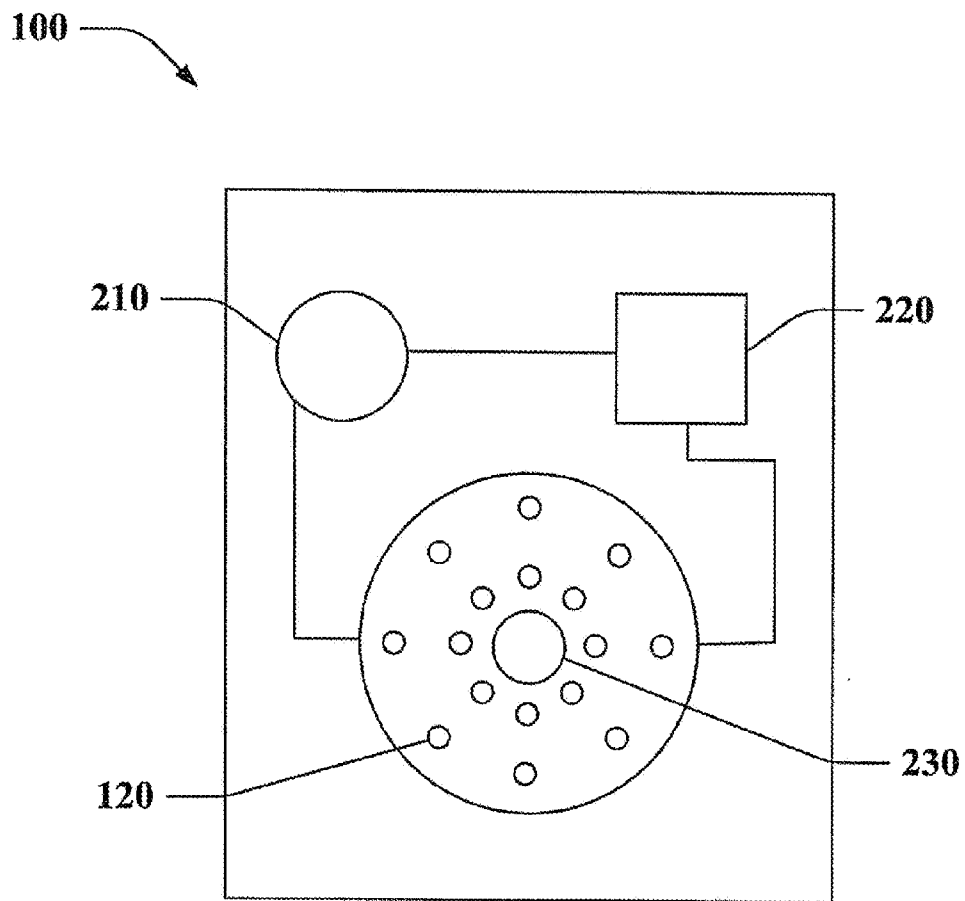

FIG. 2

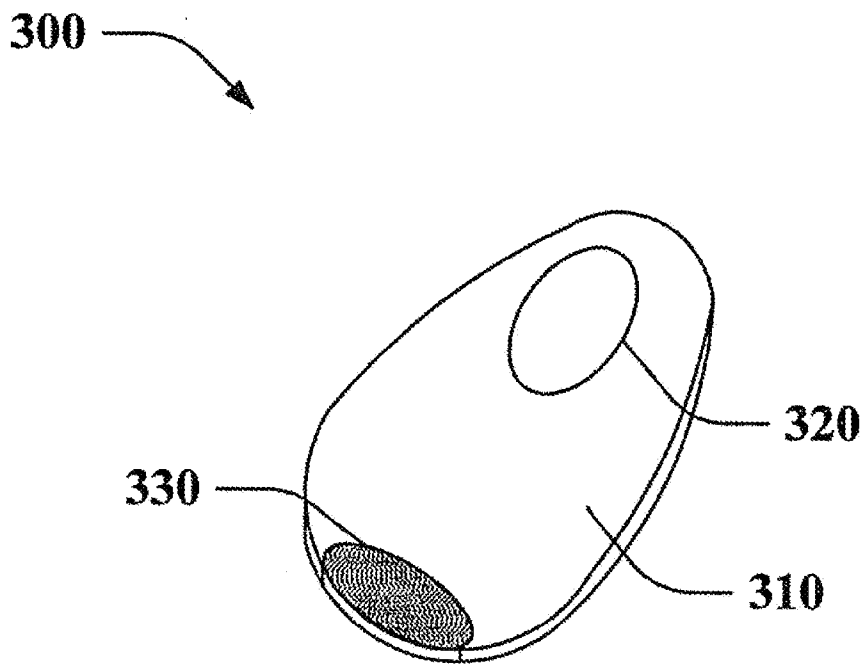

FIG. 3

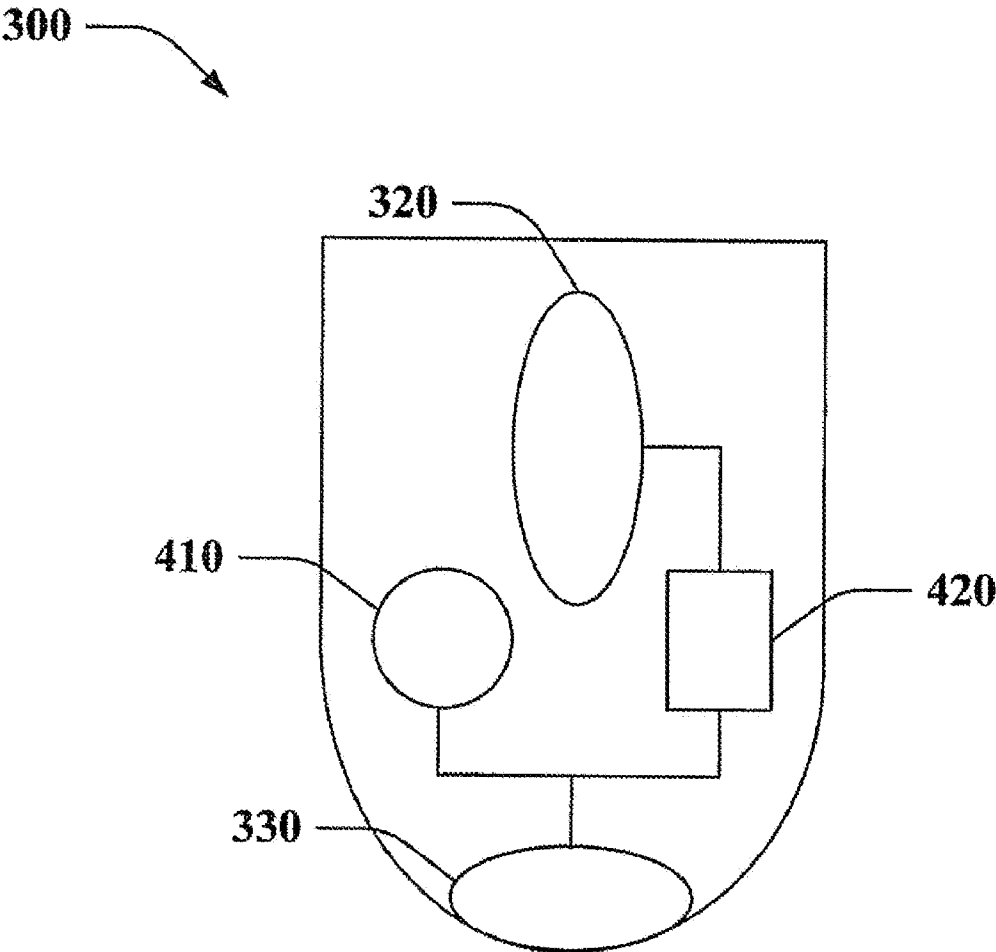

FIG. 4

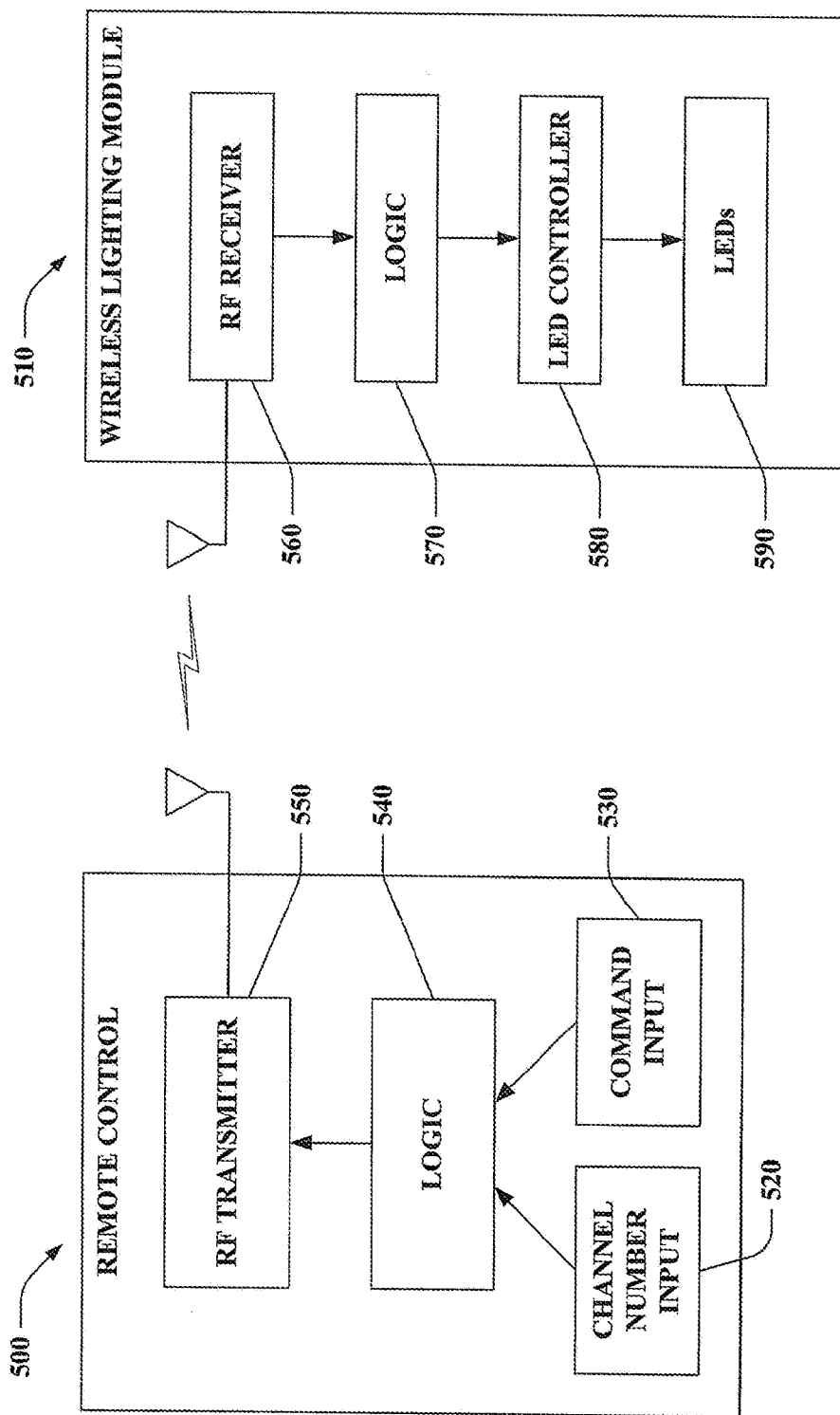

FIG. 5

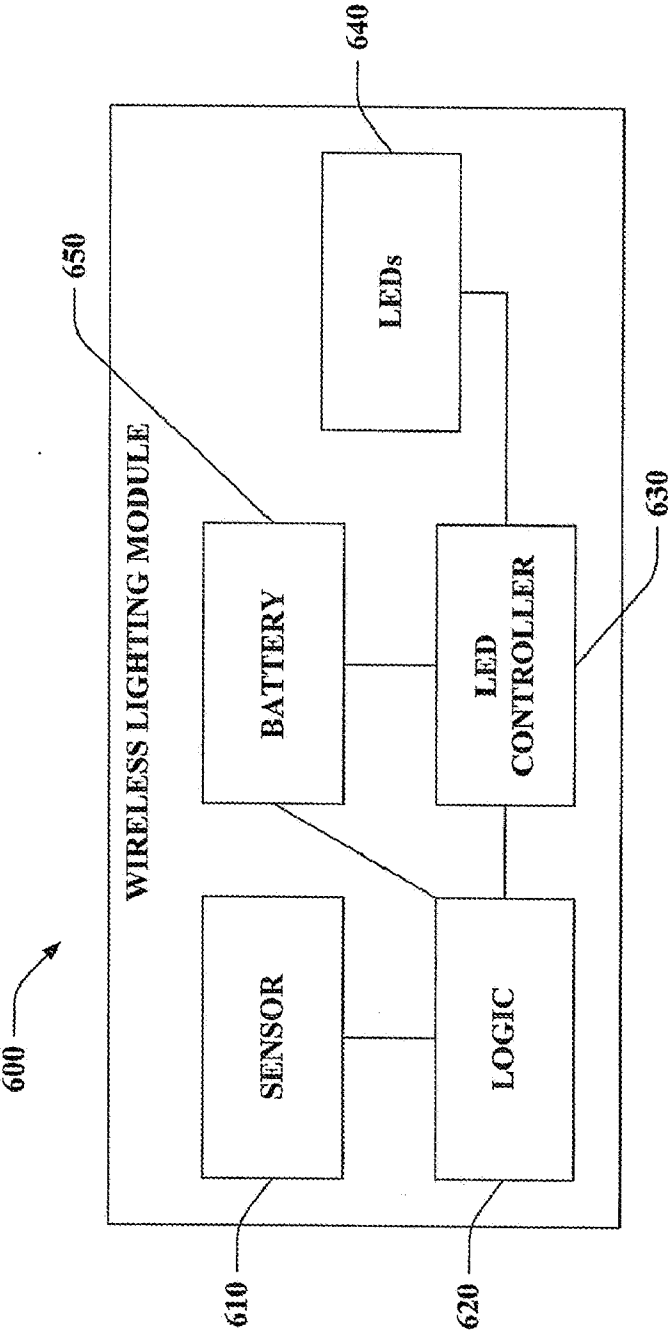

FIG. 6

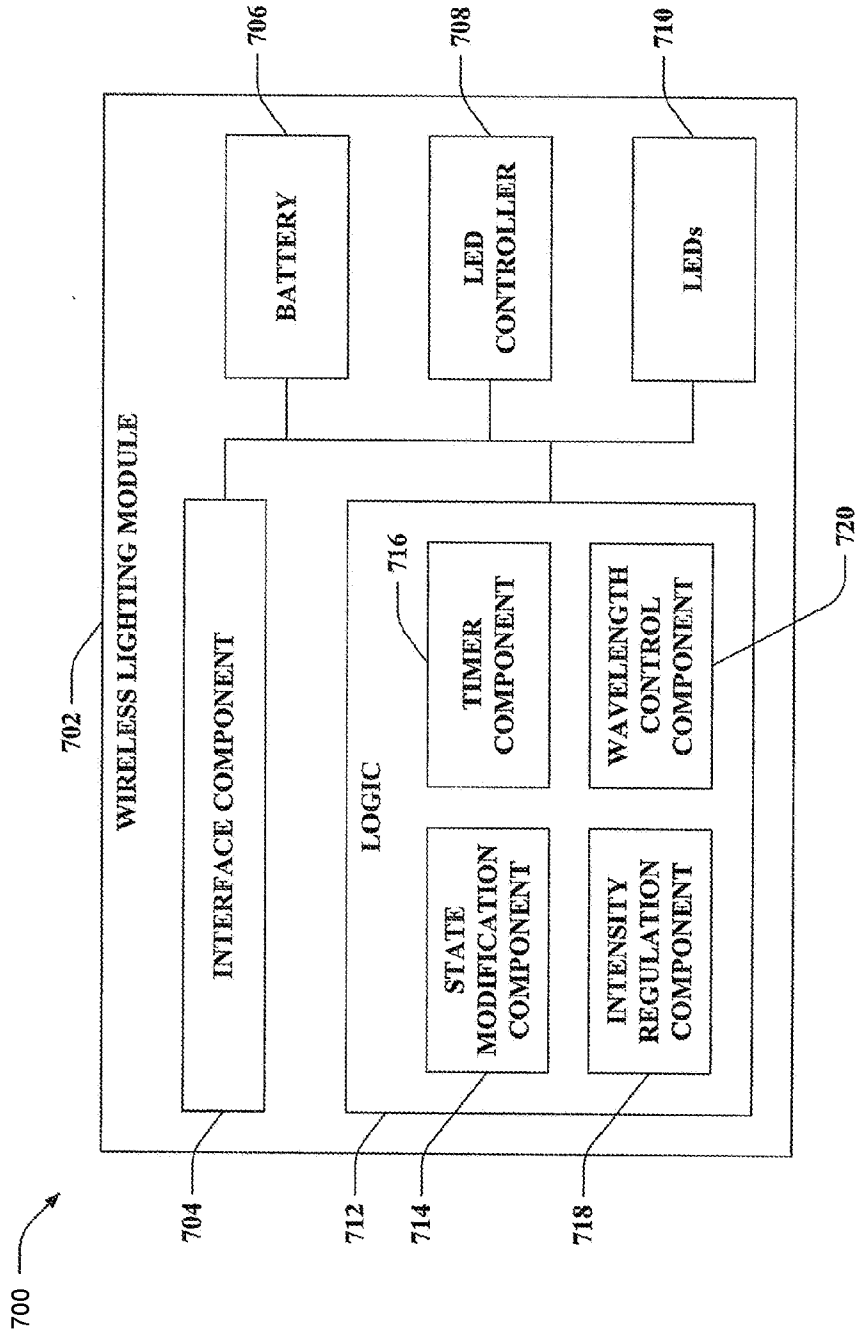

FIG. 7

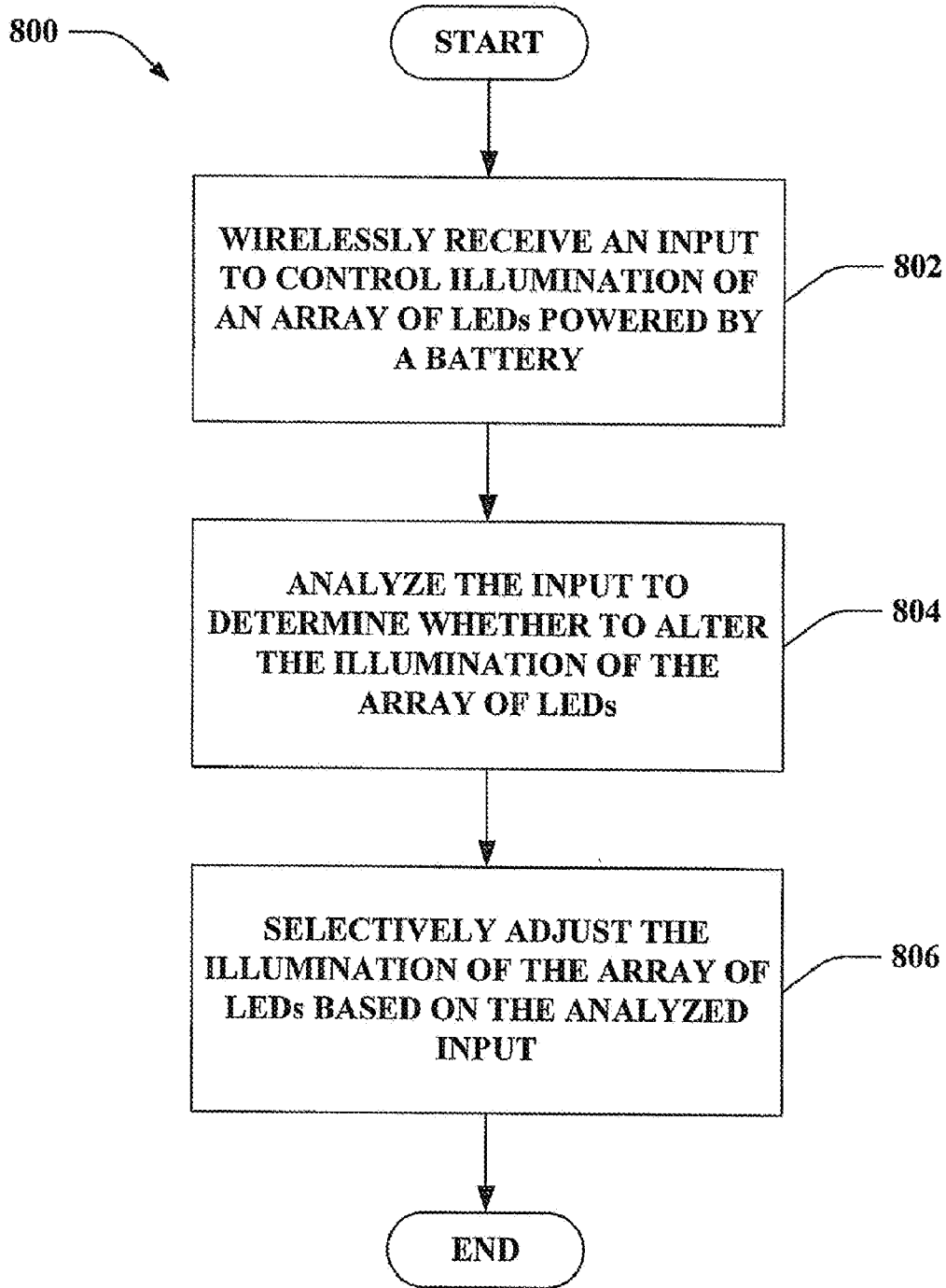

FIG. 8

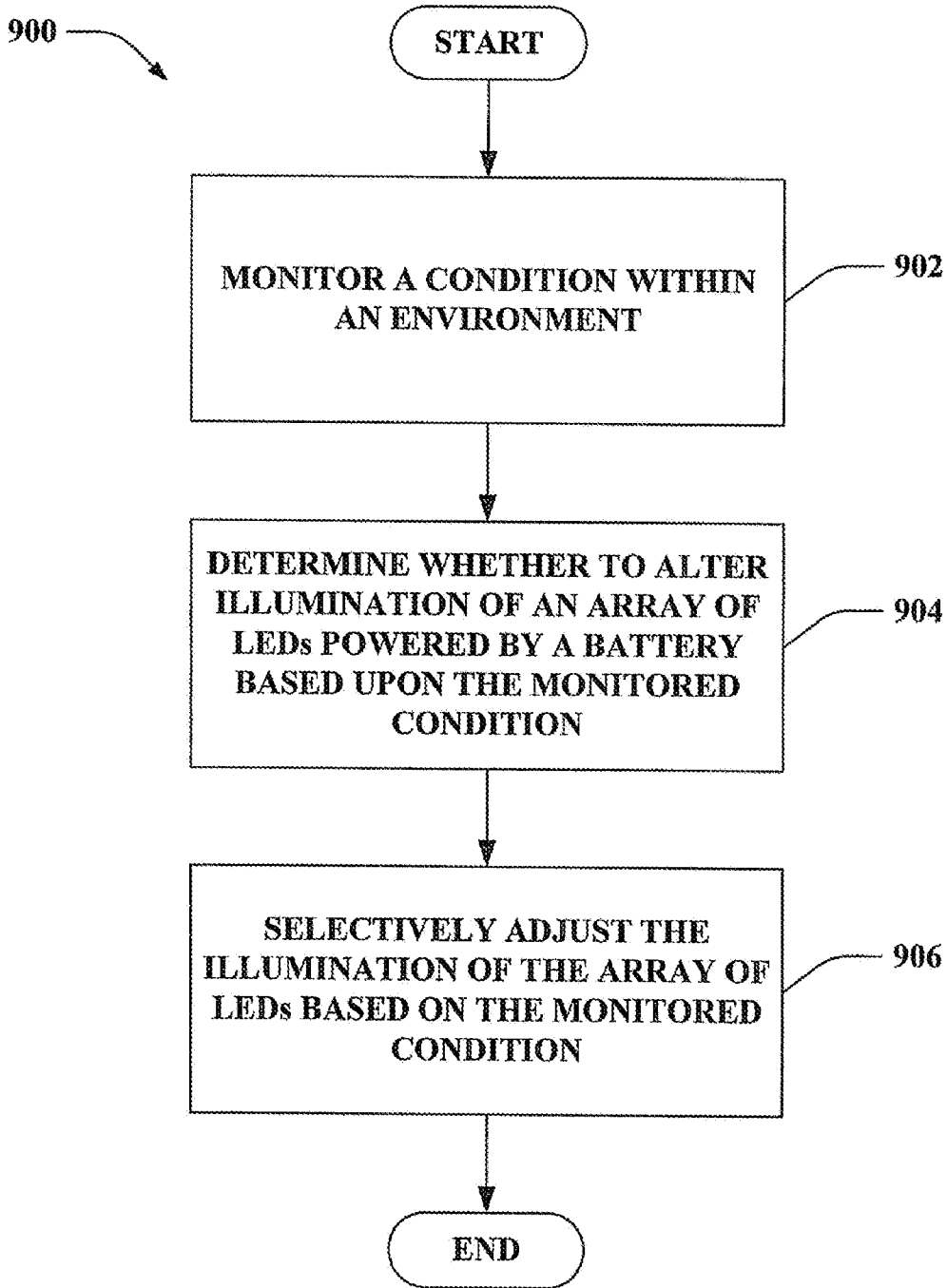

FIG. 9

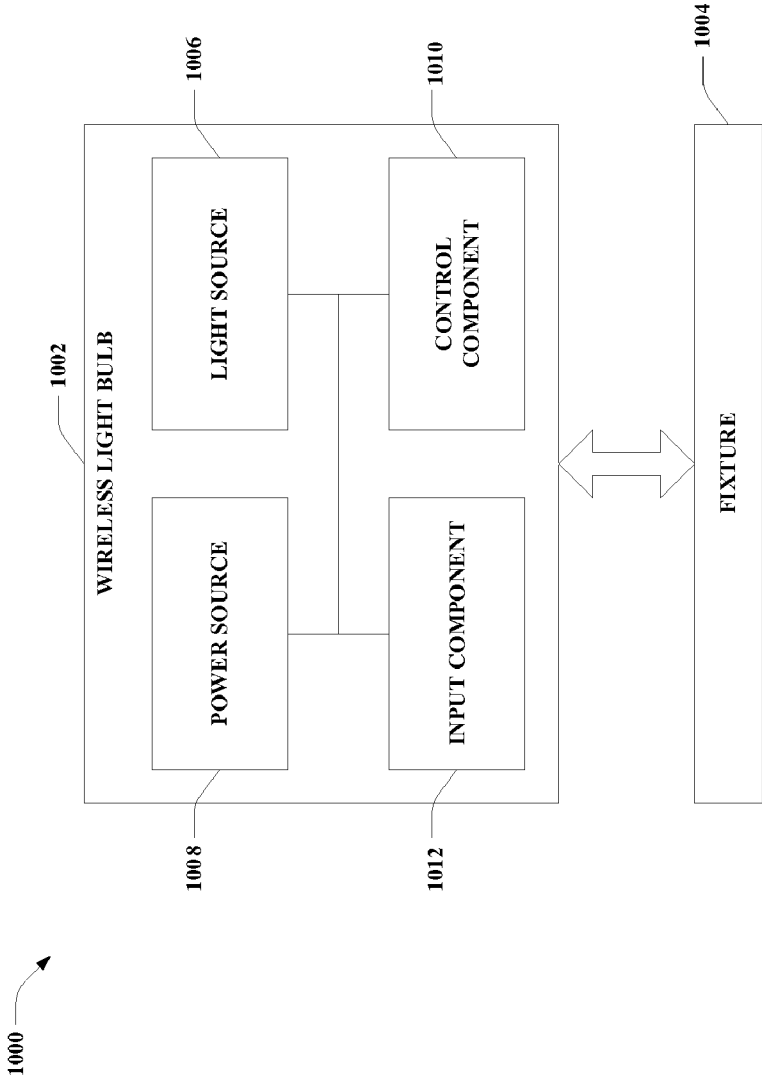

FIG. 10

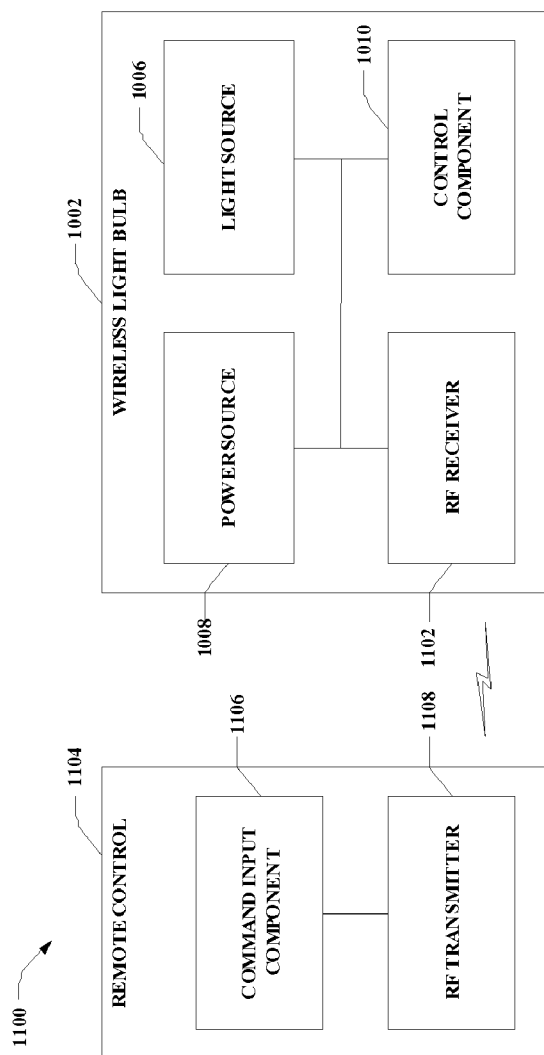

FIG. 11

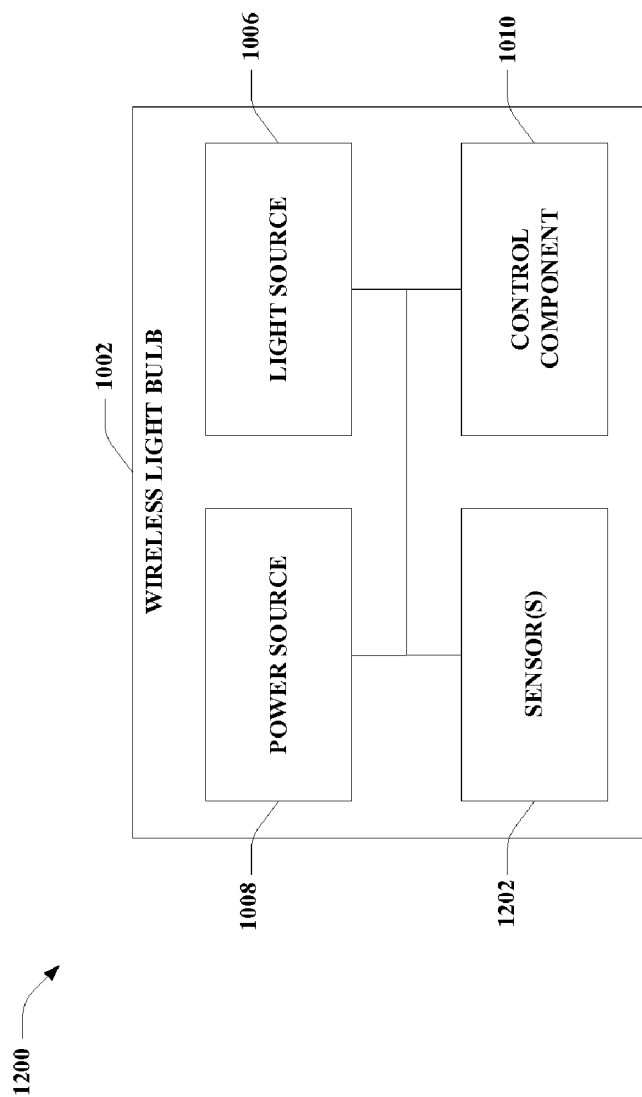

FIG. 12

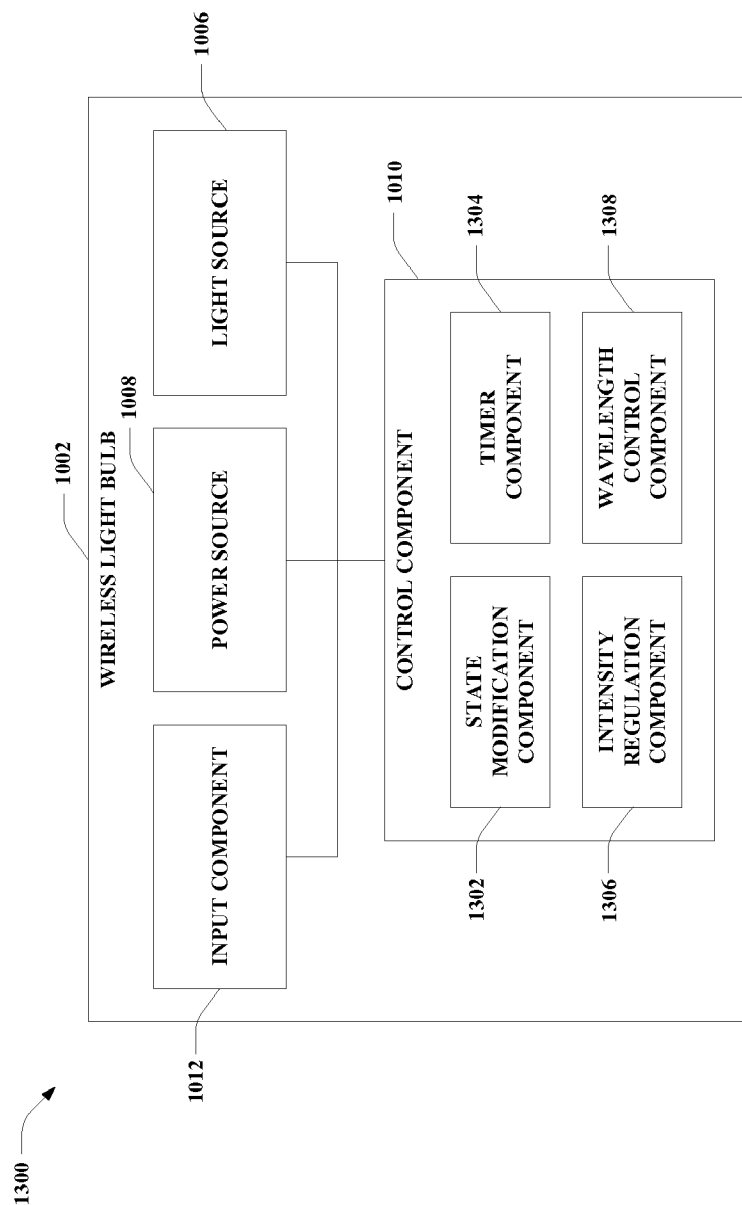

FIG. 13

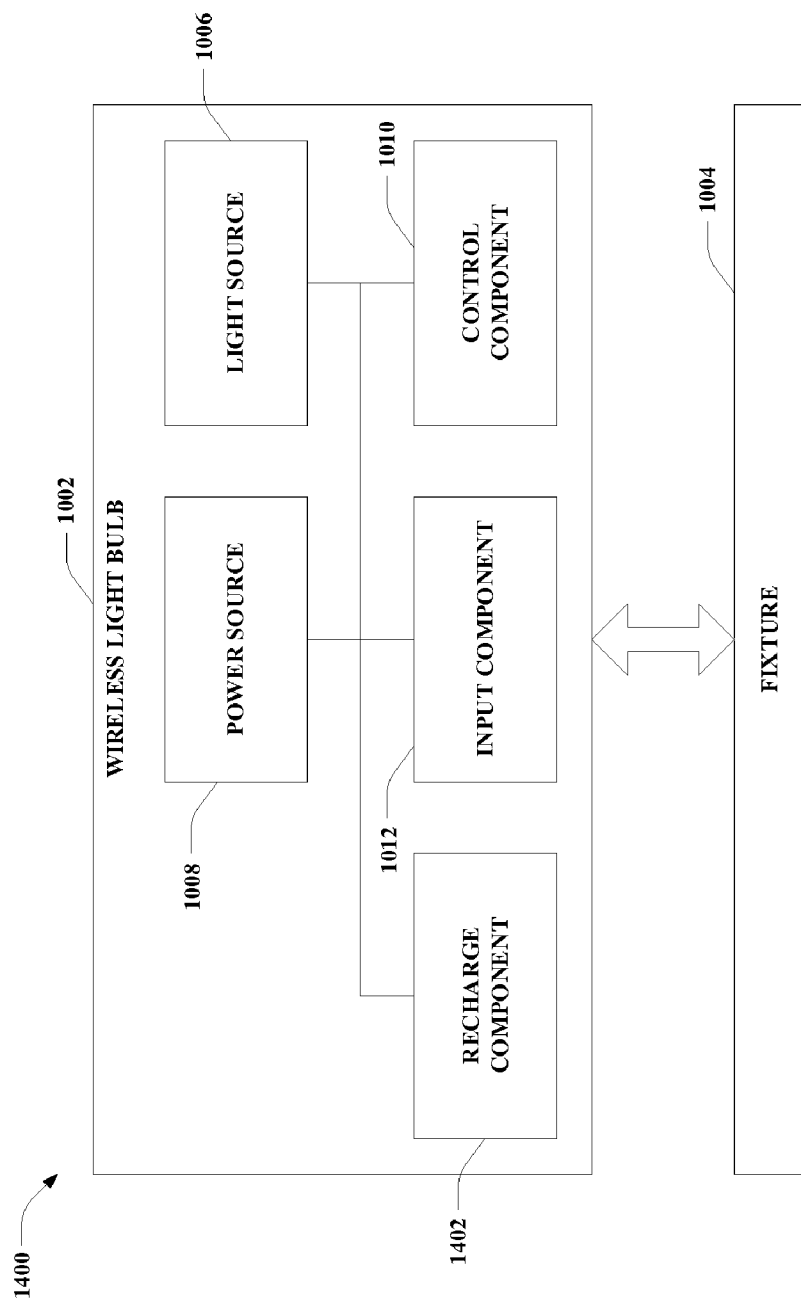

FIG. 14

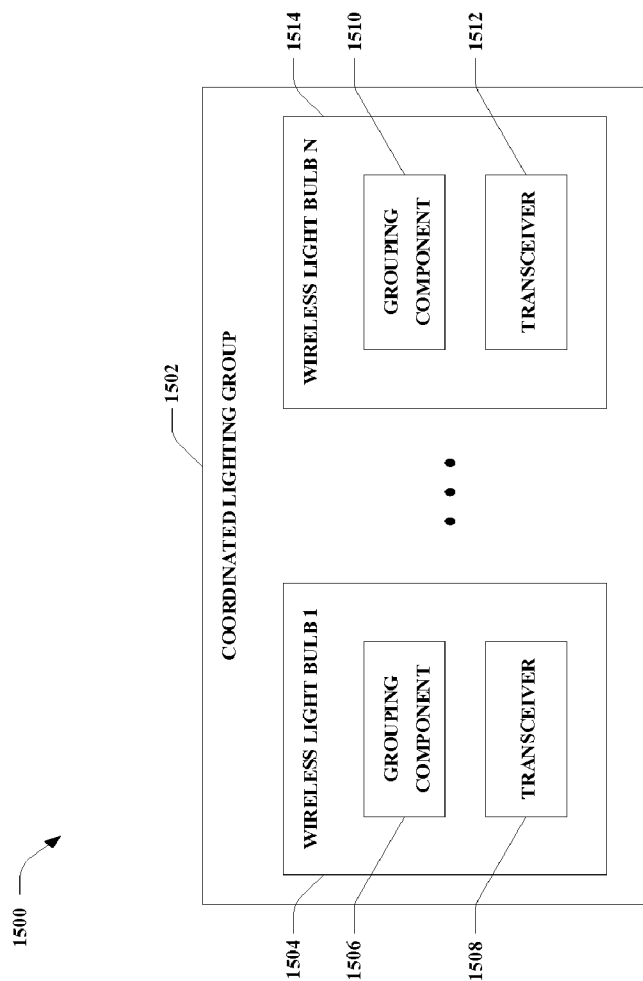

FIG. 15

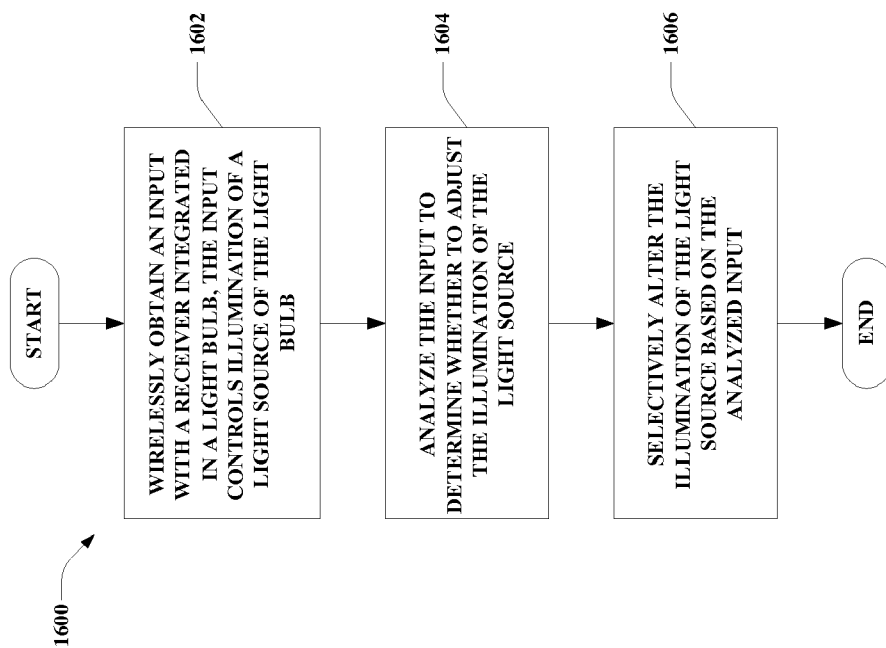

FIG. 16

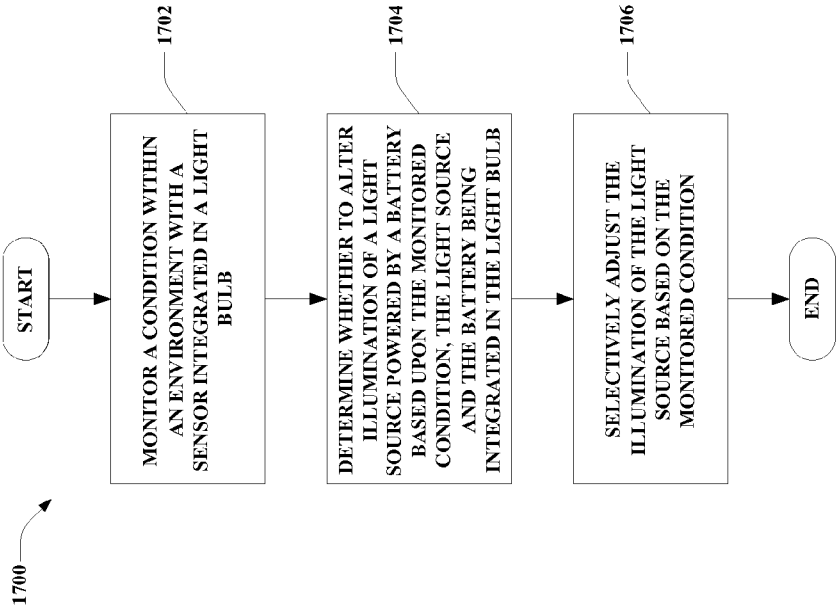

FIG. 17

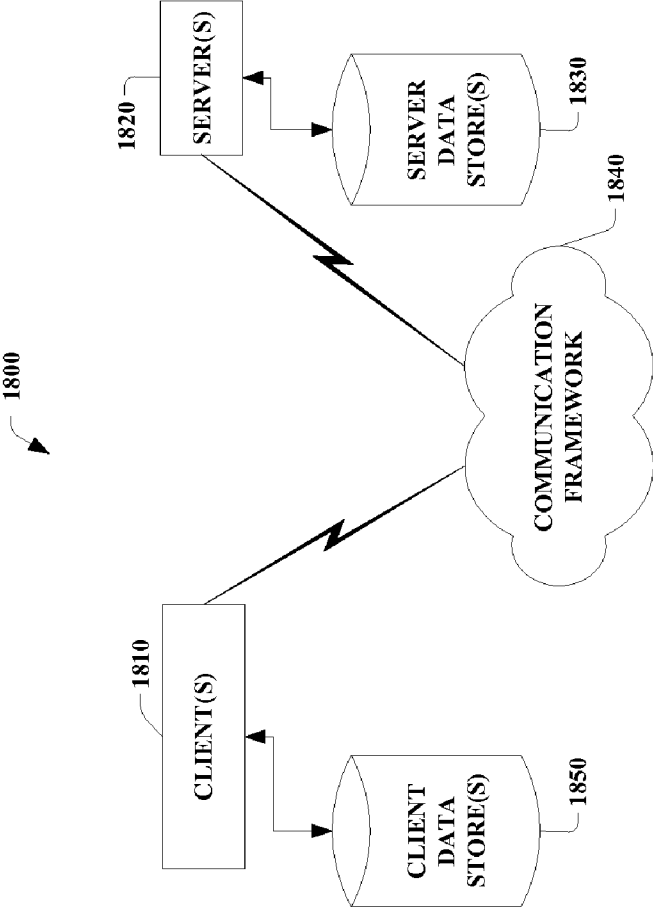

FIG. 18

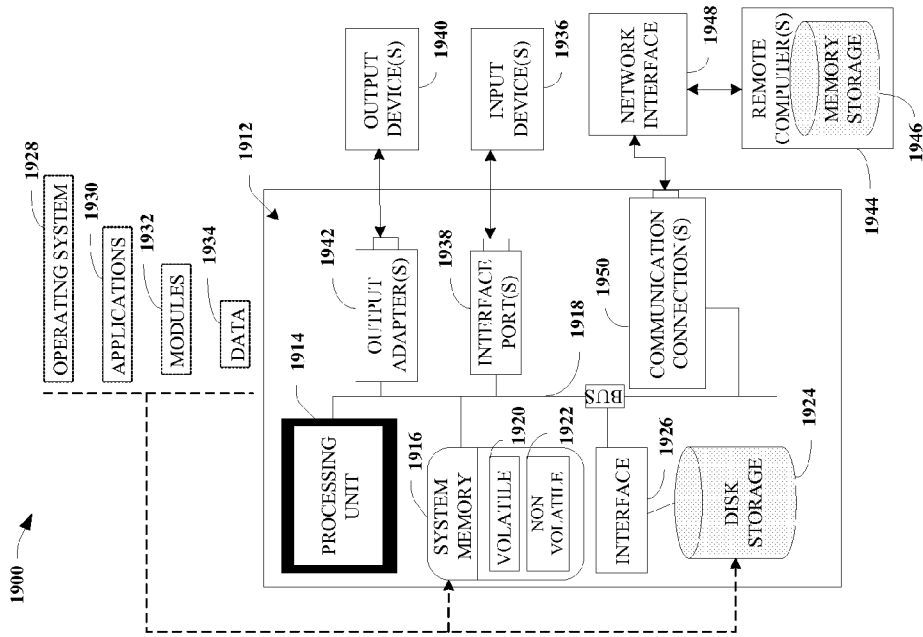

FIG. 19

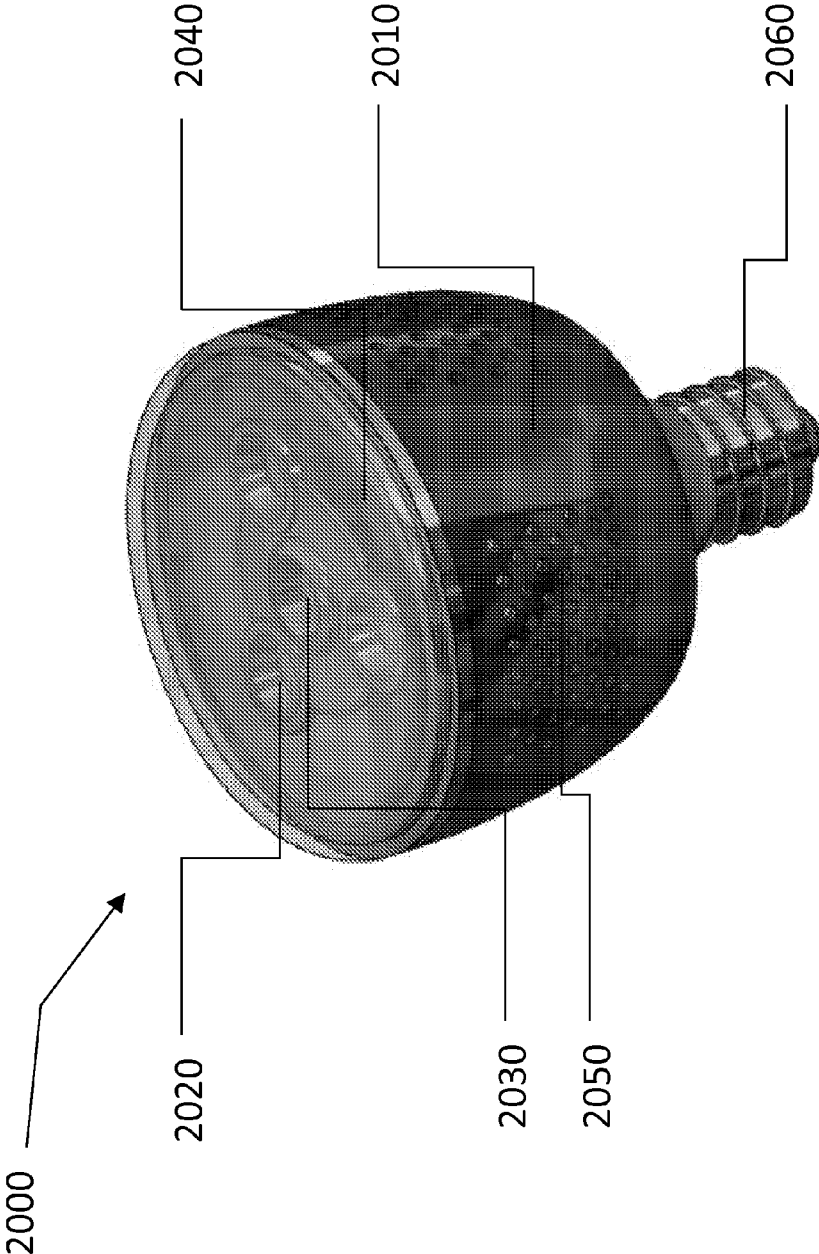

FIG. 20

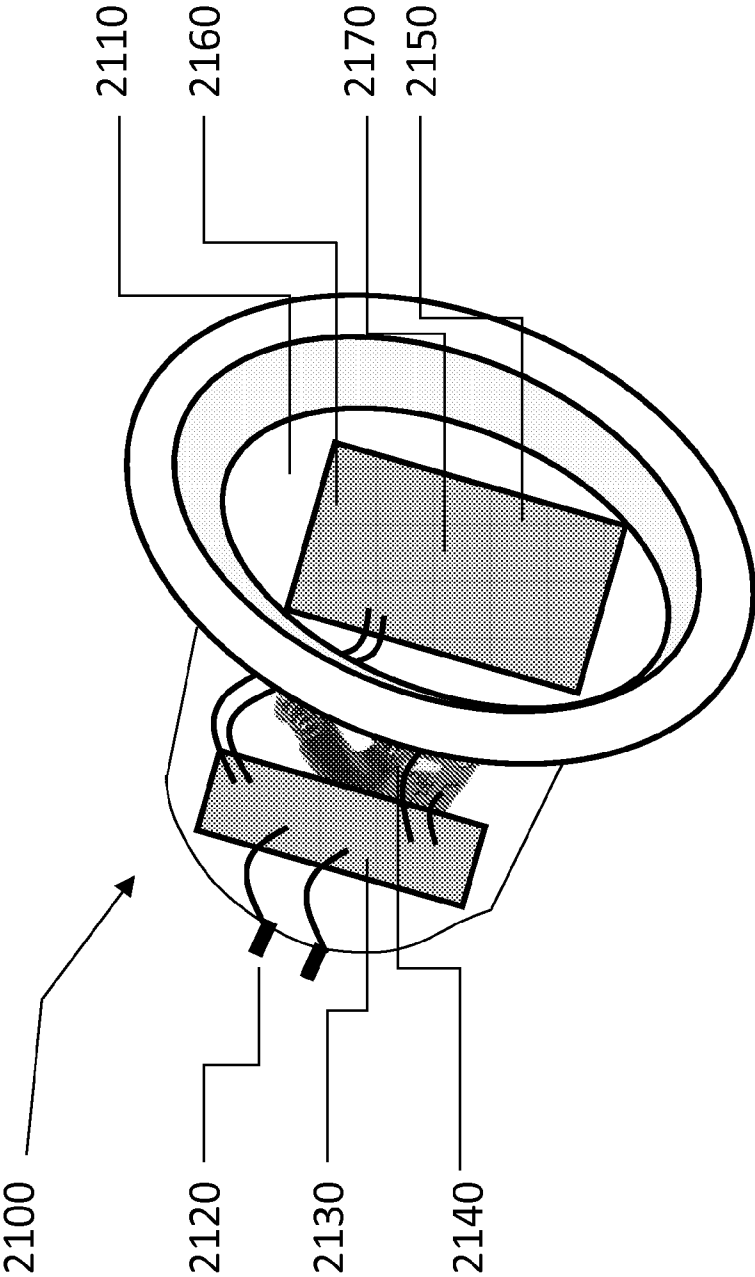

FIG. 21

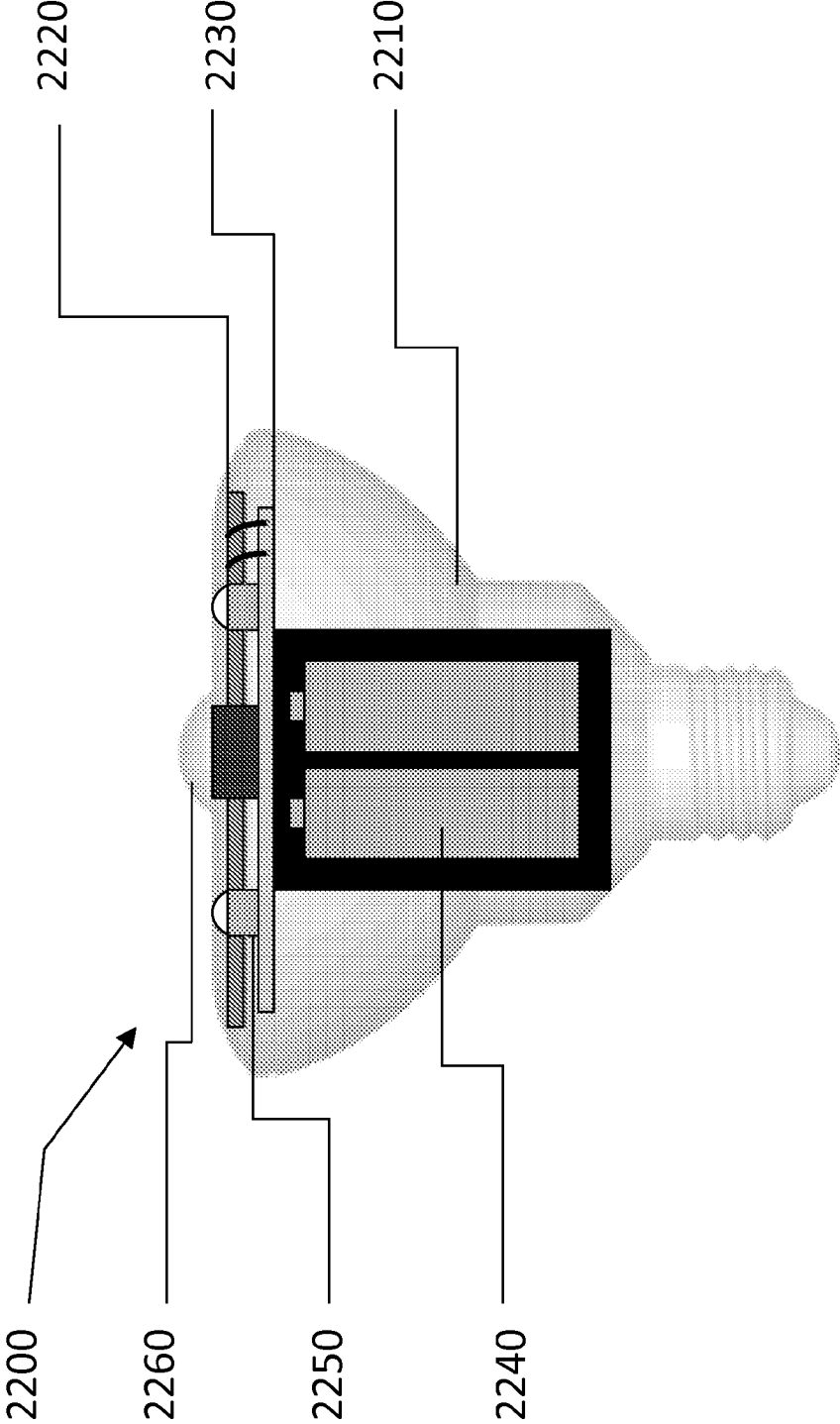

FIG. 22

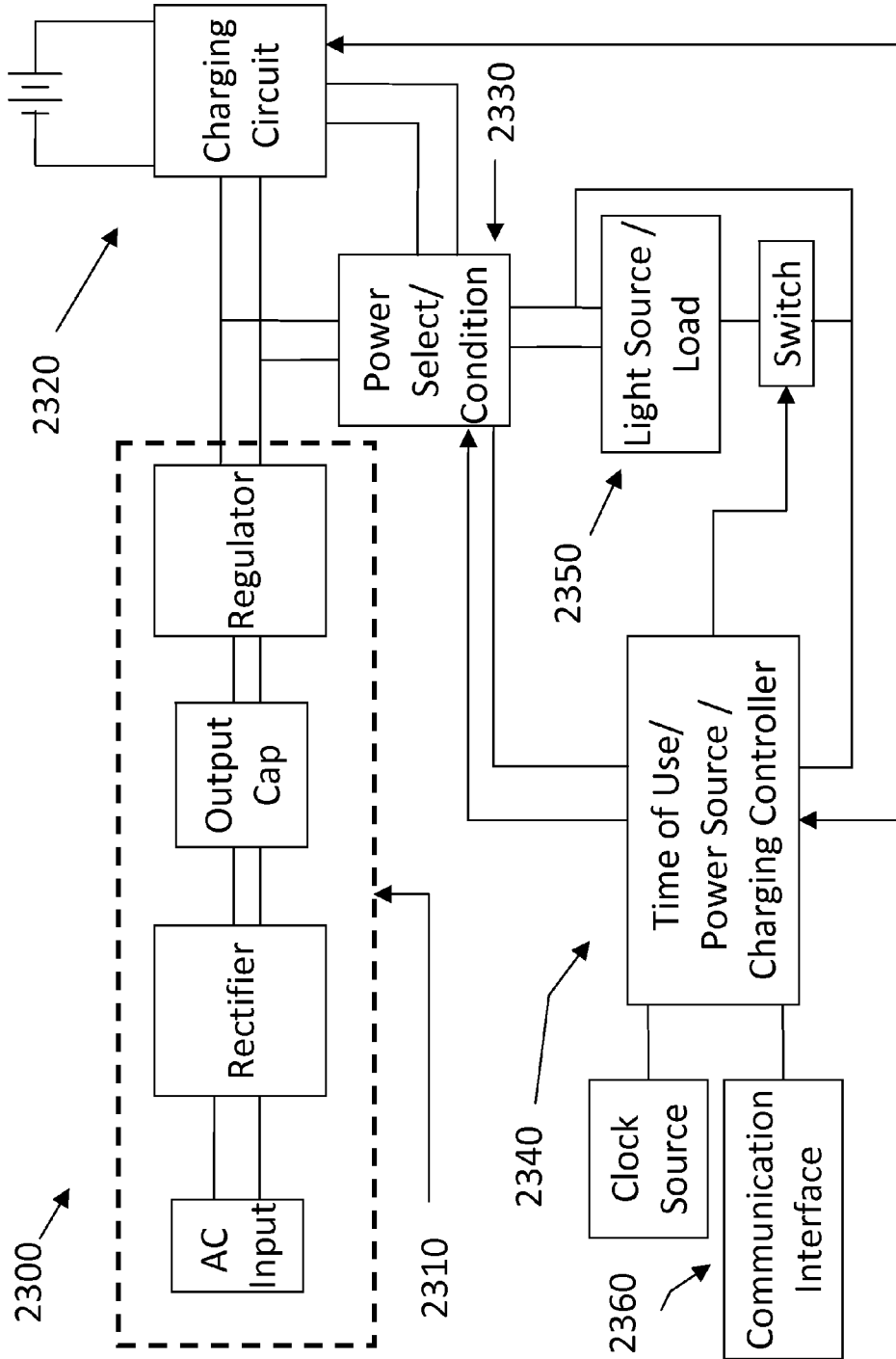

FIG. 23

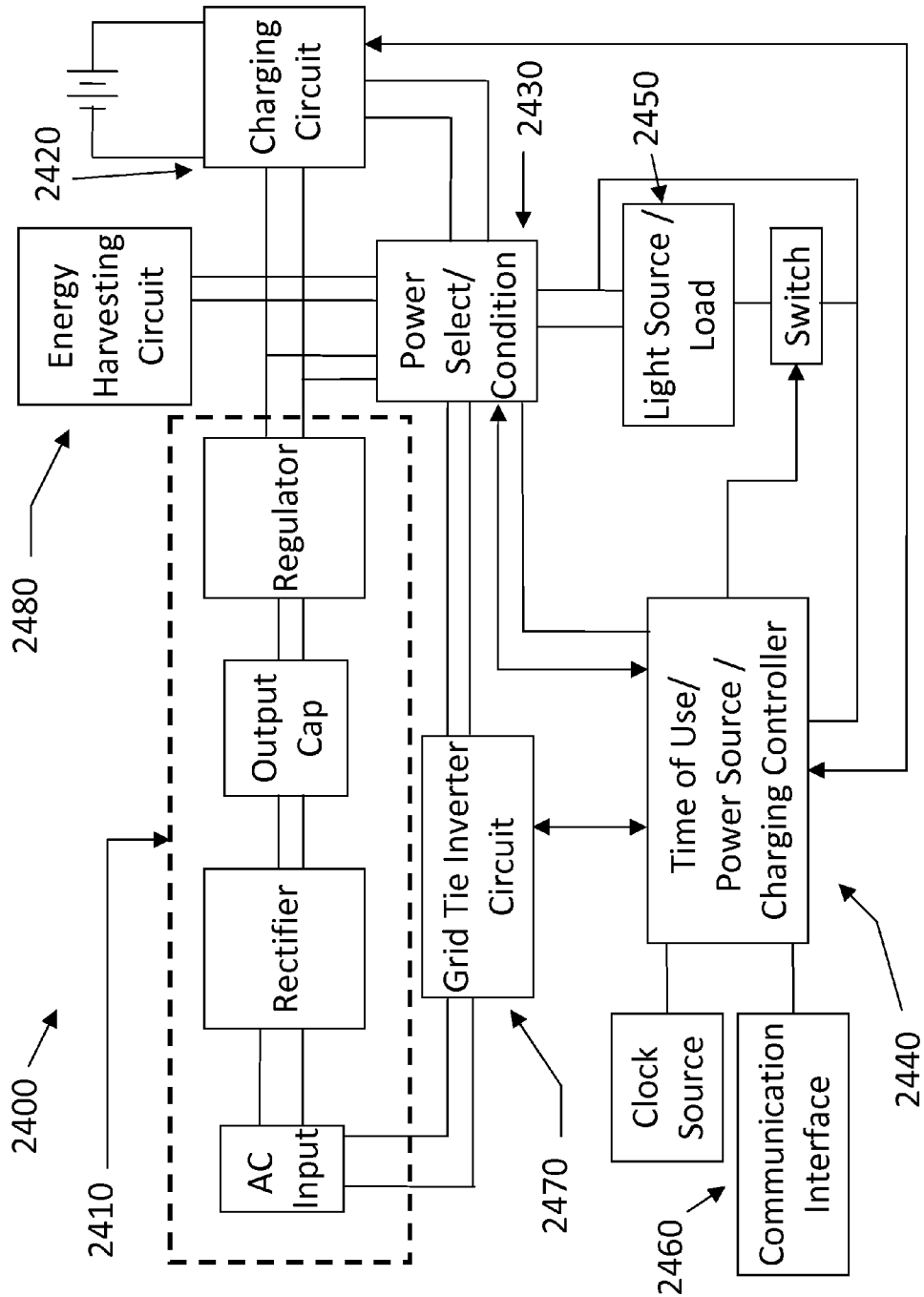

FIG. 24

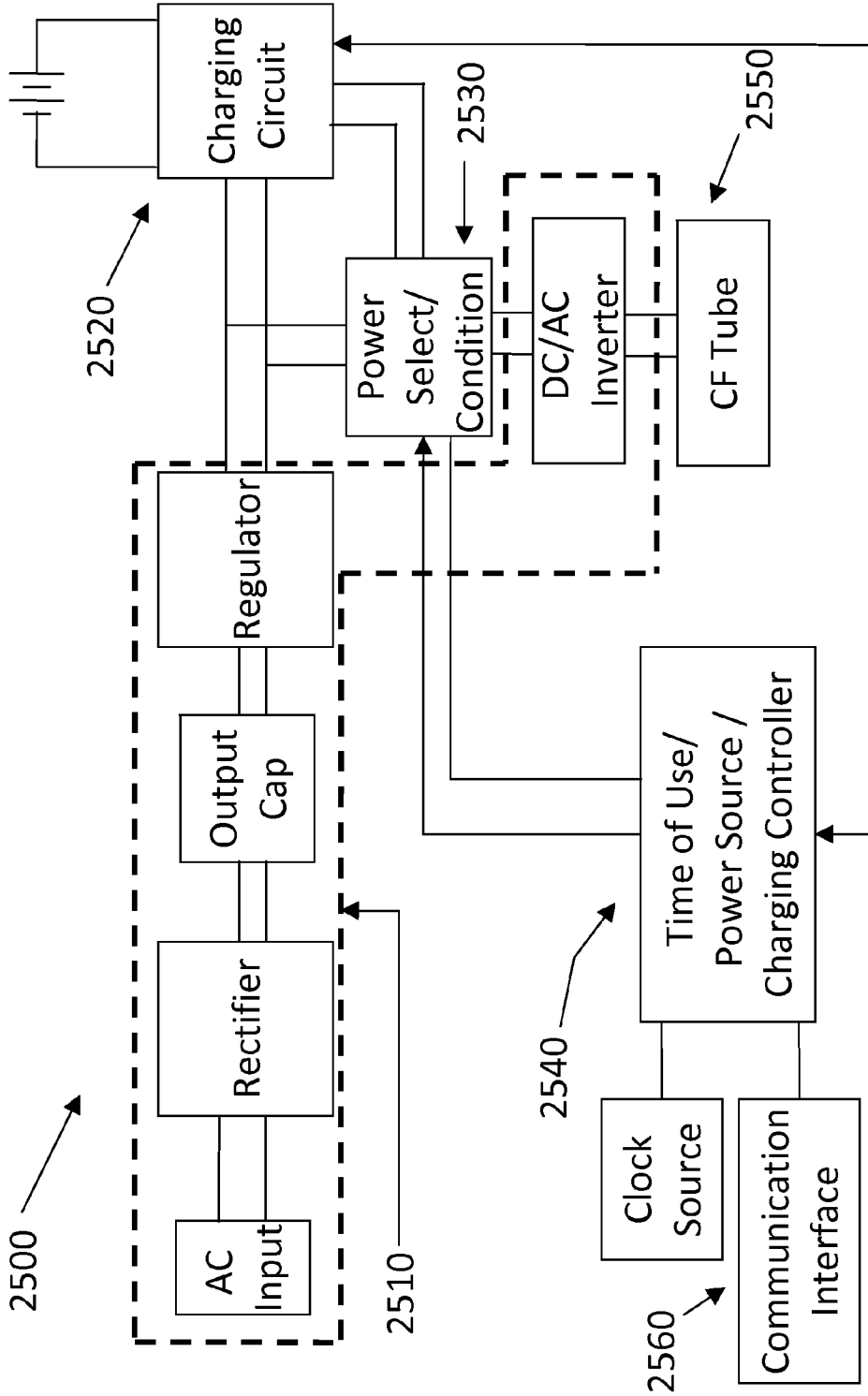

FIG. 25

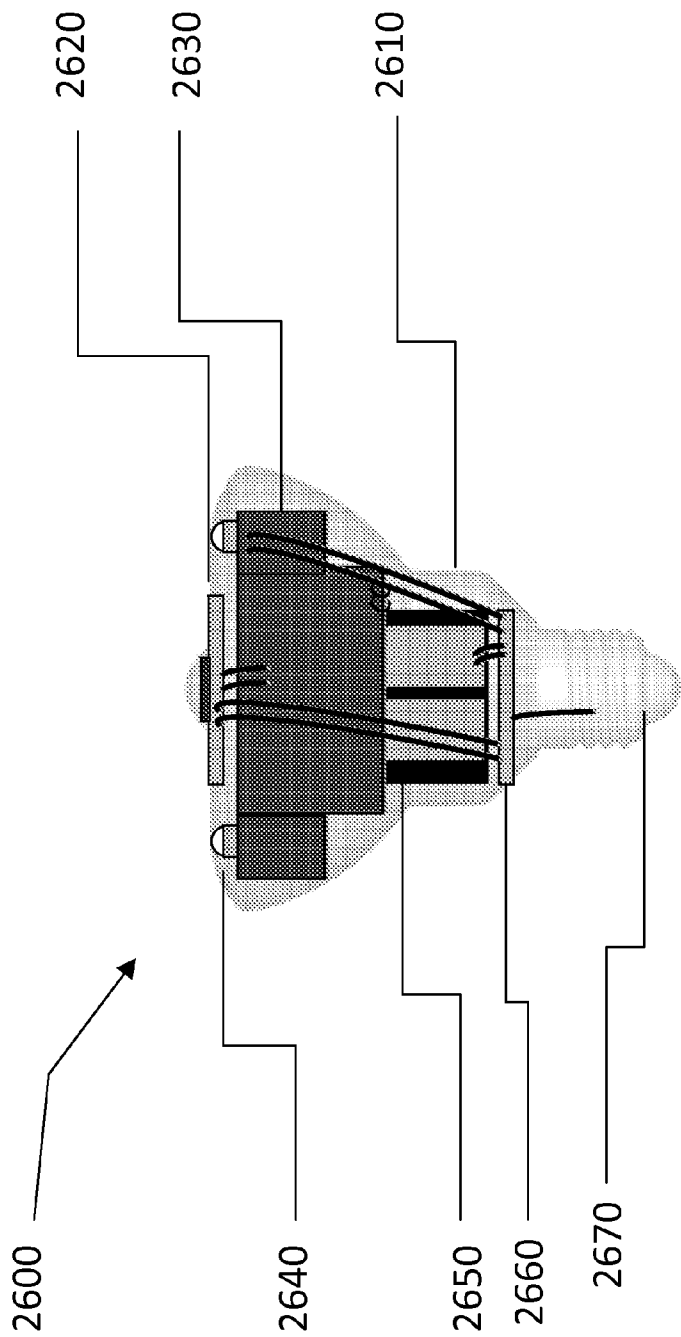

FIG. 26

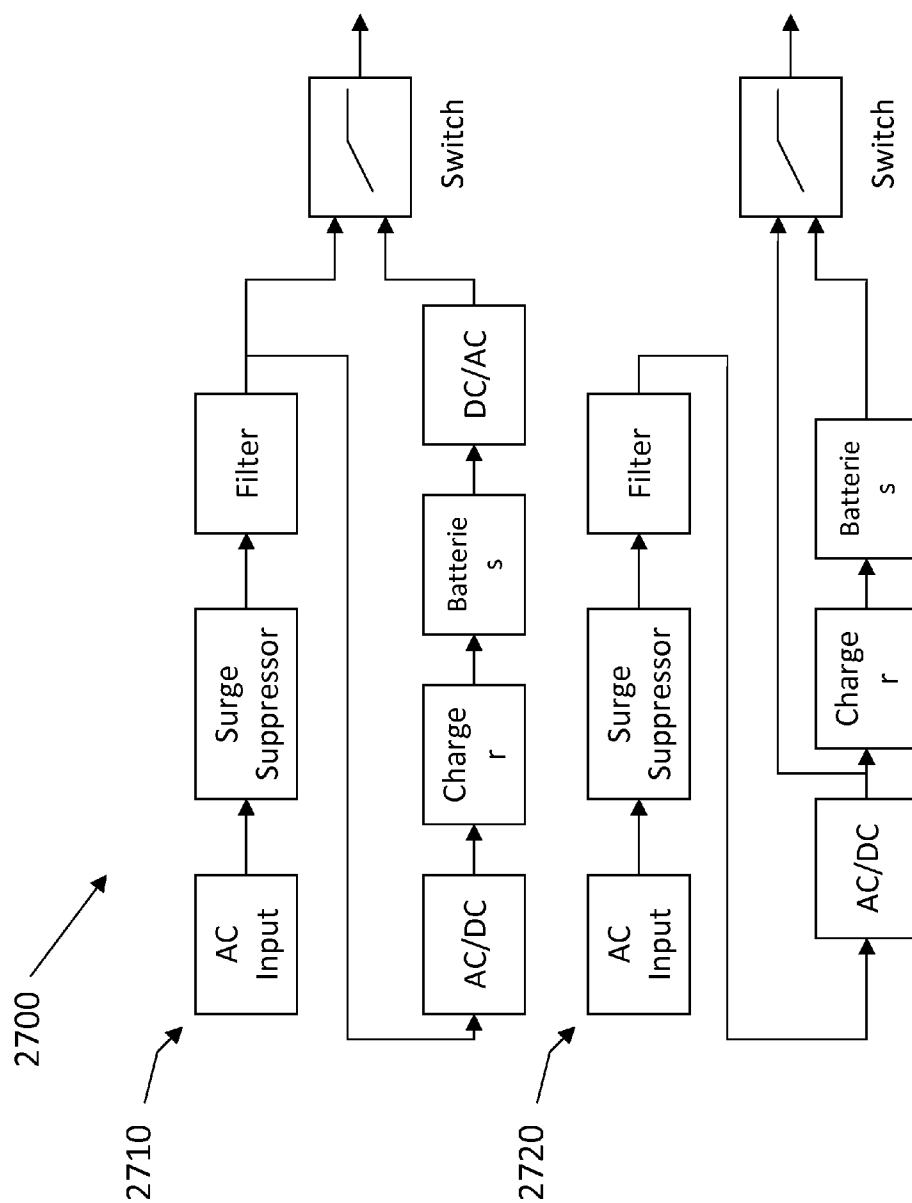

FIG. 27

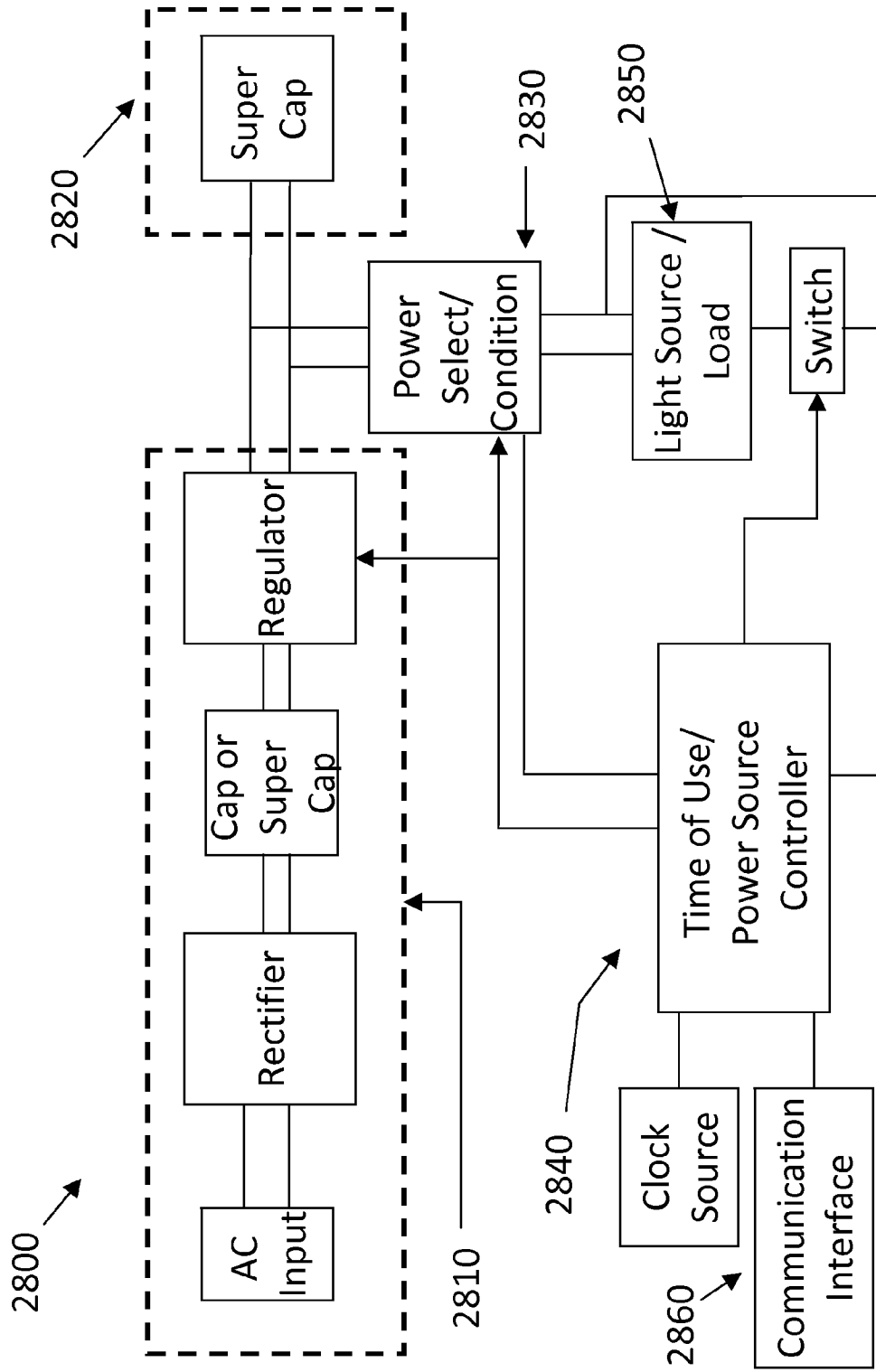

FIG. 28

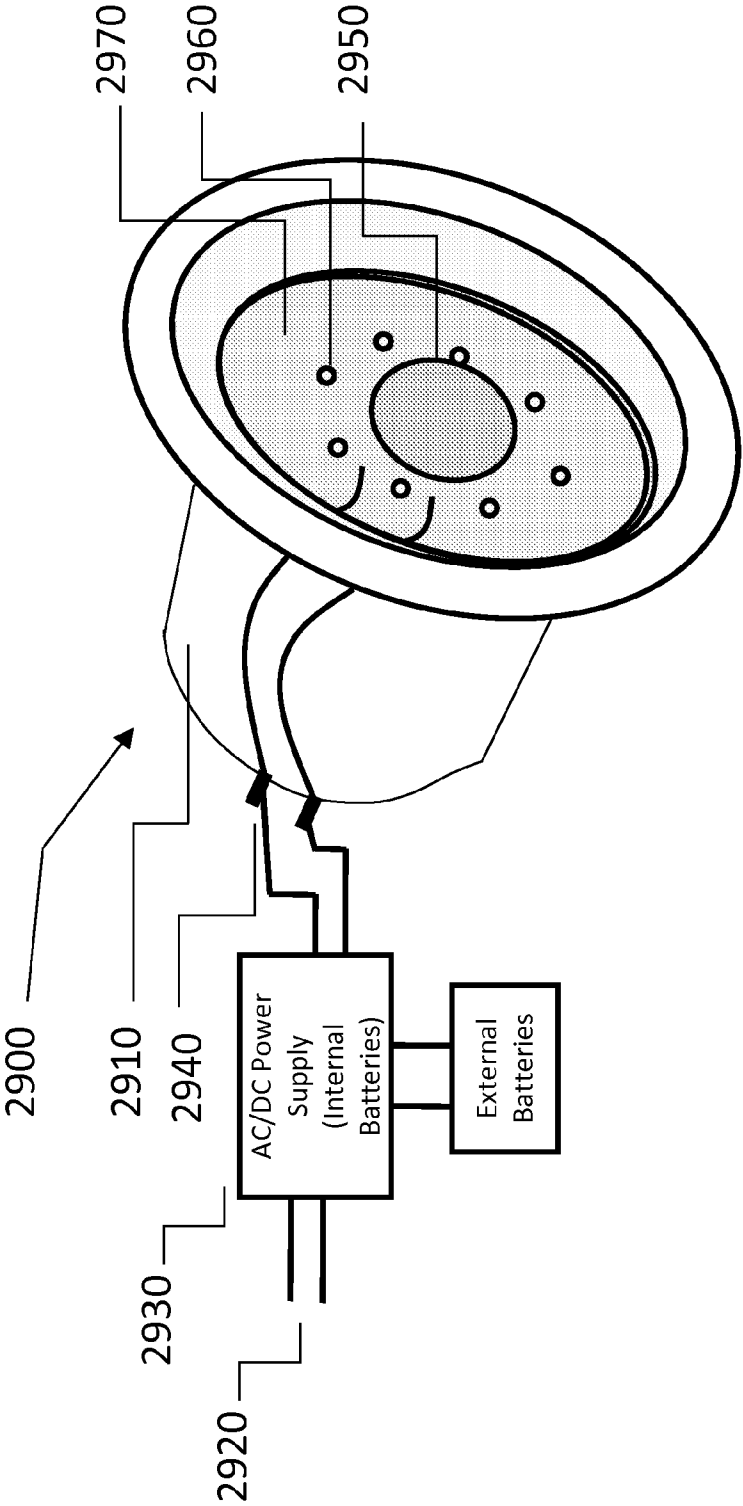

FIG. 29

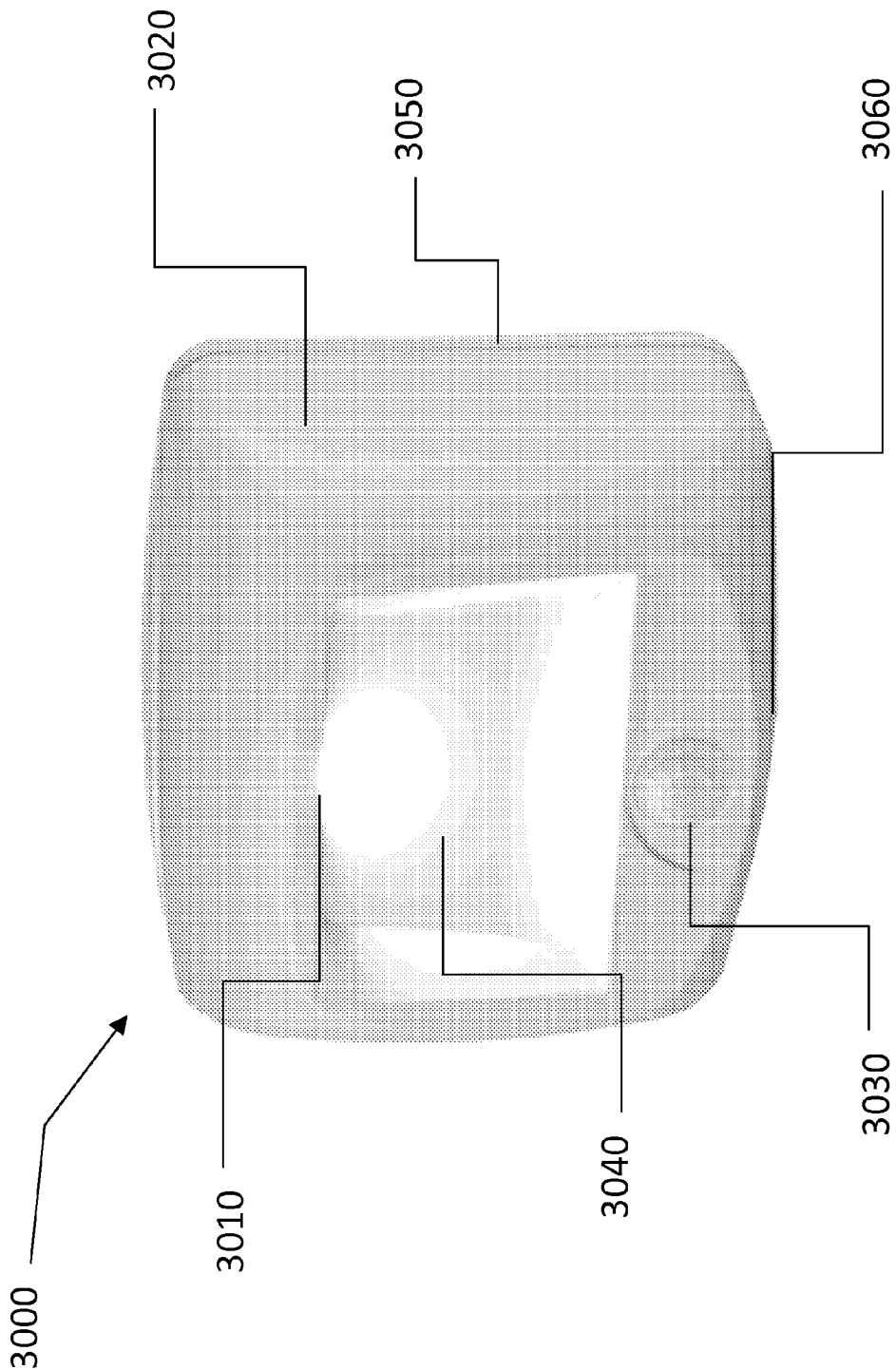

FIG. 30

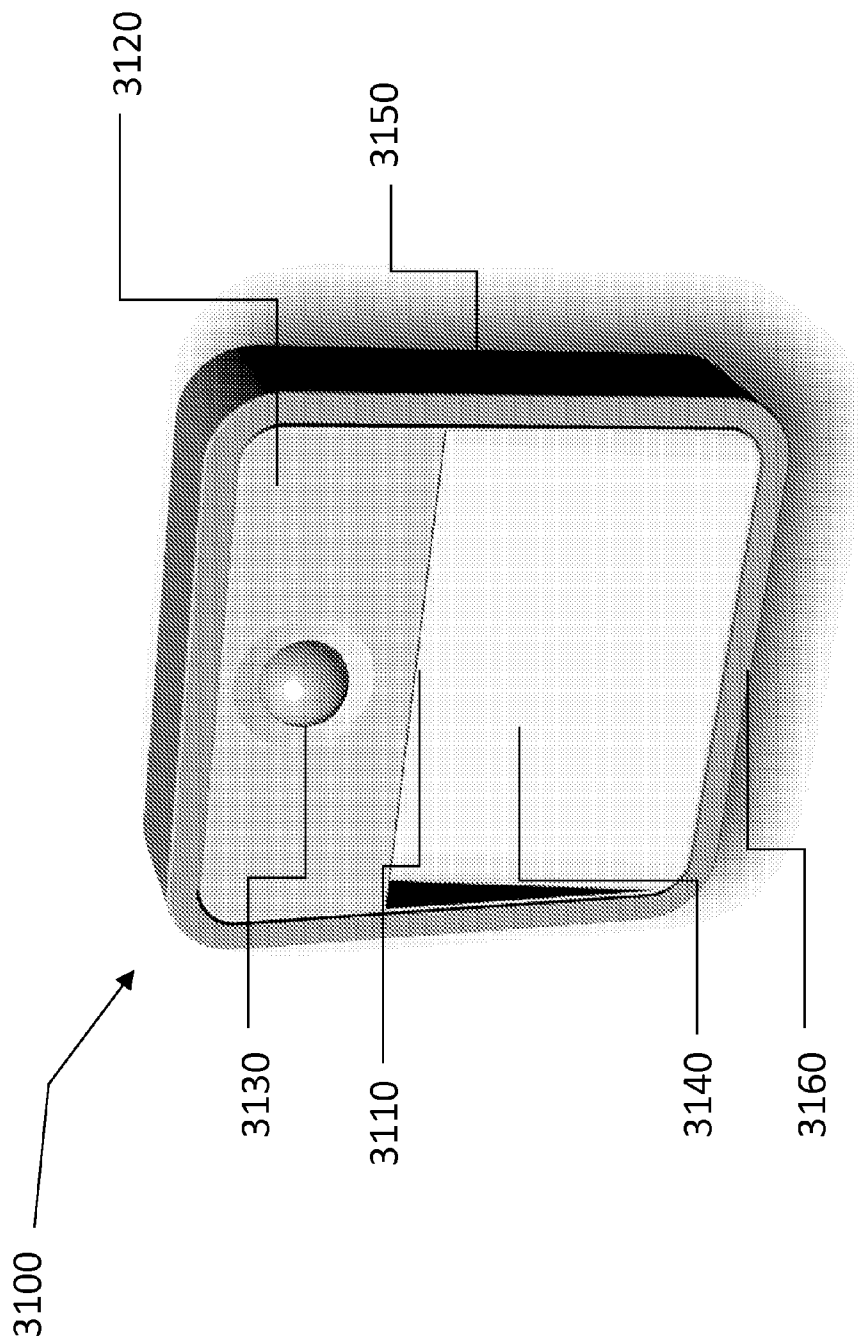

FIG. 31

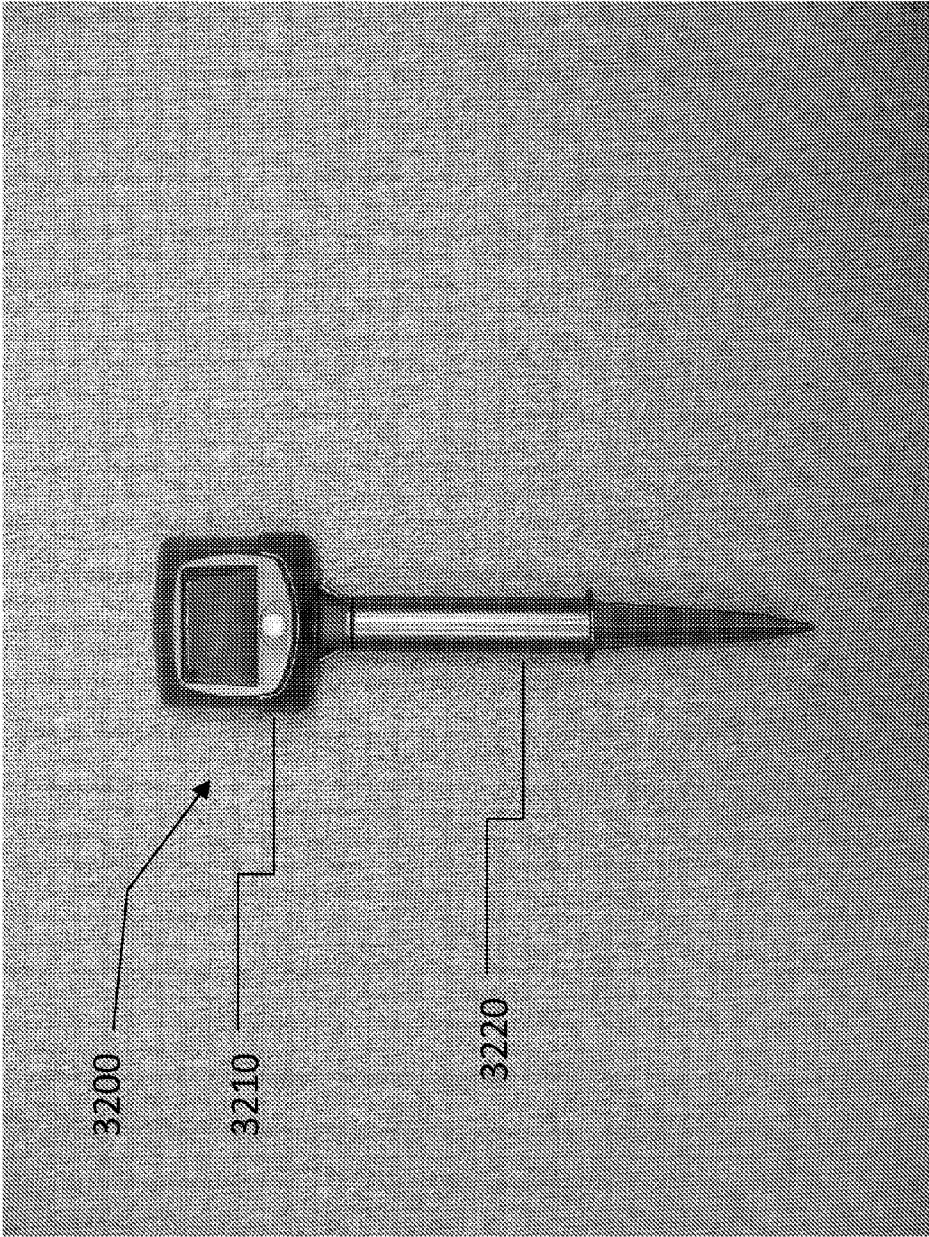

FIG. 32

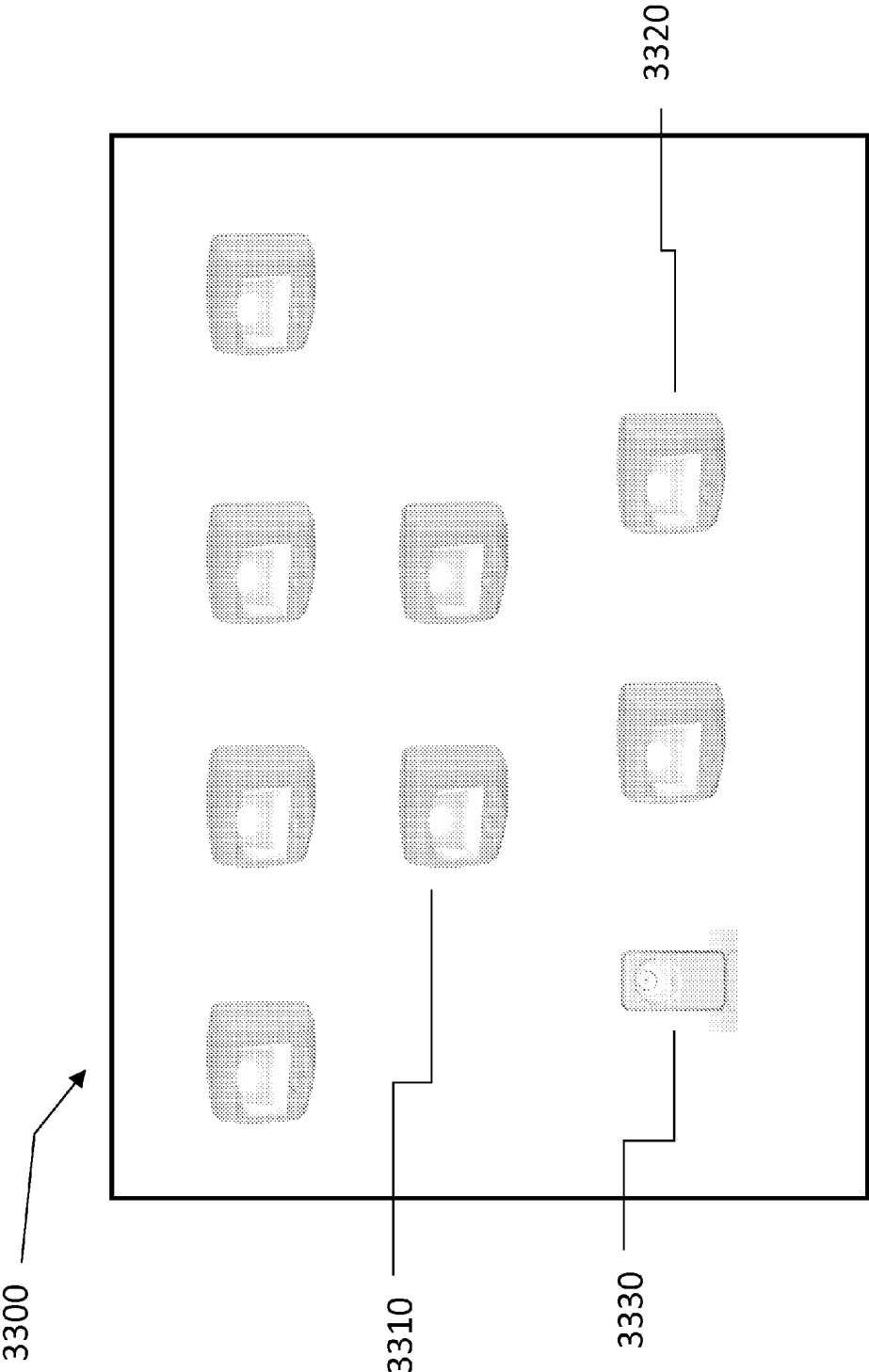

FIG. 33

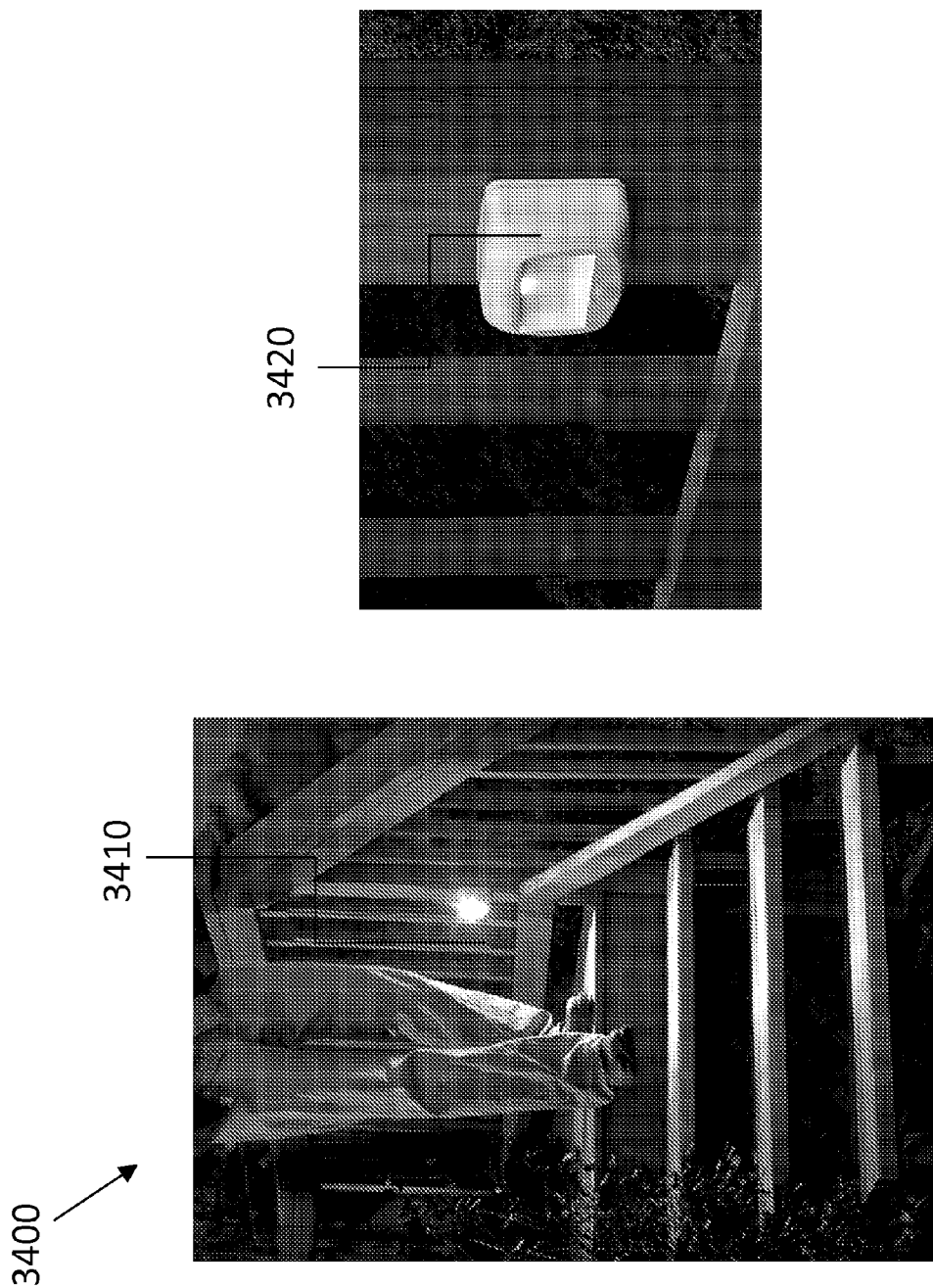
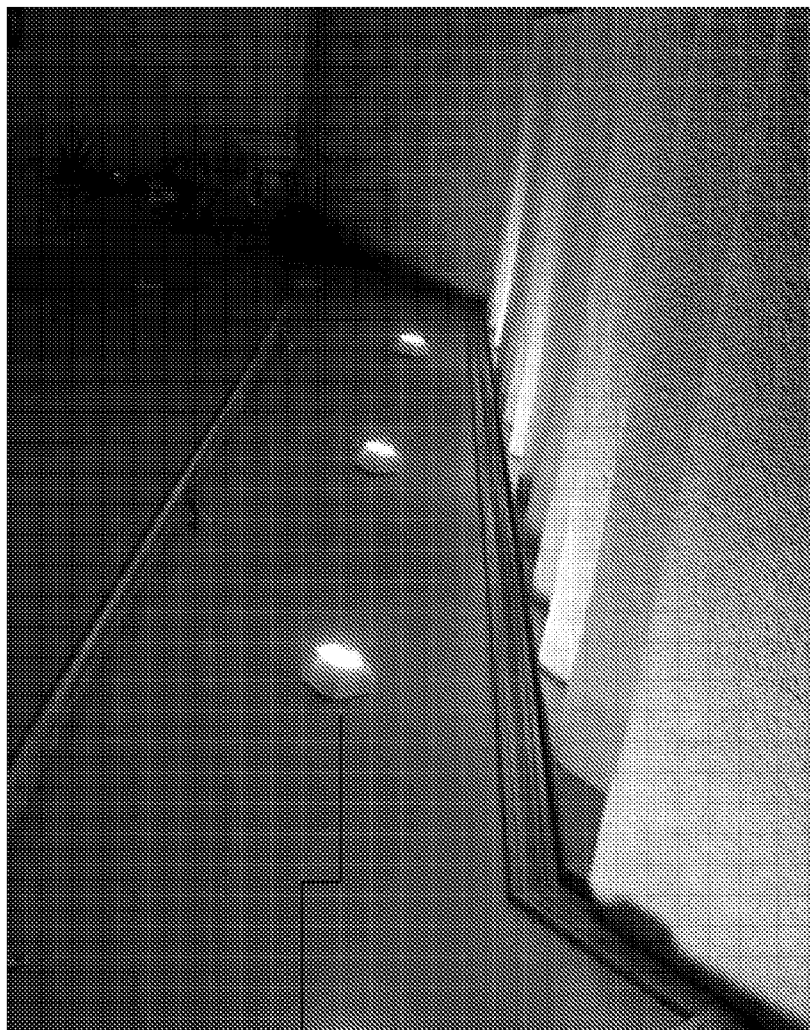
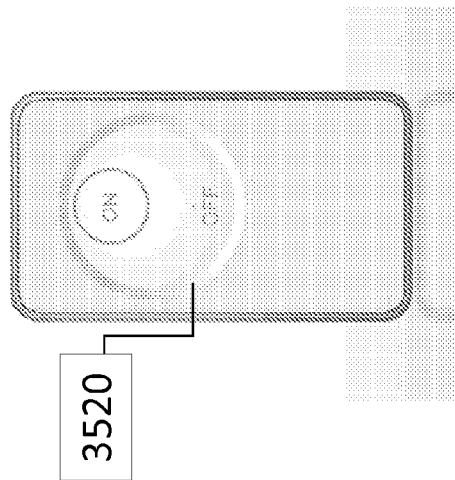

FIG. 34

3500



3510

FIG. 35

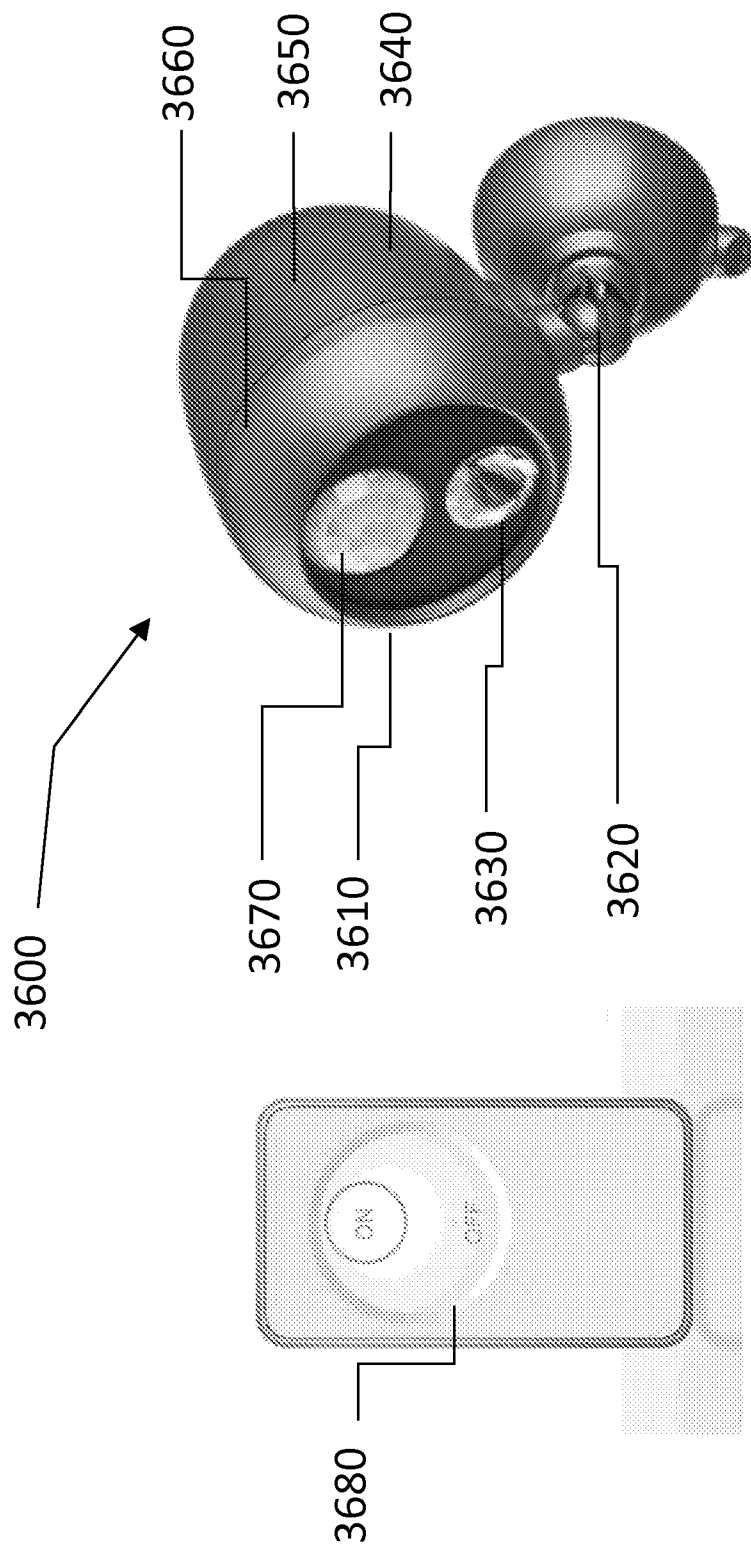

FIG. 36

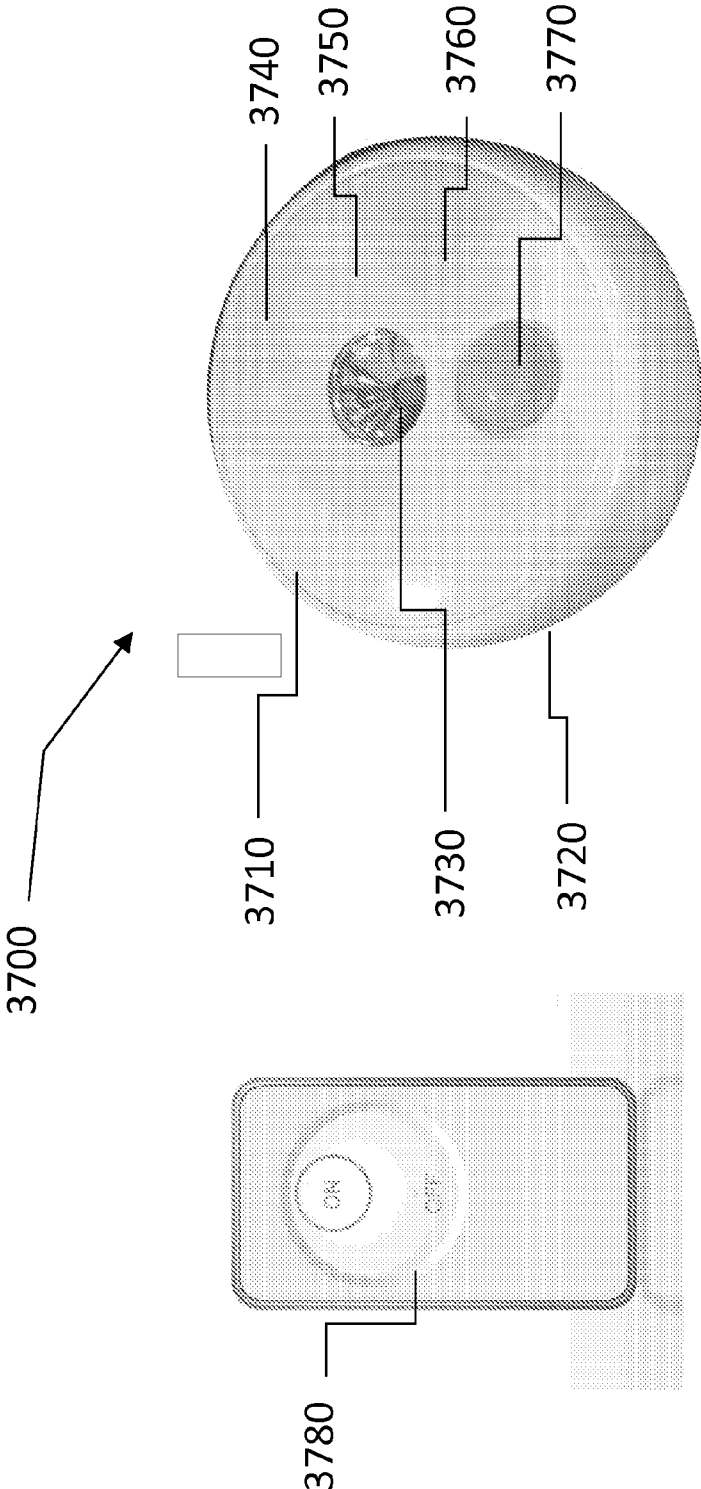

FIG. 37

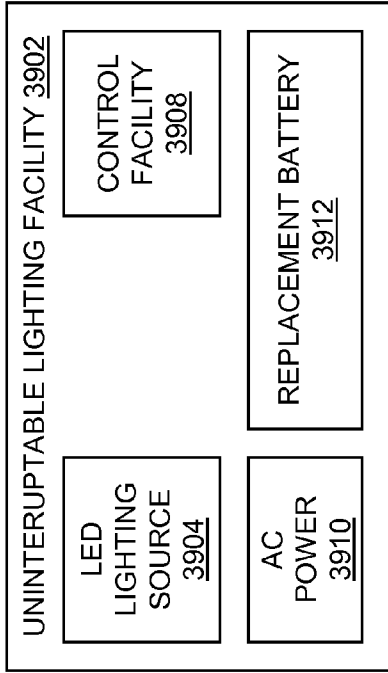

FIG. 39

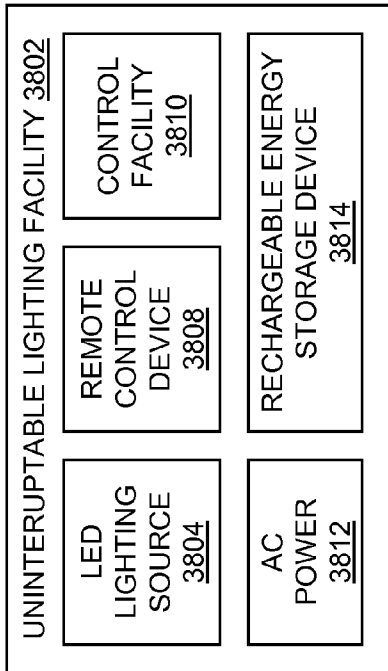

FIG. 38

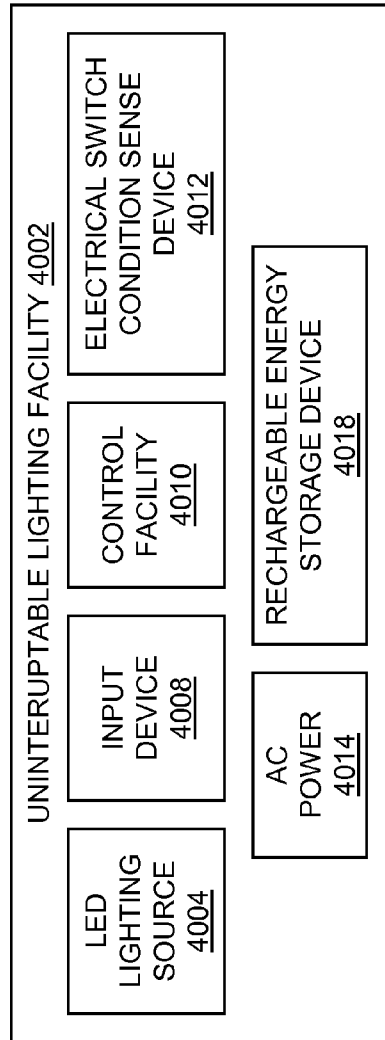

FIG. 40

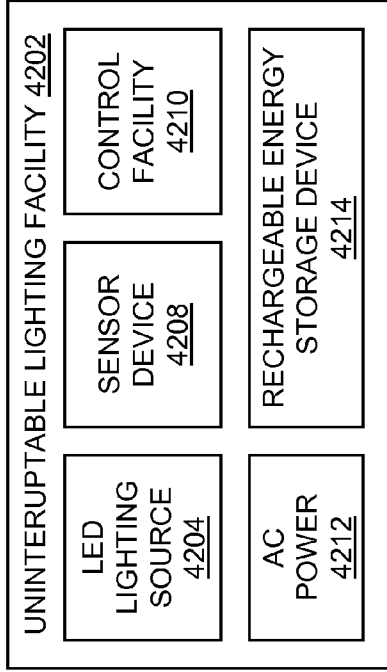

FIG. 42

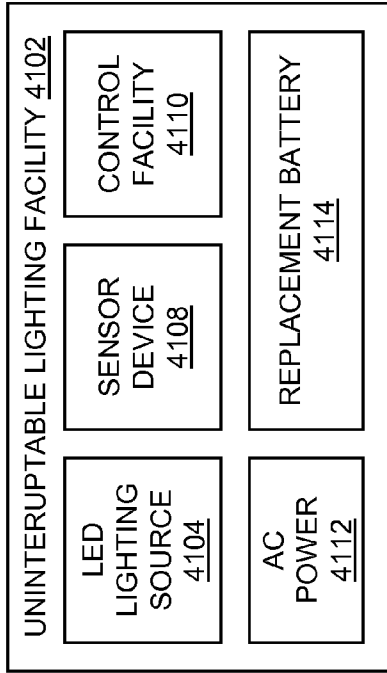

FIG. 41

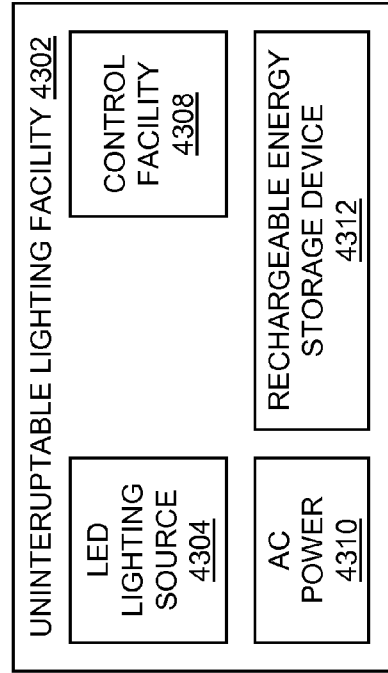

FIG. 43

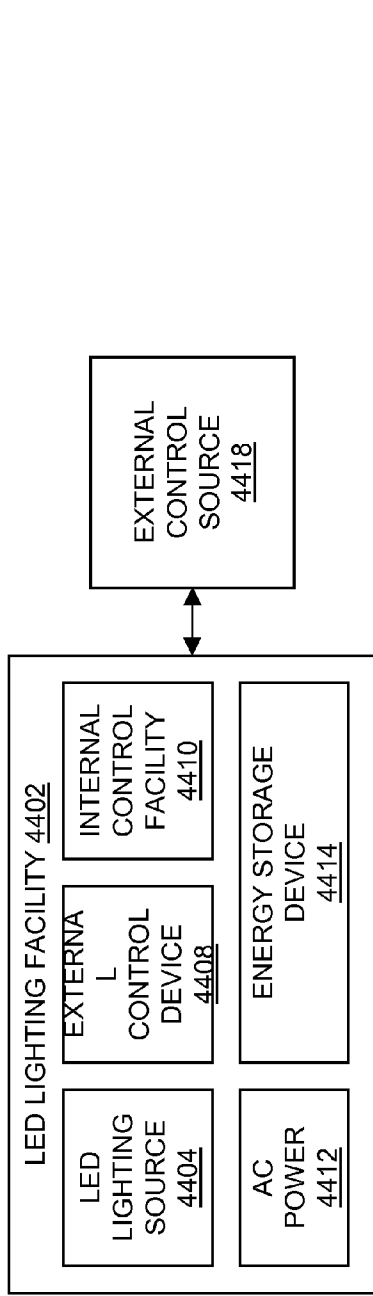

FIG. 44

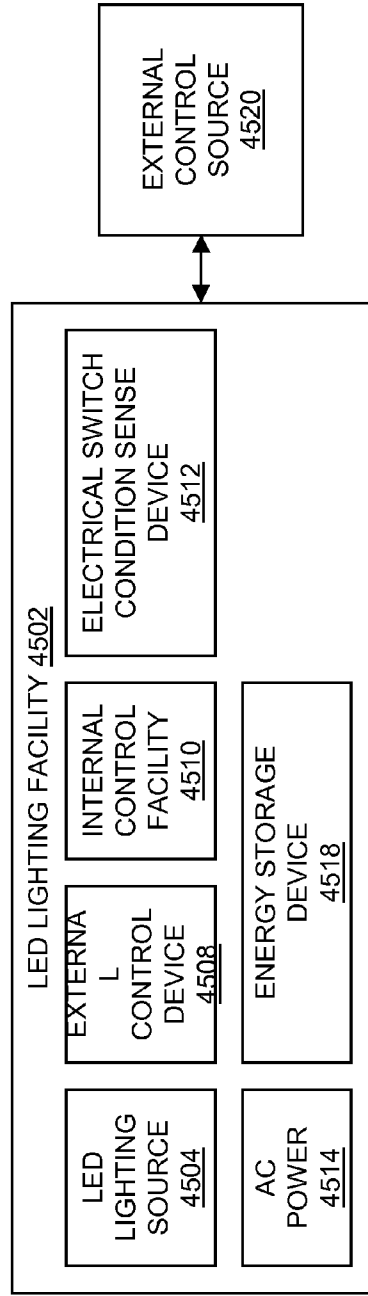

FIG. 45

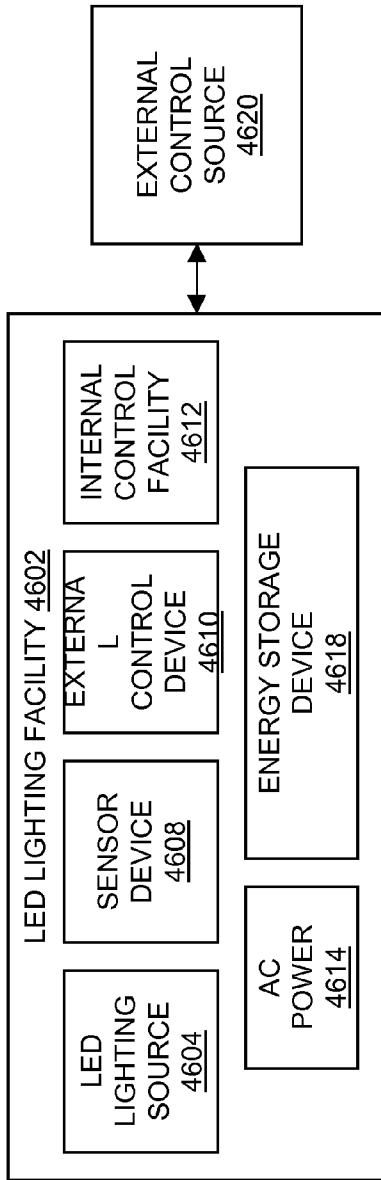

FIG. 46

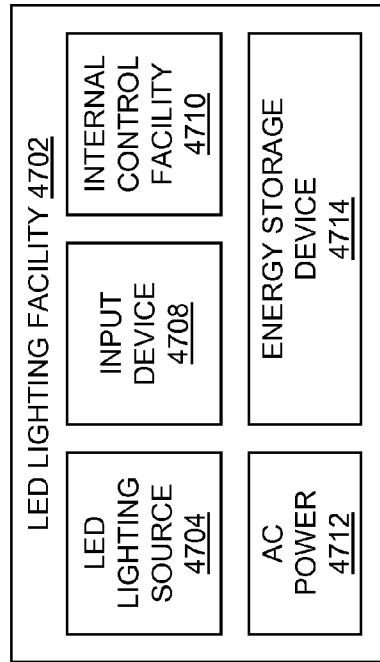

FIG. 47

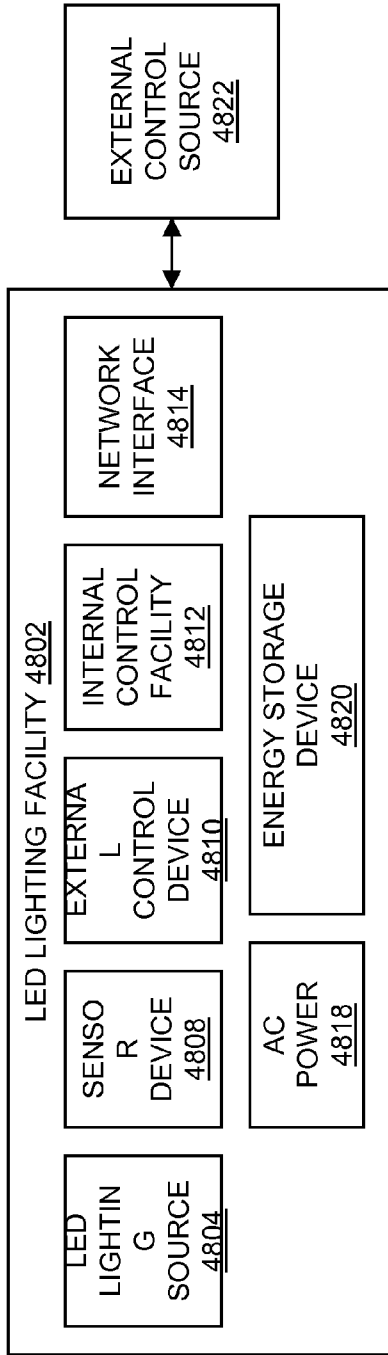

FIG. 48

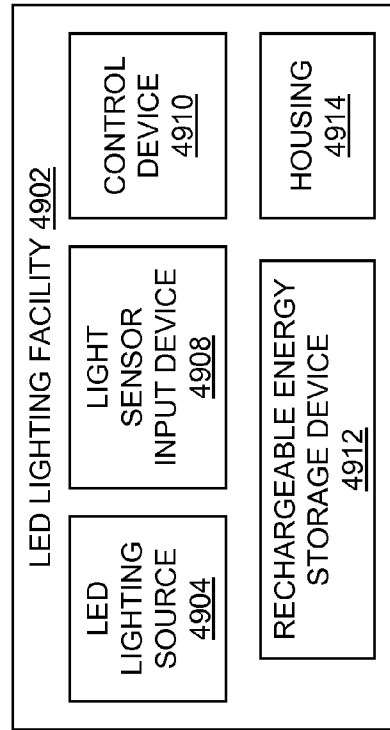

FIG. 49

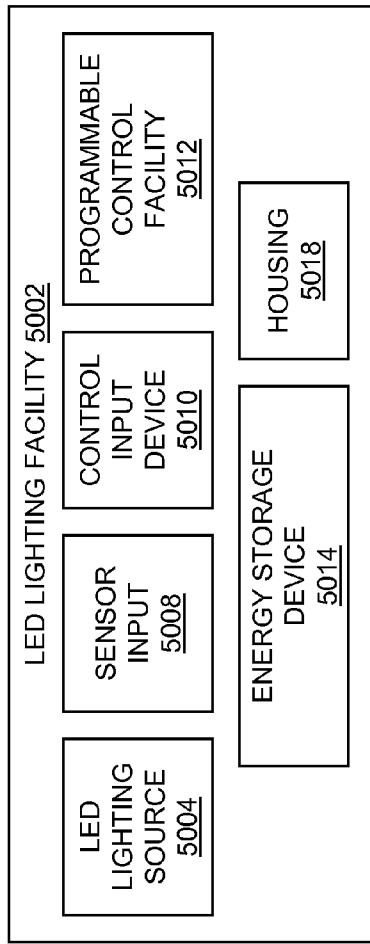

FIG. 50

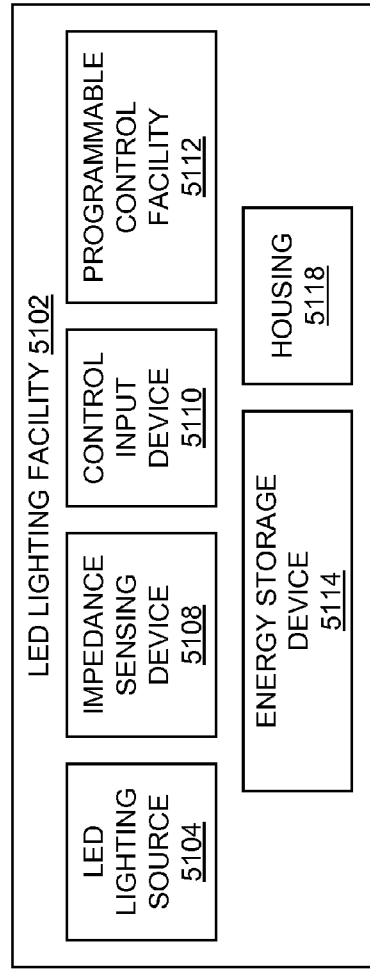

FIG. 51

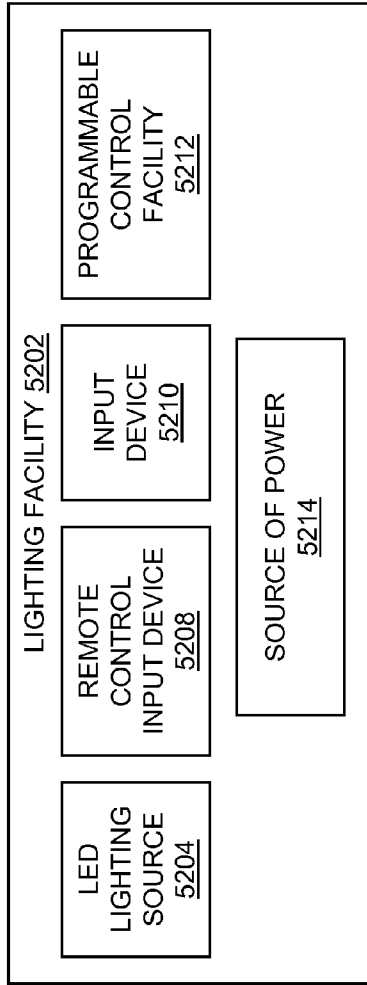

FIG. 52

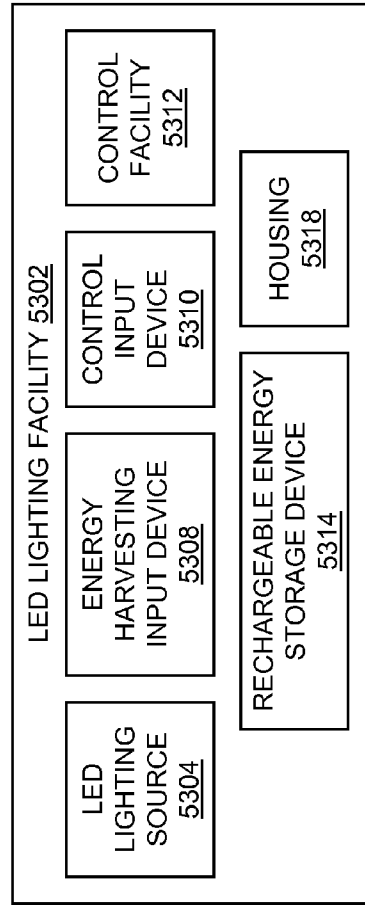

FIG. 53

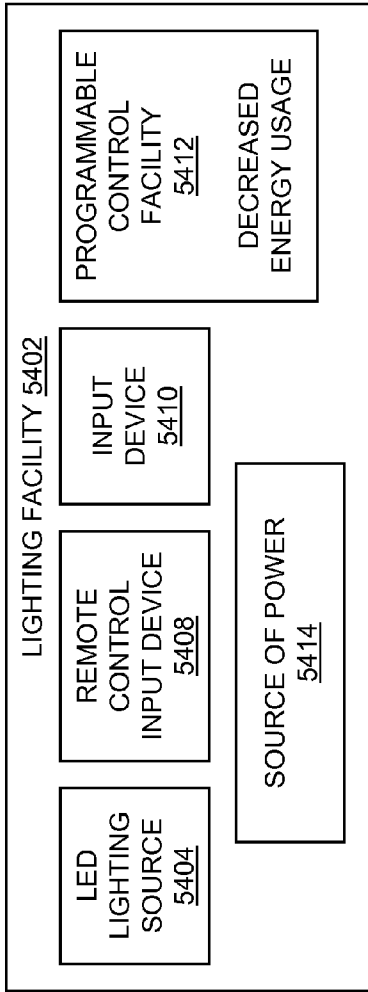

FIG. 54

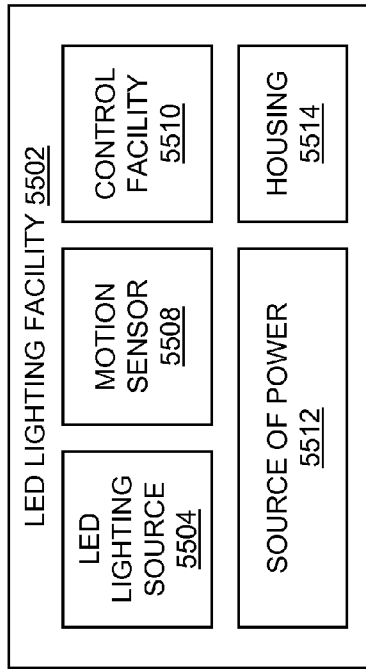

FIG. 55

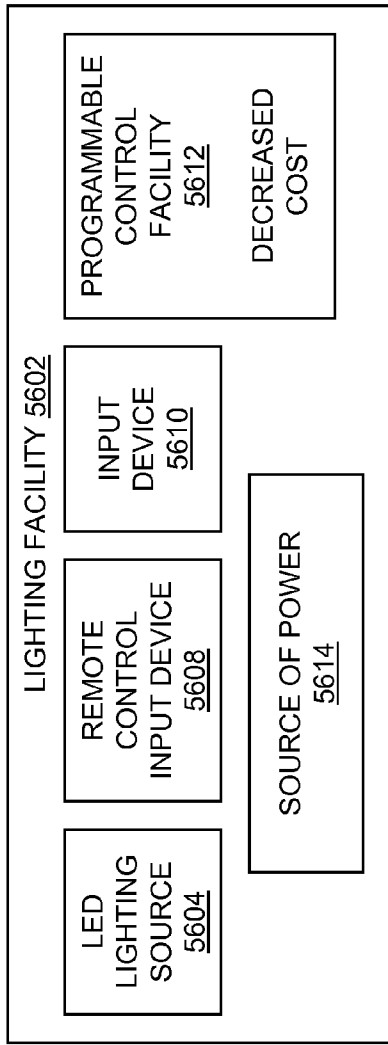

FIG. 56

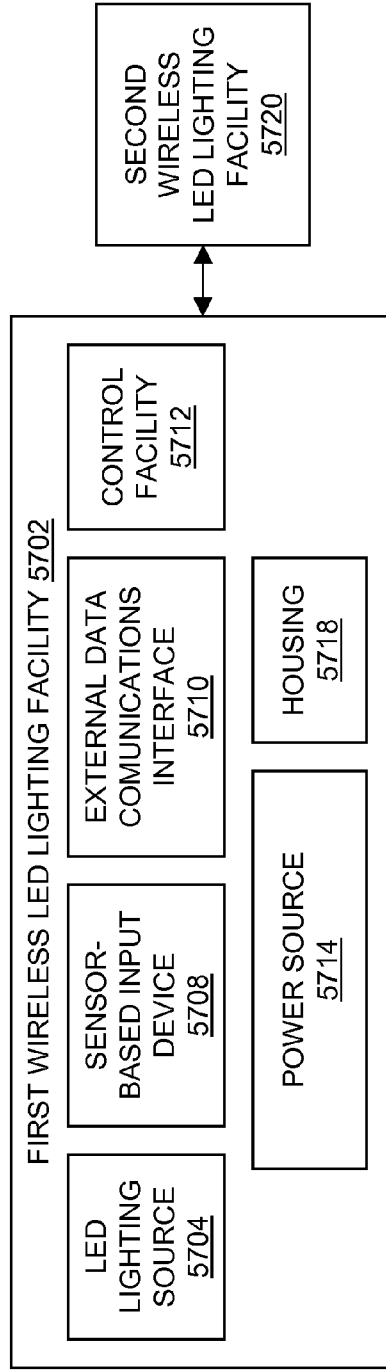

FIG. 57

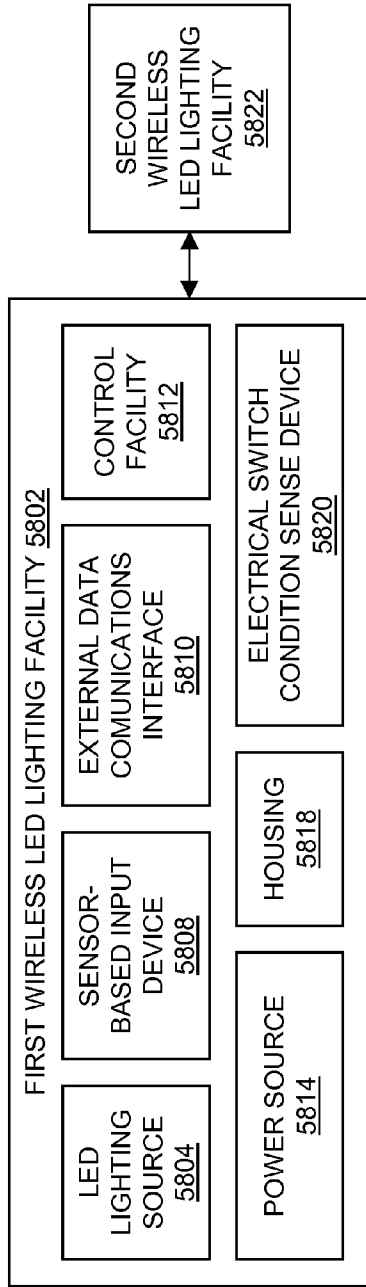

FIG. 58

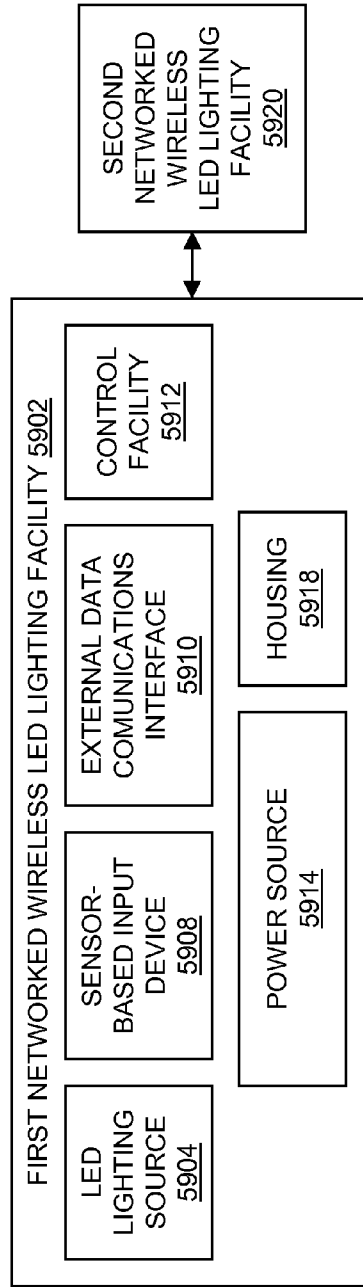

FIG. 59

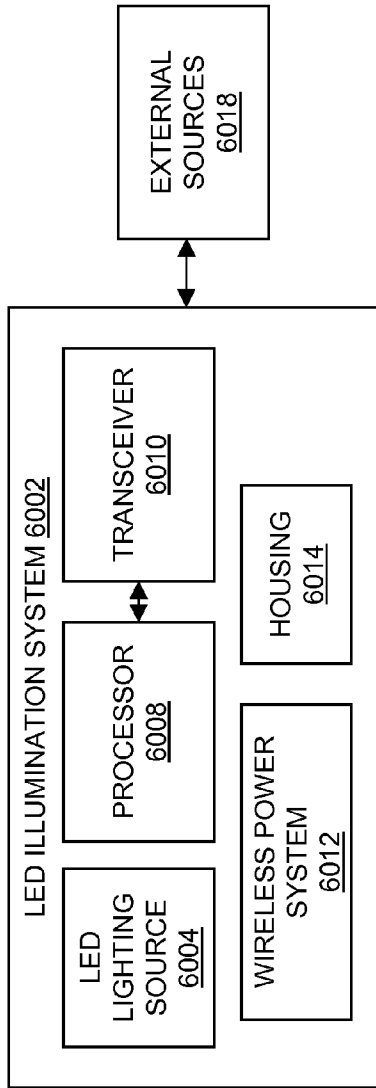

FIG. 60

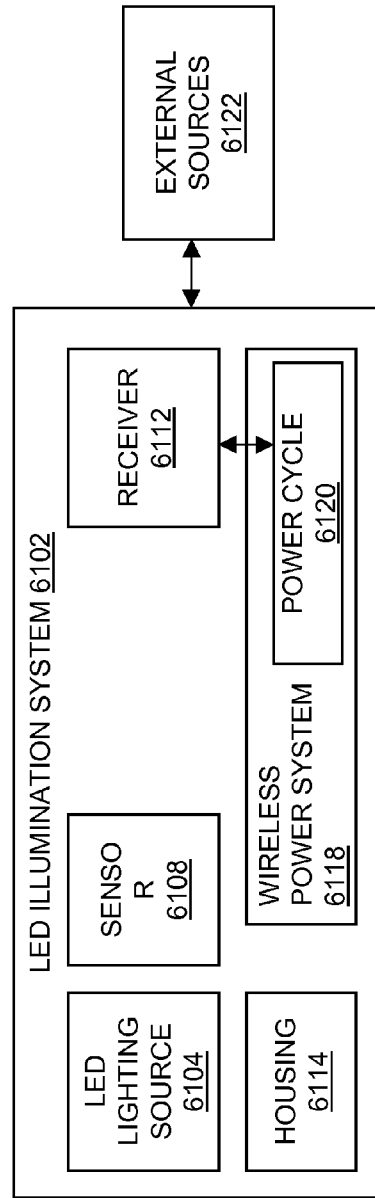

FIG. 61

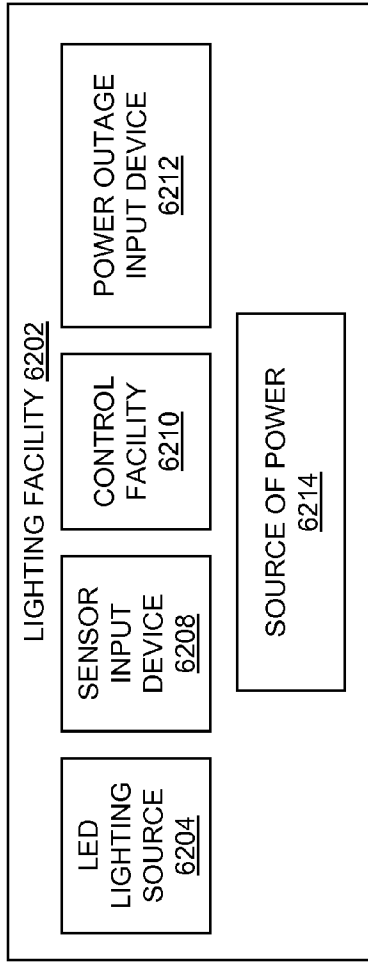

FIG. 62

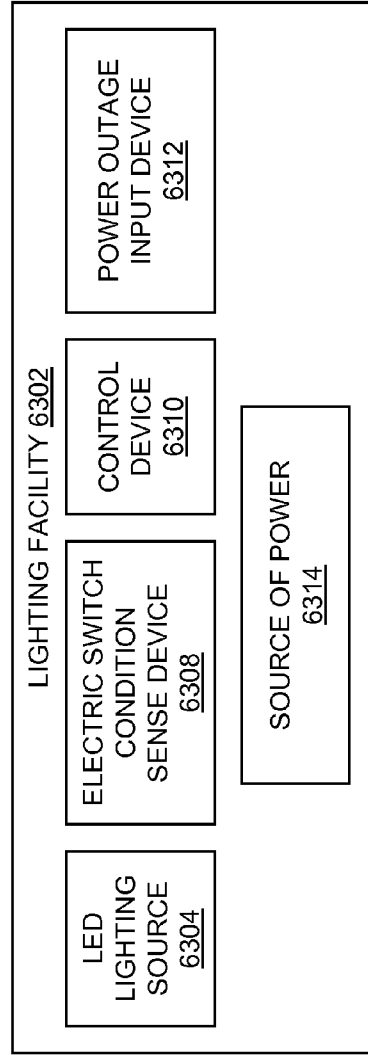

FIG. 63

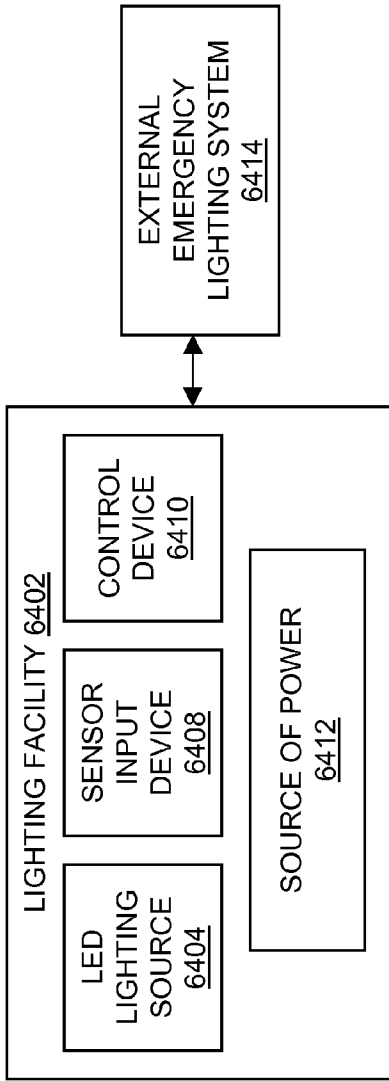

FIG. 64

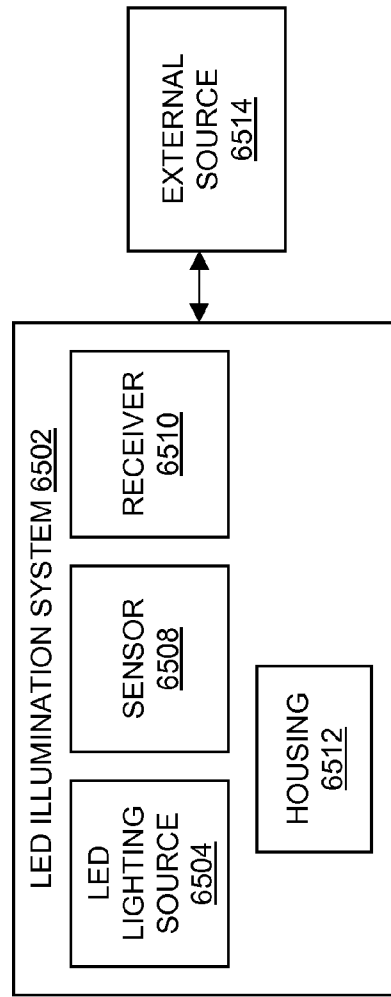

FIG. 65

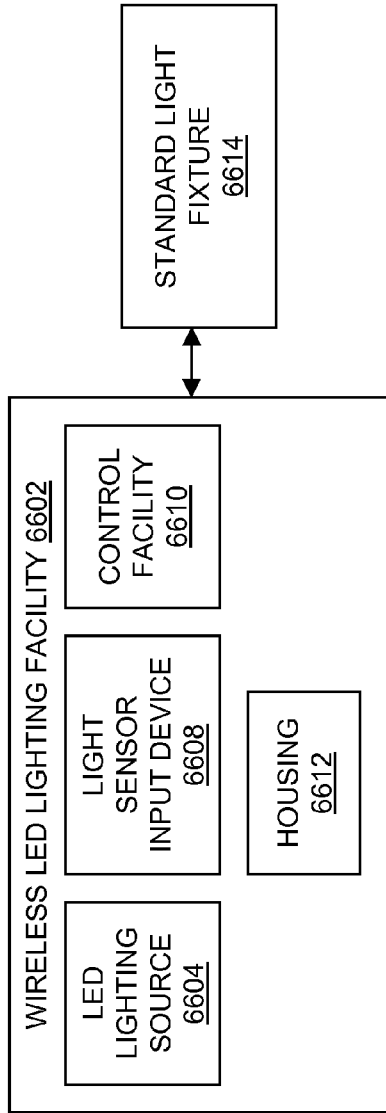

FIG. 66

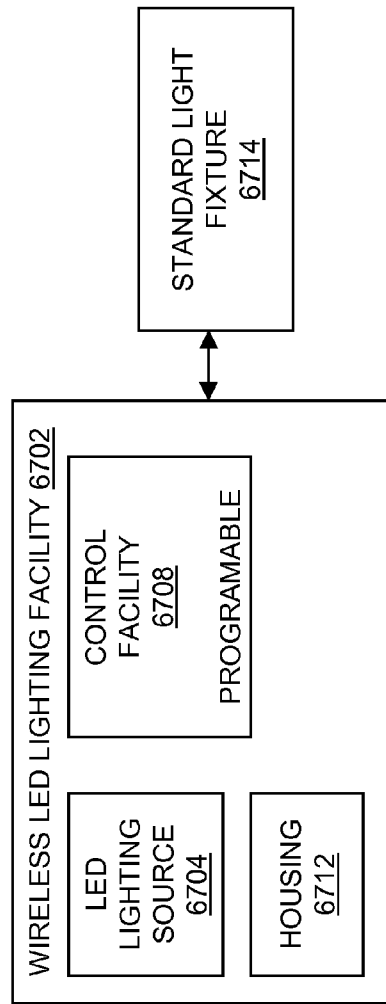

FIG. 67

WIRELESS POWER INVERTER FOR LIGHTING

CROSS-REFERENCE TO RELATED APPLICATIONS

[0001] This application claims the benefit of the following U.S. patent applications, each of which is hereby incorporated by reference in its entirety: U.S. Appl. No. 61/118,245 filed Nov. 26, 2008; U.S. Appl. No. 61/150,477 filed Feb. 6, 2009; U.S. Appl. No. 61/167,556 filed Apr. 8, 2009; U.S. Appl. No. 61/186,097 filed Jun. 11, 2009; U.S. Appl. No. 61/234,024 filed Aug. 14, 2009; U.S. Appl. No. 61/246,362 filed Sep. 28, 2009; U.S. Appl. No. 61/118,257 filed Nov. 26, 2008; and U.S. Appl. No. 61/167,655 filed Apr. 8, 2009.

BACKGROUND

[0002] 1. Field

[0003] The present invention is directed generally to devices and applications for the use of wireless control and wireless power in lighting devices. More particularly, the invention relates to the use of wireless control and wireless power in light emitting diode (LED) based devices primarily for illumination purposes.

[0004] 2. Description of the Related Art

[0005] Conservation and management of electrical power are a growing concern with regard to both cost and environmental impact. In various lighting applications, the use of light emitting diodes (LEDs) for illumination is beginning to emerge as a lighting source with potential for addressing these concerns. LED light sources have a long life, are energy efficient, are durable and operate over a wide temperature range. While LED lighting is becoming an attractive option for certain applications, it is not optimal for many applications. Therefore, there is a need for improved LED lighting systems.

SUMMARY

[0006] The present invention is directed generally to devices and applications related to the use of wireless control and wireless power in light emitting diode (LED) based lighting devices. More particularly, the devices and applications according to various embodiments of the present invention make use of wireless control and wireless power in lighting devices to provide advantages in ease of installation, in the ability to install lighting in locations independent of a connection to wired power, in cost savings, in energy efficiency and in the reduction of energy consumption at times of peak demand through controls and power management and in safety, security, and convenience for the end user.

[0007] Wireless control, as in relation to lighting facilities of the present invention, may be defined as any control aspect that provides a controlling function to the lighting facility without the use of a wired connection, such as a wired control interface, wired power control, and the like. Control aspects may include, but are not limited to, a wireless remote control interface (e.g. RF remote control), a wireless power controller (e.g. control of the source of power to the LEDs, such as including integrated energy storage device(s) and AC power), a wireless control input (e.g. an environmental sensor input), internal programmed control (e.g. internal program store controlled through a state machine or processor), and the like. In embodiments, cost savings and power management may be implemented through wireless control. In embodiments,

wireless control may enable a distributed intelligence architecture where the LED lighting facility may operate in an autonomous manner in response to its wireless control inputs or internal program. In embodiment, wireless control may be used in conjunction with wireless power to allow operation of the lighting facility completely independent of the power grid.

[0008] In some embodiments, wireless control allows the installation of the device in any indoor or outdoor location where light may be desired without the need for a wired connection to control it. In some embodiments, wireless control is used in a lighting device with a wired connection but allows an alternate method of control of the light rather than by its wired connection. In some embodiments, a lighting circuit may have multiple lights on the circuit, but wireless control built into the lights on that lighting circuit may allow them to be independently controlled.

[0009] Power sources that can be used stand-alone as described herein (i.e. not connected to a traditional AC power source) are defined as wireless power sources. A wireless power source may be an energy storage device such as a non-rechargeable battery, a rechargeable battery, a capacitor, a fuel cell, and the like. A wireless power source may be derived from an energy harvesting method such as using solar cells, capturing radiofrequency energy, converting kinetic energy to electrical energy (including converting motion or tension into electrical energy), converting thermal energy into electrical energy, converting wind energy into electrical energy, and the like. Multiple wireless power sources may be used together in some embodiments. For example, a light bulb with an integrated rechargeable battery may also contain solar cells on its housing and the ability to charge the integrated battery accordingly.

[0010] In some embodiments, a wireless power source integrated into the lighting device allows the installation of the lighting device in any indoor or outdoor location where light may be desired without the need for a wired connection to an AC power source. In other embodiments there is a wired connection to an AC power source, but the wireless power source is used when advantageous, for example as a backup power source in an emergency or as an alternative power source to provide energy efficiency or cost savings.

[0011] The embodiments described for the present invention may use wireless control and wireless power in conjunction with LEDs as a light source for illumination. In one embodiment, a power uninterruptable LED light with sensor-based control for transferring to internal power in the event of an AC power disruption is described. The power uninterruptable LED light may be designed in a housing type of a bulb, tube, lamp, fixture, retrofit fixture, and the like. The housing may contain internal wireless power in the form of an internal power source such as a rechargeable battery that can be used to power the light source upon a detected AC power disruption. For example, the power uninterruptable LED light may be a standard size light bulb that when plugged into a standard light socket acts normally as a light bulb, but in the event of an AC power disruption may use the internal power source to continue emitting light through the power disruption. Several forms of wireless control can be used with the disclosed invention including AC power sensing, impedance sensing of the lighting circuit to determine the on/off state of controlling switches, remote control in the form of a radio frequency receiver, sensors built into the housing such as a motion sensor or light sensor, and the like.

[0012] Another embodiment of the invention is directed to an externally controllable LED light in a housing type of a bulb, tube, lamp, fixture, retrofit fixture, and the like, that may receive commands from a power company or lighting control software to control the use of the wireless power source. For example, a load control switch or demand response mechanism reducing light intensity may be designed to control lighting to reduce power consumption during periods of peak usage of electricity. In the instance of reducing the intensity of the lights, the present invention instead may move the power switched off or reduced by the power company or lighting control software onto battery power, thus enabling the light to stay at the same intensity level while still reducing the power consumed from the AC power source. The source of the load control signal is external to the externally controllable LED light itself. This is "grid shifting" or storing energy from the grid to the integrated power source at one time and using that stored energy at another time when it is advantageous. This allows moving on and off of the AC power source using the integrated power source as an alternate power source and the control of that and other functions with external signals. In some embodiments, AC power and the integrated power source may be used simultaneously where the load is shared by the power sources. In such a case, the load on the AC power source may be reduced by some amount by transferring some amount of load to the integrated power source. The externally controllable LED light may also contain any form of wireless control which can also be controlled by the power company or lighting control software to enable, disable or set the functionality of the wireless control mechanism.

[0013] Another embodiment of the invention is directed to a wirelessly controlled LED light bulb containing an integrated power source where the wireless control is through built in sensors, program based intelligence, remote control based on a communication interface wirelessly, over the wire, and the like. With wireless control and wireless power integrated, the wirelessly controlled LED light bulb may operate autonomously in response to the input devices, internal timers, internal clock and/or internal program. It may have the ability to use the integrated power source autonomously for grid shifting, load shedding, independent control of the light sources on a single lighting circuit, backup power, energy harvesting when an energy harvesting power source is integrated in the bulb, or any application-specific function in which an integrated power source may be advantageous.

[0014] Another embodiment of the invention is directed to a wirelessly networked LED light with sensor-based control. The wirelessly networked LED light with sensor-based control may be designed in a housing type of a bulb, tube, lamp, fixture, retrofit fixture, battery powered fixture, and the like. Building a networking capability into a removable and replaceable wirelessly networked LED light bulb creates the ability to plug bulbs in such that they become part of the network without running new wiring (i.e. a plug and play lighting network). This is enabled by building the ability to receive control and programming over a network as well as forward or route traffic to other wirelessly networked LED lights that are part of the network into the lights themselves. If the wirelessly networked LED light is a removable device such as a bulb, tube or lamp, it may be installed as a light source and a node in the lighting network by installing it in a standard socket. Networked bulbs, tubes, lamps, fixtures, retrofit fixtures and battery powered fixtures may operate in a coordinated fashion, where one or more light sources are

operating with battery only, battery and AC or AC only power sources along with any control source within the group. In some embodiments, the source of the control for one or more lights in the group may be one of the lights in the group in response to a control input that light received. In addition to coordinating operation, the network may be used for communication purposes such that an extensible lighting network can be installed by installing bulbs, tubes, lamps and battery power fixtures in existing locations that do not require an electrician for new wiring or special hardware other than what is contained with the wirelessly networked LED light itself.

[0015] Another embodiment of the invention is directed to a centralized power outage system bridged to a networked lighting system. The centralized power outage control may come in the form of a module that detects a disruption in the AC power source and transmits to a system of bulbs, tubes, lamps, fixtures, retrofit fixtures, battery powered fixtures, and the like, to turn on, switch to backup power or change their mode of operation in some manner in response to the detected disruption in power. The power outage module may be connected to an emergency lighting circuit to transmit control to a networked lighting system when the emergency lighting circuit attempts to turn on emergency lighting. Due to its integrated power source, a wirelessly controlled and/or wirelessly powered LED light may continue to operate in an emergency situation as controlled by a power outage control module.

[0016] Another embodiment of the invention is directed to a sensor-based wirelessly controlled LED light. The sensor-based wirelessly controlled LED light may be designed in a housing type of a bulb, tube, lamp, fixture, retrofit fixture, and the like. In the embodiment, the sensor-based wirelessly controlled LED light is AC powered and contains input devices and the ability to autonomously respond to the input devices. For example, a daylight harvesting LED light bulb may adjust the light intensity based on the ambient light level detected by a light sensor built into the bulb. In an alternate version, the light sensor is built into a remote transmitter that may transmit the ambient light reading directly to one or more sensor-based wirelessly controlled LED lights that can then adjust the light intensity of the LED light source based on a configured net light that needs to be detected at the light sensor. The sensor-based wirelessly controlled LED light may have the ability to learn from the input devices. For example, a sensor-based wirelessly controlled LED light with a motion sensor and real time clock built into the device may learn that motion detections will be high at a certain time of the day. An internal program may schedule the light to turn on automatically at that time of day rather than use the motion sensor. The internal program may dynamically change the schedule to move the time the light turns on automatically to earlier or later times based on the motion detection input.

[0017] One advantage of the present invention is the ability to build intelligent lighting systems where wireless control and wireless power along with the ability to take advantage of the additional functionality is built into the light itself. One advantage of the present invention is the ability to provide battery back-up power within an LED bulb or tube that can fit into conventional AC powered sockets. In some embodiments, these lights are able to provide light in the event of power outage, and in other embodiments these lights may be used to reduce demand on the power grid by switching to battery power at peak times, then recharging off peak. One advantage of the present invention is the ability to create

programmable light bulbs, tubes or lamps with integrated sensors. These intelligent lights may contain integrated controls that turn on, off, or change light intensity based on a programmable schedule, the detection of sensor inputs, or a change in lighting conditions. One advantage of the present invention is the ability to communicate controls to and between these LED lighting facilities. In some embodiments, intelligent lights may contain wireless transmitters and receivers allowing them to coordinate functions within groups of light bulbs or allowing them to receive control and programming over a network as well as forward or route traffic to other light bulbs that are part of the network. Thus, for example, a removable light bulb may also act as a node in a network of light bulbs providing the ability to deploy a lighting installation and a network to control the lighting installation by plugging light bulbs into sockets.

[0018] It should be appreciated that combinations of the foregoing concepts and additional concepts discussed in greater detail below are contemplated as being part of the inventive subject matter disclosed herein. In particular, all combinations of claimed subject matter appearing at the end of this disclosure, or elsewhere herein, are contemplated as being part of the inventive subject matter.

[0019] These and other systems, methods, objects, features, and advantages of the present invention will be apparent to those skilled in the art from the following detailed description of the preferred embodiment and the drawings. All documents mentioned herein are hereby incorporated in their entirety by reference.

BRIEF DESCRIPTION OF THE FIGURES

[0020] The invention and the following detailed description of certain embodiments thereof may be understood by reference to the following figures:

[0021] FIG. 1 shows a perspective view of one embodiment of a wireless lighting module.

[0022] FIG. 2 shows a simplified schematic view of one embodiment of a wireless lighting module.

[0023] FIG. 3 shows a perspective view of one embodiment of a remote control for a wireless light.

[0024] FIG. 4 shows a simplified schematic view of one embodiment of a remote control for a wireless light.

[0025] FIG. 5 shows a simplified schematic drawing of an RF communication system for controlling a light.

[0026] FIG. 6 shows a simplified schematic drawing of an alternative embodiment of a wireless lighting module.

[0027] FIG. 7 shows a block diagram of a system that provides illumination with a wireless light.

[0028] FIG. 8 shows a methodology that facilitates selectively emitting light in accordance with a wireless input.

[0029] FIG. 9 shows a methodology that facilitates selectively emitting light based upon input from a sensor.

[0030] FIG. 10 shows a block diagram of an example wireless lighting system.

[0031] FIG. 11 shows a block diagram of an example wireless lighting system that utilizes RF signaling to control lighting.

[0032] FIG. 12 shows another block diagram of an example system that provides wireless lighting.

[0033] FIG. 13 shows a block diagram of an example system that provides illumination with a wireless light.

[0034] FIG. 14 shows a block diagram of an example system that recharges a power source integrated within a wireless light bulb.

[0035] FIG. 15 shows a block diagram of an example system that coordinates operation of a set of wireless light bulbs.

[0036] FIG. 16 shows a methodology that facilitates selectively emitting light in accordance with a wireless input.

[0037] FIG. 17 shows a methodology that facilitates selectively emitting light based upon input from a sensor.

[0038] FIG. 18 shows an example networking environment, wherein the novel aspects of the claimed subject matter can be employed.

[0039] FIG. 19 shows an example operating environment that can be employed in accordance with the claimed subject matter.

[0040] FIG. 20 shows a perspective view of an embodiment of a motion wireless light bulb.

[0041] FIG. 21 shows a perspective view of the recessed fixture version of a wireless light bulb.

[0042] FIG. 22 shows a perspective view of an embodiment of a battery embedded solar recharged PAR30 wireless light bulb.

[0043] FIG. 23 shows a block diagram of an example system that uses an AC power and embedded battery power with an intelligent, programmable controller.

[0044] FIG. 24 shows a block diagram of an example system that uses an AC power and embedded battery power with an intelligent, programmable controller and a grid tie inverter to deliver power to the grid.

[0045] FIG. 25 shows a block diagram of an example system that uses an electronic ballast and embedded battery power in a compact fluorescent lamp with an intelligent, programmable controller.

[0046] FIG. 26 shows a perspective view of an embodiment of an AC powered battery embedded PAR30 wireless light bulb.

[0047] FIG. 27 shows a block diagram of example architectures for an on line wireless light bulb.

[0048] FIG. 28 shows a block diagram showing an example AC powered super capacitor embedded wireless light bulb system.

[0049] FIG. 29 shows a perspective view of the recessed fixture version of a wireless light bulb with an external power supply with battery.

[0050] FIG. 30 shows a perspective view of the stair light embodiment of a wireless lighting module.

[0051] FIG. 31 shows a perspective view of the sensor light embodiment of a wireless lighting module.

[0052] FIG. 32 shows a use scenario of the stair light as a path light.

[0053] FIG. 33 shows a kit description of a fall prevention kit.

[0054] FIG. 34 shows a use scenario of the stair light on a deck near the stair to the deck.

[0055] FIG. 35 shows a use scenario of three stair lights mounted on a stair way and an RF remote control.

[0056] FIG. 36 shows a perspective view of the RF Spotlight embodiment of a wireless lighting module.

[0057] FIG. 37 shows a perspective view of the RF Ceiling Light embodiment of a wireless lighting module.

[0058] FIG. 38 shows an embodiment for an uninterruptible lighting facility with control, remote control, AC power, and battery.

[0059] FIG. 39 shows an embodiment for an uninterruptible lighting facility with control, AC power, and removable battery.

[0060] FIG. 40 shows an embodiment for an uninterruptible lighting facility with input device, impedance, control, AC power, and battery.

[0061] FIG. 41 shows an embodiment for an uninterruptible lighting facility with a sensor, control, AC power, and removable battery.

[0062] FIG. 42 shows an embodiment for an uninterruptible lighting facility with sensor, control, AC power, and rechargeable battery.

[0063] FIG. 43 shows an embodiment for an uninterruptible lighting facility with AC power and rechargeable battery.

[0064] FIG. 44 shows an embodiment for an externally controllable light with external control with power shifting, internal control, AC power, and battery.

[0065] FIG. 45 shows an embodiment for an externally controllable light with external control, internal control, impedance sense, AC power, and battery.

[0066] FIG. 46 shows an embodiment for an externally controllable light with external control, internal control, sensor, AC power, and battery.

[0067] FIG. 47 shows an embodiment for an externally controllable light with internal load sharing control, AC power, and battery.

[0068] FIG. 48 shows an embodiment for an externally controllable light with external control, internal control, sensor, AC power, battery, and network interface.

[0069] FIG. 49 shows an embodiment for remote control wireless light with daylight harvesting, control, and battery.

[0070] FIG. 50 shows an embodiment for remote control wireless light with sensor, programmable control, and battery.

[0071] FIG. 51 shows an embodiment for remote control wireless light with impedance sensing, control, programmability, and battery.

[0072] FIG. 52 shows an embodiment for remote control wireless light with power management control, programmability, remote, and battery.

[0073] FIG. 53 shows an embodiment for remote control wireless light with energy harvesting, battery, and control.

[0074] FIG. 54 shows an embodiment for remote control wireless light with power management control, programmability with learned behavior, remote, and battery.

[0075] FIG. 55 shows an embodiment for remote control wireless light with motion sensing, AC power, and battery.

[0076] FIG. 56 shows an embodiment for remote control wireless light with power management control, programmability with learned behavior, remote, and battery.

[0077] FIG. 57 shows an embodiment for a networked light with sensor input.

[0078] FIG. 58 shows an embodiment for a networked light with sensor input and impedance sensing.

[0079] FIG. 59 shows an embodiment for a networked light with sensor input and external control source.

[0080] FIG. 60 shows an embodiment for a networked light with battery and internal control source.

[0081] FIG. 61 shows an embodiment for a networked light with wireless power, wireless control, and power management.

[0082] FIG. 62 shows an embodiment for a centralized power outage light with sensor, outage input, and control.

[0083] FIG. 63 shows an embodiment for a centralized power outage light with impedance sensing, outage input, and control.

[0084] FIG. 64 shows an embodiment for a centralized power outage light with sensor, outage input, control, and connection to emergency lighting system.

[0085] FIG. 65 shows an embodiment for a sensor-based wirelessly controlled light with wireless control, remote sensor, and power management.

[0086] FIG. 66 shows an embodiment for a sensor-based wirelessly controlled light with daylight harvesting and power management.

[0087] FIG. 67 shows an embodiment for a sensor-based wirelessly controlled light with AC power and programmability through switch settings.

[0088] While the invention has been described in connection with certain preferred embodiments, other embodiments would be understood by one of ordinary skill in the art and are encompassed herein.

[0089] All documents referenced herein are hereby incorporated by reference.

DETAILED DESCRIPTION

[0090] The claimed subject matter is described with reference to the drawings, wherein like reference numerals are used to refer to like elements throughout. In the following description, for purposes of explanation, numerous specific details are set forth in order to provide a thorough understanding of the subject innovation. It may be evident, however, that the claimed subject matter may be practiced without these specific details. In other instances, well-known structures and devices are shown in block diagram form in order to facilitate describing the subject innovation. Moreover, it is to be appreciated that the drawings may not be to scale.

[0091] As utilized herein, terms “component,” “system,” and the like are intended to refer to a computer-related entity, either hardware, software (e.g., in execution), and/or firmware. For example, a component can be a process running on a processor, a processor, an object, an executable, a program, and/or a computer. By way of illustration, both an application running on a server and the server can be a component. One or more components can reside within a process and a component can be localized on one computer and/or distributed between two or more computers.

[0092] Furthermore, the claimed subject matter may be implemented as a method, apparatus, or article of manufacture using standard programming and/or engineering techniques to produce software, firmware, hardware, or any combination thereof to control a computer to implement the disclosed subject matter. The term “article of manufacture” as used herein is intended to encompass a computer program accessible from any computer-readable device, carrier, or media. For example, computer readable media can include but are not limited to magnetic storage devices (e.g., hard disk, floppy disk, magnetic strips), optical disks (e.g., compact disk (CD), digital versatile disk (DVD)), smart cards, and flash memory devices (e.g., card, stick, key drive). Additionally it should be appreciated that a carrier wave can be employed to carry computer-readable electronic data such as those used in transmitting and receiving electronic mail or in accessing a network such as the Internet or a local area network (LAN). Of course, those skilled in the art will recognize many modifications may be made to this configuration without departing from the scope or spirit of the claimed subject matter. Moreover, the word “exemplary” is used herein to mean serving as an example, instance, or illustration. Any

aspect or design described herein as “exemplary” is not necessarily to be construed as preferred or advantageous over other aspects or designs.

[0093] The claimed subject matter is directed to wireless LED lighting. With reference to FIG. 1, illustrated is a perspective view of one embodiment of a wireless lighting module 100. In the illustrated embodiment, the wireless lighting module 100 includes a housing 110 and a plurality of LEDs 120. In one embodiment, the wireless lighting module 100 includes 16 LEDs. In alternative embodiments, the lighting module may include more LEDs 120 to provide greater illumination or fewer LEDs 120 to use less power. It is to be appreciated that the wireless lighting module 100 can include any number of LEDs 120, and the LEDs 120 can be positioned at substantially any locations with respect to one another as well as in comparison to the housing 110.

[0094] In one embodiment, the housing 110 is constructed of plastic. Alternatively, the housing 110 can be constructed of metal or any other known material. In one embodiment (not shown), the housing 110 includes a mounting device for mounting the wireless lighting module 100 to a wall, ceiling, cabinet, or other surface. Exemplary mounting devices include screws, nails, adhesive, suction cups, magnets, VEL-CRO, fixing posts, flanged heads of fasteners, and other known mounting devices. In this embodiment, the housing 110 is configured to be mounted under a cabinet or desk, on a mailbox, or on a wall or ceiling of a room, closet, attic, basement, garage, storage area, shed, wall unit, hallway, stairway, emergency exit path, or cabinet, or in any other indoor or outdoor location where light may be desired. In one embodiment, one wireless lighting module (e.g., the wireless lighting module 100) illuminates an area of 20 square feet. It is to be appreciated that the housing 110 can be any size and/or shape and is not limited to the depicted illustration (e.g., the housing 110 can be dome shaped, pyramid shaped, cylindrical.). According to another example, the housing 110 can form a rope light.

[0095] With continued reference to FIG. 1, the LEDs 120 of the wireless lighting module 100 are arranged in an array to disperse light over a desired area. In alternative embodiments (not shown), one or more LEDs 120 are arranged in a spot-light to focus light over a desired area. In one embodiment, the LEDs 120 are white. In an alternative embodiment, the LEDs 120 are colored. In such an embodiment, all of the LEDs in the wireless lighting module 100 may be of the same or different colors. When the LEDs in the wireless lighting module 100 are of different colors, the relative intensity of the LEDs may be controlled (e.g. via pulse-width modulation, constant current control, variable current control, or the like) to produce illumination in a variety of mixed colors. For example, the LEDs may include red, green, and blue LEDs and the mixed colors may include a substantial number of colors represented in an RGB color wheel of a certain resolution (e.g. 8-bit, 16-bit, 24-bit, and so on). Regardless of whether the LEDs are of different colors, controlling the intensity of one or more LEDs via pulse-width modulation may provide power savings, dimming, and so on.

[0096] In the illustrated embodiment, the wireless lighting module 100 further includes a light-transmitting cover 130. In one embodiment, the light-transmitting cover 130 is transparent. Alternatively, the cover may be colored or frosted. In one embodiment, the light-transmitting cover 130 is smooth. In alternative embodiments, the cover may be etched or otherwise textured. The light-transmitting cover 130 may have any

desired shape. In an alternative embodiment (not shown), the module does not include a light-transmitting cover. In another embodiment, the wireless lighting module includes a filter (not shown).

[0097] In other embodiments, an optical lens or lenses or reflectors to direct the light, reflect the light or change the viewing angle of the LEDs. The housing of the unit may include any number of optical elements. The optical elements may serve to focus, diffuse, filter, collimate, or otherwise affect light produced by the LEDs. In embodiments, the optical elements may include one or more lenses, reflectors, optical filters, apertures, and so on. The lenses may be fixed, a multiple lens array, adjustable, and so on. The lenses or reflectors may be manually adjustable, motorized with direct control with switches on the unit for adjusting the direction or characteristics of the light source, motorized with a remote control for adjusting the direction or characteristics of the light source through RF or IR control or it may detect motion and automatically adjust the lenses or reflectors to aim the light in the direction of the motion either to illuminate an area or as a deterrent for security reasons or as a deterrent for animals.

[0098] FIG. 2 shows a simplified top plan view of the wireless lighting module 100, with the housing 110 and light-transmitting cover 130 removed. As shown in the illustrated embodiment, the wireless lighting module 100 includes a power source, such as a battery 210. In alternative embodiments, the power source may be a solar cell. In one known embodiment, three “AAA” size alkaline batteries are used as a power source. In an alternative embodiment, three “C” size alkaline batteries are used. It should be understood that any number of known batteries may be used, including without limitation all known alkaline and nickel-cadmium batteries, depending on size and power requirements. According to another example, the power source can be any number and type of rechargeable batteries and/or non-rechargeable batteries. Pursuant to a further illustration, the power source can be a combination of a solar cell and one or more batteries (e.g., rechargeable, non-rechargeable.). Thus, for instance, a battery can supplement the power supplied by the solar cell (or vice versa) and/or the solar cell can recharge a battery. In some embodiments of the foregoing arrangement, a solar cell may be diode or-ed with a battery and the battery may be non-rechargeable. In alternate embodiments the power source may include a fuel cell, such as and without limitation a hydrogen fuel cell, a reformed methanol fuel cell, or the like. In alternate embodiments, the power source may include a capacitor, array of capacitors, super capacitors to store energy to be used as a power source similar to a battery, and the like.

[0099] In some embodiments, the power source may employ any and all forms of energy harvesting. Energy harvest may, without limitation, include capturing radiofrequency energy, converting kinetic energy to electrical energy (including converting motion or tension into electrical energy), converting thermal energy into electrical energy, converting wind energy into electrical energy, and so on. In some embodiments, energy harvesting may include collecting light from other light sources and converting that light into electrical energy. It will be understood that a variety of systems and methods that harvest energy are possible. In alternate embodiments, the power source may be through wireless power transmission where a method of wireless power transmission may act as the power source or in combination with

the other power sources mentioned herein (e.g. rechargeable batteries, capacitors, and the like) to provide power to the module.

[0100] Power sources that can be used stand alone as described herein (i.e. not connected to a traditional AC power source) are defined as wireless power. A wireless power source allows the installation of the wireless lighting module **100** in any indoor or outdoor location where light may be desired without the need for a wired connection to an AC power source.

[0101] As shown, the battery **210** is electrically connected to the LEDs **120** to provide power for the light output. The battery **210** is also connected to a receiver **220** configured to receive a data stream. In one embodiment, the receiver **220** is configured to receive a data stream in the form of RF signals and is further configured to output data to logic **230**. In one embodiment, the receiver **220** is configured to receive data at up to 100 kbps and has a receive sensitivity of as little as -115 dBm. In an alternative embodiment, the receiver **220** is configured to receive IR signals.

[0102] In one embodiment, the receiver **220** includes an integrated processor (not shown). The integrated processor of the receiver **220** is separate from the logic **230** of the wireless lighting module **100**. The integrated processor is configured to convert an RF or IR data stream to digital data output. The integrated processor may be an integrated circuit, a micro-processor, or other known processor. For example, the receiver **220** may be a commercially available MAXIM MAX1470 RF Integrated Circuit 300-450 MHz ASK Super-heterodyne receiver.

[0103] With continued reference to FIG. 2, the battery **210** is also connected to the logic **230**. The logic **230** is configured to monitor data received by the receiver **220**. In one embodiment, described above, the receiver **220** outputs digital data. In an alternative embodiment, the receiver **220** outputs analog data and the logic **230** is configured to convert the analog data to digital data. The logic **230** is configured to detect specific sequences of data, such as commands and channel data, as will be described in more detail below. In response to the sequences of data, the logic **230** may control the LEDs **120** as described herein and elsewhere. In some embodiments, the sequences of data may originate from or relate to the output of a sensor. The logic **230** may be an integrated circuit, a micro-processor, or any known type of processor. For example, the logic **230** may be a commercially available FREESCALE Semiconductor MC68HC908QT microcontroller. Embodiments of the logic **230** may be programmable so that control of the LEDs **120**, responses to sequences of data, and other programmable functions may be field programmable, end-user programmable, added and removed after market, added and removed by an OEM, and so on.

[0104] In one embodiment, the logic **230** employs a power sequencing algorithm to conserve power. In this embodiment, the logic **230** stays in a “hibernation” mode to conserve power. The logic **230** is activated a few times per second to monitor the receiver **220**. If the logic **230** detects output from the receiver **220**, the logic **230** reads the data and executes commands according to a protocol described below. If the logic **230** does not detect output from the receiver **220**, it returns to hibernation mode.

[0105] The logic **230** is also in electric communication with the LEDs **120**. The logic **230** maintains the on/off state of the LEDs **120**. Additionally, the logic **230** may be configured to control the brightness of the LEDs **120**. In one embodiment,

the logic **230** is configured to turn off the LEDs **120** after a predetermined amount of time to conserve power. The logic **230** is also configured to control pulse width modulation to extend battery life.

[0106] In one embodiment, the LEDs **120** are color changing LEDs and the logic **230** is configured to control the color emitted by the LEDs **120**. In one embodiment (not shown), when more than one wireless lighting module is employed, the modules may be synchronized such that the logic of each module changes the light color at the same time or according to a user preference.

[0107] FIG. 3 illustrates a perspective view of one embodiment of a remote control **300** for a wireless lighting module (e.g., the wireless lighting module **100** of FIG. 1). The remote control **300** includes a housing **310**. In one embodiment (not shown), the housing **310** is configured to be attached to a keychain. In another embodiment (not shown), the housing **310** is configured to be mounted to a wall.

[0108] In the illustrated embodiment, the remote control **300** includes a button **320** configured to receive user input. Here, the button **320** receives an on/off toggle command. In an alternative embodiment (not shown), the remote control **300** includes a plurality of buttons. The additional buttons may be configured to receive a separate “on” command and “off” command. The additional buttons may also be configured to receive a “dim” or “brightness” command or a color changing command. In another alternative embodiment (not shown), the remote control **300** further includes a DIP switch for receiving a channel number. In other alternative embodiments (not shown), the remote control **300** employs dials, toggle switches, levers, knobs, buttons, or any other appropriate controls to receive user input. According to another example, the remote control **300** can utilize a touch panel for obtaining user input.

[0109] The remote control **300** further includes a transmitter **330** configured to transmit a signal. In one embodiment, the transmitter **330** is an RF transmitter. In an alternative embodiment, the transmitter **330** is an IR transmitter. In one embodiment, the transmitter **330** includes an integrated processor (not shown), such as a MAXIM MAX 1472 RF Integrated Circuit 300-450 MHz ASK transmitter and is configured to transmit data at up to 100 kbps. According to another illustration, the remote control **300** can include a transceiver that can receive data from a wireless lighting module as well as transmit data to the wireless lighting module. In some embodiments, the remote control **300** may transmit at a user-selected radio frequency or at a predetermined radio frequency with any and all types of encoding or modulation. It will be understood that the radio frequency may include UHF, VHF, ISM band, and so on. Furthermore, it will be understood that a variety of types of encoding or modulation are possible. For example and without limitation, the remote control **300** may function in accordance with WIFI, ZIGBEE, BLUETOOTH, or the like. For another example and without limitation, the remote control **300** may function substantially as an RFID tag. In embodiments, the remote control **300** may be handheld, wall mounted (e.g. as a switch or the like that is battery powered or AC powered from a switch plate), and so on.

[0110] FIG. 4 illustrates a simplified top plan view of a remote control **300** with a housing **310** removed. The remote control **300** includes a power source, such as a battery **410**. In one embodiment, the battery **410** is a CR2032 coin cell battery. In alternative embodiments, any number of any known

type of battery may be used. The battery is electrically connected to and supplies power to the transmitter **330**.

[0111] In the illustrated embodiment, the battery **410** is also connected to and supplies power to logic **420**. The logic **420** is configured to monitor a switch (not shown) connected to the button **320**. The logic **420** is further configured to build and send a control message to the transmitter **330**. In one embodiment, the logic **420** sends a digital control message to the transmitter **330**. An integrated circuit (not shown) of the transmitter **330** then converts the digital control message to an analog control message for transmission as an RF signal. In an alternative embodiment, the transmitter **330** is configured to transmit a digital RF signal. In another alternative embodiment, the logic **420** sends an analog control message to the transmitter **330**.

[0112] In one embodiment, the logic **420** is configured to recognize an on/off toggle command. The logic **420** receives the on/off toggle command when a user presses the button **320**. In another embodiment (not shown), the logic **420** is configured to recognize a separate “on” command and “off” command. In yet another embodiment (not shown), the logic **420** is configured to recognize a “dim” or “brightness” command or a “color change” command. When the logic **420** receives a command, the logic **420** outputs a control message containing the command and a channel number. In one embodiment, the logic **420** receives the channel number from a user input device. In an alternative embodiment, the logic **420** looks up the channel number in a memory (not shown). In another alternative embodiment, the processor generates a random number to use as a channel number.

[0113] FIG. **5** is a schematic drawing of one embodiment of a remote control **500** in communication with a wireless lighting module **510**. In the illustrated embodiment, the user selects a channel number on the remote control **500** through a channel number input **520**. Exemplary channel number inputs **520** include DIP switches, buttons, dials, knobs, a keypad, an LED touch-screen, or any other known input device. In an alternative embodiment, a user may select more than one channel number to communicate with a plurality of wireless lighting modules. In other alternative embodiments, the channel number may be preprogrammed, randomly generated, or previously stored in a memory. The user then enters a command through a command input **530**. Exemplary command inputs **530** include buttons, switches, dials, knobs, a keypad, an LED touch-screen, or any other known input device. The command may be an “on/off” toggle command, an “on” command, an “off” command, a “dim” command, a “brightness” command, a “color change” command, or a timer command.

[0114] After a user inputs a command through the command input **530**, logic **540** encodes the channel number and the command and instructs an RF transmitter **550** to transmit an RF signal that includes the encoded channel number and command. In one embodiment, the RF transmitter **550** transmits RF signals at a frequency of 433 MHz. In alternative embodiments, the RF transmitter may transmit at a user selected-frequency or at any predetermined frequency.

[0115] In one embodiment, the RF signal is transmitted once. In an alternative embodiment, the RF signal is transmitted a predetermined number of times, or for a predetermined time period. If more than one RF signal is transmitted, each transmission may be separated by a predetermined interval.

[0116] With continued reference to FIG. **5**, the wireless lighting module **510** includes an RF receiver **560** that moni-

tors for RF signals at a predetermined frequency. In one embodiment, the RF receiver **560** periodically monitors for RF signals. In an alternative embodiment, the RF receiver **560** continuously monitors for RF signals. When an RF signal is received, the signal is transmitted to logic **570**, where the signal is decoded. In one embodiment, the logic **570** reads the decoded channel number and compares the decoded channel number to a module channel number. The module channel number may be selected by a user via a channel input device (not shown), or it may be pre-programmed.

[0117] If the decoded channel number matches the module channel number, the logic **570** processes the decoded command. For example, if the command is an on/off toggle command, the logic **570** will instruct an LED controller **580** to toggle a plurality of LEDs **590**. If the command is an “on” command, the logic **570** will determine if the plurality of LEDs **590** are in an “on” state. If the LEDs **590** are not in an “on” state, the logic **570** will instruct the LED controller **580** to activate the plurality of LEDs **590**.

[0118] In an alternative embodiment (not shown), the RF transmitter **550** and the RF receiver **560** are replaced with RF transceivers, thus allowing two-way communication. In this embodiment, the remote control is programmed to repeatedly transmit a command signal until a confirmation signal is received. Additionally, the lighting module is programmed to transmit a confirmation signal upon receipt of an RF signal, or upon a decoded channel number matching a module channel number. According to another example, RF transceivers can enable providing the remote control **500** with feedback concerning a state associated with the wireless lighting module **510** (e.g., whether the LEDs **590** are in an “on” state, an “off” state, a color of the LEDs **590**, an intensity of the LEDs **590**), battery life, and so forth. Moreover, RF transceivers can allow the wireless lighting module **510** to communicate with disparate wireless lighting module(s) (e.g., to repeat signals).

[0119] FIG. **6** is a schematic drawing of an alternative embodiment of a wireless lighting module **600**. In this embodiment, the wireless lighting module **600** is not controlled by a remote control, but is instead motion-controlled. The wireless lighting module **600** includes a passive infrared sensor **610** configured to detect motion. In one embodiment, the passive infrared sensor **610** has a range of approximately 5 feet and a viewing angle of 110 degrees. In alternative embodiments, the passive infrared sensor **610** may have a range and viewing angle of any known passive infrared sensor. In one alternative embodiment, the passive infrared sensor **610** is removably connected to the wireless lighting module **600** so that a user may connect any appropriate sensor. In some embodiments, the passive infrared sensor **610** may be replaced or enhanced by a radar sensor, an ultrasound sensor, or any and all other form of motion sensor.

[0120] In embodiments, any and all sensors may include a detection threshold or false detection rate that can be configured according to a user’s preference. For example and without limitation, a light sensor may be configured to detect when incoming light crosses a user-preferred intensity threshold. A variety of other such examples will be appreciated, all of which are within the scope of the present disclosure.

[0121] In embodiments, a Fresnel lens may enable motion detection. Some motion detectors may include a Fresnel lens that guides infrared light over a pyroelectric material in a substantially repeating pattern as a heat source (such as a person, vehicle, and so on) passes in front of the lens. In

embodiments, the Fresnel lens may be selected to provide a desired zone of coverage. It will be understood that a variety of embodiments of motion detectors including the Fresnel lens are possible.

[0122] With continued reference to FIG. 6, when the passive infrared sensor 610 detects motion, logic 620 determines if the motion is above a predetermined threshold. If the motion is above the predetermined threshold, the logic 620 instructs an LED controller 630 to turn on at least one LED 640. After the at least one LED 640 is turned on, the logic 620 starts a timer. The logic 620 will then instruct the LED controller 630 to turn off the at least one LED 640 if no motion is detected before the timer reaches a predetermined threshold.

[0123] The wireless lighting module 600 further includes at least one battery 650. The battery 650 supplies power to the logic 620, the LED controller 630, the at least one LED 640, and any other additional electric components. Further, the battery 650 can supply power to the passive infrared sensor 610. In one embodiment, the at least one battery 650 includes 3 “AAA” alkaline batteries. In an alternative embodiment, the at least one battery 650 includes 3 “C” alkaline batteries. In other embodiments, the at least one battery 650 may be any number of known batteries, including without limitation all known alkaline and nickel-cadmium batteries. It is to be appreciated that any number and type of rechargeable and/or non-rechargeable batteries can be utilized in connection with the claimed subject matter.

[0124] With reference to FIG. 7, illustrated is a block diagram of a system 700 that provides illumination with a wireless light. System 700 includes a wireless lighting module 702 that can further comprise an interface component 704, a battery 706, an LED controller 708, LEDs 710, and/or logic 712. The wireless lighting module 702 can be incorporated into a housing (not shown). It is contemplated that any size and/or shape housing can be employed with the wireless lighting module 702. According to another illustration, the housing can include at least a portion that is moveable (e.g., manually by a user, automatically with a motor or the like) to allow for directing emitted light. For example, a remote control can provide a signal to manipulate a moveable portion of the housing. Moreover, the housing can orient the LEDs 710 in substantially any manner to provide general lighting (e.g., illuminating an indoor or outdoor area), task lighting (e.g., reading), accent lighting, and so forth.

[0125] The interface component 704 can receive an input from a disparate device (e.g., the remote control 500 of FIG. 5, the passive infrared sensor 610 of FIG. 6). The interface component 704 can provide various adaptors, connectors, channels, communication paths, etc. to enable interaction with the disparate device. Pursuant to an illustration, the input can be wirelessly transmitted (e.g., via an RF signal, an IR signal) from the disparate device to the interface component 704; thus, the interface component 704 can be a receiver and/or a transceiver that obtains the wirelessly transferred signal. By way of example, an infrared sensor or motion sensor can monitor occupancy in an environment and, upon detecting presence within the monitored environment, the sensor can transmit a wireless input to the interface component 704. It is to be appreciated that any type of sensors can be utilized in connection with the claimed subject matter such as, but not limited to, infrared sensors, light sensors, proximity sensors, acoustic sensors, motion sensors, carbon monoxide and/or smoke detectors, thermal sensors, electromagnetic sensors, mechanical sensors, pressure sensors, chemical sen-

sors, and the like. According to another example, any type of remote control can wirelessly communicate with the interface component 704. For instance, the remote control can be a stand-alone remote control (e.g., the remote control 300 of FIG. 3) and/or incorporated into a disparate device (e.g., incorporated into a key fob, a programmable wireless transceiver integrated in an automobile.). Moreover, the remote control can be a personal computer, a cellular phone, a smart phone, a laptop, a handheld communication device, a handheld computing device, a global positioning system, a personal digital assistant (PDA), and/or any other suitable device; such devices can communicate directly with the interface component 704 and/or via a network (e.g., local area network (LAN), wide area network (WAN), cellular network). In accord with another example, radio frequency identification (RFID) can be utilized to provide the input to the interface component 704. As such, an RFID tag associated with a user can be detected when in range of the interface component 704, and lighting preferences of the particular user (e.g., retained in memory) can be effectuated in response to his or her detected presence.

[0126] Additionally or alternatively, the interface component 704 can be a sensor that can monitor a condition associated with the wireless lighting module 702 to generate the input. According to another example, the interface component 704 can be a connector, port, etc. that couples to such sensor.

[0127] Further, the interface component 704 can wirelessly transmit data (e.g., feedback, related to a current and/or anticipated future state) to a remote device and/or sensor. By way of another example, the interface component 704 can wirelessly communicate with an interface component of a disparate wireless lighting module to enable coordinated operation between more than one wireless lighting module. Following this example, an input can be retransmitted within a network of wireless lighting modules, where the network of lighting modules can be dispersed within a geographic area.

[0128] An interface component 704 integrated into the wireless lighting module 702 that allows it to be used stand alone, a sensor on the wireless lighting module 702 used for input or by a remote control that provides input wirelessly to the wireless lighting module 702, as described herein (i.e. not connected by wire to the wireless lighting module 702) is defined as wireless control. Wireless control allows the installation of the wireless lighting module 702 in any indoor or outdoor location where light may be desired without the need for a wired connection to control it.

[0129] The battery 706 can be any number and/or type of battery. For instance, the battery 706 can be a rechargeable battery. According to another example, the battery 706 can be a non-rechargeable battery. The battery 706 supplies power to the wireless lighting module 702 to enable installing, moving, replacing, etc. the wireless lighting module 702 at substantially any indoor or outdoor location while mitigating the need for expensive and time consuming wiring and/or utilization of aesthetically displeasing and potentially inconvenient cords commonly associated with conventional lighting.

[0130] The LED controller 708 can obtain instructions from the logic 712 to control operation of the LEDs 710. The LED controller 708, for example, can receive and effectuate instructions to switch one or more LEDs 710 on and/or off, change an intensity of illumination (e.g., brightness), switch a wavelength of light emitted from the LEDs 710 (e.g., to change light color), manipulate direction of illumination

(e.g., by moving, rotating, etc. one or more of the LEDs 710) and the like. Further, it is contemplated that any number, type, color, arrangement, etc. of LEDs 710 can be utilized with the wireless lighting module 702.

[0131] The logic 712 employs the input obtained by the interface component 704. The logic 712 can further include a state modification component 714, a timer component 716, an intensity regulation component 718, and/or a wavelength control component 720; however, it is to be appreciated that the logic 712 can include a subset of these components 714-720. The state modification component 714 utilizes the input obtained via the interface component 704 to generate an instruction to change a state of one or more of the LEDs 710. The state modification component 714 effectuates transitioning one or more LEDs 710 to an on state, an off state, etc. Further, the state modification component 714 can yield commands to strobe one or more LEDs 710 (e.g., periodically turning LED(s) 710 on and off with substantially any periodicity). According to an example, the state modification component 714 can decipher that a received input pertains to one or more of the LEDs 710. Moreover, the state modification component 714 can analyze the input to determine whether to instruct the LED controller 708 to change the state (e.g., compare an input from a sensor to a threshold, evaluate whether a condition has been met, based upon retrieved instructions corresponding to the input retained in memory.).

[0132] The timer component 716 can operate in conjunction with the state modification component 714. For instance, the timer component 716 can enable delaying state changes. Thus, turning the LEDs 710 on or off can be delayed for an amount of time by the timer component 716. Further, the amount of time for the delay can be predetermined, randomly selected, included with the input obtained by the interface component 704 (e.g., based on a number of times a button of a remote control is depressed), etc. According to another example, the timer component 716 can conserve battery life by enabling the state modification component 714 to switch the LEDs 710 to an off state at a particular time of day, after an elapsed amount of time subsequent to an input that turned the LEDs 710 to the on state, and so forth. Pursuant to another illustration, the timer component 716 can operate in conjunction with the intensity regulation component 718 and/or the wavelength control component 720 described below.

[0133] The intensity regulation component 718 can alter the intensity (e.g., brightness) of the LEDs 710 based upon the received input from the interface component 704. The intensity can be changed by the intensity regulation component 718 adjusting a proportion of LEDs 710 in an on state to LEDs 710 in an off state. Additionally or alternatively, the intensity regulation component 718 can control the intensity of light emitted by each of the LEDs 710. According to an example, the interface component 704 can obtain RFID related input that identifies the presence of a particular user, and this user can have lighting preferences stored in memory (not shown) associated with the wireless lighting module 702. Following this example, the particular user's preferences may indicate that she desires the LEDs 710 to be dimly lit, which can be effectuated by the intensity regulation component 718. Pursuant to another example, upon a smoke detector or carbon monoxide detector sensing smoke or carbon monoxide, respectively, the intensity regulation component 718 can increase the brightness of the illumination of the LEDs 710 to a highest level (e.g., while the state modification component 714 can strobe the LEDs 710, the wavelength control com-

ponent 720 can change the color). It is to be appreciated, however, that the claimed subject matter is not limited to the aforementioned examples.

[0134] The wavelength control component 720 can change the wavelength (e.g., color) of light generated by the LEDs 710 as a function of the input obtained by the interface component 704. For example, the LEDs 710 can be color changing LEDs, and the wavelength control component 720 can yield commands to adjust the color based upon the input obtained by the interface component 704. By way of another example, the LEDs 710 can include subsets of LEDs that yield differing colors, and the wavelength control component 720 can select which of the LEDs 710 to turn to the on state to yield the desired color.

[0135] FIGS. 8-9 illustrate methodologies in accordance with the claimed subject matter. For simplicity of explanation, the methodologies are depicted and described as a series of acts. It is to be understood and appreciated that the subject innovation is not limited by the acts illustrated and/or by the order of acts, for example acts can occur in various orders and/or concurrently, and with other acts not presented and described herein. Furthermore, not all illustrated acts may be required to implement the methodologies in accordance with the claimed subject matter. In addition, those skilled in the art will understand and appreciate that the methodologies could alternatively be represented as a series of interrelated states via a state diagram or events.

[0136] With reference to FIG. 8, illustrated is a methodology 800 that facilitates selectively emitting light in accordance with a wireless input. At 802, an input can be wirelessly received to control illumination of an array of LEDs powered by a battery. The input can be obtained from any type of source (e.g., remote control, disparate wireless lighting module, differing device, sensor). Moreover, the input can be provided from the source via an RF signal, an IR signal, and so forth. At 804, the input can be analyzed to determine whether to alter the illumination of the array of LEDs. For example, if the input provides a command to change the LEDs to an on state while the LEDs are currently in an off state, an instruction can be yielded to change the LEDs to the on state. According to another illustration, an amount of elapsed time can be tracked to identify when to effectuate a change in illumination. At 806, the illumination of the array of LEDs can be selectively adjusted based on the analyzed input. For example, LEDs can be transitioned to a differing state (e.g., turned on, turned off), intensity of LEDs can be altered, color emitted can be changed, and so forth.

[0137] Now referring to FIG. 9, illustrated is a methodology 900 that facilitates selectively emitting light based upon input from a sensor. At 902, a condition within an environment can be monitored. The condition can relate to motion, presence, pressure, temperature, location, sound, chemicals, light, or any condition that can be tracked with a sensor. At 904, a determination can be effectuated relating to whether to alter illumination of an array of LEDs powered by a battery based upon the monitored condition. For example, the determination can be made by comparing the monitored condition to a threshold. Moreover, a current state associated with the array of LEDs can be evaluated to determine whether a change in illumination should be effectuated. At 906, the illumination of the array of LEDs can be selectively altered based on the monitored condition. Thus, for example, LEDs can be transitioned to an on state when motion is detected. By

way of further illustration, the LEDs can be turned off when no motion is detected (e.g., for more than a predetermined amount of time).

[0138] Turning to FIG. 10, illustrated is a block diagram of a wireless lighting system 1000. The wireless lighting system 1000 includes a wireless light bulb 1002 that can mechanically couple to any type of fixture 1004. The fixture 1004 can be any size, shape, type, etc. of lighting fixture that can include any size, shape, type, etc. of socket with which the wireless light bulb 1002 can physically connect. Pursuant to an illustration, the fixture 1004 can be a free-standing or portable fixture, a recessed fixture, a surface mounted fixture, a sconce, a track light fixture, a pendant light fixture, an outdoor fixture (e.g., pole mounted, stanchion mounted, pathway lighting fixture), a lamp, and so forth. Thus, for example, the fixture 1004 can include an Edison socket and the wireless light bulb 1002 can comprise a screw base that can be physically coupled with the Edison socket of the fixture 1004. Further, the wireless light bulb 1002 can include any type, size, shape, etc. of fitting that can be compatible with a corresponding socket of the fixture 1004 (e.g., the fitting can include a screw base, a bayonet (push twist) base, wedge base, locking base, pin base). Moreover, it is contemplated that the wireless light bulb 1002 and the fixture 1004 can be electrically coupled when mechanically coupled and/or the wireless light bulb 1002 and the fixture 1004 can be mechanically coupled without electrical coupling.

[0139] The wireless light bulb 1002 can further include a light source 1006, a power source 1008, a control component 1010 and/or an input component 1012 (e.g., the light source 1006, the power source 1008, the control component 1010 and/or the input component 1012 can be integrated into a housing (not shown) of the wireless light bulb 1002). The light source 1006 can be any type, number, size, shape, etc. of lamp. For example, the light source 1006 can be one or more of incandescent, halogen, gas discharge, fluorescent, compact fluorescent, fiber optic, induction, light emitting diode (LED), etc. source(s). According to an illustration, the light source 1006 can include a plurality of LEDs that can be positioned at substantially any location with respect to one another. Following this illustration, the plurality of LEDs can be arranged in an array that can disperse light over a desired area; however, the claimed subject matter is not so limited. By way of another example, the wireless light bulb 1002 can include a housing (not shown) constructed of plastic, metal, and/or substantially any matter. For instance, at least a portion of the housing can enable light emitted by the light source 1006 to pass through it (e.g., at least a portion of the housing can be a light-transmitting material that can be transparent, translucent, frosted, colored). Additionally or alternatively, light generated by the light source 1006 need not traverse through the housing (e.g., the light source 1006 can be positioned upon the surface of the housing and/or the light need not propagate through a light-transmitting cover).

[0140] Further, the power source 1008 can be coupled to the light source 1006 (and/or disparate components of the wireless light bulb 1002) to supply power for operation of the light source 1006 (and/or the disparate components). For instance, the power source 1008 can provide direct current (DC) power to the light source 1006 (and/or disparate components of the wireless light bulb 1002). According to an example, the power source 1008 can be one or more batteries. For instance, the power source 1008 can be any number, size, and type of rechargeable (e.g., nickel-cadmium) and/or non-recharge-

able (e.g., alkaline) batteries. Pursuant to a further illustration, the power source 1008 can be a solar cell. Moreover, the power source 1008 can be a combination of a solar cell and one or more batteries. Thus, for instance, a battery can supplement power supplied by the solar cell (or vice versa) and/or the solar cell can recharge a battery. In accordance with a further illustration, the power source 1008 can wirelessly obtain power (e.g., to be utilized directly, employed to recharge batteries); for instance, power can be wirelessly delivered to the power source 1008 via collecting RF energy from the environment, electromagnetic induction, wave coupling, converting motion or heat to electrical energy, and the like.

[0141] In some embodiments, the power source 1008 may include alternating-current circuitry, including an AC/DC converter or a battery recharging circuit. The AC/DC converter may include a capacitor/diode bridge, a fly back converter, or a constant current circuit, and so on. It will be understood that a variety of AC/DC converters are possible.

[0142] By way of an example, the wireless light bulb 1002 can physically couple with the fixture 1004 to support the wireless light bulb 1002 in a particular position, yet electrical current need not flow between the fixture 1004 and the wireless light bulb 1002. Thus, the fixture 1004 can be installed at substantially any location without needing to supply power (e.g., via hard-wiring the fixture 1004); hence, the fixture 1004 can be physically placed, secured, mounted, installed, etc. in a locale without being hard-wired to a power source. In contrast, conventional techniques oftentimes employ hard-wired fixtures that can provide alternating current (AC) power to light bulbs coupled therewith.

[0143] According to another illustration, the fixture 1004 can provide AC power that can be leveraged by the wireless light bulb 1002 in addition to or instead of the power source 1008. For example, the wireless light bulb 1002 can lack the power source 1008 integrated therein, and the AC power from the fixture 1004 can power the wireless light bulb 1002. Additionally or alternatively, the wireless light bulb 1002 can include the power source 1008, and the power source 1008 can be a battery backup for the wireless light bulb 1002, for instance. Thus, upon detecting an AC power outage, the wireless light bulb 1002 can switch to utilizing the power source 1008 (e.g., one or more batteries) to supply power to the wireless light bulb 1002.

[0144] The wireless light bulb 1002 further includes the control component 1010 that manages operation of the light source 1006. For instance, the control component 1010 can switch the light source 1006 to an on state and/or an off state. Moreover, the control component 1010 can alter intensity, brightness, color (e.g., wavelength, frequency), etc. of the light yielded by the light source 1006.

[0145] The input component 1012 can obtain any type of input signal that can be leveraged by the control component 1010 to manipulate operation of the light source 1006. Thus, the input component 1012 can be a radio frequency (RF) receiver that can obtain an RF signal communicated from an RF transmitter (not shown) that can be utilized by the control component 1010 to control operation of the light source 1006. According to this example, the RF signal can be deciphered by the control component 1010 to effectuate switching the light source 1006 to an on or off state, changing a light color or a light intensity provided by the light source 1006, and the like. Additionally or alternatively, the input component 1012 can be one or more sensors that monitor a condition, and

monitored information yielded by such sensor(s) can be utilized to effectuate adjustments associated with the light source **1006**. According to another example, the input component **1012** can be a connector, port, etc. that couples to a disparate device, sensor, etc. to receive the input signal.

[0146] According to an example, the light source **1006**, the power source **1008**, the control component **1010** and the input component **1012** can be integrated into the housing of the wireless light bulb **1002**. Thus, the wireless light bulb **1002** can be mechanically coupled with the fixture **1004** and the wireless light bulb **1002** can be utilized regardless whether the fixture **1004** provides power (e.g., AC power and/or DC power). Moreover, conventional lighting systems can include a typical light bulb that can couple with an adapter that can sense motion, where the adapter can further couple to a socket of a light fixture, for example; however, such common sensors are oftentimes not integrated into the light bulb (e.g., due to a typical light bulb lifespan) and rather are stand alone devices. Pursuant to another illustration, the light source **1006**, the control component **1010** and the input component **1012** can be integrated into the housing of the wireless light bulb **1002**, and power (e.g., AC power) can be provided from the fixture **1004** when coupled thereto.

[0147] The housing of the wireless light bulb **1002** or the light source **1006** may include any number of optical elements. The optical elements may serve to focus, diffuse, filter, collimate, or otherwise affect light produced by the light source **1006**. In embodiments, the optical elements may include one or more lenses, reflectors, optical filters, apertures, and so on. The lenses may be fixed, a multiple lens array, adjustable, and so on. In some embodiments, the optical elements may be electrically adjustable. For example, an electric motor may be coupled to the aperture in order to adjust the aperture in response to a control signal (e.g. an RF signal, an IR signal, a signal generated by a logic circuit, and so on). For another example, the lens may be a liquid lens whose focus can be changed by direct application of an electrical potential. Generally, the direction, brightness, beam characteristics, or the like of the wireless light bulb **1002** may be variably affected by the optical elements that are responsive to the control signals. Numerous other such examples will be readily appreciated, and all such examples are within the scope of the present disclosure.

[0148] The following provides an illustration related to the wireless lighting system **1000**. For instance, any type of fixture **1004** can be obtained and installed at substantially any location without needing to wire the fixture **1004**. Rather, the fixture **1004** can be mounted, positioned, etc. and can thereafter be utilized to physically hold the wireless light bulb **1002**. Therefore, if a fixture is lacking in a particular location where substantial difficulty can be encountered in connection with wiring the fixture to provide power thereto if installed, the fixture can instead be physically placed, mounted, attached, etc. in the location without electrically wiring the fixture (and/or without electrically wiring a switch to control operation of the fixture). Moreover, the wireless light bulb **1002** can be mechanically coupled to the fixture **1004** (e.g., a fitting of the wireless light bulb **1002** can be attached to a socket of the fixture **1004**) and can leverage the power source **1008** (e.g., one or more batteries) and input component **1012** incorporated therein as described above.

[0149] Turning to FIG. 11, illustrated is a block diagram of a wireless lighting system **1100** that utilizes RF signaling to control lighting. The system **1100** includes the wireless light

bulb **1002**, which can further comprise the light source **1006** (e.g., LED(s)), the power source **1008**, and the control component **1010** as described above (e.g., which can be integrated in the wireless light bulb **1002**). Moreover, the wireless light bulb **1002** can include an RF receiver **1102** that can obtain a data stream of RF signals that can be decoded and employed by the control component **1010**.

[0150] The RF receiver **1102** can monitor for RF signals at a predetermined frequency. For instance, the RF receiver **1102** can periodically monitor for RF signals. Alternatively, the RF receiver **1102** can continuously monitor for RF signals. When an RF signal is received, the signal can be decoded (e.g., by the control component **1010**, a processor (not shown)).

[0151] The RF receiver **1102** can receive RF signals communicated by a remote control **1104**. The remote control **1104** can be positioned at substantially any location (e.g., within range of the RF receiver **1102**). Moreover, the remote control **1104** can be employed by a user to operate the wireless light bulb **1002** from a distance. For instance, the remote control **1104** can be located at the top of a stairway and can transmit RF signals to the wireless light bulb **1002** positioned at the bottom of the stairway, where the wireless light bulb **1002** can be mechanically coupled to a fixture located downstairs with or without electrical coupling to a power source (e.g., AC power source). The remote control **1104** can further include a command input component **1106** and an RF transmitter **1108**. Moreover, although not depicted, it is contemplated that the remote control **1104** can include a power source (e.g., one or more batteries). It is also contemplated that the remote control can use AC power as its power source. For example, the remote control function could be a replacement for a traditional light switch such that instead of a toggle switch that makes or breaks AC power to a socket or fixture, the remote control is a wall switch plate that replaces the traditional light switch plate and contains an AC to DC circuit along with an RF transmitter that controls a wireless light bulb with an RF receiver as an input component.

[0152] According to an example, the remote control **1104** can be attachable to a surface such as a wall. Pursuant to another illustration, the remote control **1104** can be attachable to a keychain. However, it is contemplated that the claimed subject matter is not limited to the aforementioned examples.

[0153] The command input component **1106** can be one or more buttons, dials, toggles, switches, levers, knobs, an LED touch screen, a keypad, or any such controls that can obtain user input commands. According to another illustration, the command input component **1106** can be a touch screen device with which a user can interact. The command input component **1106** can receive commands to switch the light source **1006** on, switch the light source **1006** off, toggle whether the light source **1006** is on or off, dim or brighten light generated by the light source **1006**, change the color of the light yielded by the light source **1006**, and so forth.

[0154] Moreover, the RF transmitter **1108** can transfer command(s) obtained via the command input component **1106** to the RF receiver **1102** of the wireless light bulb **1002**. It is contemplated, however, that an infrared (IR) receiver and transmitter can be employed in addition to or instead of the RF receiver **1102** and RF transmitter **1108**. Moreover, it is to be appreciated that the RF receiver **1102** and/or RF transmitter **1108** can be transceivers that can receive and transmit data. Such transceivers can enable two-way communication. Thus, for instance, the remote control **1104** can be configured to

repeatedly transmit a command signal until a configuration signal is received from the wireless light bulb **1002**. Additionally, the wireless light bulb **1002** can transmit a confirmation signal upon receipt of an RF signal. According to another example, RF transceivers can enable providing the remote control **1104** with feedback concerning a state associated with the wireless light bulb **1002** (e.g., whether the light source **1006** is in an on state, an off state, a color and/or intensity of light yielded by the light source **1006**), battery life, and so forth. Moreover, RF transceivers can allow the wireless light bulb **1002** to communicate with disparate wireless light bulb(s) (e.g., to repeat signals, coordinate actions). Pursuant to a further example, the transceiver can enable sending power usage data corresponding to the wireless light bulb **1002** to a disparate device (e.g., for storage, tracking, statistical analysis, billing).

[0155] According to another illustration, the remote control **1104** can manipulate any number of wireless light bulbs similar to the wireless light bulb **1002**. For instance, similar changes in operation of any number of wireless light bulbs can be effectuated by the remote control **1104** and/or the remote control **1104** can communicate respective commands specific for any number of subsets of the wireless light bulbs. Pursuant to a further example, the remote control **1104** can encrypt data communicated to the wireless light bulb **1002** to provide security; therefore, the wireless light bulb **1002** (e.g., the control component **1010**, a processor (not shown)) can decrypt the data received from the remote control **1104** via the RF receiver **1102**.

[0156] Now referring to FIG. 12, illustrated is another block diagram of a system **1200** that provides wireless lighting. The system **1200** includes the wireless light bulb **1002** that can be removably attachable to any type of lighting fixture. Moreover, the lighting fixture can, but need not, provide power to the wireless light bulb **1002**. The wireless light bulb **1002** can include the light source **1006** (e.g., LED(s)), the power source **1008**, and the control component **1010**. Moreover, the wireless light bulb **1002** can include any number of sensor(s) **1202**. In addition to the sensor(s) **1202**, the wireless light bulb **1002** can comprise a receiver that can obtain wireless control signals (e.g., the RF receiver **1102**) or can lack such a receiver. According to a further example, the sensor(s) **1202** can be separate from the wireless light bulb **1002** and can wirelessly transmit information to the wireless light bulb **1002** to control operation thereof while lacking a wired connection to the wireless light bulb **1002**; however, the claimed subject matter is not so limited.

[0157] It is to be appreciated that any type of sensor(s) **1202** can be utilized in connection with the claimed subject matter. For example, the sensor(s) **1202** can be one or more of infrared sensors, light sensors, proximity sensors, acoustic sensors, motion sensors, carbon monoxide and/or smoke detectors, thermal sensors, electromagnetic sensors, mechanical sensors, chemical sensors, and the like. According to an illustration, the wireless light bulb **1002** can include a passive infrared (PIR) sensor that can detect motion. The control component **1010** can determine if the motion detected by the PIR sensor is above a predetermined threshold. If the motion is above the predetermined threshold, the control component **1010** can switch the light source **1006** to an on state. Moreover, the control component **1010** can enable the light source **1006** to emit light for a period of time (e.g., predetermined, dynamically adjusted, as long as the detected motion remains above the threshold) prior to switching the light source **1006**

to an off state. By way of another illustration, the sensor **1202** can be a light sensor that can monitor an amount of light in an environment (e.g., outside during differing times of day); thus, the control component **1010** can enable the light source **1006** to switch on when the amount of light monitored in the environment drops below a threshold (e.g., the light source **1006** can turn on at night and turn off during the day). In accord with another example, the wireless light bulb **1002** can be utilized in connection with providing an alarm (e.g., the wireless light bulb **1002** can yield a visual alarm indication) such that the sensor **1202** can detect a temperature of an environment or a temperature of the bulb itself, and the control component **1010** can enable operating the light source **1006** based upon the observed temperature (e.g., transition the light source **1006** to an on state when the temperature exceeds a threshold). However, the claimed subject matter is not limited to the aforementioned examples.

[0158] With reference to FIG. 13, illustrated is a block diagram of a system **1300** that provides illumination with a wireless light. The system **1300** includes the wireless light bulb **1002** that can further comprise the light source **1006** (e.g., one or more LEDs), the power source **1008**, the control component **1010**, and/or the input component **1012**. The wireless light bulb **1002** can be incorporated into a housing (not shown). It is contemplated that any size and/or shape housing can be employed with the wireless light bulb **1002**. According to another illustration, the housing can include at least a portion that is moveable (e.g., manually by a user, automatically with a motor or the like) to allow for directing emitted light. For example, a remote control can provide a signal to manipulate a moveable portion of the housing. Moreover, the housing can orient the light source **1006** in substantially any manner to provide general lighting (e.g., illuminating an indoor or outdoor area), task lighting (e.g., reading), accent lighting, and so forth.

[0159] The input component **1012** can receive an input from a disparate device (e.g., the remote control **1104** of FIG. 11, a stand-alone sensor). The input component **1012** can provide various adaptors, connectors, channels, communication paths, etc. to enable interaction with the disparate device. Pursuant to an illustration, the input can be wirelessly transmitted (e.g., via an RF signal, an IR signal) from the disparate device to the input component **1012**; thus, the input component **1012** can be a receiver and/or a transceiver that obtains the wirelessly transferred signal. By way of example, an infrared sensor or motion sensor can monitor occupancy in an environment and, upon detecting presence within the monitored environment, the sensor can transmit a wireless input to the input component **1012**. It is to be appreciated that any type of sensors can be utilized in connection with the claimed subject matter such as, but not limited to, infrared sensors, light sensors, proximity sensors, acoustic sensors, motion sensors, carbon monoxide and/or smoke detectors, thermal sensors, electromagnetic sensors, mechanical sensors, chemical sensors, and the like.

[0160] According to another example, any type of remote control can wirelessly communicate with the input component **1012**. For instance, the remote control can be a stand-alone remote control (e.g., the remote control **1104** of FIG. 11) and/or incorporated into a disparate device (e.g., incorporated into a key fob, a programmable wireless transceiver integrated in an automobile). Moreover, the remote control can be a personal computer, a cellular phone, a smart phone, a laptop, a handheld communication device, a handheld com-

puting device, a global positioning system, a personal digital assistant (PDA), and/or any other suitable device; such devices can communicate directly with the input component **1012** and/or via a network (e.g., local area network (LAN), wide area network (WAN), cellular network). By communicating via a network, the wireless light bulb **1002** can be controlled from a remote location (e.g., an individual can control the wireless light bulb **1002** in her home by utilizing a device in her office). Moreover, the aforementioned devices can be utilized to wirelessly program the wireless light bulb **1002**. For instance, operation of a plurality of wireless light bulbs can be programmed from a personal computer (e.g., an RF transmitter can be coupled to a USB port of the computer to communicate with the input component **1012**, the wireless light bulbs can be programmed to switch on and off at certain times of day).

[0161] In accord with another example, radio frequency identification (RFID) can be utilized to provide the input to the input component **1012**. As such, an RFID tag associated with a user can be detected when in range of the input component **1012**, and lighting preferences of the particular user (e.g., retained in memory) can be effectuated in response to his or her detected presence. By way of illustration, when an individual walks into a room in her house with an RFID tag, presence of the RFID tag can be observed by the input component(s) **1012** and the wireless light bulb(s) in the room can switch on, intensity, color, and/or direction of the light(s) can be altered, and so forth; however, the claimed subject matter is not so limited. It is also appreciated that the RFID tag can be read by a RFID reader, the identification of the individual can be processed by a software program running on a computer or server and subsequently the computer or server can switch on, intensity, color, and/or direction of the light(s) can be altered, and so forth based on a stored profile for that individual.

[0162] Additionally or alternatively, the input component **1012** can be a sensor that can monitor a condition associated with the wireless light bulb **1002** to generate the input as described in connection with FIG. 12. According to another example, the input component **1012** can be a connector, port, etc. that couples to such sensor.

[0163] Further, the input component **1012** can wirelessly transmit data (e.g., feedback, related to a current and/or anticipated future state) to a remote device and/or sensor. By way of another example, the input component **1012** can wirelessly communicate with an input component of a disparate wireless light bulb to enable coordinated operation between more than one wireless light bulb. Following this example, an input can be retransmitted within a network of wireless light bulbs, where the network of light bulbs can be dispersed within a geographic area.

[0164] The power source **1008** can be any number and/or type of batteries. For instance, the battery can be a rechargeable battery. According to another example, the battery can be a non-rechargeable battery. The battery supplies power to the wireless light bulb **1002** to enable installing, moving, replacing, etc. the wireless light bulb **1002** in a fixture at substantially any indoor or outdoor location while mitigating the need for expensive and time consuming wiring and/or utilization of aesthetically displeasing and potentially inconvenient cords commonly associated with conventional lighting. Pursuant to a further example, the wireless light bulb **1002** can obtain AC power from the fixture, and the AC power can

supplement the power provided by the power source **1008** and/or be employed instead of power from the power source **1008**.

[0165] According to an example, the light source **1006** can be one or more LEDs. It is contemplated that any number, type, color, arrangement, etc. of LEDs can be utilized with the wireless light bulb **1002**. Further, the control component **1010** can provide instructions to manage operation of the LED(s). For instance, the control component **1010** can yield instructions to switch one or more LEDs on and/or off, change an intensity of illumination (e.g., brightness), switch a wavelength of light emitted from the LEDs (e.g., to change light color), manipulate direction of illumination (e.g., by moving, rotating, etc. one or more of the LEDs) and the like. However, the claimed subject matter is not limited to the light source **1006** including LED(s); rather, it is contemplated that any disparate type of light source **1006** can be employed.

[0166] The control component **1010** employs the input obtained by the input component **1012**. The control component **1010** can further include a state modification component **1302**, a timer component **1304**, an intensity regulation component **1306**, and/or a wavelength control component **1308**; however, it is to be appreciated that the control component **1010** can include a subset of these components **1302-408**. The state modification component **1302** utilizes the input obtained via the input component **1012** to generate an instruction to change a state of the light source **1006**. The state modification component **1302** effectuates transitioning the light source **1006** to an on state, an off state, etc. Further, the state modification component **1302** can yield commands to strobe the light source **1006** (e.g., periodically turning the light source **1006** on and off with substantially any periodicity). According to an example, the state modification component **1302** can decipher that a received input pertains to the light source **1006** and/or a portion thereof (e.g., a subset of LED(s) in an LED array). Moreover, the state modification component **1302** can analyze the input to determine whether to yield instructions to modify operation of the light source **1006** (e.g., compare an input from a sensor to a threshold, evaluate whether a condition has been met, based upon retrieved instructions corresponding to the input retained in memory).

[0167] The timer component **1304** can operate in conjunction with the state modification component **1302**. For instance, the timer component **1304** can enable delaying state changes. Thus, turning the light source **1006** on or off can be delayed for an amount of time by the timer component **1304**. Further, the amount of time for the delay can be predetermined, randomly selected, included with the input obtained by the input component **1012** (e.g., based on a number of times a button of a remote control is depressed), etc. Moreover, the timer component **1304** can enable turning the light source **1006** on and off at certain times (e.g., to create an appearance of someone being in a house when the owner is out of town); for instance, the timer component **1304** can enable the state modification component **1302** to switch the state at preprogrammed times, at times determined according to a random pattern (e.g., randomly switch the light source **1006** on at different times during the day for differing lengths of time), and so forth. Additionally, the timer component **1304** can include a clock that provides an understanding of time of day, day, month, year, etc. for the wireless light bulb **1002**; by way of illustration, the wireless light bulb **1002** can be synchronized with an individual's calendar to enable randomly turning the light source **1006** on and off when the

individual is known to be away from home (e.g., a vacation, meeting, and the like can be scheduled on the calendar), switching the light source **1006** on when the individual is due to return home or guests are scheduled to arrive, and so forth. According to another example, the timer component **1304** can conserve battery life by enabling the state modification component **1302** to switch the light source **1006** to an off state at a particular time of day, after an elapsed amount of time subsequent to an input that turned the light source **1006** to the on state, and so forth. Pursuant to another illustration, the timer component **1304** can operate in conjunction with the intensity regulation component **1306** and/or the wavelength control component **1308** described below.

[0168] The intensity regulation component **1306** can alter the intensity (e.g., brightness) of the light source **1006** based upon the received input from the input component **1012**. The intensity can be changed by the intensity regulation component **1306** adjusting a proportion of LEDs in an on state to LEDs in an off state when the light source **1006** includes an LED array. Additionally or alternatively, the intensity regulation component **1306** can control the intensity of light emitted by each of the LEDs in such an array. Pulse width modulation can be used to adjust the intensity of light of any or all LEDs to the desired intensity. In addition, the intensity regulation component in conjunction with the timer component, functions such as fade to off or fade to a low level of light until an input component detect a condition to transition to a full on state can also be implemented. According to an example, the input component **1012** can obtain RFID related input that identifies the presence of a particular user, and this user can have lighting preferences stored in memory (not shown) associated with the wireless light bulb **1002**. Following this example, the particular user's preferences may indicate that she desires dim lighting, which can be effectuated by the intensity regulation component **1306**. Pursuant to another example, upon a smoke detector or carbon monoxide detector sensing smoke or carbon monoxide, respectively, the intensity regulation component **1306** can increase the brightness of the illumination of the light source **1006** to a highest level (e.g., while the state modification component **1302** can strobe the light source **1006**, the wavelength control component **1308** can change the color). It is to be appreciated, however, that the claimed subject matter is not limited to the aforementioned examples.

[0169] The wavelength control component **1308** can change the wavelength (e.g., color) of light generated by the light source **1006** as a function of the input obtained by the input component **1012**. For example, the light source **1006** can include color changing LEDs, and the wavelength control component **1308** can yield commands to adjust the color based upon the input obtained by the input component **1012**. By way of another example, subsets of LEDs included in the light source **1006** can yield differing colors, and the wavelength control component **1308** can select which of the LED subsets to turn to the on state to yield the desired color.

[0170] By way of further illustration, the control component **1010** can include memory (not shown) that can retain instructions, commands, settings, preferences, calendar data, etc. associated with the wireless light bulb **1002**; additionally or alternatively, the memory can be separate from the control component **1010** (e.g., the wireless light bulb **1002** can include the memory and/or the memory can be separate from the wireless light bulb **1002**). Pursuant to an example, a user can create a lighting profile that regulates operation of the

wireless light bulb **1002**; the lighting profile can be stored in memory and thereafter retrieved (e.g., upon receipt of input via the input component **1012**) for use by the control component **1010** (and/or the state modification component **1302**, the timer component **1304**, the intensity regulation component **1306**, the wavelength control component **1308**). The memory can be, for example, either volatile memory or nonvolatile memory, or can include both volatile and nonvolatile memory. By way of illustration, and not limitation, nonvolatile memory can include read only memory (ROM), programmable ROM (PROM), electrically programmable ROM (EPROM), electrically erasable programmable ROM (EEPROM), or flash memory. Volatile memory can include random access memory (RAM), which acts as external cache memory. By way of illustration and not limitation, RAM is available in many forms such as static RAM (SRAM), dynamic RAM (DRAM), synchronous DRAM (SDRAM), double data rate SDRAM (DDR SDRAM), enhanced SDRAM (ESDRAM), SYNCHLINK DRAM (SLDRAM), RAMBUS direct RAM (RDRAM), direct RAMBUS dynamic RAM (DRDRAM), and RAMBUS dynamic RAM (RDRAM). The memory of the subject systems and methods is intended to comprise, without being limited to, these and any other suitable types of memory. In addition, it is to be appreciated that the memory can be a server, a database, a hard drive, and the like. Further, the control component **1010** (and/or the wireless light bulb **1002**) can include a processor (not shown) to execute instructions described herein.

[0171] Now referring to FIG. 14, illustrated is a system **1400** that recharges a power source (e.g., the power source **1008**) integrated within a wireless light bulb (e.g., the wireless light bulb **1002**). The system **1400** can include the wireless light bulb **1002** and the fixture **1004**. The wireless light bulb **1002** can further include the light source **1006** (e.g., LED(s)), the power source **1008**, the control component **1010**, and/or the input component **1012**. The wireless light bulb **1002** can also include a recharge component **1402** that can recharge the power source **1008**. For example, the recharge component **1402** can enable recharging the power source **1008** when the power source **1008** comprises one or more rechargeable batteries. The light source **1006** can generate light while the recharge component **1402** recharges the power source **1008** (e.g., the wireless light bulb **1002** can be a battery backed up AC light bulb), for instance; however, the claimed subject matter is not so limited.

[0172] In accordance with an illustration, extended use of the wireless light bulb **1002** can decrease a charge of the power source **1008**. For instance, the wireless light bulb **1002** can be utilized with a fixture (e.g., the fixture **1004**) that lacks a connection to a power source (e.g., electrically wired to an AC power source); hence power for operation of the wireless light bulb **1002** can be provided by the power source **1008**. To replenish the charge of the power source **1008**, the wireless light bulb **1002** can be removed from the fixture **1004** and can be coupled to a charger (not shown), for example. When connected to the charger, the recharge component **1402** can increase the charge of the power source **1008**. Following another example, the recharge component **1402** can increase the charge of the power source **1008** when the wireless light bulb **1002** is coupled to a fixture (e.g., the fixture **1004**) that is electrically connected to an AC power source. Therefore, upon charge depletion of the power source **1008** of the wireless light bulb **1002** when connected to a fixture that lacks a connection to an AC power source, the wireless light bulb

1002 can be moved to a fixture that is hard-wired to an AC power source to enable recharging. Additionally, where the fixture **1004** is a lamp, the lamp can be unplugged (e.g., when it is desired to utilize the lamp positioned at a distance from an outlet longer than a length of a cord of the lamp) and the wireless light bulb **1002** can operate by leveraging the power source **1008**, and thereafter, the lamp can be plugged into an outlet to allow the recharge component **1402** to increase the charge of the power source **1008**. According to another illustration, the recharge component **1402** can be a solar cell (or a plurality of solar cells) that can increase the charge of the power source **1008**.

[**0173**] Turning to FIG. 15, illustrated is a system **1500** that coordinates operation of a set of wireless light bulbs. The system **1500** includes a coordinated lighting group **1502** which can include any number N of wireless light bulbs (as shown by the series of wireless light bulbs from wireless light bulb **1504** through wireless light bulb **1514**), where N can be substantially any integer. The N wireless light bulbs **1504-1514** can each be substantially similar to the wireless light bulb **1002** described above. Moreover, each of the wireless light bulbs **1504-1514** can include a respective grouping component and transceiver (e.g., wireless light bulb **1504** can include a grouping component **1506** and a transceiver **1508** and wireless light bulb N **1506** can include a grouping component **1510** and a transceiver **1512**).

[**0174**] The wireless light bulbs **1504-1514** in the coordinated lighting group **1502** can be controlled with a common remote control (e.g., the remote control **1104** of FIG. 11) and/or sensor(s), for instance. According to another example, operation of the wireless light bulbs **1504-1514** or a subset thereof can be coordinated. Thus, at least a subset of the wireless light bulbs **1504-1514** can concurrently switch from an on state to an off state, or vice versa, when the respective transceivers **1508**, **1512** obtain such an input signal from the common remote control and/or sensor(s). It is to be appreciated that the coordinated lighting group **1502** can be programmed in substantially any manner to manage operations of the wireless light bulbs **1504-1514** as a group.

[**0175**] The grouping components **1506**, **1510** can enable the coordinated lighting group **1502** to be assembled. For instance, the grouping components **1506**, **1510** can allow each of the wireless light bulbs **1504-1514** to be assigned to operate upon a particular RF frequency (e.g., channel). Thus, the grouping components **1506**, **1510** can select the channel corresponding to the coordinated lighting group **1502** for each respective wireless light bulb **1504-1514**. For example, the channel can be user selected, preprogrammed, randomly generated, previously stored in memory, etc. According to another illustration, the grouping components **1506**, **1510** can learn the channel related to the coordinated lighting group **1502**. Following this illustration, when initializing the wireless light bulb **1504**, the transceiver **1508** can obtain a setup signal from a remote control, sensor, etc. associated with the coordinated lighting group **1502**, and the grouping component **1506** can utilize the setup signal to learn the channel associated with the remote control, sensor, etc. However, it is contemplated that the claimed subject matter is not limited to the aforementioned examples.

[**0176**] FIGS. 15-16 illustrate methodologies in accordance with the claimed subject matter. For simplicity of explanation, the methodologies are depicted and described as a series of acts. It is to be understood and appreciated that the subject innovation is not limited by the acts illustrated and/or by the

order of acts, for example acts can occur in various orders and/or concurrently, and with other acts not presented and described herein. Furthermore, not all illustrated acts may be required to implement the methodologies in accordance with the claimed subject matter. In addition, those skilled in the art will understand and appreciate that the methodologies could alternatively be represented as a series of interrelated states via a state diagram or events.

[**0177**] With reference to FIG. 16, illustrated is a methodology **1600** that facilitates selectively emitting light in accordance with a wireless input. At **1602**, an input can be wirelessly obtained with a receiver integrated in a light bulb. The input can control illumination of a light source of the light bulb. Further, the input can be obtained from any type of source (e.g., remote control, disparate wireless light bulb, differing device, sensor). Moreover, the input can be provided from the source via an RF signal, an IR signal, and so forth. At **1604**, the input can be analyzed to determine whether to adjust the illumination of the light source. For example, the light source can include one or more LEDs. Following this example, if the input provides a command to toggle the state of the LEDs, then an instruction can be yielded to switch the LEDs from an on state to an off state (or vice versa). At **1606**, the illumination of the light source can be selectively altered based on the analyzed input. For example, the light source can be switched to an on state or an off state, the intensity or color of light emitted by the light source can be modified, and the like.

[**0178**] Turning now to FIG. 17, illustrated is a methodology **1700** that facilitates selectively emitting light based upon input from a sensor. At **1702**, a condition within an environment can be monitored with a sensor integrated in a light bulb. The sensor, for example, can be one or more infrared sensors, light sensors, proximity sensors, acoustic sensors, motion sensors, carbon monoxide and/or smoke detectors, thermal sensors, electromagnetic sensors, mechanical sensors, chemical sensors, and the like. At **1704**, a determination can be effectuated regarding whether to alter illumination of a light source powered by a battery based upon the monitored condition, where the light source and the battery can be integrated in the light bulb. For example, the determination can be made by comparing the monitored condition to a threshold. Additionally, the determination can be based at least in part upon considerations related to a current state associated with the light source, a charge level of the battery, and so forth. At **1706**, the illumination of the light source can be selectively adjusted based on the monitored condition. Pursuant to an illustration, the light source can be switched to an on state when a darkness level exceeds a threshold (e.g., at night) and thereafter the light source can be transitioned to an off state when the amount of light increases (e.g., during the day); it is contemplated, however, that the claimed subject matter is not so limited.

[**0179**] In order to provide additional context for implementing various aspects of the claimed subject matter, FIGS. 18-19 and the following discussion is intended to provide a brief, general description of a suitable computing environment in which the various aspects of the subject innovation may be implemented. For instance, FIGS. 18-19 set forth a suitable computing environment that can be employed in connection with programming, controlling, coordinating, monitoring, etc. one or more wireless light bulbs described herein. While the claimed subject matter has been described above in the general context of computer-executable instruc-

tions of a computer program that runs on a local computer and/or remote computer, those skilled in the art will recognize that the subject innovation also may be implemented in combination with other program modules. Generally, program modules include routines, programs, components, data structures, etc., that perform particular tasks and/or implement particular abstract data types. It is to be appreciated, however, that the claimed subject matter is not limited to being employed in connection with the example computing environment set forth in FIGS. 18-19.

[0180] Moreover, those skilled in the art will appreciate that the inventive methods may be practiced with other computer system configurations, including single-processor or multi-processor computer systems, minicomputers, mainframe computers, as well as personal computers, hand-held computing devices, microprocessor-based and/or programmable consumer electronics, and the like, each of which may operatively communicate with one or more associated devices. The illustrated aspects of the claimed subject matter may also be practiced in distributed computing environments where certain tasks are performed by remote processing devices that are linked through a communications network. However, some, if not all, aspects of the subject innovation may be practiced on stand-alone computers. In a distributed computing environment, program modules may be located in local and/or remote memory storage devices.

[0181] FIG. 18 is a schematic block diagram of a sample-computing environment 1800 with which the claimed subject matter can interact. The sample-computing environment 1800 includes one or more client(s) 1810. The client(s) 1810 can be hardware and/or software (e.g., threads, processes, computing devices). The sample-computing environment 1800 also includes one or more server(s) 1820. The server(s) 1820 can be hardware and/or software (e.g., threads, processes, computing devices). The servers 1820 can house threads to perform transformations by employing the subject innovation, for example.

[0182] One possible communication between a client 1810 and a server 1820 can be in the form of a data packet adapted to be transmitted between two or more computer processes. The sample-computing environment 1800 includes a communication framework 1840 that can be employed to facilitate communications between the client(s) 1810 and the server(s) 1820. The client(s) 1810 are operatively connected to one or more client data store(s) 1850 that can be employed to store information local to the client(s) 1810. Similarly, the server(s) 1820 are operatively connected to one or more server data store(s) 1830 that can be employed to store information local to the servers 1820.

[0183] With reference to FIG. 19, an exemplary environment 1900 for implementing various aspects of the claimed subject matter includes a computer 1912. The computer 1912 includes a processing unit 1914, a system memory 1916, and a system bus 1918. The system bus 1918 couples system components including, but not limited to, the system memory 1916 to the processing unit 1914. The processing unit 1914 can be any of various available processors. Dual microprocessors and other multiprocessor architectures also can be employed as the processing unit 1914.

[0184] The system bus 1918 can be any of several types of bus structure(s) including the memory bus or memory controller, a peripheral bus or external bus, and/or a local bus using any variety of available bus architectures including, but not limited to, Industrial Standard Architecture (ISA), Micro-

Channel Architecture (MSA), Extended ISA (EISA), Intelligent Drive Electronics (IDE), VESA Local Bus (VLB), Peripheral Component Interconnect (PCI), Card Bus, Universal Serial Bus (USB), Advanced Graphics Port (AGP), Personal Computer Memory Card International Association bus (PCMCIA), FIREWIRE (IEEE 1394), and Small Computer Systems Interface (SCSI).

[0185] The system memory 1916 includes volatile memory 1920 and nonvolatile memory 1922. The basic input/output system (BIOS), containing the basic routines to transfer information between elements within the computer 1912, such as during start-up, is stored in nonvolatile memory 1922. By way of illustration, and not limitation, nonvolatile memory 1922 can include read only memory (ROM), programmable ROM (PROM), electrically programmable ROM (EPROM), electrically erasable programmable ROM (EEPROM), or flash memory. Volatile memory 1920 includes random access memory (RAM), which acts as external cache memory. By way of illustration and not limitation, RAM is available in many forms such as static RAM (SRAM), dynamic RAM (DRAM), synchronous DRAM (SDRAM), double data rate SDRAM (DDR SDRAM), enhanced SDRAM (ESDRAM), SYNCHLINK DRAM (SLDRAM), RAMBUS direct RAM (RDRAM), direct RAMBUS dynamic RAM (DRDRAM), and RAMBUS dynamic RAM (RDRAM).

[0186] Computer 1912 also includes removable/non-removable, volatile/non-volatile computer storage media. FIG. 19 illustrates, for example a disk storage 1924. Disk storage 1924 includes, but is not limited to, devices like a magnetic disk drive, floppy disk drive, tape drive, JAZ drive, ZIP drive, LS-100 drive, flash memory card, or memory stick. In addition, disk storage 1924 can include storage media separately or in combination with other storage media including, but not limited to, an optical disk drive such as a compact disk ROM device (CD-ROM), CD recordable drive (CD-R Drive), CD rewritable drive (CD-RW Drive) or a digital versatile disk ROM drive (DVD-ROM). To facilitate connection of the disk storage 1924 to the system bus 1918, a removable or non-removable interface is typically used such as interface 1926.

[0187] It is to be appreciated that FIG. 19 describes software that acts as an intermediary between users and the basic computer resources described in the exemplary environment 1900. Such software includes an operating system 1928. Operating system 1928, which can be stored on disk storage 1924, acts to control and allocate resources of the computer 1912. System applications 1930 take advantage of the management of resources by operating system 1928 through program modules 1932 and program data 1934 stored either in system memory 1916 or on disk storage 1924. It is to be appreciated that the claimed subject matter can be implemented with various operating systems or combinations of operating systems.

[0188] A user enters commands or information into the computer 1912 through input device(s) 1936. Input devices 1936 include, but are not limited to, a pointing device such as a mouse, trackball, stylus, touch pad, keyboard, microphone, joystick, game pad, satellite dish, scanner, TV tuner card, digital camera, digital video camera, web camera, and the like. These and other input devices connect to the processing unit 1914 through the system bus 1918 via interface port(s) 1938. Interface port(s) 1938 include, for example, a serial port, a parallel port, a game port, and a universal serial bus (USB). Output device(s) 1940 use some of the same type of ports as input device(s) 1936. Thus, for example, a USB port

may be used to provide input to computer 1912, and to output information from computer 1912 to an output device 1940. Output adapter 1942 is provided to illustrate that there are some output devices 1940 like monitors, speakers, and printers, among other output devices 1940, which require special adapters. The output adapters 1942 include, by way of illustration and not limitation, video and sound cards that provide a means of connection between the output device 1940 and the system bus 1918. It should be noted that other devices and/or systems of devices provide both input and output capabilities such as remote computer(s) 1944.

[0189] Computer 1912 can operate in a networked environment using logical connections to one or more remote computers, such as remote computer(s) 1944. The remote computer(s) 1944 can be a personal computer, a server, a router, a network PC, a workstation, a microprocessor based appliance, a peer device or other common network node and the like, and typically includes many or all of the elements described relative to computer 1912. For purposes of brevity, only a memory storage device 1946 is illustrated with remote computer(s) 1944. Remote computer(s) 1944 is logically connected to computer 1912 through a network interface 1948 and then physically connected via communication connection 1950. Network interface 1948 encompasses wire and/or wireless communication networks such as local-area networks (LAN) and wide-area networks (WAN). LAN technologies include Fiber Distributed Data Interface (FDDI), Copper Distributed Data Interface (CDDI), Ethernet, Token Ring and the like. WAN technologies include, but are not limited to, point-to-point links, circuit switching networks like Integrated Services Digital Networks (ISDN) and variations thereon, packet switching networks, and Digital Subscriber Lines (DSL).

[0190] Communication connection(s) 1950 refers to the hardware/software employed to connect the network interface 1948 to the system bus 1918. While communication connection 1950 is shown for illustrative clarity inside computer 1912, it can also be external to computer 1912. The hardware/software necessary for connection to the network interface 1948 includes, for exemplary purposes only, internal and external technologies such as, modems including regular telephone grade modems, cable modems and DSL modems, ISDN adapters, and Ethernet cards.

[0191] Some embodiments may include an auto shutoff feature. This feature may be set by toggling or setting a switch, may be programmable, may be responsive to a battery's level, may include fade-to-off effect, and so on.

[0192] A variety of products and applications in accordance with the foregoing are possible. Without limitation, these products and applications include a closet light, a sconce, an under cabinet light, a pendant light, a track light, a night light, a spotlight (indoor or outdoor), a stair light, a path light, a deck light, a porch light, an address marker light, a mailbox light, a picture light, a plant light, a tree light, a flower bed light, a cove light, a light bulb (e.g. PAR30, PAR38, MR16, A19, A26, and so on), and so forth. In embodiments, the light bulb may be AC powered (e.g. an incandescent replacement); may include a motion sensor; may include a light sensor; may include an RF or IR receiver, transmitter, or transceiver; may include an embedded battery; may include an embedded programmable timer control; may include a charger base and battery embedded bulb; and so on. In embodiments having an embedded battery products and applications may include a "fixture anywhere" battery pow-

ered bulb; a "lamp anywhere" battery powered bulb; an "uninterruptible power supply-type bulb" that is AC powered, switches over to battery power when the AC power fails, and can be toggled on/off regardless of whether the AC power has failed; an "emergency light bulb" that is battery powered and switches on when AC power fails; an "emergency battery backed LED down light/florescent light", which is similar to the emergency light bulb except that the batteries are mounted in the down light fixture or fluorescent bulb, fixture or ballast. In embodiments having an embedded programmable timer control, the light bulb may turn on and off at certain times and may operate in an "at home" mode, an "away" mode, and so on.

[0193] Further products and applications may include a for sale sign, a light adapted for boating or water sports, a street lamp, a driveway light, a reading light, a pool light (e.g. a waterproof or water resistant light), an LED "throwie" (e.g. an LED lamp that can be placed by hand), a camping light, a warning light, a light adapted for a signage application, a light for non-automotive vehicles (e.g. a personal vehicle such as a bicycle, scooter, skateboard, SEGWAY, stroller, or the like), a light adapted for automotive vehicles (e.g. an interior or exterior retrofit light, an RV light, a bus light, and so on), a campus light, a parking garage light, a light adapted for emergency responder applications, a battery-backed industrial fixture (e.g. hallway or stairwell lights, down-lighting, and so on), and so forth.

[0194] Embodiments may be suitable for a variety of use scenarios. Use of embodiments in integrated systems may, without limitation, include automotive lighting systems, military lighting systems, emergency response systems, campus lighting, parking garage lighting systems, outdoor lighting systems, and so on. Embodiments may be sold in a kit that includes instructions for use. Such kits may be directed at residential use, including without limitation a basketball court lighting kit, a playground lighting kit, a hot tub lighting kit, a fall-prevention lighting kit (indoor or outdoor), a front walkway lighting kit, a garage lighting kit, a shed lighting kit, a gazebo lighting kit, a deck and patio lighting kit, a dock lighting kit, a dock lighting kit, an animal deterrent kit, a power outage lighting kit, a boat lighting kit, a house perimeter lighting kit, a tennis court lighting kit, a dorm room lighting kit, and so on. Such kits may be directed at commercial and industrial applications including, without limitation, a new construction lighting kit, an office night ext lighting kit, a warehouse supplemental lighting kit, a storage unit facility lighting kit, a stair emergency lighting kit, and so on.

[0195] Without limitation, embodiments may include an RF-controlled closet light, an RF-controlled spotlight, an RF-controlled stair light, an RF-controlled deck light, a motion-responsive closet light, a motion-responsive spotlight, a motion-responsive stair light, a motion-responsive sensor light, a motion light bulb, an RF-controlled light bulb, a light-responsive light bulb, and so on.

[0196] What has been described above includes examples of the subject innovation. It is, of course, not possible to describe every conceivable combination of components or methodologies for purposes of describing the claimed subject matter, but one of ordinary skill in the art may recognize that many further combinations and permutations of the subject innovation are possible. Accordingly, the claimed subject matter is intended to embrace all such alterations, modifications, and variations that fall within the spirit and scope of the appended claims.

[0197] In particular and in regard to the various functions performed by the above described components, devices, circuits, systems and the like, the terms (including a reference to a “means”) used to describe such components are intended to correspond, unless otherwise indicated, to any component which performs the specified function of the described component (e.g., a functional equivalent), even though not structurally equivalent to the disclosed structure, which performs the function in the herein illustrated exemplary aspects of the claimed subject matter. In this regard, it will also be recognized that the innovation includes a system as well as a computer-readable medium having computer-executable instructions for performing the acts and/or events of the various methods of the claimed subject matter.

[0198] In addition, while a particular feature of the subject innovation may have been disclosed with respect to only one of several implementations, such feature may be combined with one or more other features of the other implementations as may be desired and advantageous for any given or particular application. Furthermore, to the extent that the terms “includes,” and “including” and variants thereof are used in either the detailed description or the claims, these terms are intended to be inclusive in a manner similar to the term “comprising.”

[0199] In a second illustrative embodiment, a version of the wireless light bulb is a motion controlled, light sensor activated LED light bulb. With reference to FIG. 20, illustrated is a perspective view of an embodiment of a motion wireless light bulb 2000. In the illustrated embodiment, the motion wireless light bulb 2000 includes a housing 2010, a plurality of LEDs 2020, a motion sensor 2030, logic 2040, power circuitry 2050 and a light socket adapter 2060. In the illustrated embodiment, the motion wireless light bulb 2000 includes 3 LEDs. In alternative embodiments, a motion wireless light bulb 2000 may include more LEDs 2020 to provide greater illumination or fewer LEDs 2020 to use less power. It is to be appreciated that the motion wireless light bulb 2000 can include any number of LEDs 2020, and the LEDs 2020 can be positioned at substantially any locations with respect to one another as well as in comparison to the housing 2010. It is noted that the motion wireless light bulb 2000 can be designed in any size or shape so that the housing 2010 meets the requirements of any standard size bulb (PAR30, PAR38, A19, R30, MR16, and so on), non-standard size bulb, fixture, fluorescent bulb or lamp (T4, T5, T8, circular, and so on) or down light assembly (recessed fixtures, fluorescent fixtures or down light fixtures for residential or industrial lighting), or the like. In alternate embodiments, any type of wireless light bulb mentioned herein can be designed in any size or shape housing to meet the requirements of any standard size bulb (PAR30, PAR38, A19, R30, MR16 etc), non-standard size bulb, fixture, fluorescent bulbs or lamps (T4, T5, T8, circular, and so on) or down light assembly (recessed fixtures, fluorescent fixtures or down light fixtures for residential or industrial lighting), or the like. It is also to be appreciated that the light socket adapter 2060 can be designed to interface electrically and mechanically with any standard size or non-standard size bulb socket including screw thread bases, bayonet bases, pin bases and any other kind of special lamp base that can be used. In the illustrated embodiment, the motion wireless light bulb 2000 illuminates an area of approximately twenty square feet when above the ground ten feet pointing directly down. Alternate embodiments may include but are not limited to any known light source including LEDs, com-

pact fluorescent, fluorescent, induction, halogen, gas discharge, organic LEDs (OLED), plasma, radio generated plasma and incandescent bulbs and can illuminate any size area.

[0200] In the illustrated embodiment, the housing 2010 is constructed of plastic. Alternatively, the housing 2010 can be constructed of metal or any other known material. In one embodiment the housing can be waterproof, shatterproof, UV resistant and/or corrosion resistant for use outdoors or difficult environments. The material of the housing can serve as a heat sink and can be constructed of a material to dissipate or conduct heat away from the LEDs to improve the performance and extend the life of the LEDs.

[0201] In the illustrated embodiment the housing 2010 includes a reflector for each LED to reflect the light from the LEDs to provide a distinct area of coverage. In other embodiments, an optical lens or lenses or reflectors can direct the light, reflect the light or change the viewing angle of the LEDs. The housing of the bulb may include any number of optical elements. The optical elements may serve to focus, diffuse, filter, collimate, or otherwise affect light produced by the LEDs 2020. In embodiments, the optical elements may include one or more lenses, reflectors, optical filters, aperture, and so on. The lenses may be fixed, a multiple lens array, adjustable, and so on. The lenses or reflectors may be manually adjustable, motorized with direct control with switches on the unit for adjusting the direction or characteristics of the light source, motorized with a remote control for adjusting the direction or characteristics of the light source through RF or IR control or it may detect motion and automatically adjust the lenses or reflectors to aim the light in the direction of the motion. An example use of the embodiment where the lenses or reflectors are automatically adjusted based on the direction in which motion is detected is several light bulbs can adjust to direct light in the direction of the motion adding illumination to the object in motion thereby allowing the individual light bulbs to be smaller and require less power but still resulting in a necessary amount of light on the object in motion. In some embodiments, there may be an array of optical elements that are pointed in fixed directions such that the light may be redirected by turning on LEDs pointing in a desired direction with a desired light output and turning off LEDs that may not point in the desired direction or provide the desired light output. Thus, the directionality of the light is achieved based on which LEDs are on and which LEDs are off in the embodiment.

[0202] With continued reference to illustrated embodiment shown in FIG. 20 one input component is a motion sensor. When the motion sensor 2030 detects motion, logic 2040 determines if the motion is above a predetermined threshold. If the motion is above the predetermined threshold, the logic 2040 instructs an LED controller to turn on at least one LED. The motion sensor will only be operational if a second input component, a light sensor, detects that detected light is at a low enough level to allow the motion sensor 2030 to control the LEDs to turn on (i.e. the bulb will only work in the dark or whatever low light level is set by the light sensor and its detection circuitry). In an alternate embodiment the light sensor is not present and the bulb works only based on the state of the motion sensor 2030.

[0203] In the illustrated embodiment, after the LEDs are turned on, the logic 2040 starts a timer. The logic will then instruct the LED controller to turn off the LEDs if no motion is detected before the timer reaches a predetermined timer

threshold. If motion is detected before the timer reaches the timer threshold, the LEDs will remain on and the timer will reset to the timer starting point. The illustrated embodiment includes this auto shutoff feature to provide efficient energy usage by shutting off or limiting power consumption by the light source when motion is not detected. This feature is factory set via a timer that expires such that after turn on, if there is no reactivation of the control to turn the LEDs on, the unit will automatically turn the LEDs off when the timer expires. In alternate embodiments, there may be more than one auto shutoff timer, there may be an adjustable auto shutoff timer with a method to select the desired auto shutoff time, and the like. This feature may be set by toggling or setting a switch or switches, may be dial selectable, may be set by a potentiometer, may be programmable directly or by remote, and so on.

[0204] In the illustrated embodiment, the timer consists of an RC electrical circuit that discharges to the factory set voltage threshold over some period of time at which time, if not retriggered, will automatically shut off the LEDs. Other embodiments may have a timer built in any known timer circuit and allow features based on the timer value that automatically shut off the LEDs, automatically turn on the LEDs or automatically change the light intensity level. This feature may be set by toggling or setting a switch, may be dial selectable, may be set by a potentiometer, may be programmable directly or by remote, may include a fade-to-off effect, fade-to-dim effect, fade-to-glow effect, fade from one light intensity level to another light intensity level and so on. In some embodiments, the feature may include an increase in light intensity over time which may include an off-to-glow effect, glow-to-dim, glow-to-some light intensity level, an increase from one light intensity level to a higher light intensity level and so on. It is to be appreciated that the change from one light intensity level to another light intensity level may happen over any period of time that may be implemented with the timers. A second feature may have two or more auto shutoff levels set by multiple timers. For example the auto shutoff feature may control the light from bright to dim when the first timer expires and from dim to off when the second timer expires and so on. It is to be appreciated that any form of control by a wireless light bulb or wireless lighting module may trigger the feature of changing the lighting intensity level from one level to another including wireless control, direct control or intelligent programming to change the state.

[0205] Other embodiments can include a circuit that allows the unit to glow at a level such that the unit can be a marker in a dark environment and when motion is detected it turns on to a bright level for illumination to a level that a user can find their way. An alternate embodiment would include a circuit that allows the bulb to be on at a low light level to illuminate an area with enough light to see the area from a distance and when motion is detected the LEDs turn on to a bright level for illumination to a level that a user can accomplish any task desired. In another embodiment, the low light level blinks at some rate to provide a marker until a sensor triggers transitioning to a bright level. In some embodiments, the control of the brightness level at glow, low, bright or any brightness level the user may desire is controlled by a dial, buttons, switches, RF/IR remote or any other known control to allow the user to set the different light levels to the individual user preference.

[0206] In another embodiment, the light can be programmed to fade over time such that the light is activated and slowly fades until it reaches either a glow level or a low light

level. An example of this application is a wireless light bulb plugged into a light socket or lamp in the bedroom of a child that is on when they go to bed at night, but fades over time to a glow level or a low light level as they fall asleep. The design can include any controls, methods and circuits by which to achieve multiple light levels. In addition the design may include methods and circuits to achieve constant current control to achieve consistent brightness at the different light levels.

[0207] In the illustrated embodiment, the motion wireless light bulb **2000** includes a passive infrared sensor configured to detect motion. In one embodiment, the passive infrared sensor has a range of approximately 10 feet and a viewing angle of 45 degrees. In alternative embodiments, the passive infrared sensor may have a range and viewing angle of any known passive infrared sensor. In one alternative embodiment, the passive infrared sensor is removably connected to the unit so that a user may connect any appropriate sensor. In some embodiments, the passive infrared sensor may be replaced or enhanced by a radar sensor, an ultrasound sensor, or any and all other form of motion sensor.

[0208] In other embodiments, any and all sensors may include a detection threshold or false detection rate that can be configured according to a user's preference. For example and without limitation, a light sensor may be configured to detect when incoming light crosses a user-preferred intensity threshold. The light sensor may contain many thresholds that can be detected. In such an example, the light source may be controlled in a different way upon each crossing of a threshold. For example, between any two thresholds detectable by the light sensor, the light source may be set to a particular brightness level. In such a case, as the ambient light increases or decreases (during dawn or dusk for example), the light source may slowly decrease or increase its brightness level based on preset levels. It is to be appreciated that hysteresis may be built in at the crossing of a threshold. It is also to be appreciated that there may be no thresholds and the light intensity is set based on the ambient light level detected such that the ambient light plus the light generated by the light source maintain a constant light level as set in the design or as set by the user. Control of this function may be done in the electrical circuit, done by a microcontroller, may include programmable thresholds, etc. A variety of other such examples will be appreciated, all of which are within the scope of the present disclosure.

[0209] In the illustrated embodiment, a Fresnel lens enables motion detections. The motion detector includes a Fresnel lens that guides infrared light over the PIR sensor in a substantially repeating pattern as a heat source (such as a person, vehicle, and so on) passes in front of the lens. The combination of the passive infrared sensor and Fresnel lens has a range of 15 feet and a viewing angle of 90 degrees. In embodiments, the Fresnel lens may be selected to provide a desired zone of coverage. It will be understood that a variety of embodiments of motion detectors including or excluding the Fresnel lens are possible.

[0210] With continued reference to FIG. 20, when the motion sensor **2030** detects motion, logic **2040** determines if the motion is above a predetermined threshold. If the motion is above the predetermined threshold, the logic **2040** instructs an LED controller to turn on at least one LED **2020**. After the at least one LED **2020** is turned on, the logic **2040** starts a timer. The logic **2040** will then instruct the LED controller to turn off the at least one LED **2020** if no motion is detected

before the timer reaches a predetermined threshold. In an alternate embodiment, the logic will control at least one LED **2020** to revert to a glow or low light level when the timer reaches a predetermined threshold to conserve energy but also provide a low level of light until motion is detected to turn on to the bright light level. In an alternate embodiment, the logic **2040** can maintain the bright light level for some period of time, but then can control the light to fade to off, to a glow or to a low light level by slowly dimming the at least one LED through pulse width modulation or any other known method over some preset or programmable period of time until it reaches off, the glow or the low light level.

[0211] A wireless light bulb can be controlled by any type of input signal that can be leveraged by the logic to manipulate operation of the LEDs. Thus, the input component can be a radio frequency (RF) or infrared (IR) receiver that can obtain an RF or IR signal communicated from an RF or IR transmitter that can be utilized by the logic to control operation of the LEDs. The RF or IR transmitter can come in the form of remote control, key fob, wall switch or any other controller that can house the RF or IR circuitry and user control mechanism. According to this example, the RF or IR transmission can be deciphered by the input component to effectuate switching the LEDs to an on or off state, changing a light color or a light intensity provided by the LEDs, and the like. By way of an example, dimming commands can control the wireless light bulb to specific levels in response to commands received from the RF or IR transmitter in a remote control or wall switch. Controls (mode buttons, control wheel, etc) on a remote control or wall switch can increase or decrease the light level, set the level to glow, low, high light level or the like directly. By way of an example, a PAR30 type AC powered wireless light bulb can be controlled by RF or by the wall switch with the light source AC powered. This type of wireless light bulb can be installed in a porch light fixture. The porch light can be controlled by a wall switch inside of a house, but also be controlled by a RF remote control. This is useful because it allows the porch light to be turned on from a car as the car enters a driveway. This may eliminate the need to keep the porch light on all of the time that the user is away from the house, but still allowing them to use the porch light to illuminate the area when needed.

[0212] In an alternate embodiment, a network of wireless light bulbs can be created by embedding an RF transceiver with intelligence (microcontroller, microprocessor, integrated circuit etc.) in the wireless light bulbs and using a communication protocol between the bulbs to control any size group of bulbs to accomplish any task described herein. Other control sources designed to communicate through the network such as wall switches, key fobs, remote controls, RF adapters that can plug into a computer and be controlled by a software program, etc. can also connect to the network and control wireless light bulbs in the network. By way of an example, the wireless light bulbs are a combination of RF transceiver and motion sensor. If one bulb detects motion, it sends out a message to all bulbs via its RF transmitter to turn all of the bulbs on to a specific brightness level. Bulbs can also receive a message via its RF receiver and retransmit it via its RF transmitter to extend the range of lights beyond what is within the range of the initial unit that detected motion. In an alternate example, the control source may be one or more remote controls with a push button that is pressed to turn the lights on and a push button, that is pressed to turn the lights off with a unique identifier that can be set that can select the

wireless light bulbs to control, and the like. When either button is pressed, a command is transmitted by a remote control to the network to control the bulbs that receive it. The command may also be propagated through the network of bulbs via the RF transceiver in each bulb to control a portion of or the entire network of wireless light bulbs. It is to be appreciated that the bulbs can use any type of networking protocol (routing, flooding etc.) that may effectively distribute state information through the network of bulbs. When the auto shutoff timer of the originating wireless light bulb times out, it can send an off command which is also propagated through the network of light bulbs to shut them all off. The triggering method can be any method sensor described herein and the sending of signals from one wireless light bulb to another can be RF/IF, wired or wireless network (WIFI, ZIG-BEE, X10 etc.) or wired with any electrical control mechanism between wireless light bulbs that can be defined.

[0213] Additionally or alternatively, the input component can be one or more sensors that monitor a condition, and monitored information yielded by such sensor(s) can be utilized to effectuate adjustments associated with the LEDs. It is to be appreciated that any type of sensor(s) can be utilized in connection with the claimed subject matter instead of or in conjunction with a motion sensor. For example, the sensor(s) can be one or more of infrared sensors, light sensors, proximity sensors, magnetic switch sensor, acoustic sensors, voice activated sensor, motion sensors, radar sensors, sonar sensors, carbon monoxide and/or smoke detectors, thermal sensors, electromagnetic sensors, mechanical sensors, chemical sensors, pressure sensor, RFID tag reader or detection circuit and the like. According to another example, the input component can be a connector, port, etc. that couples to a disparate device, sensor, etc. to receive the input signal. It is also appreciated that any combination of sensors can be utilized in connection with the claimed subject matter. The characteristics of the light output (off, glow, on at low level, on at bright level, color etc) and the transition between those characteristics can be controlled by any detectable state of the sensor or sensors. It is also to be appreciated that intelligence in the form of logic, electrical circuitry, microcontrollers, microprocessors, memory devices etc. contained in the bulb can leverage the sensors to monitor patterns of RF, IR or sensor inputs, keep the patterns in memory over time if necessary and adjust individual light characteristics based on the patterns detected. Thus the wireless light bulb has the ability to learn from inputs from its environment and change behavior accordingly.

[0214] The illustrated embodiment is a combination of a light sensor that will minimize power consumption by only allowing the LEDs to turn on when there is a low level of light in the environment and a motion sensor. When there is enough light in the environment, the motion sensor will control the LEDs to turn on when motion is detected. An alternate embodiment includes an RF receiver and motion sensor in the wireless light bulb and separate RF transmitter remote control that can override motion sensor control of the bulb when a user desires that it is turned on for an extended period of time or controlled remotely rather than by motion. One or more wireless light bulbs are controlled by either the motion sensors on the bulbs, by a separate RF remote control, RF wall switch or the like. The RF control element is used to turn on, turn off, control dimming, program timers for automatic control etc. in the wireless light bulbs. In an alternate embodiment, the remote control element contains a motion sensor

and an RF transmitter to transmit commands based on motion detection or switches, buttons, dials or other controls on the remote control element to the one or more wireless light bulbs. The wireless light bulbs have an RF receiver but may or may not have a motion sensor.

[0215] In an alternate embodiment, the wireless light bulb can be controlled by only a light sensor. In this embodiment, the light will only turn on in a low level of light. Thus, when AC power is applied to the bulb and the level of ambient light is low enough, the bulb will turn on, otherwise it will remain off. Alternately, the light source can be controlled based on the amount of light detected from the light sensor such that it turns on slowly in the evening as it gets darker outside and fades to off in the morning as the amount of ambient light increases slowly. For example, a pulse width modulation circuit or other brightness control can be set based on the state of the light sensor. In some embodiments a daylight harvesting function may be implemented where the light intensity is set based on the ambient light level detected such that the ambient light plus the light generated by the light source maintain a constant light level as set in the design or as set by the user. The light sensor light bulb can be used outside such that power on the wired circuit can be turned on all of the time, but the light sensor light bulb will not consume power from the wired circuit other than to power the light sensor associated circuit until the light sensor enables the bulb for operation.

[0216] Another alternative embodiment includes one or more wireless light bulbs with an RF receiver and a light sensor as input components controlling the light source and an RF transmitter remote combined with a motion sensor. The one or more wireless light bulbs may or may not glow all through the night. An example use of this embodiment is a driveway sensor that detects a car triggering the motion sensor to send an RF transmission to the light when the car enters the driveway. The light can stay on for some user set amount of time, for example ten minutes, then auto shutoff or revert to glow mode. In alternate embodiments, the RF transmitter and motion sensor may contain additional controls. For example, the RF transmitter and motion sensor may contain an on switch, off switch, toggle switch, dimmer control switches, motion sensitivity controls, a light sensor with and without sensitivity controls, shutoff timer controls, and the like, or any other type of control mentioned herein. By way of an example, an RF transmitter and motion sensor may contain an OFF push button. The unit may send an ON control message to a wireless light bulb or battery powered wireless lighting fixture when motion is detected to turn the light on. It may contain an auto-shutoff timer that may send an OFF control message when the auto-shutoff timer expires. In addition, if the user is leaving an area, rather than wait for the auto-shutoff timer to expire, an OFF push button on the unit may be pressed to send an OFF control message to the wireless light bulb or battery powered wireless lighting fixture to shut the light off. In some examples, the motion sensor may be briefly disabled for some period of time to allow the user to leave the area such that their motion when exiting does not retrigger the light immediately. For example, if the motion sensor is disabled for five seconds after the OFF push button is pressed, the user may be able to exit the area without retriggering the light. This function may allow the user to save power consumption in the wireless light bulb or battery powered wireless lighting fixture by providing the means to turn the light off manually when they know it will not be used. In some

embodiments, the RF transmitter and motion sensor may mount to a bracket that can be mounted to a wall, ceiling, stake or the like such that the bracket may be articulated to allow the motion sensor to be pointed in the direction that the motion needs to be detected. This may allow the ability to optimize the area of detection given the characteristics of the motion detector and the desired area where motion is to be detected. In alternate embodiments, multiple motion detectors may be built into the same housing to allow motion to be detected from more than one direction. For example, a motion detector with three sensors each with 120 degree coverage may cover 360 degrees of motion detection allowing a stake or pole mount sensor to detect motion from any direction. This stake may be mounted in an open area to detect motion from any direction and turn on the light source to illuminate an area.

[0217] As shown in the illustrated embodiment, the wireless light bulb power source is alternating current (AC) typical of hard-wired fixtures that can provide AC power to light bulbs. The wireless light bulb includes AC circuitry, including an AC/DC converter to generate DC power for the circuitry and light source contained in the wireless light bulb. The AC/DC converter may include line capacitors, a diode bridge, a fly back converter, a constant current circuit, DC regulator and so on to convert AC power from the line to DC power. It will be understood that a variety of AD/DC converters are possible. In one known embodiment, a diode bridge, a constant current buck converter, a linear voltage regulator and protection circuitry are used to provide power to the control circuitry and light source.

[0218] In some embodiments the wireless light bulb may be powered directly from a DC input. In other embodiments the wireless light bulb can be powered off of a nominal 12V AC source. For example, an MR16 type wireless light bulb can be designed to take the 12V AC provided at the pin base and convert it to DC. In another example, the MR16 type wireless light bulb can include a full wave rectifier circuit to accept 12V AC or 12V DC input to power the circuitry and light source. It is appreciated that any AC or DC input can be converted to an operating power source for the circuitry and light source.

[0219] Wireless light bulbs powered from AC power with wireless control in the form of an embedded sensor or RF or IR receiver allow for individual wireless light bulbs on the same wired circuit to be controlled independently. In one example, individual wireless light bulbs with an embedded RF receiver and intelligence to process commands received over an RF communication link are on the same wired circuit and can be controlled by an RF wall switch. An RF transmitter circuit embedded in the wall switch can control individual bulbs on the wired circuit to turn them on or off, send dimming commands, program functionality to change state based on time of day, program on times, off times and brightness levels based on billing rates from the power company at different times of the day etc. The RF transmitter circuit may be combined with one or more other wireless control methods to implement additional functionality. For example, a motion sensor could be used in addition to the RF transmitter to control the light based on motion detection. The RF transmitter circuit can be battery powered and therefore offer the convenience of allowing it to be installed anywhere or the RF transmitter circuit can be part of an assembly that can replace or modify the wall light switch controlling the entire wired circuit to provide greater control of the lights on that wired

circuit. In the case where the wall light switch is replaced by an RF transmitter wall light switch assembly, the RF transmitter circuitry may be battery powered, but it also may use AC as its power source and thus contain an AC/DC circuit. In one example, the RF transmitter wall light switch assembly may use the existing on/off switch of the wall light switch (i.e. be installed inside the wall light switch) or in another example the assembly may be installed to replace the wall light switch altogether. In another example, motion sensor controlled wireless light bulbs on a wired circuit can be installed to conserve power by detecting occupancy and only turn on when the light is needed. All of the bulbs can be motion sensor wireless light bulbs or there can be a mix of motion sensor wireless light bulbs and traditional light bulbs to conserve power when the additional light is not needed. It is to be appreciated that any sensor described herein can be used to individually control wireless light bulbs on a wired circuit.

[0220] In another embodiment, the power source can be one or more batteries embedded in the wireless light bulb instead of AC power. For instance, the power source can be any number, size, and type of rechargeable (e.g., nickel-cadmium) and/or non-rechargeable (e.g., alkaline) batteries. Pursuant to a further illustration, the power source can be a solar cell. Moreover, the power source can be a combination of a solar cell and one or more batteries. Thus, for instance, a battery can supplement power supplied by the solar cell (or vice versa) and/or the solar cell can recharge a battery. In accordance with a further illustration, the power source can wirelessly obtain power (e.g., to be utilized directly, employed to recharge batteries); for instance, power can be wirelessly delivered to the power source via collecting RF energy from the environment, electromagnetic induction, wave coupling, converting motion or heat to electrical energy, wireless power transmission, and the like. It is to be appreciated that any wireless power source or any combination of wireless power sources can be used to supply power to or recharge energy storage in the wireless light bulb. For example, a wireless light bulb can contain circuitry to collect RF energy from the environment and also contain rechargeable batteries to store the collected energy. In alternate embodiments the power source may include a fuel cell, such as and without limitation a hydrogen fuel cell, a reformed methanol fuel cell, or the like. In other alternate embodiments, the power source may include a capacitor, array of capacitors, super capacitors to store energy to be used as a power source similar to a battery, and the like.

[0221] By way of an example, the wireless light bulb can physically couple with a fixture to support the wireless light bulb in a particular position, yet electrical current need not flow between the fixture and the wireless light bulb. Thus, the fixture can be installed at substantially any location without needing to supply power (e.g., via hard-wiring the fixture); hence, the fixture can be physically placed, secured, mounted, installed, etc. in a locale without being hard-wired to a power source. A battery powered wireless light bulb allows for a fixture to be installed anywhere. Any type of fixture design (size, shape, style etc.) can be installed at any location suitable for installation of the fixture and using a battery embedded wireless light bulb it can be done without the need for wiring. Power is embedded in the bulb and control is provided by a sensor and/or RF/IR receiver that is also embedded in the bulb. As another example, the battery embedded wireless light bulb allows for a lamp (table lamp, floor lamp, desk lamp etc.) to be placed anywhere independent of a need to be placed close to

an electrical outlet, using an extension cord to cable power to the lamp or having an electrician wire power to a point where the lamp can be plugged into an AC power source. Alternately, a battery powered wireless light bulb can be used in an existing fixture or lamp to take advantage of wireless power and wireless control in that location. In an alternate embodiment, to use the switch control on the lamp that would control on and off when plugged into an AC socket, the lamp remains unplugged, however an electrically conducting cap or connector is placed on the end between the two AC prongs of the connector to short the two prongs together. Inside the wireless light bulb, a short circuit can be detected. When detected as a short circuit, the switch control is in the on position and the battery powered wireless light bulb is turned on. When it is detected as an open circuit, the switch is in the off position and the battery powered wireless light bulb is turned off.

[0222] In another example, a motion sensor wireless light bulb powered only by embedded batteries can replace one or more incandescent light bulbs on a wired circuit. By way of an example, there are six recessed fixtures containing six R30 incandescent bulbs controlled by a single wall switch. One of the incandescent bulbs is replaced by an R30 motion sensor wireless light bulb powered only by embedded batteries or one of the incandescent bulbs is replaced by a recessed fixture motion sensor wireless light bulb that mechanically replaces the entire recessed fixture and is powered only by embedded batteries. There are several advantages to this use scenario for the battery embedded wireless light bulb. First, the motion sensor wireless light bulb will work even in a power outage so it offers an emergency or safety lighting function. Second, even when the wall switch is turned off and the incandescent bulbs are off, the motion sensor wireless light bulb will still provide enough light when motion is detected to find a path to the wall switch to activate all of the lights. Third, there may be enough light from the motion sensor wireless light bulb such that the additional lighting is not necessary therefore the incandescent bulbs would not be used. This provides some savings in power consumption as well as a dim light level which may be preferable sometimes to the bright light offered by too much lighting in an area. In an alternate embodiment, the motion sensor wireless light bulb can have multiple light levels. For example, it can have a bright light level but revert to a glow or low light level when the timer reaches a predetermined threshold to conserve energy but also provide a low level of light until motion is detected to turn on to the bright light level. In an alternate embodiment, logic can maintain the bright light level for some period of time, but then can control the light to fade to a glow or low light level by slowly dimming the at least one LED through pulse width modulation or other brightness control method over some preset or programmable period of time until it reaches the glow or low light level. In an alternate embodiment, a light sensor may provide a measurement of the ambient light level to set the light intensity level for a daylight harvesting function where the light intensity is set based on the ambient light level detected such that the ambient light plus the light generated by the light source maintain a constant light level.

[0223] By way of another example, the one replacement wireless light bulb contains an RF receiver and can be controlled by RF via a remote control. The remote control can be kept in a convenient location, a bedside table for example, to turn on the replacement bulb that would provide enough light to get to the wall switch to turn on the brighter incandescent lights or it could turn on one or more RF controlled battery

embedded wireless light bulbs that provide adequate light. Alternatively, the battery embedded wireless light bulb can be controlled by any combination of RF, IR, or any sensors mentioned herein.

[0224] In other embodiments, the battery powered wireless light bulb will contain rechargeable batteries such that the bulb can be recharged by connecting the bulb to an AC power source such as plugging the bulb into a recharging base, plugging the bulb into an AC light socket and the like. For example, a battery powered wireless light bulb containing rechargeable batteries can be used with a fixture or lamp. When the capacity of the rechargeable batteries dips below a level that the light output is no longer acceptable, a user can unscrew the battery powered wireless light bulb and screw it into a recharging base. The recharging base is comprised of the circuitry necessary to charge the batteries to capacity. When battery charging is complete, the user can remove the bulb from the recharging base and return it to the fixture or lamp. In another example, the bulb can be plugged into a standard light socket to charge the batteries. In one embodiment, the bulb can also be connected to a DC power source for recharging and as such would have circuitry to make use of the DC power source for recharging the batteries. In an alternate embodiment, the bulb has a USB connector on it that allows for charging by connection to a USB port. In other alternate embodiments any form of wireless power mentioned herein may be used for recharging a battery powered wireless light bulb. It is to be appreciated that any combination of charging approaches can be included in the same battery powered wireless light bulb.

[0225] In such a case when there is a USB connector on the bulb, the USB connector may also be used as a communication interface to program the bulb. An AC powered wireless light bulb or battery powered wireless light bulb may be able to attach to a computer via USB directly or over a USB cable to connect the bulb for programming. In other embodiments, different interface types on the bulb such as Ethernet, IEEE 1394 Fire Wire, Serial Port or the like can be used to connect to a computer directly or by cable to program the bulb. In another example, a programming adapter connected to the computer that the wireless light bulb can plug into or connect to electrically and mechanically in any known manner may serve as the interface to program the bulb. In other embodiments, an RF or IR adapter that can plug into a computer directly or via a cable using any of the interface types listed may send programming information to one or more wireless light bulbs containing an RF or IR receiver or transceiver to program the wireless light bulbs. In some embodiments, an RF or IR interface to the wireless light bulb may be provided by any device (remote control, keypad, PDA, computer, laptop, custom circuit etc.) with the RF or IR interface and the ability to communicate with the wireless light bulbs can be used to program the wireless light bulbs. A software program that allows a user to set the state of the bulb based on timer or time of day, auto shut-off times, color temperature, light strength (glow levels, low light levels, dimming/fading functions), motion sensitivity and listening on times, light sensitivity, level of ambient light controlled by a photocell, energy usage control to control light output based on a desired amount of energy usage over time, network parameters (unique IDs, network IDs, multicast IDs, broadcast IDs, IP address, routing and forwarding information for the network, WIFI SSIDs, ZIGBEE PAN IDs and network IDs, X10 four bit house code, INSTEON address or the like), sensor param-

eters (detection thresholds for setting the state of the bulb, timer and time of day settings for when the sensor is active and the like) etc. is used to connect to and program the state of the bulb. It is to be appreciated that the AC powered or battery powered wireless light bulb may contain the intelligence necessary to implement the programmable functions.

[0226] Batteries in a battery powered wireless light bulb can also be removable and replaceable. In one embodiment, the bulb may have a battery compartment with a cover that can be removed to access the batteries. In an alternate embodiment, the bulb may have batteries that are accessible by unscrewing the top of the bulb and removing an assembly that contains the circuitry, light source and a battery holder containing the batteries. In an alternate embodiment, the bulb may be a recessed fixture wireless light bulb with the ability to remove and replace the exposed face of the recessed fixture to access of battery holder inside the fixture. Alternate embodiments may include but are not limited to any known method of accessing a wireless light bulb to remove and replace the batteries. The batteries can be non-rechargeable batteries that can be replaced or removed or can be rechargeable batteries that can be removed and recharged when capacity drops below a usable level then returned to the bulb. The non-rechargeable or rechargeable batteries also can be embedded in the bulb permanently with no method for removal and replacement.

[0227] According to another illustration, a light socket or fixture can provide AC power that can be leveraged by the wireless light bulb in addition to one or more alternate power sources embedded in the wireless light bulb. The alternate power sources can be non-rechargeable or rechargeable batteries, solar cell, fuel cell (such as and without limitation a hydrogen fuel cell, a reformed methanol fuel cell, or the like), collecting RF energy from the environment, electromagnetic induction, wave coupling, converting motion or heat to electrical energy, wireless power transmission, capacitors and any other form of wireless power mentioned herein. It is to be appreciated that the AC powered with alternate power source wireless light bulb can contain the intelligence and control circuitry necessary to make use of any disparate wireless power source or sources in addition to or instead of the AC power source. It is to be appreciated that the AC powered with alternate power source wireless light bulb can be in the form of any bulb type, fixture, down light assembly, and the like, such as mentioned herein.

[0228] In one embodiment, rechargeable or non-rechargeable batteries are embedded into the wireless light bulb such that the light source and control circuitry can use either the AC power source or the embedded battery power source. In one example, there is circuitry inside the wireless light bulb that may detect that AC power is no longer present (power failure) or some other characteristic that makes AC power no longer desirable to use (brownout conditions, electrical surges, over-voltage conditions, voltage sag or flickers, line noise, frequency variations, switching transients, harmonic distortion etc.) at the light socket, fixture or down light assembly. In this case the wireless light bulb can switch over to battery power automatically to power the control circuitry and light source. This application, the uninterruptable power supply light bulb, or UPS light bulb, provides emergency or safety lighting during a power outage. Additional intelligence may be designed into the UPS light bulb to provide features or extend the amount of time usable light may be available when powered by the embedded battery power source. The UPS light

bulb may contain a colored LED that blinks when the battery source is being used to provide an indication that the UPS light bulb is being powered by the embedded battery source. In some embodiments, the UPS light bulb may contain intelligence to detect the battery capacity level and adjust the light intensity level to extend the amount of time there is usable light out of the UPS light bulb. This may take advantage of the characteristic of batteries that at lower continuous current levels the rate of battery drain will be lower. By way of an example, if there is a short power outage, the initial light intensity level may be a high level, however after some amount of battery drain over some period of time, the light intensity level may be dropped to a lower level requiring less continuous current from the batteries, extending the amount of time the light source may run on batteries (anticipating that the power outage may last a long period of time). It is to be appreciated that any number of light intensity levels may be set based on any number of detected battery capacity levels. In alternate embodiments, the change in light intensity level may be controlled by time (timer, time of day clock etc) instead of monitoring battery capacity levels. In such a case, the UPS bulb may contain intelligence to use the timer or time source and adjust the light intensity level to extend the amount of time there is usable light out of the UPS light bulb. In an alternate embodiment, a light sensor may be present in the UPS light bulb to sense the amount of ambient light present and adjust the light intensity appropriately. In this embodiment, the light sensor may extend the amount of time there is usable light when the embedded battery power source is used by optimizing the amount of light output based on the detected light level. Using the light sensor to set the output light intensity may optimize the drain on the embedded battery power source. In alternate embodiments, the UPS light bulb contains one or more methods of wireless control that may be used to provide additional functionality. By way of an example, a motion sensor may be added to the bulb such that it will only operate when motion is detected. By way of another example, the UPS light bulb may contain a receiver to allow a remote control to turn it on, off, change light intensity, select the power source (allowing the UPS light bulb to be turned on or off independent of AC power) or control any feature that may be present the UPS light bulb. The UPS bulb may use a sensor as an alarm indication and in some cases use that sensor information to select the power source. By way of an example, a thermal sensor may detect heat and when the temperature level rises above a threshold it may cause the UPS bulb to switch to battery power and blink the light source in a way to indicate an alarm situation. In alternate embodiments of the UPS bulb or any wireless light bulb, they may contain one or more thermal sensors and be able to transmit via an RF or IR transmitter temperature information back to a thermostat or any device that may display or make use of temperature information in any way.

[0229] The UPS light bulb may include circuitry to detect at the UPS light bulb conditions that may allow an intelligent decision on which power source to use. The UPS light bulb may need to detect whether the controlling switch or breaker applying power to the UPS light bulb is open or closed, if input AC power is present, if the quality of the input AC power is acceptable, and the like. The UPS light bulb may monitor the presence and quality of the input AC power with circuitry in the bulb to detect the presence of AC power and make a measurement of the characteristics of the AC power. It may also measure the impedance, resistance, and/or capacitance

across the AC power input and return or may measure any other electrical characteristic of the AC power input and return to determine whether the controlling switch or breaker is open or closed (or if electricity has been turned off at any point up to the AC input of the UPS light bulb). By way of an example, if the controlling switch or breaker is open, there may be a high impedance detected across the input AC power and return. If the controlling switch or breaker is closed, there may be a measureable impedance, resistance and/or capacitance or electrical characteristic different from when the controlling switch or breaker is open. A threshold may be set in the bulb such that if the measurement is above or below the threshold, the switch or breaker is closed, and if the measurement is on the opposite side of the threshold, the switch or breaker is open. The UPS light bulb may be controlled by the state of the controlling switch or breaker (on or off), but may also detect the condition when the controlling switch or breaker is closed but AC input power is not present or is not acceptable and may be able to switch over to the rechargeable or non-rechargeable batteries that are embedded as the power source. Thus, the UPS light bulb may be able to switch to embedded battery power without directly knowing whether the switch is open or close, but rather by measuring the electrical characteristics of the AC input. In some embodiments, the UPS bulb may have circuitry to be able to detect the switch transition from on to off or off to on. By way of an example, in a power outage, the wall switch may still be used to control the UPS bulb that is powered by battery to on or off such that even when AC is not applied, a transition from switch closed to switch open will turn off the UPS bulb that is powered by the embedded power source.

[0230] In some embodiments, the UPS light bulb may perform an impedance discontinuity check to determine if the controlling switch or breaker is open or closed. In some embodiments, the UPS light bulb may generate a signal onto the line and monitor the electrical response of the line to determine if the response indicates an impedance discontinuity typical of an open circuit that may be indicative of a switch or breaker open in the lighting circuit or if the response indicates a closed circuit typical of a switch or breaker closed in the lighting circuit. By way of an example, the UPS bulb may perform a function typical of a time domain reflectometer by generating a short rise time pulse at the connection to input and monitor the input for a reflected signal that would be indicative of an open or closed circuit. If the reflected signal exceeds a set threshold, it may indicate an open circuit. In some embodiments, the UPS bulb may need to learn where such a threshold should be set. The UPS bulb may be installed in many variations of lighting circuits where the amount, length, gauge or type of wiring to the switch or breaker may vary and where there may be many other sources of loads on the lighting circuit (such as other bulbs, multiple switches or controls etc.) therefore it may have to adjust its detection circuitry to operate properly. It is to be appreciated that the setting of the threshold may be done automatically by the UPS bulb or manually by a user through any process that may allow the bulb to be set to a threshold where one side of the threshold indicates the switch or breaker is open and the other side of the threshold indicates the switch or breaker is closed. It is to be appreciated that when the switch sense functionality is implemented, the switch or breaker may still be able to turn on and off power to the UPS light bulb or wireless light bulb even when running off of the embedded battery power source because the UPS light bulb or wireless light bulb may be able

to determine if the switch is on or off and apply power or not apply power to the UPS light bulb or wireless light bulb based on the switch position. In such a case, the switch sense circuitry may still need to be powered along with any other necessary circuitry to implement this function even when the light source is not being powered.

[0231] In some embodiments the UPS bulb may be removed from the socket such that it may be carried around as a light source. As such the UPS bulb may detect a different set of electrical characteristics of the AC input of the UPS bulb when it is removed from the socket. Alternatively, the UPS bulb may be able to detect the switch transition from on to off, off to on or be able to detect that neither transition happened but there was a change in the electrical characteristics and as such determine that the bulb was removed from the socket. The removed bulb may become a “flashlight” when carried around by itself, plugged into a base unit that has a handle or handheld in any manner conceivable such that it can be carried around. The base unit may have a switch on it with a circuit connected to the socket where the UPS bulb plugs in and can detect electrical characteristics of the switch and circuit (similar to the measurement of impedance, resistance and/or capacitance mentioned herein) such that the switch may be used to turn the UPS bulb on and off. It is to be appreciated that the functionality described for the UPS light bulb may be designed in any size or shape housing to meet the requirements of any standard size bulb (e.g. PAR30, PAR38, A19, R30, MR16 etc), non-standard size bulb, fixture, compact fluorescent bulb, fluorescent bulb or lamp (e.g. T4, T5, T8, circular etc.) or down light assembly (e.g. recessed fixtures, fluorescent fixtures or down light fixtures for residential, commercial or industrial lighting), or the like.

[0232] In one embodiment where rechargeable batteries are the alternate power source, circuitry can also be present in the bulb to control the recharging of the batteries while AC power is applied (trickle charge, slow charge, fast charge etc.) and under what conditions the recharging will happen (time of day, battery capacity level, any time AC power is applied etc.). It is also to be appreciated that the batteries can be recharged through an alternate interface such as a USB connector or any form of wireless power on the wireless light bulb mentioned herein.

[0233] In such a case when there is a USB connector on the bulb, the USB connector may also be used as a communication interface to program the bulb. The AC powered battery embedded wireless light bulb can attach to a computer via USB directly or over a USB cable to connect the bulb for programming. In other embodiments, different interface types on the bulb such as Ethernet, IEEE 1394 Fire Wire, Serial Port or the like can be used to connect to a computer directly or by cable to program the bulb. In another example, a programming adapter connected to the computer that the wireless light bulb can plug into or connect to electrically and mechanically in any known manner may serve as the interface to program the bulb. In other embodiments, an RF or IR adapter that can plug into a computer directly or via a cable using any of the interface types listed may send programming information to one or more wireless light bulbs containing an RF or IR receiver or transceiver to program the wireless light bulbs. In some embodiments, an RF or IR interface to the wireless light bulb can be provided by any intelligent device (remote control, keypad, PDA, computer, laptop, custom circuit design etc.) with the RF or IR interface and the ability to communicate with the wireless light bulbs can be used to

program the wireless light bulbs. A software program or other device that allows a user to set the state of the bulb based on timer or time of day, auto shut-off times, color temperature, light strength (glow levels, low light levels, dimming/fading functions), motion sensitivity and listening on times, light sensitivity, level of ambient light controlled by a photocell, energy usage control to control light output based on a desired amount of energy usage over time, network parameters (unique IDs, network IDs, multicast IDs, broadcast IDs, IP address, routing and forwarding information for the network, WIFI SSIDs, ZIGBEE PAN IDs and network IDs, BLUETOOTH, X10 four bit house code, INSTEON address or the like), sensor parameters (detection thresholds for setting the state of the bulb, timer and time of day settings for when the sensor is active and the like) etc. is used to connect to and program the state of the bulb. It is to be appreciated that the AC powered battery embedded wireless light bulb may contain the intelligence necessary to implement the programmable functions.

[0234] In addition to controlling the lighting installation, the sensors and intelligence that are designed into wireless light bulbs and communication interface implemented in the wireless light bulbs may allow the wireless light bulbs installed to also perform functions in addition to lighting. This applies to AC powered, battery embedded, AC powered battery embedded or any combination of power source wireless light bulbs mentioned herein. The embedded sensors and intelligence together with the communication interface may allow a single wireless light bulb to implement functionality beyond just lighting. Multiple wireless light bulbs may form a sensor network to add useful functions to a lighting installation where multiple wireless light bulbs may be individually controlled or work as a network to implement one or more functions in addition to lighting. A software program or intelligent device may allow a user to gather status from a sensor in the wireless light bulb or from intelligence designed into the wireless light bulb over the communication interface such as but not limited to temperature, ambient light levels, battery capacity levels, energy usage statistics, on and off time records, sensor detection data and statistics (motion detections per some unit of time, switch actuation information to generate an alarm, smoke detector alarm signals etc.), network usage statistics or information that can be gathered from any sensor or intelligence built into the wireless light bulb. A software program or intelligent device may also receive a stream of data collected by a sensor of the wireless light bulb over the communication interface such as but not limited to audio from a microphone, a video stream from a camera, pictures from a digital camera, RFID tag read information (i.e. an RFID tag reader), etc. A software program or intelligent device may also control a device inside the wireless light bulb over the communication interface to implement any function such as but not limited to a speaker to make announcements or generate sound, a horn to generate alarms, enable a circuit to energize or de-energize a relay or other switch control, turn on or off a motor, etc.

[0235] In one use case, the design is a par30 motion sensor wireless light bulb or a 6" recessed fixture motion sensor wireless light bulb. They are installed in office space in 50 different locations in addition the lighting that is installed. Software running on a computer allows a security guard to communicate with and receive status from the wireless light bulbs. When a wireless light bulb detects motion, it sends a message to the security guard's computer that motion has

been detected and which bulb has detected the motion (i.e. the location where the motion is). The security guard receives a message or an alarm that motion has been detected in one of 50 locations which may provide an indication of a security issue or that someone is not where they are supposed to be. In some embodiments, a software application may send an e-mail, XML message or any other type of message to provide alerts to the end user based on the message received from a wireless light bulb or wireless lighting module. In some cases, a software application may store in memory or a database a record of the motion detections over time. In an alternate use case, the wireless light bulbs record a statistic called "number of motion detections since last read". A software application can read that statistic from each wireless light bulb and determine how to most efficiently use the lighting by time of day and usage profile. It can be used not only to control lighting but for occupancy studies in building management, used to record the flow of traffic past a certain point, and the like. In one possible use, the sensor may not control lighting, but is used for the information provided by the sensor in addition to the light that is used for illumination.

[0236] In another use case, the design is a recessed fixture RFID reader wireless light bulb. They are installed in office space in 50 different locations in addition the lighting that is installed. Employees and guests are issued identification, such as badges that are RFID tags or access cards that can be read by the RFID reader or the access card reader in the wireless light bulb. In addition, RFID tags can be attached to assets for operational efficiency and theft prevention. Software running on a computer receives the reads of the identifications badges or asset tags and can provide an indication of current or last known location within the building with respect to the location of the RFID reader wireless light bulbs. This provides the building manager the ability to find, track or review the real time or historical movements of employees, guests or assets. This functionality can be used for safety, security, operational efficiency, etc.

[0237] In another use case, a wireless light bulb has a speaker or alarm horn in it that allows announcements to be made (like an intercom system which could be two way if the units had a microphone on them also) or alarm sounds to be generated in certain emergency situations. In an alternate use case, a wireless light bulb is installed as a porch light with a microphone and speaker built in. A user can push a button on an intercom box inside of their house to talk or listen to a visitor through the porch light microphone and speaker.

[0238] In another use case, a wireless light bulb or battery powered wireless lighting fixture may have a motion sensor and RF transmitter in addition to the light source. When motion is detected, the light source may be turned on and an indication that motion was detected may be transmitted to an RF receiver. The RF receiver may be connected to an intelligent device such as a computer that may allow the motion indication to be interpreted. For example, in a health care application, a wireless light bulb or battery powered wireless light fixture may be installed in the bathroom of a hospital room or in the hallway of the hospital floor. When motion is detected in the bathroom or hallway, the light may be turned on and an indication that motion was detected may be received at the nurse's station. If there is a reason that a patient should not be moving, then that indication may be an alarm indication providing allowing the nurse to take action immediately. Unique IDs may be set in each of the wireless light bulbs or battery powered wireless lighting fixtures such that,

by knowing the location of the installed wireless light bulb or battery powered wireless lighting fixture, the location of the source of motion may be known.

[0239] Batteries in an AC powered battery embedded wireless light bulb can also be removable and replaceable. In one embodiment, the bulb may have a battery compartment with a cover that can be removed to access the batteries. In an alternate embodiment, the bulb may have batteries that are accessible by unscrewing the top of the bulb and removing an assembly that contains the circuitry, light source and a battery holder containing the batteries. In an alternate embodiment, the bulb is a recessed fixture wireless light bulb with the ability to remove and replace the exposed face of the recessed fixture to access of battery holder inside the fixture. Alternate embodiments may include but are not limited to any known method of accessing a wireless light bulb to remove and replace the batteries. The batteries can be non-rechargeable batteries that can be replaced or removed or can be rechargeable batteries that can be removed and recharged when capacity drops below a usable level then returned to the bulb. The non-rechargeable or rechargeable batteries also can be embedded in the bulb permanently with no method for removal and replacement.

[0240] In one embodiment, a PAR30 AC powered battery embedded wireless light bulb contains a single battery cell and a charge pump LED driver to generate the necessary drive voltage and current for the LED light source. In this example, the single battery cell is a NiMH rechargeable D cell battery. Using a single battery cell allows the design to fit within the design constraints of the PAR30 bulb type. It is to be appreciated that any number or type of battery can be used. A charging circuit that supports NiMH charging in circuit is also part of the electronics inside the bulb. There is also circuitry inside the bulb to allow each power source to be used independently or to share the load depending on whether each power source is present and able to supply power to the wireless light bulb. It is to be appreciated that any form of wireless control mentioned herein can be used in conjunction with this embodiment.

[0241] In an alternate example, the UPS light bulb also contains an RF receiver that allows the UPS light bulb to receive control commands over an RF communication link. In one example, an RF transmitter can be coupled with an AC detection circuit such that when it detects that AC power has dropped out (i.e. there is a power outage) or some other characteristic that makes AC power no longer desirable to use (brownout conditions, electrical surges, overvoltage conditions, voltage sag or flickers, line noise, frequency variations, switching transients, harmonic distortion, etc.) it will send a command to the UPS light bulb to switch it over to battery power. Upon detection that AC power is back on or is desirable to use, the RF transmitter can send a command to switch over to AC power. This power outage module in the form of an RF transmitter and AC detection circuitry in a housing can be designed to operate plugged into an electrical wall socket, hardwired into or as a replacement for an AC wall light switch to allow detection of the state of AC power prior to the switch independent of the on/off position of the wall switch, can be hardwired directly into a breaker box to determine the state of power where it enters a residence or building, can be wired into an emergency circuit and respond to an emergency on signal or can be wired into any point in a power distribution system that a user may want to detect a drop out in AC power. The RF transmitter and AC detection circuitry can be powered

off of AC power or powered by batteries. In addition to controlling a AC powered battery embedded wireless light bulb, it is to be appreciated that the RF transmitter and AC detection circuitry can control battery or AC powered fixtures that may not be wireless light bulbs, but rather stair lights, spotlights, path lights, exit signs and lighting, stair well lights, floor lights, ceiling lights etc to provide lighting in an emergency situation. It is to be appreciated that a network of wireless light bulbs and fixtures with RF transceivers may be created to propagate control messages through the network to control any installed lights from one or more RF transmitter and AC detection circuits. It is to be appreciated that any command can be sent as it relates to the state of AC power as detected by the detection circuitry. For example, to conserve energy or save money on an energy bill, the RF transmitter and AC detection circuitry may monitor power usage on a wired circuit and send a dimming command or a command to set the brightness of the lights on the wired circuit to a lower level when power usage exceeds some threshold, but at some later time send a second command returning the lights on the wired circuit to a brighter level thus allowing power usage on that wired circuit to stay below some average usage level. In some embodiments, the RF transmitter and AC detection circuitry contains circuitry to act as a load control switch receiving a load control command from the power company and transmitting to one or more wireless light bulbs to turn off, change light intensity, switch over all or a portion of the load to battery power etc. In alternate embodiments, the unit does not contain AC detection circuitry and is just a load control switch with an RF transmitter that may control the wireless light bulbs in an installation in a demand response energy efficiency system, for load control purposes and the like. This wireless lighting load control switch may contain a timer such that after it receives a command from the power company to change to a lower energy consumption state, the wireless lighting load control switch may start a timer and when the timer expires the wireless lighting load control switch will send a command returning to the original state of operation or to another state of operation.

[0242] In some embodiments the power outage module may be connected to an emergency lighting circuit such that if the emergency lighting circuit forces a switch to emergency lighting, the emergency lighting power outage module will detect the emergency lighting circuit turning on and will transmit a message to the UPS light bulbs, wireless light bulbs and battery powered wireless lighting fixtures to switch on or to some dedicated emergency lighting function. For example, the UPS light bulbs, wireless light bulbs and battery powered wireless lighting fixtures may switch to a lower light level when switched over to battery power in an emergency situation to extend battery life during the emergency. In another example, the UPS light bulbs, wireless light bulbs and battery powered wireless lighting fixtures may blink the lights to indicate the emergency situation.

[0243] In some embodiments, the power outage module may contain a light source such that in cases where it is detachable, it may be removed and used as a light source powered by batteries. In such a case, a user may detach the power outage module and walk around using it in a manner similar to a flashlight. In some embodiments, the RF transmitter and AC detector circuit may contain forms of wireless controls such as sensors to control the lights during a power outage but also in normal operation. By way of an example, a power outage module may work as described, but also contain

a motion sensor such that when motion is detected under normal circumstances, a control message is transmitted to the wireless light bulbs and wireless lighting modules within range to control them, but in a power outage situation would transmit a different control message. In alternate embodiments, sensors may be modules that plug into the power outage module. In such a case, the power outage module may contain a connector to allow a sensor module to be installed. By way of an example, a user may plug in a light sensor module such that a measurement of the amount of ambient light detected by the light sensor may be transmitted to the wireless light bulbs and wireless lighting modules. It is to be appreciated that the sensor may be plugged in permanently or plugged in temporarily. In the example using the light sensor module, the light sensor module may be used to make a one-time measurement of ambient light in an area to adjust the light, then removed or it may be permanently installed to allow the wireless light bulbs and wireless lighting modules to continuously adjust light intensity to match the ambient light detected to maintain some net light level. In some embodiments, the power outage module may send any type of message to control the wireless light bulbs and wireless lighting modules to achieve any functionality mentioned herein. By way of an example, the power outage module may send a message setting the light intensity level, programming an auto shutoff time, changing the way the controlled lights manage power and the like. It is to be appreciated that the power outage module may control UPS light bulbs, wireless light bulbs with integrated power sources, battery powered wireless lighting fixtures etc.

[0244] In some embodiments the power outage module may be a removable module and may act as a remote control such that a user may be able to remove the module or a part of the module from where it is installed and walk around with a remote control to control the wireless light bulbs and battery powered wireless lighting fixtures. In such an embodiment, the remote control power outage module may have button, switches, dials and the like to allow it to select and control lights on, off, the light intensity level etc. In some embodiments, the remote control power outage module may have an LCD touch screen or the like that would allow the user to control the lighting. In some cases, the remote control power outage module may be a control panel mounted to a wall that monitors the AC input and allows a user to control the lighting installation. In one embodiment, the power outage module remains in place, but an alternate remote control may be used to control the lighting. By way of an example, an IPHONE running an application and with a communication interface that may communicate with the wireless light bulbs and wireless lighting modules may allow control of the lights. It is to be appreciated that the remote control may use any communication interface and may contain any type of control mentioned herein. In some embodiments, the remote control power outage module or any other remote control mentioned herein may automatically detect when a bulb or fixture has been powered on.

[0245] In some embodiments, a power outage module may contain wireless power source such as a battery. Thus, the power outage module may be able to continue operation in the absence of AC power. The power outage module may draw its power from AC, its embedded wireless power source or both. It is to be appreciated that the power outage module will contain the circuitry and/or intelligence to manage which power source to use. In alternate embodiments, the power

outage module may not contain an embedded wireless power source. In this embodiment, the power outage module may send regular messages (“keep alive”) to the wireless light bulbs and wireless lighting modules such that as long as the wireless lights continue to receive the messages on a regular interval, the wireless lights should continue to operate normally. If the power outage module detects a problem with the AC power or its AC power is no longer present (i.e. it shuts off and hence stops transmitting), the wireless light bulbs and wireless lighting modules will not receive these keep alive messages from the power outage module for some period of time and as such determine that there is a problem with detected AC power and change state as necessary. By way of an example, the wireless light bulbs and wireless lighting modules may switch to an emergency mode and change their behavior in some way. Using a mechanism such that the wireless light bulbs and wireless lighting modules are required to hear the transmission of the power outage module at regular intervals prevents the case where the power outage module is disabled or blocked from transmitting in an emergency situation.

[0246] In another embodiment, the AC powered battery embedded wireless light bulb can be controlled by a motion sensor. It may or may not also be controlled by a light sensor to enable operation only in a low level of ambient light. The batteries can be rechargeable or non-rechargeable. The motion sensor controls the AC powered battery embedded wireless light bulb such that when motion has not been detected, the light source is set to a glow or a low light level powered by the embedded batteries. When motion is detected and a brighter light is required, the light will be turned on powered by the AC power source and it will be turned on to a bright level. The motion sensor can be powered by the batteries or by the AC power source. In one embodiment, the AC powered battery embedded wireless light bulb can work even when the AC power switch is off. For example, at night the AC wall light switch can be turned off, but the motion sensor and light source will still work using the embedded batteries as a power source. By way of an example, an R30 type AC powered battery embedded wireless light bulb can be controlled by motion sensor or by the wall switch with the light source powered by AC when AC power is applied and can be controlled by a motion sensor with the light source powered by the batteries when AC power is not present. The motion sensor is powered by the batteries in this example. In another example, the motion circuitry and low level light are powered by battery power, but when AC is applied, the light is set to its bright level independent of the motion sensor.

[0247] In an alternate embodiment, the AC powered battery embedded wireless light bulb can have multiple light levels that are controlled by the motion sensor. For example, it can have a bright light level but revert to a glow or low light level when the timer reaches a predetermined threshold to conserve energy but also provide a low level of light until motion is detected to turn on to the bright light level. In an alternate embodiment, logic can maintain the bright light level for some period of time, but then can control the light to fade to a glow or low light level by slowly dimming the light source over some preset or programmable period of time until it reaches the glow or low light level. In another alternate embodiment, the motion sensor can control the bulb if it is operating using the AC power source or if it is operating using the embedded battery power source. For example, there are two operational modes. First, if AC power is on the motion

sensor and associated logic controls whether the light source is on or off and what brightness level it is on at. Second, if AC is off, the motion sensor operates with the light powered by the battery power source. The brightness level may or may not be different whether power is from the AC source or the battery source.

[0248] In another embodiment, the AC powered battery embedded wireless light bulb can be controlled by RF or IR. Thus, the input component can be an RF or IR receiver that can obtain an RF or IR signal communicated from an RF or IR transmitter that can be utilized by logic inside the bulb to control operation of the light source. The RF or IR transmitter can come in the form of remote control, keyfob, wall switch or any other controller that can house the RF or IR circuitry and user control mechanism. According to this example, the RF or IR signal can be deciphered by the input component to effectuate switching the light source to an on or off state, changing a light color or a light intensity, and the like. By way of an example, dimming commands can be sent to control the AC powered battery embedded wireless light bulb to specific levels in response to commands received from the RF or IR transmitter in a remote control or wall switch. Controls (switches, push buttons, dials, control wheel, etc) on a remote control or wall switch can increase or decrease the light level, set the level to glow, low or high light level directly etc. The wireless light bulb can be commanded to use AC power, battery power, switch from on to the other at various times as set by timers, time of day or sunrise/sunset calendar information maintained by intelligence in the bulb, can be commanded to switch over when an AC outage is detected, can be commanded to energy conservation modes automatically switching to different light levels upon any detectable state of the power or controls of the bulb etc. By way of an example, a PAR38 type AC powered battery embedded wireless light bulb can be controlled by RF or IR or by the wall switch with the light source powered by AC when AC power is applied and can be controlled by RF or IR with the light source powered by the batteries when AC power is not present.

[0249] Additionally or alternatively, the input component of the AC powered battery embedded wireless light bulb can be one or more sensors that monitor a condition, and monitored information yielded by such sensor(s) can be utilized to effectuate adjustments associated with the light source and the selection of which power source to use and under what conditions. It is to be appreciated that any type of sensor(s) can be utilized in connection with the claimed subject matter. For example, the sensor(s) can be one or more of infrared sensors, light sensors, proximity sensors, magnetic switch sensor, acoustic sensors, voice activated sensor, motion sensors, radar sensors, sonar sensors, carbon monoxide and/or smoke detectors, thermal sensors, electromagnetic sensors, mechanical sensors, chemical sensors, pressure sensor, RFID tag reader or detection circuit and the like. According to another example, the input component can be a connector, port, etc. that couples to a disparate device, sensor, etc. to receive the input signal. It is also appreciated that any combination of RF, IR, motion or the sensors listed herein can be utilized in connection with the claimed subject matter. It is also appreciated that the light (off, glow, on at low level, on at bright level etc) and the transition between light levels can be controlled by any detectable state of the sensor or sensors. It is also to be appreciated that intelligence in the form of logic, electrical circuitry, microcontrollers, microprocessors, memory devices etc. contained in the bulb can leverage the

sensors to monitor patterns of RF, IR or sensor inputs, keep the patterns in memory over time if necessary and adjust individual lights based on the pattern. Thus the AC powered battery embedded wireless light bulb has the ability to learn from inputs from its environment and change behavior accordingly.

[0250] In an alternate embodiment, the wireless light bulb can take commands from a communication interface from an external source by wired connection over a power distribution network, for example on the AC power lines (X10, INSTEON, Broadband over Power Lines, proprietary communication scheme etc), or wirelessly through a wireless interface (dedicated RF communication link, ZIGBEE, WIFI, ENOCEAN, BLUETOOTH etc). For example, the electric company can control or gather status from AC powered battery embedded wireless light bulbs throughout its power distribution network to remotely offload power usage at times when power demand is high by commanding some portion or the entire distributed network of wireless light bulbs to switchover to battery backup. Rechargeable batteries can be charged for some period of time to store power when power usage is off peak, then be used to off load some of the demand by supplying power for the bulb when power usage is on peak. Non-rechargeable batteries can also be used for emergency power requirements. In an alternate example, the control of wireless light bulbs can be local in a residence or commercial building through a central source controlling building lighting to optimize energy consumption. The control and gathering of status may be done by an intelligent electrical meter, smart meter, and the like. In such a case the meter may directly communicate with one or more wireless light bulbs over an appropriate communication interface using a protocol that allows the wireless light bulbs and meter to exchange information. By way of an example, the wireless light bulb may measure the amount of power consumed over a period of time and an intelligent electrical meter, smart meter, a remote device, and the like, through an intelligent electrical meter, smart meter, and the like (for example via the smart grid), may retrieve that information to provide that information for any purpose. In another example, an intelligent electrical meter, smart meter, a remote device, and the like, through an intelligent electrical meter, smart meter, and the like, may control the wireless light bulb to turn it on, off, set the light intensity level, control which power source or sources are used (battery, AC and/or a wireless power source), retrieve any information from a wireless light bulb or control any sensor or intelligence present in a wireless light bulb in the lighting installation. In addition to controlling a switchover to battery power, other applications are possible. Information or a record of usage can also be stored and retrieved. The stored data may pertain to power usage however it may also pertain to sensor gathered information. For example, the bulb can contain an occupancy sensor, like a motion sensor, that can record times and levels of occupancy in an area that can later be retrieved.

[0251] In embodiments, a building management unit in the form of a separate piece of equipment may communicate with the installed wireless light bulbs with existing power lines, tapping onto existing power lines or through a wireless interface such as a dedicated RF communication interface in residential or commercial buildings. This unit may send commands using one of the possible communication interfaces such that wireless light bulbs in the lighting installation can be programmed, controlled, and information or status can be

retrieved for energy control and conservation, emergency functions, for safety and security, for convenience and any other functionality desired by a user. The building management unit may be controlled to implement the desired functionality via any method mentioned herein. By way of an example, the building manager unit with an RF communication interface may communicate to a network of wireless light bulbs that allows it to communicate with any wireless light bulb in the network. The unit may also have an Ethernet interface on the unit and have an IP address assigned to the interface. A software program running on the unit may allow a user to open a web browser and type in the IP address assigned to the unit. A graphical user interface served by the building management unit may open up providing a method for the user to implement the desired functionality. The building management unit may communicate with an intelligent electrical meter, smart meter, and the like, over an appropriate communication interface using a protocol that allows the building management unit, which controls the installation of wireless light bulbs, and meter to exchange information. For example, the building management unit may communicate over a communication interface with an intelligent electrical meter, smart meter and the like by wired connection over a power distribution network, for example on the AC power lines (X10, INSTEON, Broadband over Power Lines, proprietary communication scheme etc), or wirelessly through a wireless interface (dedicated RF communication link, ZIGBEE, Wi-Fi, ENOCEAN, BLUETOOTH etc). By way of an example, the building management unit may measure the amount of power consumed over a period of time and an intelligent electrical meter, smart meter, a remote device, and the like, through an intelligent electrical meter, smart meter, and the like (for example via the smart grid), may retrieve that information to provide that information for any purpose. In another example, an intelligent electrical meter, smart meter, a remote device, and the like, through an intelligent electrical meter, smart meter, and the like, may control the building management unit to control the lighting installation to turn lights on, off, set the light intensity level, control which power source or sources are used (battery, AC and/or a wireless power source), retrieve any information from the wireless light bulbs in the lighting installation or control any sensor or intelligence present in the wireless light bulbs in the lighting installation.

[0252] In an alternate embodiment, a lighting circuit control unit may be attached to one or more electrical circuits within a residential or commercial building and implement building management unit functionality on the circuit or circuits it is connected to. The lighting circuit control unit may attach electrically to the circuit at any point or communicate through an RF or IR communication interface. It may come in any form that allows it to use those communication interfaces. For example, it can be an RF transceiver with keypad, a hard wired box etc. retrofit into the wall switch, connected elsewhere in the circuit or as a standalone unit. The unit can control all wireless light bulbs it can communicate with or through a network of wireless light bulbs for energy control and conservation, emergency functions, for safety and security, for convenience and any other functionality as desired by a user based on an input from a sensor, time of day clock, human input, etc. Unique or group IDs may be assigned to multiple circuits, individual circuits or individual wireless light bulbs such that a user can control the lighting installation one wireless light bulbs, distinct groups of wireless light

bulbs or the entire lighting installation from one or more lighting circuit control units. By way of an example, a wall switch is retrofit with a lighting circuit control unit that is electrically inserted in line with AC power to a lighting circuit consisting of six R30 AC powered battery backed wireless light bulbs inserted into recessed fixtures. The lighting circuit control unit has an LCD display and push buttons that allow a user to scroll through a list of configuration items that can program the wireless light bulbs or a list of status that can be gathered from the lighting circuit working much like a thermostat for the lighting installation. The lighting circuit control unit communicates with the wireless light bulbs using a proprietary communication over power lines method to implement the functionality set by the user. The lighting circuit control unit may communicate with a smart meter over an appropriate communication interface using a protocol that allows the lighting circuit control unit, which controls the installation of wireless light bulbs, and meter to exchange information. For example, the lighting circuit control unit may communicate over a communication interface with an intelligent electrical meter, smart meter and the like by wired connection over a power distribution network, for example on the AC power lines (X10, INSTEON, Broadband over Power Lines, proprietary communication scheme etc), or wirelessly through a wireless interface (dedicated RF communication link, ZIGBEE, Wi-Fi, ENOCEAN, BLUETOOTH etc). By way of an example, the lighting circuit control unit may measure the amount of power consumed over a period of time and an intelligent electrical meter, smart meter, a remote device, and the like, through an intelligent electrical meter, smart meter, and the like (for example via the smart grid), may retrieve that information to provide that information for any purpose. In another example, an intelligent electrical meter, smart meter, a remote device, and the like, through an intelligent electrical meter, smart meter, and the like, may control the lighting circuit control unit to control the lighting circuit to turn lights on, off, set the light intensity level, control which power source or sources are used (battery, AC and/or a wireless power source), retrieve any information from the wireless light bulbs on the lighting circuit or control any sensor or intelligence present in the wireless light bulbs on the lighting circuit.

[0253] In an alternate embodiment, a direct personal control ability exists such that a user may control one or more wireless light bulbs and wireless lighting modules from their computer, handheld, remote control etc. In such a case, there may be a building management unit or larger software control system in place, but direct personal control may allow a user direct control of the lighting that affects that user. It is to be appreciated that the building management unit or larger software control system may contain the intelligence to identify that a user locally changed the configuration and update its configuration appropriately or notify a system administrator of the change implemented locally. The direct personal control ability may allow a user to configure one light or a group of lights to implement a coordinated function. By way of an example, an employee in an office may have a software application running on their computer and an adapter connected to the computer that allows the software application to communicate with the group of lights associated with the employee office and the hallway outside of the employee office. That employee has knowledge of when they will be in their office and when they will not. They may arrive early and leave early during the day, have multiple meetings such that they will not

be in the office and so forth. That employee may also have preferences for the lighting in their office. The employee may use the software application to configure the wireless light bulbs and wireless lighting modules in their office and hallway outside of their office for any of the functionality offered by the wireless light bulbs and wireless lighting modules. In this case, the direct personal control system may be implemented using the communication interface from the computer on the employee's desk to the wireless light bulbs and wireless lighting modules. Because the intelligence in the wireless light bulbs and wireless lighting modules is distributed, the employee may configure the units locally no matter what the state of the larger system is.

[0254] In embodiments containing a coordinated lighting group, there may be individually addressable lights as well as groups of lights (multicast and broadcast groups). Thus, a light may need to have multiple addresses assigned to it and as such may need to respond to control and return status based on every address assigned to it whether it is an individual address or group address. It is also to be appreciated that multiple individual addresses may be assigned to the same light such that the controlling sources may use different addresses to communicate with a light. By way of an example, direct personal control coming from a user's computer may communicate with a light on a different address than the building management system. This may be done so that there are different levels of access to the bulb from a security perspective. The system administrator may have access to more functionality than the user therefore multiple addresses may be used to define privileges. In some embodiments, a light may listen to commands intended for another lights and respond accordingly. By way of an example, a light may be the master and the other lights in a coordinated lighting group may be slaves. When the master is commanded to implement a daylight harvesting change, for example it is commanded to change its light intensity based on a new configuration, the slave lights may receive that command. After some period of time when the master has completed adjusting its light intensity change, the slave lights will then change their light intensity to also implement the daylight harvesting change. In this manner, the lights may gracefully implement daylight harvesting in a sequence that they will not be adjusting against each other.

[0255] In another embodiment, the AC powered battery embedded wireless light bulb contains rechargeable batteries. The light source can be powered by AC power, battery power or both. For example, power to the light source can be diode or-ed such that AC power and battery power share the load. The battery power can be charged all of the time or can contain the intelligence to be programmed to charge only when billing rates from the electric company are low. The sharing of the load between AC power and battery power given that the batteries will charge at least some of the time at off peak billing rates from the electric company and the light source will be on for at least some of the time that billing rates are higher or at their peak will result in energy savings and conservation. The bulb can contain the intelligence (micro-controller, microprocessor, real time clock etc.) such that it can be programmed to charge the battery power at the times when the billing rates are at their lowest the energy savings and conservation can be maximized. Thus, the AC powered battery embedded wireless light bulb has the ability of "moving power in time" by storing power at some time and using the power at another time. The AC powered battery embedded

bulb may or may not contain a sensor to control operation. The intelligence may use a real time clock and be programmed to use the AC input and charge the batteries during off peak billing times and use battery power during on peak billing times such that there is an overall cost savings in energy usage. By way of an example, the AC powered battery embedded bulb may be programmed for operation based on a Time of Use (TOU) price plan from the energy company. The rechargeable battery capacity may or may not be enough to power the light source for the entire duration of the on peak billing time. In such a case, the intelligence may be able to switch between power sources or control a sharing of the load between battery power and AC input power based on a measurement of battery capacity level, power use from the embedded batteries and from the AC input or any other measurable parameter that allows for an optimization for cost or minimize power consumption of the combined use of embedded batteries and AC input power.

[0256] In embodiments, the electric company may implement load shedding or load leveling using AC powered battery embedded wireless light bulbs, building management units and/or lighting control units throughout its power distribution network by remotely offloading power usage at times when power demand is high by commanding some portion or the entire distributed network of wireless light bulbs to switchover to battery power. In some embodiments, the wireless light bulbs, building management units and/or lighting control units may receive a load control signal from the electric company or end user to implement load shedding. The control may force a reduction in power consumption from the AC input by either reducing power usage (by dimming light levels for example) or by switching some portion of or all of the power source to battery power. In some embodiments, the wireless light bulbs, building management units and/or lighting control units may respond to supply conditions to implement demand response during peak or critical times or based on market prices by adjusting usage or by switching some portion or all of the power source to battery power. In some embodiments, load shedding or demand response may happen without an explicit command from the electric company. By way of an example, the power source for the wireless light bulb may be shared by the AC input and embedded rechargeable batteries all of the time. The rechargeable batteries may be charging all of the time or only during off peak times. Thus, during peak times, by having the AC input and rechargeable batteries share the load, the average power drawn from the AC input will be significantly lower during peak times if the AC input supplied all of the power. In alternate embodiments, the embedded batteries may always be the power source and the AC input power is used to charge the battery. Thus, the power required from the AC input will only be as much as is required to charge the battery and at its peak will only be as much as the battery charging cycle requires. The functionality to manage power and distribute the load during peak times may be programmed into an intelligent wireless light bulb and not require an external command to enter the load shedding mode. The intelligence may also be embedded in the wireless light bulb to receive commands to perform further load shedding functions if needed. For example, the percentage load from the AC input and from the embedded battery may be programmable based on time of day if there is a particular knowledge of when the peak demand times are, the light intensity level may be programmable to further reduce power consumption, a sensor

such as a motion sensor may be enabled to switchover to occupancy sensing to reduce power consumption etc.

[0257] In alternate embodiments, the AC powered battery embedded wireless light bulb contains rechargeable batteries and can return power to the grid. The rechargeable battery is charged when AC is on or can be programmed to charge at specific times or under specific conditions. The bulb can return power to grid when the bulb is off or when power can be returned because power stored exceeds power usage by some level. The result, as more bulbs are installed, is a distributed power network that allows power to be "stored" in every home, office building, retail space etc. that the bulbs are installed in and the stored energy can be returned to the grid when needed by the electric company. Backup storage capabilities that can be used to feed the grid during peaks in energy demand can offload the burden of power generation on the grid and can provide revenue or savings on the energy bill to end users. It is to be appreciated that any form of wireless power can be present in the bulb to harvest energy from the environment and charge the embedded batteries to form an energy generation source to send power from the environment to the grid. In some embodiments, the electric company may perform load shedding or load leveling by commanding an end user to use some local stored energy or the electric company may make use of the returned stored power to meet peak demand requirements. This may be done independently as determined by intelligence in the wireless light bulb, may be commanded by the user or may be commanded by the electric company (for example through a load control signal or a new type of signal that triggers the return of stored power to the grid).

[0258] In another embodiment, battery backup is built into AC powered recessed fixtures or down light assemblies for residential or industrial lighting. The battery backup can be switched over to if there is a dropout of AC power or some other characteristic is detected that makes AC power no longer desirable to use (brownout conditions, electrical surges, overvoltage conditions, voltage sag or flickers, line noise, frequency variations, switching transients, harmonic distortion, etc.) to the fixture for emergency or safety applications or for energy efficiency purposes. In addition, a sensor or RF control may be built into the fixture or down light assembly such that they can be wireless controlled or programmed. For example, an RF receiver can be built into the fixture or down light assembly. In alternate embodiments, the fixtures or down light assemblies may contain and use as a power source any combination of AC power and/or wireless power sources mentioned herein.

[0259] In another illustrative embodiment, a version of the wireless light bulb may provide for AC powered battery embedded LED recessed fixture 2100 applications. With reference to FIG. 21, illustrated is a perspective view of an embodiment of an AC powered battery embedded LED recessed fixture 2100. In the illustrated embodiment, the AC powered battery embedded LED recessed fixture 2100 includes a housing 2110, an AC input 2120, a printed circuit for AC/DC conversion and battery management functions 2130, a battery holder 2140, a printed circuit for a motion sensor circuit and LED drive circuitry 2150, a plurality of LEDs 2160 and a motion sensor 2170. In an alternate embodiment, the AC input is not used and the unit is solely powered by the embedded batteries thus elements 2120 and 2130 are not present or are not used.

[0260] By way of an example, an LED based 2×2, 2×4, and the like fluorescent replacement wireless light bulb may be designed with rechargeable or non-rechargeable batteries embedded and a circuit that makes the LED replacement bulb look like a fluorescent bulb to the ballast controller or otherwise allows the LED replacement bulb to operate with the ballast in place. An LED based 2×2, 2×4 and the like fluorescent replacement wireless light bulb with batteries embedded then may allow for the replacement of a fluorescent bulb with an LED battery backed bulb. This may allow a retrofit for battery backup for the consumer such that rather than incur the expense of the battery backed ballast controller (or battery backup elsewhere) and an electrician to do the electrical work to wire it in, the retrofit with battery backup can be done by the replacement of the fluorescent bulb. In alternate embodiments, the LED based 2×2, 2×4, and the like fluorescent replacement bulb may contain and use as a power source any combination of AC power and/or wireless power sources mentioned herein. In alternate embodiments, the LED based 2×2, 2×4, and the like fluorescent replacement bulb may contain and use any wireless control method mentioned herein.

[0261] Alternate embodiments of the wireless light bulb may be designed with a different housing that allows installation in a suspended grid ceiling system in locations typically occupied by 1×1, 2×2, 2×4 size ceiling tiles or the like. In this embodiment, the housing may contain any of the features of the wireless light bulb, but is designed in a ceiling tile form factor. In alternate embodiments, the housing may be designed in any form factor to be used in place of a fluorescent fixture such as but not limited to high bay fixtures, layin fixtures, strip fixtures, under cabinet fixtures, wall mount fixtures, wrap around fixtures, and the like. In these embodiments, the wireless light bulb may be designed to fit into place in the socket of the fixture (e.g. as a compact fluorescent lamp, fluorescent lamp or fluorescent bulb replacement) or the entire wireless light bulb fixture may be the same form factor as the fluorescent fixtures listed and be applicable for use in similar applications. The wireless light bulb may contain non-rechargeable or rechargeable batteries. In alternate embodiments, the wireless light bulb may have any type of connector on it that allows for charging by connection to a mating connector and that provides an AC or DC power source. In some embodiments the wireless light bulb may allow a connection to an AC input and may contain the required circuitry to convert AC to DC for the light source and wireless control. In some embodiments, the wireless light bulb may replace a fluorescent lamp or fixture that is connected to a resistive, reactive, or electronic ballast in which case the wireless light bulb may also contain circuitry to take the output of the ballast and convert it to DC power suitable for the light source and wireless control. By way of an example, a version of the wireless light bulb containing an RF receiver and a motion sensor may be designed into a housing that fits into a 2×2 ceiling grid. The wireless light bulb may also contain rechargeable batteries, an AC to DC converter and ballast conditioning circuit to connect to a ballast in the case where the wireless light bulb is a retrofit of a fluorescent fixture, and the like. It is to be appreciated that the ballast conditioning circuit may operate the wireless light bulb whether the wireless light bulb is connected to a ballast or not. There may also be intelligence (microcontroller, microprocessor, integrated circuit etc.) inside the wireless light bulb such that it can be programmed to draw power from the AC

input, from the rechargeable batteries or both. The intelligence may use a real time clock and be programmed to use the AC input and charge the batteries during off peak billing times and use battery power during on peak billing times such that there is an overall cost savings in energy usage. The unit may be programmed for operation based on a Time of Use (TOU) price plan from the energy company. The rechargeable battery capacity may or may not be enough to power the light source for the entire duration of the on peak billing time. In such a case, the intelligence may be able to switch between or control a sharing of the load between battery power and AC input power based on a measurement of battery capacity level, power use from the embedded batteries and from the AC input or any other measurable parameter that allows for an optimization for cost or minimizes power consumption of the combined use of embedded batteries and AC input power.

[0262] Alternate embodiments of the wireless light bulb may be designed with a housing that allows installation in a 2 or 4 pin plug-in fluorescent socket. In this embodiment, the housing may contain any of the features of a wireless light bulb and is designed with a 2 or 4 pin plug that allows it to be installed in a plug in fluorescent light fixture. By way of an example, the 2 or 4 pin wireless light bulb retrofit may be powered by the AC input but contain an LED light source, wireless control and/or wireless power functionality as mentioned herein for any wireless light bulb product such as a UPS light bulb, a motion wireless light bulb, a RF controlled wireless light bulb with a transceiver and the capability to form a mesh network, a programmable wireless light bulb etc. The wireless light bulb may physically couple with the fixture to support the wireless light bulb, yet electrical current may or may not flow between the fixture and the wireless light bulb. In such a case where electrical current does not flow between the fixture and the wireless light bulb, the wireless light bulb may contain one or more wireless power sources that provides power to the bulb. The wireless light bulb may contain one or more wireless control sources. In some embodiments, the wireless light bulb may replace a fluorescent light that is connected to a resistive, reactive or electronic ballast in which case the wireless light bulb may also contain circuitry to take the output of the ballast and convert it to DC power suitable for the light source and wireless control. The wireless light bulb may also contain non-rechargeable or rechargeable batteries. In the case where the bulb contains rechargeable batteries it may contain the circuitry to charge the batteries. There may also be intelligence (microcontroller, microprocessor, integrated circuit etc.) inside the wireless light bulb such that it can be programmed to draw power from the AC input, from the rechargeable batteries or both. The intelligence may use a real time clock and be programmed to use the AC input and charge the batteries during off peak billing times and use the battery power during on peak billing times such that there is an overall cost savings in energy usage. The wireless light bulb may be programmed for operation based on a Time of Use (TOU) price plan from the energy company. The rechargeable battery capacity may or may not be enough to power the light source for the entire duration of the on peak billing time. In such a case, the intelligence may be able to switch between battery power and AC input power based on a measurement of battery capacity level, power use from the embedded batteries and from the AC input or any other measurable parameter that allows for an optimization for cost or power consumption of the combined use of embedded batteries and AC input power.

[0263] In an alternate embodiment, an adapter may be designed that plugs into the 2 or 4 pin connector and has an Edison socket that a wireless light bulb may plug in to. It is to be appreciated that any power conditioning circuitry required to convert the AC input from the 2 or 4 pin connector to the appropriate input for the wireless light bulb will reside in the socket. In some embodiments, bulbs other than a wireless light bulb, for example any off the shelf incandescent, LED or CFL bulb, may plug into the 2 or 4 pin adapter. In such cases, the adapter may contain any form of wireless control, wireless power, intelligence or networking capability to provide wireless light bulb functionality to the installed off the shelf bulb.

[0264] Alternate embodiments of the wireless light bulb may be installed into a housing that allows installation in a fluorescent troffer, high bay fixtures, layin fixtures, strip fixtures, under cabinet fixtures, wall mount fixtures, wrap around fixtures, and the like. In this embodiment, the housing may contain one or more sockets such that wireless light bulbs in any standard size bulb (e.g. PAR30, PAR38, A19, R30, MR16 etc) or non-standard size bulb form factor may plug in. By way of an example, the housing may contain multiple Edison sockets such that PAR30 bulbs may be screwed in. Thus, with a housing that supports wireless light bulbs that screw or plug in, any type of wireless light bulb may be installed in the fixture. The housing may also have a connection to an AC input, wiring from the input to the sockets and any external circuitry to condition the AC input for use by the wireless light bulbs. In an alternate embodiment, a fluorescent retrofit LED bulb may be designed to be a retrofit in fluorescent tube applications where it is not designed in traditional fluorescent tube housing. A flat housing may be designed that contains LEDs and electronics down the length of the housing with pins allowing it to be installed in a socket for fluorescent tubes. In some embodiments, the shape of the flat housing and orientation of the LEDs may be such that two of the flat housings may be installed in a dual troffer such that they are geometrically opposed. In such a case, when both fluorescent LED retrofit bulbs are installed, there is an even pattern of LEDs installed in the troffer. By way of an example, two L-shaped fluorescent retrofit LED bulbs are designed such that the bottom part of the L contains an array of LEDs. When the two L-shaped fluorescent retrofit LED bulbs are installed, the two arrays of LEDs fill the entire space to provide the appearance of evenly spaced LEDs in the housing. It is to be appreciated that any shape of LED bulb and number of LED bulbs may be designed to fit into the space of a fluorescent troffer. In an alternate embodiment, a multiple fluorescent tube retrofit LED bulb may be designed such that the distance between the multiple tubes may be adjusted. Thus a single multiple fluorescent tube retrofit LED bulb may be designed such that it may be used in multiple troffers. It is to be appreciated that the multiple fluorescent tube retrofit LED bulb may be designed such that the width, length or both may be adjusted to fit into the troffer and plug into the socket. By way of an example, a dual fluorescent tube retrofit LED bulb is designed that is adjustable such that it may be installed in a number of common troffers that may be installed in fluorescent lighting applications.

[0265] In an alternate embodiment, the recessed fixtures or down light assemblies are completely battery powered. In addition, a sensor or RF control may be built into the fixture or down light assembly to control the unit. Wireless power and wireless control built into wireless lighting module fix-

tures or down lights allows them to be installed anywhere without the need for wires. In alternate embodiments, the fixtures or down light assemblies may contain and use as a power source any combination of wireless power sources mentioned herein.

[0266] In embodiments, a wireless light bulb may provide functionality equivalent to a “Three Way” light bulb by making use of the external communication interface and multiple light levels managed inside the bulb. Any number of light levels may be implemented in the wireless light bulb. An RF remote or other control method sends commands to change light levels in the wireless light bulb. By way of an example, an AC powered wireless light bulb is designed with an RF receiver inside. An RF remote with a single push button allows control of the light levels. From off, the first time the button is pushed, the light output goes to a low brightness level. The second time the button is pressed, the light output goes to a medium brightness level. The third time the button is pressed, the light output goes to a high brightness level. The fourth time the button is pressed, the light turns off. Any number of light levels, any brightness levels or sequence of brightness levels or method of control is possible. In an alternate embodiment, the number of light levels, brightness levels and sequence of brightness levels may be programmable by the user based on user preference. In alternate embodiments, the “Three Way” light bulb may respond to a switch on a lamp such that there are four levels—off and three light intensity levels. When the switch is turned once, the light intensity level goes from its first light intensity state to its next. By way of an example, the “Three Way” light bulb starts in the off position. When the switch is turned to the next position, the bulb detects the switch transition and changes the light intensity level from off to on at the lowest intensity level. When the switch is turned again to the next position, the bulb detects the switch transition and changes the light from the lowest intensity level to the next higher intensity level and so on. It is to be appreciated that the number of light levels, brightness levels and sequence of brightness levels that the “Three Way” light bulb may have in any of its embodiments may be factory set or programmable by the user based on user preference.

[0267] A plurality of use cases are possible in the use of AC power, wireless power sources and any combination thereof. In one use case, an AC powered battery embedded wireless light bulb contains an RF energy harvesting circuit. In this case, there may be a broadband antenna and circuitry to collect RF energy and charge the embedded batteries. In an alternate use case, a PAR30 type battery embedded wireless light bulb may contain a wireless power transmission receiver circuit and rechargeable batteries. The wireless power transmission circuit may allow the batteries to be charged off line, then have the wireless light bulb returned to the light socket for use.

[0268] In another illustrative embodiment, a battery embedded wireless light bulb may contain solar cells on its surface and rechargeable batteries to power the wireless control and light source. With reference to FIG. 22, illustrated is a perspective view of an embodiment of a battery embedded solar recharged PAR30 wireless light bulb 2200. In the illustrated embodiment, the battery embedded solar recharged PAR30 wireless light bulb 2200 includes a housing 2210, one or more solar cells 2220, a printed circuit for interfacing to the solar cell or cells and battery management functions, motion and light sensor circuitry 2230, a battery holder 2240, a plurality of LEDs 2250 and a motion sensor 2260 and light

sensor. The size of the solar cells can be set to match the anticipated amount of LED on time per the number of expected motion sensor triggers per some period of time. Note that there is some power consumption from the circuitry on the PCB to charge the batteries, for the motion detector, for the LED drive circuit etc., so it is to be appreciated that the power consumption and on time the battery embedded solar recharged PAR30 wireless light bulb can sustain every evening is equal to the amount of recharge that can be done by the solar cells and rechargeable batteries. It is to be appreciated that any form of wireless control or wireless power mentioned herein can be used in conjunction with this embodiment. It is to be appreciated that any size and shape of the solar cells can be used and they be placed on the housing in any manner conceivable. It is also to be appreciated that any size or type of rechargeable battery can be used in conjunction with this embodiment. In an alternate embodiment, there is a method to replace the batteries designed in, thus if the amount of on time exceeds the recharge rate, the rechargeable batteries can be removed, recharged to full or close to full capacity and then returned to the wireless light bulb. In this use case, the motion sensor provides for a highly efficient use of the power consumption such that for a limited amount of recharging (e.g. small solar cells used on the bulb), an appropriate amount of light can be provided for short periods of time such that the average power consumption is low over time, but power consumption is high for brief periods of time only when the light is needed.

[0269] In references to battery embedded, AC powered battery embedded, or any combination of power source wireless light bulbs, it is to be appreciated the chargeable and rechargeable batteries can be replaced by any energy storage element mentioned herein. For example, a battery embedded wireless light bulb can be a fuel cell embedded wireless light bulb. An AC powered battery embedded wireless light bulb can use one or more super capacitors as a power source to power a glow mode in certain applications.

[0270] An external light socket adapter may be designed with batteries embedded to battery backup any kind of light bulb that plug into a socket. The external light socket adapter can be designed as an adapter for any type of socket to provide the described functionality for any of the plurality of bulb types mentioned herein. By way of an example, an adapter plugs into an Edison socket and also has an Edison socket that accepts an A19 type bulb. An incandescent, compact fluorescent, and LED type light bulb can plug into the socket adapter. The socket adapter may contain embedded rechargeable or non-rechargeable batteries, the circuitry to switch over to the embedded batteries, an AC/DC converter, a DC/AC inverter, a charging circuit to charge the embedded batteries, and the intelligence to implement a switchover between AC power and backup power. In embodiments, this function can match that of the UPS wireless light bulb but with the batteries external to the bulb such that any standard bulb could be used. It is to be appreciated that the same functionality provided by the UPS wireless light bulb mentioned herein may be implemented by the external light socket adapter and a standard bulb plugged in.

[0271] An AC outlet adapter or an AC outlet replacement may be designed with batteries embedded to provide power to any kind of electrical device that plugs into the outlet. By way of an example, an adapter may plug into an AC wall outlet and also have an AC socket that an electrical device that plugs into an AC outlet can plug into. In this example, the adapter that

plugs into an AC wall outlet may have more than one AC socket that electrical devices may plug into. In an alternate example a cable with an AC plug on one end and the adapter at the end of the cable may be designed similar to an electrical extension cord or power strip where the assembly adapter at the end may contain the embedded batteries. An AC powered device of any kind such as a lamp, television, television peripheral, computer, appliance, washer, clothes dryer, refrigerator, freezer, electric range, microwave oven, electric water heater, vacuum cleaner, cell phone charger, stereo, air conditioner, HVAC devices, electric or hybrid vehicles, electric motors, industrial and manufacturing machinery etc, may plug into the AC outlet adapter or an AC outlet replacement. In alternate embodiments, the AC powered device of any kind may be designed with the batteries embedded inside the device to provide power to the device. In alternate embodiments, an external light socket adapter may be designed with the batteries embedded inside the device to provide power to any light source or device connected to it. The AC powered device, socket adapter, outlet adapter or outlet replacement may contain embedded rechargeable or non-rechargeable batteries, the circuitry to switch over to the embedded batteries, an AC/DC converter, a DC/AC inverter, a charging circuit to charge the embedded batteries, and the intelligence to implement a switchover between AC power and battery power. In embodiments, power may be switched over to battery if there is a dropout of AC power or some other characteristic is detected that makes AC power no longer desirable to use (brownout conditions, electrical surges, overvoltage conditions, voltage sag or flickers, line noise, frequency variations, switching transients, harmonic distortion, etc.) to the outlet, socket or AC powered device. Power may be switched to AC power, battery power or both power sources may be used for emergency or safety applications, for energy efficiency, for energy cost savings or peak load reduction (load leveling) purposes. In addition, a sensor or RF control may be built into the AC powered device, socket adapter, outlet adapter or outlet replacement such that they can be wireless controlled, status can be gathered from it, commands may be sent to switch to a different power source, it may be remotely programmed, and the like. For example, an RF transceiver can be built into the AC powered device, socket adapter, outlet adapter or outlet replacement and a device such as a wall switch, remote control, RF transceiver that can plug into a computer and be controlled by a software program, etc. may communicate with the AC powered device, socket adapter, outlet adapter or outlet replacement. In alternate embodiments, the AC powered device, socket adapter, outlet adapter or outlet replacement may contain and use as a power source any combination of AC power and/or wireless power sources mentioned herein. In alternate embodiments, an AC circuit with battery embedded device performing the same function of the AC outlet adapter with embedded batteries may be installed to support multiple AC outlets or connected AC powered devices by inserting the device in-line at the point of entry for AC power for that electrical circuit. By way of an example, in a residence, the battery embedded device can be installed in-line after the circuit breaker that can provide battery power on multiple AC drops such that the embedded batteries inside the device may supply power to all of the devices that may be drawing AC power on the circuit in a manner as described for the AC powered device, external light socket adapter, AC outlet adapter or AC outlet replacement.

[0272] A wall switch or lighting control component of any kind may be designed with batteries embedded to allow battery power to be the power source for the lighting circuit or any AC powered device connected to the circuit controlled by the wall switch (for example a device plugged into an AC outlet controlled by the switch). The wall switch or lighting control component may be designed any size or shape for any type of wall switch or lighting control component to provide the described functionality for any of the plurality of bulb types mentioned herein. By way of an example, a wall switch with three switches may be used to control multiple light sockets or wall outlets in a residential or commercial application. In addition to the three switches, internally the housing of the wall switch may have embedded batteries. An incandescent, compact fluorescent, LED type light bulb or AC powered device of any kind may derive power from the AC input, embedded batteries or both. It is to be appreciated that any size or shape wall switch or lighting control component may have any size or shape embedded batteries. The wall switch or lighting control component may contain embedded rechargeable or non-rechargeable batteries, the circuitry to switch over to the embedded batteries, an AC/DC converter, a DC/AC inverter, a charging circuit to charge the embedded batteries, and the intelligence to implement a switchover between AC power and battery power. In embodiments, this function may match that of the UPS wireless light bulb but with the batteries external to the bulb such that any standard bulb could be used. It is to be appreciated that the same functionality provided by the UPS wireless light bulb mentioned herein may be implemented by the wall switch or lighting control component and any type of bulb plugged in or AC powered device connected. In addition, monitoring the sense of the wall switch (open or closed) and the ability to monitor whether AC power is present and acceptable before the switch allows intelligence in the switch to select the power source. For example, if the switch is closed and AC power is not present, the wall switch may be able to switchover to battery power because it may assume there is a power outage. In addition, intelligence in the wall switch may need to detect changes in the state of switch or the AC power input to switch back over to AC power when it is present and acceptable again and may need electrical circuitry, a relay, an optoisolator etc. to allow the sharing of the load by power sources or the switching from one power source to another power source. In alternate embodiments, additional intelligence, wireless controls and wireless power sources may be embedded in the wall switch or lighting control component to implement any of the functionality mentioned herein.

[0273] In embodiments, an external light socket adapter, AC outlet adapter, an AC outlet replacement, an AC powered device, an AC circuit with embedded battery device designed with batteries embedded, wall switch or lighting control component and the like, may include intelligence (microcontroller, microprocessor, integrated circuit etc.) designed in such that it may be programmed to draw power from the AC input, from the rechargeable batteries, or both. In alternate embodiments, an external light socket adapter, AC outlet adapter, AC outlet replacement, AC powered device, AC circuit with embedded battery device, wall switch or lighting control component and the like, may contain and use as a power source any combination of AC power and/or wireless power sources (batteries, fuel cells, super capacitors, solar cells, RF energy harvesting circuit etc.) mentioned herein and the included intelligence may be used to make decisions when

and how to use the power sources. The intelligence may use a real time clock and be programmed to use the AC input and charge the batteries during off peak billing times and use battery power during on peak billing times such that there is an overall cost savings in energy usage. The intelligence may use a real time clock and be programmed in any way to implement load leveling such as to use the AC input and charge the batteries during off peak times and use battery power during on peak times such that there is a reduction in energy usage during peak times. Thus, the external light socket adapter, AC outlet adapter, AC outlet replacement, AC powered device, AC circuit with embedded battery device, wall switch or lighting control component and the like have the ability of "moving power in time" by storing power at some time and using the power at another time. By way of example, the device may be programmed for operation based on a Time of Use (TOU) price plan from the energy company. The rechargeable battery capacity may or may not be enough to power the device plugged in for the entire duration of the on peak billing time. In such a case, the intelligence may be able to switch between or control a sharing of the load between battery power and AC input power based on a measurement of battery capacity level, power use from the embedded batteries and from the AC input or any other measurable parameter that allows for an optimization for cost or minimize power consumption of the combined use of embedded batteries and AC input power. The control and gathering of status from an external light socket adapter, an AC outlet adapter, an AC outlet replacement, an AC powered device, an AC circuit with embedded battery device, wall switch or lighting control component and the like, may be done by an intelligent electrical meter, smart meter, control software and the like. In such a case the meter or control software may directly communicate with one or more of the adapters or devices over an appropriate communication interface using a protocol that allows the adapters or devices and smart meter or control software to exchange information. By way of an example, the adapters or devices may measure the amount of power consumed over a period of time and an intelligent electrical meter, smart meter, a remote device, control software and the like, through an intelligent electrical meter, smart meter, and the like (for example via the smart grid), may retrieve that information to provide that information for any purpose. In another example, an intelligent electrical meter, smart meter, a remote device, control software and the like, through an intelligent electrical meter, smart meter, and the like, may control the adapters or devices to turn them on, off, set the light intensity level, control which power source or sources are used (battery, AC and/or a wireless power source), retrieve any information from adapters or devices or control any sensor or intelligence present in adapters or devices. In addition to controlling a switchover to battery power, other applications are possible. Information or a record of usage from each power source may be stored and retrieved. The stored data may pertain to power usage, however it may also pertain to sensor gathered information. For example, an external light socket adapter, an AC outlet adapter, an AC outlet replacement, an AC powered device, an AC circuit with embedded battery device, wall switch or lighting control component and the like may contain an occupancy sensor, like a motion sensor, that can record times and levels of occupancy in an area that can later be retrieved.

[0274] In embodiments of an external light socket adapter, AC outlet adapter, an AC outlet replacement, an AC powered

device, an AC circuit with embedded battery device designed with batteries embedded, wall switch or lighting control component and the like, the electric company may implement load shedding or load leveling using these components throughout its power distribution network by remotely off-loading power usage at times when power demand is high by commanding some portion or the entire distributed network of components to switchover to battery power. In some embodiments, the external light socket adapter, AC outlet adapter, an AC outlet replacement, an AC powered device, an AC circuit with embedded battery device designed with batteries embedded, wall switch or lighting control component and the like may receive a load control signal from the electric company or end user to implement load shedding. The control may force a reduction in power consumption from the AC input by either reducing power usage (by turning AC powered devices such as appliances off for example) or by switching some portion of or all of the power source to battery power. In some embodiments, external light socket adapter, AC outlet adapter, an AC outlet replacement, an AC powered device, an AC circuit with embedded battery device designed with batteries embedded, wall switch or lighting control component and the like, may respond to supply conditions (demand response) during peak or critical times or based on market prices by adjusting usage or by switching some portion or all of the power source to battery power. In some embodiments, load shedding or demand response may happen without an explicit command from the electric company. By way of an example, a clothes dryer may be plugged into an AC outlet adapter with the capabilities mentioned herein. In response to a load shedding command, the AC outlet adapter may turn off power to the clothes dryer or alternatively transfer some or all of the load to the battery power source. In an alternate example, when run during peak billing times, the AC outlet adapter the clothes dryer is plugged into may draw some or all of the load from the battery power source to reduce the cost of usage of the clothes dryer. In some embodiments, the electric company may perform load shedding by commanding an end user to use some local stored energy or the electric company may make use of the returned stored power to meet peak demand requirements. This may be done independently as determined by intelligence in the external light socket adapter, AC outlet adapter, an AC outlet replacement, AC powered device, an AC circuit with embedded battery device designed with batteries embedded, wall switch or lighting control component and the like, may be commanded by the user or may be commanded by the electric company (for example through a load control signal or a new type of signal that triggers the return of stored power to the grid). In embodiments of an external light socket adapter, AC outlet adapter, an AC outlet replacement, an AC powered device, an AC circuit with embedded battery device designed with batteries embedded, wall switch or lighting control component and the like that may use an AC power input and embedded battery power with an intelligent, programmable controller may also contain grid tie inverter circuitry to allow the stored battery power to be converted to AC. The grid tie inverter circuitry may allow the external light socket adapter, AC outlet adapter, an AC outlet replacement, an AC powered device, an AC circuit with embedded battery device designed with batteries embedded, wall switch or lighting control component and the like to be directly connected to the grid and to supply power back to the grid. The grid tie inverter may allow stored battery power to be used locally or to be sold back to the utility in the

case that there is surplus power. The control of the return of energy to the grid may be based on battery capacity level, time of day, the (TOU) billing plan from the energy company, commands received over the communication interface to return or stop returning energy to the grid either from local intelligence (intelligent electrical meter, smart meter, and the like) or from the energy company, known or learned energy consumption patterns where the additional energy may be needed or any other reason that it may be desired to return energy to the grid.

[0275] In embodiments of an external light socket adapter, AC outlet adapter, an AC outlet replacement, an AC powered device, an AC circuit with embedded battery device designed with batteries embedded, wall switch or lighting control component and the like, a function similar to the UPS light bulb may exist such that there is circuitry inside the device that may detect that AC power is no longer present (power failure) or some other characteristic that makes AC power no longer desirable to use (brownout conditions, electrical surges, over-voltage conditions, voltage sag or flickers, line noise, frequency variations, switching transients, harmonic distortion etc.) at the device power input. In this case the device may switch over to battery power automatically to power the control circuitry and to continue providing power to the device. This application, the uninterruptable power supply external light socket adapter, AC outlet adapter, an AC outlet replacement, an AC powered device, an AC circuit with embedded battery device designed with batteries embedded, wall switch or lighting control component and the like, provides power during a power outage using the embedded battery power source. Additional intelligence may be designed into the device to provide features or extend the amount of time usable power may be available when powered by the embedded battery power source. The device may also measure the impedance, resistance, and/or capacitance across the AC power input and return or may measure any other electrical characteristic of the AC power input and return to determine whether the controlling switch or breaker is open or closed (or if electricity has been turned off at any point up to the AC input of the device). By way of an example, if the controlling switch or breaker is open, there may be a high impedance detected across the input AC power and return. If the controlling switch or breaker is closed, there may be a measureable impedance, resistance and/or capacitance or electrical characteristic different from when the controlling switch or breaker is open. A threshold may be set in the device such that if the measurement is above or below the threshold, the switch or breaker is closed, and if the measurement is on the opposite side of the threshold, the switch or breaker is open. The device may be controlled by the state of the controlling switch or breaker (on or off), but may also detect the condition when the controlling switch or breaker is closed but AC input power is not present or is not acceptable and may be able to switch over to the rechargeable or non-rechargeable batteries that are embedded as the power source. In some embodiments, the UPS light bulb may perform an impedance discontinuity check to determine if the controlling switch or breaker is open or closed. In some embodiments, the device may generate a signal onto the line and monitor the electrical response of the line to determine if the response indicates an open circuit that may be indicative of a switch or breaker open in the lighting circuit. By way of an example, the device may perform a function typical of a time domain reflectometer by generating a short rise time pulse at the connection to input and monitor

the input for a reflected signal that would be indicative of an open circuit. If the reflected signal exceeds a set threshold, it may indicate an open circuit. In some embodiments, the device may need to learn where such a threshold should be set. The device may be installed in many variations of power distributions circuits where the amount or type of wiring to the switch or breaker may vary and where there may be many other sources of loads on the circuit (such as other devices, multiple switches or controls etc.) therefore it may have to adjust its detection circuitry to operate properly. It is to be appreciated that the setting of the threshold may be done automatically by the device or manually by a user through any process that may allow the device to be set to a threshold where one side of the threshold indicates the switch or breaker is open and the other side of the threshold indicates the switch or breaker is closed. It is to be appreciated that when the switch sense functionality is implemented, the switch or breaker may still be able to turn on and off power to the device even when running off of the embedded battery power source because the device may be able to determine if the switch is on or off and apply power or not apply power to the device based on the switch position. In such a case, the switch sense circuitry may still need to be powered along with any other necessary circuitry to implement this function even when the device is not being powered.

[0276] In an illustrative embodiment shown in FIG. 23, the block diagram shows an example AC powered battery embedded wireless light bulb system 2300 that may use an AC power input and embedded battery power with an intelligent, programmable controller to provide cost savings, security and convenience benefits to a lighting installation. In the illustrated embodiment, the AC powered battery embedded wireless light bulb system 2300 may include an AC/DC converter 2310, a charging circuit with rechargeable batteries 2320, power selection and conditioning circuitry 2330, an intelligent, programmable time of use and power source/charging controller 2340, a light source or load 2350 and a communication interface 2360, and the like. The AC input may be connected to the AC powered battery embedded wireless light bulb system 2300 by a light socket, wall outlet, terminal block, connector, hardwired connection or any common connection that a device requiring AC power may have to an AC power input. The AC input block may contain a transformer, line cap, fuse, inrush limiter or other type of power circuitry commonly found at the input of an AC/DC converter or an AC powered device. The output of the AC/DC converter 2310 may be a regulated DC source such as a DC/DC converter circuit. It may be a constant current source to the load for example to provide constant current to a chain of LEDs in series. In some embodiments there may be multiple circuits at the output of the AC/DC converter such that one circuit may provide a power source for low current draw circuitry such as the an intelligent, programmable time of use and power source/charging controller 2340 and communication interface 2360 and a second circuit may provide a power source for high current draw circuitry such as the light source or load 2350. It is to be appreciated that any number power sources may be created at the output of the AC/DC converter to meet the needs of the application.

[0277] The output of the AC/DC converter may be connected to a charging circuit with rechargeable batteries 2320. In one embodiment, the charging circuit includes an integrated circuit, such as a Microchip MCP73838 battery charge management controller with some external components to

monitor and charge one or more Li-Ion rechargeable batteries embedded in the AC powered battery embedded wireless light bulb system 2300. It is to be appreciated that any charging circuit or type of rechargeable battery may be used in the AC powered battery embedded wireless light bulb system 2300. The intelligent, programmable time of use and power source/charging controller 2340 may be a microcontroller, microprocessor, integrated circuit, electrical circuit or the like. In the embodiment using a MCP73838 and Li-Ion batteries, a microcontroller such as the FREESCALE SEMICONDUCTOR MC68HC908QT microcontroller may be used to monitor the charge status of the Li-Ion batteries, control the charge current to the Li-Ion batteries, put the charging circuit in standby mode, detect when charging is complete, detect a battery temperature fault, start a timer to time the duration of charging or any other status or control function relevant to charging circuitry or rechargeable batteries.

[0278] Power selection and conditioning circuitry 2330 may be used to select the power source for the internal circuitry and light source or load 2350. The power selector and conditioning circuitry 2330 may be configured to select AC power as the power source, the embedded batteries as the power source with the selection controlled by the intelligent, programmable time of use and power source/charging controller 2340, and the like. In one embodiment, the selection may be done with a pair of MOSFETs that can be controlled by the controller such that either the AC source is selected or the embedded battery power source is selected. With the addition of diodes, the AC source and embedded battery power source may share the load of the light source or load 2350. In an alternate embodiment, the selection of power source may be done automatically with a single MOSFET and a Schottky diode such that if the AC source is present, the power source will automatically be the AC source however if the AC source is not present, the power source will automatically switch to the embedded battery power source. The Schottky diode provides protection to prevent reverse current from flowing to the AC power source. When the AC power source is present the embedded battery may or may not be in a charging mode. In another alternate embodiment, there is an additional wireless power source on the AC powered battery embedded wireless light bulb system 2300 that may provide a power source or battery charging source (energy harvesting methods such as solar cells, wireless power transfer, capturing radio frequency energy etc.). In this case, the power selection and conditioning circuitry 2330 would be expanded to allow for selection and use of all of the power sources. It is to be appreciated that any number of wireless power sources may be used in conjunction with the claimed subject matter.

[0279] In one embodiment, the light source or load 2350 may be one or more LEDs. The power selection and conditioning circuitry 2330 may also include any driving circuit required to power the light source or load 2350. In the embodiment where LEDs are used as the light source and the one or more LEDs are arranged in series, the AC power source or embedded battery power source may require an LED driver circuit at the output of the power selection and conditioning circuitry 2330 to generate a constant current source or to generate the required DC voltage to turn on all of the LEDs in the series. In an alternate embodiment, the output of the AC/DC converter may have the proper characteristics to drive the LEDs, however the embedded battery power source may require an LED driver circuit to generate a constant current

source and/or to step of the DC voltage to the required DC voltage to turn on all of the LEDs in the series. In alternate embodiments, the light source may be a compact fluorescent lamp or fluorescent lamp and the block diagram shown constitutes an electronic ballast integrated into the lamp. In this case, there may also be an inverter circuit (DC/AC circuit) in the power selection and conditioning circuitry **2330** to create the proper starting and operating electrical condition for the fluorescent light source. In alternate embodiments the load may be an external light socket adapter or a device connected to an AC outlet adapter or an AC outlet replacement. In any of these embodiments, there may be a DC/AC inverter circuit to create the proper AC output power for the attached device. In some embodiments, the AC/DC converter may only be used to charge the batteries and power local circuitry. The AC power source may be switched to the load via a relay, solid stated device, or other switching device or the embedded battery power source may be selected by the intelligent, programmable time of use and power source/charging controller **2340** to supply power to the load. In the case where the embedded battery power source is a chosen power source, the DC/AC inverter would take the embedded battery DC output and convert to AC power to create the proper AC output power for the attached device. In some embodiments, there may be a very large, super or ultra capacitor in or before the power selection and conditioning circuitry **2330** for energy storage in addition to the rechargeable batteries. This may take advantage of some characteristics of capacitors to offset limitations in rechargeable batteries such as the fast charging time of capacitors.

[0280] In the illustrated embodiment, an intelligent, programmable time of use and power source/charging controller **2340**, a light source or load **2350** and a communication interface **2360** may be used to control the operation of the AC powered battery embedded wireless light bulb system **2300**. In the embodiment containing a MC68HC908QT microcontroller and an LED light source, the microcontroller may be used to control the light source based on firmware programmed into flash memory on the microcontroller. The microcontroller may control the light source to turn it on or off, control the intensity of one or more LEDs via pulse-width modulation or other methods to control the current through the light source to provide power savings, provide dimming functionality, multiple light levels, a glow function, and so on, control which power source or sources are used (battery, AC and/or a wireless power source), control state changes based on time of day, set specific on times, off times and brightness levels based on billing rates from the power company at different times of the day (for example based on time of use, TOU billing plans), automatic shut-off times or timers, automatic turn on times or timers, change color or may be programmed in substantially any manner to control the light source. The microcontroller may also control the selection of the power source or sources based on a program that can set state and change state based on the inputs to the microcontroller. The microcontroller may also be used to gather status on any of the power sources, the light source or the usage there of. For example, with additional circuitry necessary to gather the information, the microcontroller may record power usage, temperature of the components in the system, battery capacity level, light output, light color etc.

[0281] A communication interface **2360** may be used by an external computer-related entity, either hardware, software (e.g., in execution), and/or firmware to communicate with the

intelligent, programmable time of use and power source/charging controller **2340**. The external entity may use the communication interface such that the intelligence in the AC powered battery embedded wireless light bulb system **2300** in the lighting installation may be programmed, controlled and information or status can be retrieved for energy control and conservation, emergency functions, for safety and security, for convenience and any other functionality desired by a user. It is to be appreciated that the AC powered battery embedded wireless light bulb system **2300** may contain processing resources and computer program such that it can implement a wide range of functionality or the AC powered battery embedded wireless light bulb system **2300** may contain only a few functions and the processing resources and computer program reside in the external entity. In this way the intelligence may either be distributed in the AC powered battery embedded wireless light bulbs that are installed or be centralized in the external computer-related entity.

[0282] It is to be appreciated that the AC powered battery embedded wireless light bulb system **2300** may be designed in any size or shape housing to meet the requirements of any standard size bulb (e.g. PAR30, PAR38, A19, R30, MR16 etc), non-standard size bulb, fixture, compact fluorescent bulb, fluorescent bulb or lamp (e.g. T4, T5, T8, circular etc.) or down light assembly (e.g. recessed fixtures, fluorescent fixtures or down light fixtures for residential, commercial or industrial lighting), or the like. It is also to be appreciated that the AC powered battery embedded wireless light bulb system **2300** may be designed in any size or shape housing to meet the requirements of any external light socket adapter, AC outlet adapter, an AC outlet replacement or an AC circuit with embedded battery device designed with batteries embedded application.

[0283] In an illustrative embodiment shown in FIG. **24**, the block diagram shows an example AC powered battery embedded wireless light bulb system that may use an AC power input and embedded battery power with an intelligent, programmable controller but also contains grid tie inverter circuitry to allow the stored battery power to be converted to AC. The grid tie inverter circuitry may allow the AC powered battery embedded wireless light bulb system to be directly connected to the grid and to supply power back to the grid. The grid tie inverter may allow stored battery power to be used locally or to be sold back to the utility in the case that there is surplus power. In the illustrated embodiment, the grid tied AC powered battery embedded wireless light bulb system **2400** may include an AC/DC converter **2410**, a charging circuit with rechargeable batteries **2420**, power selection and conditioning circuitry **2430**, an intelligent, programmable time of use and power source/charging controller **2440**, a light source or load **2450**, a communication interface **2460**, a grid tie inverter **2470**, and the like. In alternate embodiments there may be one or more additional energy harvesting circuits **2480** (including energy harvesting methods such as solar cells, wireless power transfer, capturing radio frequency energy, etc.) that may provide power for the light source or load **2450**, charge the embedded batteries or may provide power to the grid tie inverter to return to the grid. The grid tied AC powered battery embedded wireless light bulb system **2400** may provide all of the functionality described for the AC powered battery embedded wireless light bulb system **2300**, but the intelligent, programmable time of use and power source/charging controller **2440** may also control the return of energy to the grid (for local use and/or to be sold back to the

utility). The control of the return of energy to the grid may be based on battery capacity level, time of day, the (TOU) billing plan from the energy company, commands received over the communication interface to return or stop returning energy to the grid either from local intelligence (intelligent electrical meter, smart meter, and the like) or from the energy company, known or learned energy consumption patterns where the additional energy may be needed or any other reason that it may be desired to return energy to the grid.

[0284] In an alternate embodiment, there may not be a grid tie inverter in the grid tied AC powered battery embedded wireless light bulb system 2400 but rather wires into the housing that allow for an electrical connection to the grid tied AC powered battery embedded wireless light bulb system 2400 such that multiple grid tied AC powered battery embedded wireless light bulb systems can be connected externally to an inverter to provide power for local use or to a grid tie inverter to provide power to the power grid. There may be a typical AC power input to the grid tied AC powered battery embedded wireless light bulb system 2400, but also two or more wires that can be chained or connected separately to an inverter, to a grid tie inverter or to a connection panel that can combine and condition the inputs to then connect to an inverter or grid tie inverter. In this way, one electrical circuit containing multiple grid tied AC powered battery embedded wireless light bulb systems or an entire lighting installation containing multiple grid tied AC powered battery embedded wireless light bulb systems can be fed back to one or more inverters or grid tie inverters to implement similar functionality as if the inverter or grid tie inverter was located in the grid tied AC powered battery embedded wireless light bulb system 2400. It is to be appreciated that the output onto the two or more wires may be AC or DC in nature. For example, the output may be 12VDC and ground, the output may be 48VDC and ground, the output may be 12VAC and ground etc. In the case where DC power is output, there may be no inverter and there may be a DC/DC converter to generate the required DC output voltage. It is also to be appreciated that the grid tied AC powered battery embedded wireless light bulb system 2400 may include circuitry to allow chaining of the wiring (diode-ored for example) or may connect to independent wiring back to an inverter, to a grid tie inverter or to a connection panel that can combine and condition the inputs to then connect to an inverter or grid tie inverter. In some embodiments, there may be an additional charge controller and external battery or batteries for additional energy storage outside of the grid tied AC powered battery embedded wireless light bulb systems.

[0285] In embodiments, the grid tie inverter may need to ensure that the power supplied by the grid tie inverter will be in phase with the grid power. To synchronize phase with grid power, there may be circuitry in the grid tied AC powered battery embedded wireless light bulb system 2400 to monitor the AC input power and lock to the phase with a phase locked loop, an AC power zero crossing detector circuit or the like. This may be used to set the phase of the output of the grid tie inverter to be in sync with the grid. In alternate embodiments, the phase of grid power may not be directly detected in the grid tied AC powered battery embedded wireless light bulb system 2400 but may be detected in an external device that can communicate the phase of the grid power to the grid tied AC powered battery embedded wireless light bulb system 2400 via the a communication interface 2460. A grid tie inverter may also ensure that the voltage of the grid tie inverter output is slightly higher than the grid voltage to

enabling current to flow out to the grid. The detection of the grid voltage may be done with circuitry inside the grid tied AC powered battery embedded wireless light bulb system 2400 or in some embodiments the grid voltage may be detected in an external device that can communicate the grid voltage to the grid tied AC powered battery embedded wireless light bulb system 2400 via the a communication interface 2460. By way of an example, a separate device connected to grid power (at an AC outlet, at the circuit breaker box etc.) may detect the phase of grid power and/or the grid voltage. It may also contain an RF transmitter that can transmit wirelessly to the grid tied AC powered battery embedded wireless light bulb system 2400 enough information to know the phase of the grid power (analog to digital representation of the waveform, times of zero crossing etc.) and/or the grid voltage such that embedded intelligence, such as a microcontroller, could control the grid tie inverter such that it is in sync with grid power and the output voltage is slightly higher than the grid voltage. There may be a mechanism to allow the grid tie inverter to be disconnected from the power grid. The disconnect from the grid may be automatically controlled allowing a disconnect from the grid if the grid voltage is turned off, if the phase of grid power cannot be synchronized with, if there is no information from an external source about the phase of grid power, etc, or it is not appropriate to supply power back to the grid via the grid tie inverter for any reason. It may also disconnect anytime the grid tied AC powered battery embedded wireless light bulb system 2400 may not be supplying power back to the grid. Embedded intelligence may be programmed based on battery capacity level, time of day, the (TOU) billing plan from the energy company, commands received over the communication interface to return or stop returning energy to the grid either from local intelligence (intelligent electrical meter, smart meter, and the like) or from the energy company, known or learned energy consumption patterns where the additional energy may be needed or any other reason that it may be desired to return energy to the grid. By way of an example, multiple grid tied AC powered battery embedded wireless light bulb systems on the same circuit or in the same residence, commercial or industrial building or geographical area may or may not return power to the grid at the same time. An intelligent device such as a computer running a software program, a remote control, a building management unit, a lighting circuit control unit etc. may implement a scheme to enable the grid tied AC powered battery embedded wireless light bulb systems such as time division multiplexing algorithm, an algorithm to control which grid tie inverter is on and which grid tie inverter is off to make sure there is no or limited contention, an algorithm to control which grid tie inverters are on based on a knowledge of the energy needs of the consumer or billing plan of the consumer, an algorithm based on the battery capacity level of the grid tied AC powered battery embedded wireless light bulb systems, etc.

[0286] It is to be appreciated that the grid tied AC powered battery embedded wireless light bulb system 2400 may be designed in any size or shape housing to meet the requirements of any standard size bulb (e.g. PAR30, PAR38, A19, R30, MR16, etc), non-standard size bulb, fixture, compact fluorescent bulb, fluorescent bulb or lamp (e.g. T4, T5, T8, circular etc.) or down light assembly (e.g. recessed fixtures, fluorescent fixtures or down light fixtures for residential, commercial or industrial lighting), or the like. It is also to be appreciated that the grid tied AC powered battery embedded wireless light bulb system 2400 may be designed in any size

or shape housing to meet the requirements of any external light socket adapter, AC outlet adapter, an AC outlet replacement or an AC circuit with embedded battery device designed with batteries embedded application.

[0287] In embodiments containing rechargeable batteries, a charge management controller and intelligence, the intelligence may be used to optimize rechargeable battery life by controlling recharge cycles in such a way to optimize the usable life of the batteries. By way of an example, a microcontroller built into a wireless light bulb may monitor the depth of discharge of the rechargeable battery. Based on the status of the battery depth of discharge, the microcontroller may start a recharge cycle early rather than allow the rechargeable batteries to be deeply discharged. The usable capacity of rechargeable batteries may depend on the rate of discharge and the allowable voltage at the end of discharge. An intelligent program running on a microcontroller may adjust the charge cycles to optimize the usable life of the rechargeable batteries. In the example of the AC powered battery embedded wireless light bulb, the end result is the ability to extend battery life such that with either an optimization of the recharge cycles or sizing battery capacity to lessen the depth of the discharge needed, the limiting factor of an AC powered battery embedded wireless light bulb when the light source is LEDs may be the life of the LEDs rather than the expected usable life of the rechargeable batteries.

[0288] In an illustrative embodiment shown in FIG. 25, the block diagram shows an example system that uses an electronic ballast and embedded battery power in a compact fluorescent lamp with an intelligent, programmable controller. In the illustrated embodiment, the AC powered battery embedded CFL wireless light bulb 2500 may include an electronic ballast 2510, a charging circuit with rechargeable batteries 2520, power selection and conditioning circuitry 2530, an intelligent, programmable time of use and power source/charging controller 2540, a fluorescent tube 2550, a communication interface 2560, and the like. The functionality is very similar to the AC powered battery embedded wireless light bulb system 2300, however in this case, a charging circuit with rechargeable batteries 2520 is connected prior to the DC/AC inverter in the electronic ballast. The power selection and conditioning circuitry 2530 may be used by the intelligent, programmable time of use and power source/charging controller 2540 to select the power source for the fluorescent tube 2550 or to supply no power to the fluorescent tube 2550 to turn it off. It is to be appreciated that the intelligent functions described AC powered battery embedded wireless light bulb system 2300 for the intelligent, programmable time of use and power source/charging controller 2540 and that may be done over the communication interface 2560 are applicable to the AC powered battery embedded CFL wireless light bulb 2500. In one embodiment, the AC powered battery embedded CFL wireless light bulb 2500 may be designed to operate similar to or the same as a UPS wireless light bulb. In an alternate embodiment, the CFL wireless light bulb is only AC powered and has no embedded power source. In such a case, the AC powered CFL wireless light bulb may contain wireless control and/or wireless power as well as be able to implement any of the intelligent functionality as mentioned herein for any wireless light bulb product such as a motion wireless light bulb, a RF controlled wireless light bulb with a transceiver and the capability to form a mesh network, a programmable wireless light bulb etc. In an alternate embodiment, the AC powered battery embedded CFL wireless light

bulb 2500 may not have an AC input and runs off of power supplied by an embedded rechargeable or non-rechargeable battery and with a DC/AC inverter to convert to AC power to create the proper AC output power for the fluorescent tube. In an alternate embodiment, the AC powered battery embedded CFL wireless light bulb 2500 may contain a grid tie inverter. In such a case where the AC powered battery embedded CFL wireless light bulb 2500 contains a grid tie inverter, it is to be appreciated that the intelligent functions described grid tied AC powered battery embedded wireless light bulb system 2400 for the intelligent, programmable time of use and power source/charging controller 2540 and that may be done over the communication interface 2560 along with the functionality gained by having the grid tie inverter in the bulb are applicable to the AC powered battery embedded CFL wireless light bulb 2500.

[0289] It is to be appreciated that the AC powered battery embedded CFL wireless light bulb 2500 may be designed in any size or shape housing to meet the requirements of any standard size bulb (e.g. PAR30, PAR38, A19, R30, MR16 etc), non-standard size bulb, fixture, compact fluorescent bulb, fluorescent bulb or lamp (e.g. T4, T5, T8, circular etc.) or down light assembly (e.g. recessed fixtures, fluorescent fixtures or down light fixtures for residential, commercial or industrial lighting), or the like.

[0290] In another illustrative embodiment, an AC powered battery embedded PAR30 wireless light bulb may be AC powered and may contain rechargeable batteries to power the wireless control and light source. With reference to FIG. 26, illustrated is a perspective view of an embodiment of an AC powered battery embedded PAR30 wireless light bulb 2600. In the illustrated embodiment, the AC powered battery embedded PAR30 wireless light bulb 2600 may include a housing 2610, a wireless control module 2620, a thermal heat sink 2630, a plurality of LEDs 2640, a battery holder 2650, an AC/DC converter and power management circuitry 2660, a socket connector 2670, and the like. The size of the embedded battery may be set to match the anticipated power consumption based on the application. The illustrated embodiment is an example of an AC powered battery embedded wireless light bulb system 2300 as described herein. The housing 2610 shown may be a standard PAR30 housing. In an alternate embodiment, the housing may be a custom housing that is larger than the PAR30 housing to accommodate a larger a battery holder 2650 and significantly more battery capacity but still may plug via a socket connector 2670 into any fixture that can accommodate the size of the housing. By way of an example, the housing may be designed to fit into a six inch recessed fixture to use the entire volume of the fixture such that the most battery capacity possible can be used in the application. It is to be appreciated that the disclosed functionality may be designed in any size or shape housing mentioned herein. A wireless control module 2620 may be present. The wireless control module 2620 may be an electrical circuit that contains any type of sensor mentioned herein, an RF/IR receiver or transceiver and/of intelligence to change the state of the AC powered battery embedded PAR30 wireless light bulb 2600. In one example, the wireless control module 2620 may contain a motion sensor and a light sensor and control the light source based on the state of the motion sensor and light sensor. In another example, the wireless control module 2620 may contain an RF receiver and a microcontroller to receive commands from an external entity like a computer, remote control, building management unit, lighting circuit control

unit etc. and control the light source based on the commands received. In another example, the wireless control module **2620** may contain an acoustic sensor that controls the light source based on any sound detected.

[0291] In the illustrated embodiment, the wireless control module **2620** is shown above the thermal heat sink **2630**. In the embodiment, the wireless control module **2620** may be an electrical circuit on a printed circuit board mounted to the thermal heat sink **2630** with screws, nails, fixing posts, flanged heads of fasteners, and other known mounting devices. The wireless control module **2620** may be mounted to a cover that is mounted to the heat sink. In the illustrated embodiment, the cover may be constructed of plastic. Alternately, the cover may be constructed of metal or any other known material. The advantage to mounting the wireless control module **2620** above the heat sink is that the position allows the sensor or antennas of an RF transceiver to be exposed above the heat sink. The AC powered battery embedded PAR30 wireless light bulb **2600** may contain a method to shield or insulate the wireless control module **2620** from heat from the thermal heat sink **2630**. The wireless control module **2620** may have diminished performance or reduced usable life when used at a higher operating temperature. For example, in the example where the AC powered battery embedded PAR30 wireless light bulb **2600** contains a motion sensor and a light sensor, the passive infrared (PIR) sensor that can detect motion may have diminished performance if operated at a higher temperature. The heat shield or insulator may be mounted to the heat sink or plastic cover such that it is situated between the wireless control module **2620** and thermal heat sink **2630**. The heat shield or insulator may be constructed of ceramic, fiberglass or any other known material. In an alternate example, the wireless control module **2620** may be mounted to the cover with some space left between wireless control module **2620** and the thermal heat sink **2630**. The cover may also have some ventilation holes or other methods to allow the heat to escape and keep the temperature of the wireless control module **2620** and the heat sink as low as possible. The wireless control module **2620** may also be mounted below the heat sink and in such a case the sensor or antennas may need to be separated from the printed circuit board and with some components above the heat sink and some wiring through or around the heat sink to those components. There may also be a heat shield or insulator through the heat sink and above the heat sink to shield or insulate the components above the heat sink and the wiring to the components. By way of an example, a passive infrared (PIR) sensor may need to be located on the face of the AC powered battery embedded PAR30 wireless light bulb **2600** however the accompanying circuitry to amplify the output of the PIR sensor and detect threshold crossing may be done by circuitry on a printed circuit board below the heat sink. In this case, the leads or wires to the PIR sensor may be shielded or insulated through the heat sink and the PIR sensor itself may also be shielded or insulated from heat by a heat shield or insulator as mentioned herein to keep the operating temperature of the PIR sensor as low as possible such that there is no diminished performance because of higher temperature. It is to be appreciated that the wireless control module **2620** can be mounted in any location within the AC powered battery embedded PAR30 wireless light bulb **2600**.

[0292] In the illustrated embodiment, the AC/DC converter and power management circuitry **2660** may contain an AC/DC converter, a charging circuit with rechargeable bat-

teries and power selection and conditioning circuitry implementing functionality as described for the AC powered battery embedded wireless light bulb system **2300**. In an alternate embodiment, the AC powered battery embedded PAR30 wireless light bulb **2600** may also contain a grid tie inverter and implement functionality as described for the grid tied AC powered battery embedded wireless light bulb system **2400**.

[0293] In alternate embodiments, an AC powered battery embedded wireless light bulb system may be implemented such that the primary power source is the embedded battery and the AC input is the secondary power source. Under normal conditions, the embedded battery may always be providing power for the wireless light bulb through a DC/AC inverter and the AC input is used to charge the embedded batteries continuously. In some embodiments the wireless light bulb may include electrical circuitry, a relay, an optoisolator etc. to allow the AC input to be switched in to be used as the power source. With reference to FIG. 27, the block diagram shows an embodiment of an on line wireless light bulb **2700** architecture where the battery may be selected at the primary source and the AC input path may be selected as the power source (on line wireless light bulb AC switched **2710**). In an alternate embodiment, DC power may be present at the switch. In this embodiment, there may be no DC/AC inverter after the battery and where there may be an AC/DC converter in the AC input path after the filter (on line wireless light bulb DC switched **2720**). In another embodiment, there may be a grid tie inverter at the output of the battery to allow stored energy to be returned to the line.

[0294] In embodiments of the AC powered battery embedded wireless light bulb system, there may be a step up DC/DC converter after the one or more battery to step up the voltage such that the output of the one or more batteries may drive one or more chains of LEDs that may have a higher voltage drop requirement than the one or more batteries may provide. In alternate embodiments, there may be a circuit present to provide a constant current supply for the one or more chains of LEDs. In some embodiments, the AC powered battery embedded wireless light bulb may contain circuitry to allow for the shutdown of power from the AC source, the shutdown of charging, the shutdown of drive to the LEDs and/or the control of the current supplied through the LEDs to set light intensity (pulse width modulation, adjustable resistor value etc.). It is to be appreciated that any combination of controls may be implemented. By way of an example, power supplied from the input AC source may be shutdown, but the drive to the LEDs from the battery may be enabled and the current through the LEDs may be adjusted to an intensity level as required by the application. It is to be appreciated that any architecture mentioned here in for an AC powered battery embedded wireless light bulb may contain a DC/DC converter to step up the voltage to the proper level to drive a chain of LEDs. By way of an example, a 6" recessed fixture AC powered battery embedded wireless light bulb retrofit may contain batteries and a DC/DC converter to step up the voltage to drive the one or more LED chains. In another example, a fluorescent tube AC powered battery embedded wireless light bulb may contain batteries and a DC/DC converter to step up the voltage to drive the LEDs. In another example, an External Power Supply with Battery LED recessed fixture may be designed with a DC/DC converter to step up the voltage to drive the required voltage to the recessed fixture. In another example, a DC powered wireless light bulb such as an

MR16 with a 12VDC input, may contain one or more embedded batteries and also contain a DC/DC converter to step up the voltage to drive a chain of LEDs. In embodiments of the an external light socket adapter, AC outlet adapter, an AC outlet replacement, an AC powered device, an AC circuit with embedded battery device designed with batteries embedded, wall switch or lighting control component and the like containing embedded batteries, the device may contain a DC/DC converter to step up the DC voltage to a level required to output a higher DC voltage at its output or to improve the efficiency of the DC/AC inverter at the output.

[0295] In an alternate embodiment of a wireless light bulb powered from only AC power or powered only by battery power, the wireless light bulb may contain intelligence to control the light source based on time of day and may contain a communication interface to communicate with an external device. In this case, the intelligence may be programmed to set the times of day that the AC powered or battery powered wireless light bulb is on or off and what the intensity of the light output is. By way of an example, an AC powered wireless light bulb with a microcontroller containing a real time clock may be programmed to set the intensity of the light output to fifty percent of maximum light intensity during daylight hours when there is some ambient light and to set the intensity of the light output to maximum light output during evening hours when there is little ambient light. This will provide some cost savings in energy usage when lighting needs to be on most or all of the day. It is to be appreciated that there may be any number of changes in the light output and the light intensity may be set to any level from off to maximum light intensity of the wireless light bulb. The communication interface may be any communication interface mentioned herein. The external device communicating with and controlling or programming the wireless light bulb may be a computer running a software program, a custom remote control, a building management unit, a lighting circuit control unit etc. and may have the communication interface allowing it to communicate with the wireless light bulb. In the example that is only powered by battery power, the intelligence may also use battery capacity level to set the light intensity output. In such an example, battery power may be rechargeable or non-rechargeable batteries or fuel cells. It is to be appreciated that any wireless power source or any combination of wireless power sources may be used to supply power to or recharge energy storage in the wireless light bulb in connection with the battery powered wireless light bulb controlled based on time of day.

[0296] In wireless light bulb embodiments containing an AC power source and an embedded battery power source, there may need to be a mechanism in place to communicate to the wireless light bulb when to use AC power and when to use embedded power. By way of an example, the UPS wireless light bulb may operate off of AC power. When AC power is turned off, whether intentionally by a user turning the light switch off or unintentional when there is a power outage etc., the UPS wireless light bulb may automatically switch over to battery power. In an alternate use case, the user may desire that at times the UPS wireless light bulb does not automatically switch over to battery power but rather that the on/off wall switch operates the light and that there be a method to select that the UPS wireless light bulb is enabled to operate in a mode that automatically switch over to battery power. In this alternate case, a slide switch on the UPS wireless light bulb that enables or disables automatic switch over may accom-

modate this function however it may be inconvenient for a user to change the slide switch position (because of the installation location for example in a recessed fixture in the ceiling). An alternate method to enable or disable automatic switch over to battery is by including an RF receiver in the UPS wireless light bulb such that a command enabling or disabling the automatic switch over can be sent via RF to the UPS bulb. Another alternate method to enable or disable automatic switch over to battery is to create a mechanism such that the wireless light bulb detects a sequencing of the power applied to it. By way of an example, if the on/off wall switch is turned on, then off in less than one second, the automatic switch over to battery function is enabled the next time the wireless light bulb is turned on. If the on/off wall switch is turned on, then off in less than one second, then on in less than one second or if the unit is turned on then left on for greater than one second the automatic switch over to battery function is disabled and control of the wireless light bulb is by the on/off wall switch. In such a case, battery power may be used to power the wireless light bulb during the power sequencing or a large capacitor is charged enough that an electrical circuit is powered and can latch the state of the on—off power sequencing such that it may change the mode of the bulb appropriately even in the absence of AC power or if the embedded battery power is discharged and is not usable. It is to be appreciated that any number of power cycles may be done to put the wireless light bulb in any number of modes it may operate in and any type of wireless power source or sources in the wireless light bulb may be controlled. The on/off wall switch may contain circuitry and an alternate way to select the mode such that the power sequencing is transparent to the user. For example, there may be a slide switch on an on/off wall switch that selects the mode. When the user turns the on/off wall switch on, the electrical circuit inside the on/off wall switch sequences the power appropriately to set the mode of operation. In an alternate embodiment, there may be a real time clock and intelligence inside the UPS light bulb such that it may be programmed to use one mode of operation during certain times of the day and another mode of operation during other times of the day. By way of an example, the user may program the UPS light bulb to be in UPS mode during the day when the user knows the light needs to be on even in a power outage, however it may change modes to switch control or automatically shut off and enter switch control mode during times of the day when the user knows the lights should be off.

[0297] In wireless light bulb embodiments containing an AC power source and a sensor or RF/IR control, there may need to be a mechanism in place to communicate to the wireless light bulb when to use the sensor or RF/IF control the wireless light bulb and when to use the on/off wall switch to control the wireless light bulb. By way of an example, the AC powered wireless light bulb may have a motion sensor that may turn the bulb on when motion is detected. In an alternate use case, the user may desire that at times the AC powered wireless light bulb does not automatically turn on when motion is detected but rather that the on/off wall switch operates the light and that there is a method that the AC powered wireless light bulb may be enabled to operate in a mode that uses the motion sensor to control the light. In this alternate case, a slide switch on the AC powered wireless light bulb that enables or disables motion detection control (and that when the bulb is turned on it is always on) may accommodate this function however it may be inconvenient for a user to change

the slide switch position (because of the installation location for example in a recessed fixture in the ceiling). An alternate method to enable or disable motion detection control is by including an RF receiver in the AC powered wireless light bulb such that a command enabling or disabling the motion detection may be sent via RF to the AC powered wireless light bulb. Another alternate method to enable or disable motion detection control is to create a mechanism such that the wireless light bulb detects a sequencing of the power applied to it. By way of an example, if the on/off wall switch is turned on, then off in less than one second, then on in less than one second motion detection is enabled. If the unit is turned on and left on for greater than one second, the control of the wireless light bulb is by the on/off wall switch (i.e. it remains on whether there is motion or not and is turned off by the on/off wall switch). When the unit is turned off and left off for a period of time, the next time the on/off wall switch is used, it can again set the mode of the wireless light bulb. In such a case, it may be required that a small amount of power storage exists in the wireless light bulb, for example small battery is present or a large capacitor is charged enough that an electrical circuit is powered and can latch the state of the on—off power sequencing such that it may change the mode of the bulb appropriately even in the absence of AC power briefly. It is to be appreciated that any number of power cycles may be done to put the wireless light bulb in any number of modes it may operate in and any type of sensor or sensors in the wireless light bulb may be controlled. The on/off wall switch may contain circuitry and an alternate way to select the mode such that the power sequencing is transparent to the user. For example, there may be a slide switch on an on/off wall switch that enables or disables motion detection. When the user turns the on/off wall switch on, the electrical circuit inside the on/off wall switch sequences the power appropriately to set the mode of operation. In an alternate embodiment, there may be a real time clock and intelligence inside the wireless light bulb such that it may be programmed to use one mode of operation during certain times of the day and the other mode of operation during other times of the day. By way of an example, the user may program an AC powered motion sensor wireless light bulb to be controlled by a motion sensor during the evening hours when the user knows there is typically low occupancy, however it may change modes to wall switch control during times of the day when the user knows the lights should always be on due to typically high occupancy. In another example, the AC powered motion sensor wireless light bulb may have an embedded battery such that the user may also be able to select the power source based on time of day.

[0298] In wireless light bulb embodiments containing an AC power source, an embedded battery power source and/or other wireless power sources, there may be many reasons to switch from one power source to another or to have power sources share the load. The reasons to switch from one power source to another or to have power sources share the load may be sensor or RF/IR controlled, controlled by intelligent decision and/or controlled by power management functions. In the case of sensor or RF/IR control, the switch over may be based on motion detection, light detection, power consumption measurements or any other sensor parameter that may necessitate a switch to a different power source. For example, an AC powered battery embedded wireless light bulb may have a glow or low light function that is powered by battery, but when motion is detected, the bulb turns on to full bright-

ness and is powered by AC power. In the case of control by intelligent decision, intelligence in the wireless light bulb (microcontroller, microprocessor, integrated circuit etc.) may control the bulb based on time of day or timers, knowledge gained over time based on monitoring of sensors, a user program based on a knowledge of the use patterns required for a particular wireless light bulb, an individual profile based on an identification from the area (detect an RFID personnel tag on an individual for example) etc. For example, an AC powered battery embedded wireless light bulb may have a motion sensor in it and a real time clock. Over a number of days a microprocessor may build a profile of occupancy based on motion detections recorded at particular times of the day that it may plug into an algorithm to automatically set the light intensity to a very low level running off of battery power when it is apparent that there should be no motion detected or it may anticipate when it should detect motion and switch to AC power and turn on to full intensity prior to that time (for example first thing in the morning at an office a few minutes prior to when the first employee is expected to show up based on the profile of occupancy built by the microprocessor). In the case of switch over controlled by power management functions, the control of power source to use may be due to low battery capacity, AC not being present or not being usable, whether a wireless power source is present and is usable (solar cells collecting enough energy to share the load), depth of discharge thresholds to manage the life cycle of rechargeable batteries, the sharing of the load by power sources to optimize energy use for cost savings or conservation purposes etc. By way of an example, solar cells in a wireless light bulb may generate enough power to share the load at any time. If the wireless light bulb monitors the solar power source and determines that it is an appropriate power source to use based on the power consumption requirements, it may use the solar power source exclusively or may share the load between multiple power sources including the solar power source.

[0299] In wireless light bulb embodiments containing an AC power source, an embedded battery power source and/or other wireless power sources, there are a number of methods by which the load is shared by the sources (i.e. some amount of power required by the load is supplied by more than one source). It has been mentioned that the sources may be diode ored prior to the load as one method of placing power sources in parallel. Other methods of paralleling power sources to source power to the load may include circuits with diodes, FETs, transistors, op amps, power converters and the like. Once the power sources are paralleled such they may independently supply power to the load, there may also be control to determine the amount of power each source may deliver. By way of an example, there may be two power sources for a light source (chain of LEDs etc.)—an AC power source and an embedded battery power source. The output of the AC power source and the embedded battery power source are diode ored prior to the light source such that they may both supply power to the light source. The output of the embedded battery power source may be followed by a constant current source circuit that may be adjusted to any current level required from zero percent of the power supplied to the light source to one hundred percent of the power supplied to the light source. There may be circuitry to measure the amount of current flowing through the LEDs and there may be circuitry to measure the amount of current flowing through the constant current at the output of the embedded battery source. If

the application requires that fifty percent of the load is delivered by the embedded battery source, the constant current supplied by the embedded battery source may be adjusted until the amount of current supplied is fifty percent of the measurement of current flowing through the chain of LEDs. By way of an example, a microcontroller with the ability to take an analog to digital measurement at the constant current circuit at the output of the embedded battery source and at some point in the chain of LEDs, then adjust the amount of current at the constant current circuit (by setting the value of a digital potentiometer or the like) until the desired ratio of load sharing is achieved. In an alternate embodiment, the output of the embedded battery source is connected to an LED driver circuit that may drive a chain of LEDs and also has the capability of control by pulse width modulation that controls the percentage of current supplied from the embedded battery source. In alternate embodiments, the amount of power supplied by the AC power source is controlled. The AC power source may have a constant current circuit at the output, may be a constant current source by design and have the ability to adjust the amount of current supplied by pulse width modulation and the like. The embedded battery power source would supply the remainder of the power to the load. It is to be appreciated that any number of power sources may be used in connection to the claimed subject matter.

[0300] In an illustrative embodiment shown in FIG. 28, the block diagram shows an example AC powered super capacitor embedded wireless light bulb system 2800 that may use an AC power input and a super or ultra capacitor power source with an intelligent, programmable controller to provide cost savings, security and convenience benefits to a lighting installation. In the illustrated embodiment, the AC powered super capacitor embedded wireless light bulb system 2800 may include an AC/DC converter 2810, one or more super or ultra capacitors 2820, power selection and conditioning circuitry 2830, an intelligent, programmable time of use and power source controller 2840, a light source or load 2850, a communication interface 2860, and the like. The AC input may be connected to the AC powered super capacitor embedded wireless light bulb system 2800 by a light socket, wall outlet, terminal block, connector, hardwired connection or any common connection that a device requiring AC power may have to provide an AC power input. The AC input block may contain a transformer, line cap, fuse, inrush limiter or other type of power circuitry commonly found at the input of an AC/DC converter or an AC powered device. By way of an example, an inrush limiter may be used to guarantee that the inrush current does not exceed a certain threshold especially with a large capacitance potentially charging when AC power is first applied. The output of the AC/DC converter 2810 may be a regulated DC source such as a DC/DC converter circuit. It may be a constant current source to the load for example to provide constant current to a chain of LEDs in series. In some embodiments there may be multiple circuits at the output of the AC/DC converter such that one circuit may provide a power source for low current draw circuitry such as for an intelligent, programmable time of use and power source controller 2840 communication interface 2860, and the like, and where a second circuit may provide a power source for high current draw circuitry such as the light source or load 2850. It is to be appreciated that any number power sources may be created at the output of the AC/DC converter to meet the needs of the application.

[0301] The output of the AC/DC converter may be connected to one or more super or ultra capacitors 2820. The large capacitance at the output of the regulator may provide power to the light source or load 2850 in the absence of AC input power. The larger that the capacitance in the capacitor or bank of capacitors, the longer that the capacitance at the output of the regulator may power the circuit. It is to be appreciated that the one or more super or ultra capacitors 2820 may be in series, parallel or any combination as required by the application. The one or more super or ultra capacitor 2820 may charge when AC input is available. The power source controller may control the regulator to disable it such that even if the AC input is available, the circuitry will be powered by one or more super or ultra capacitor 2820. The power source may pulse width modulate the control of the regulator to accomplish any amount of load sharing between the AC input and the one or more super or ultra capacitor 2820. In an alternate embodiment, the one or more super or ultra capacitors may be in the AC/DC controller prior to the regulator and there may or may not be one or more super or ultra capacitors 2820 after the regulator. In this case, the capacitance in the AC/DC controller may provide the filtering for the output of the rectifier circuit but will also be able to provide a power source to the circuit in the absence of AC input power for some period of time. In alternate embodiments, there may also be a rechargeable battery and charging circuit after the regulator in addition to the one or more super or ultra capacitors 2820. The combination of a rechargeable battery and large capacitance as a rechargeable power source may allow the design to contain the positive aspects of both approaches. The capacitive energy storage will charge and be available quickly whereas rechargeable batteries will provide a lot of storage for a low cost.

[0302] In some RF or IR transmitter embodiments, the RF or IR transmitter may rely on energy harvesting techniques to power or charge the device. For example, a transmitter in a housing that can mount to a wall may contain one or more solar cells, a large capacitor, a microcontroller, an RF transmitter, and the like. The microcontroller and RF transmitter may typically be in a low current sleep mode. The solar cells and capacitor may be sized to provide enough energy storage and recharge capability such that the switches on the RF transmitter may be pressed several times sending commands to a wireless light bulb or battery powered wireless light fixture before the capacitor cannot supply enough energy to transmit the command. Under normal usage, the solar cells and capacitor may contain enough power and recharge capability such that there may not be an instance that the button would be pushed and not transmit a command. In an alternate embodiment, instead of a solar cell, a piezoelectric device may be designed on a handheld transmitter such that energy is harvested from the motion of the device. In this case, when the user waves the piezoelectric powered device in the direction of the light with a button pressed, the device may transmit a command to turn the light on or off. In another example, perhaps a button does not need to be pushed and that the waving of the device may transmit a toggle command when enough energy is harvested from the motion to toggle the state of the light. It is to be appreciated that any form of energy harvesting may be used in conjunction with the RF or IR transmitter concepts mentioned herein.

[0303] In another RF or IR transmitter embodiment, a wireless light bulb or battery powered wireless lighting fixture may be controlled by a remote light sensor with an RF trans-

mitter. The measured light level may be periodically transmitted to one or more wireless light bulbs or battery powered wireless lighting fixtures. The wireless light bulb or battery powered wireless lighting fixture may contain an RF receiver and an intelligent device such as a microcontroller that may allow the measured light level to be interpreted and such interpretation may lead to a state change. By way of an example, a wireless light bulb or battery powered wireless light fixture may be installed in a hallway that receives some ambient light from windows or other lights in the area. The desired light level may be programmed into the wireless light bulb or battery powered wireless lighting fixture. The remote light sensor may be placed on the floor or wall of the hallway below the light that is to be controlled. Every five seconds, the light sensor with an RF transmitter may transmit the measured light level to the wireless light bulb or battery powered wireless lighting fixture. When received, the light intensity may be left unchanged, adjusted up or adjusted down automatically to set the light intensity to be at a preprogrammed level or range. In an alternate embodiment, the remote light sensor is a handheld device that a user may use to set the light intensity level for the daylight harvesting function where the light intensity is set based on the ambient light level detected such that the ambient light plus the light generated by the light source maintain a constant light level. In this embodiment, the user may walk into a room with the remote light sensor handheld device and press a button to take a reading. The remote light sensor handheld device may have a transmitter such that it may transmit the reading to the wireless light bulb battery powered wireless lighting fixture. The wireless light bulb battery powered wireless lighting fixture may be programmed by the transmission or it may use the detected light level information to set its light intensity level appropriately. Alternately, the user may use an alternate method to enter the detected lux reading into the wireless light bulb or battery powered wireless lighting fixtures. For example, the user may open a graphical user interface with a software application that would allow the user to enter the settings for the daylight harvesting functions as well as the detected light levels. There may be net light values based on time of day or any other input to the unit that user may desire a different net light value. In another example, the user may manually adjust the constant light level using a control, such as a dial, on the RF transmitter, on the wireless light bulb or on the battery powered wireless lighting fixtures based on the reading.

[0304] In some embodiments, there may be multiple remote light sensors and multiple wireless light bulbs or battery powered wireless lighting fixtures in the same area. By way of an example, in a conference room, multiple PAR38 wireless light bulbs may be installed in recessed fixtures. In this example, three remote light sensors are placed in the conference room on top of each end of and on top of the center of the conference room table. The multiple wireless light bulbs may receive the light intensity measurements and adjust the light intensity output as programmed. Unique IDs may be set in each of the wireless light bulbs such that all wireless light bulbs may receive all remote light sensor transmissions or the wireless light bulbs and remote light sensors may be grouped in areas by setting the unique IDs to create operational groups. In some embodiments, the user may have a separate remote controller that may allow programming the wireless light bulbs or battery powered wireless lighting fixture to respond in different ways to the remote light sensor input. The remote controller may have multiple scenes pro-

grammed in. In the conference room example, there may be a presentation scene where there are different light intensities in different parts of the room or there may be a meeting scene where the lights are set to high light intensity throughout the room. The remote controller may allow methods to create scenes and program the details (light intensity, timing, time of day response, groups of lights etc) into the wireless light bulbs. The remote controller may have a method to override the use of the remote light sensors and allow a user to directly control the light intensity of one or more wireless light bulbs or battery powered wireless lighting fixtures.

[0305] A daylight harvesting kit may be constructed consisting of an AC powered wireless light bulb with a receiver and a remote light sensor transmitter. There may be a control on the AC powered wireless light bulb or on the remote light sensor transmitter to set the net light level that a user desires or it may be programmed in some other manner over the communication interface. A user may install the wireless light bulb and place the remote light sensor transmitter in a location where the user wants a net light value to be maintained. The user then turns on the wireless light bulb and sets the net light value through the means of control provided. Thereafter the wireless light bulb may receive periodic transmissions from the remote light sensor transmitter and adjust its light intensity appropriately.

[0306] In some embodiments a wireless light bulb or wireless lighting module may be controlled by a light sensor designed into the unit. In such a case a daylight harvesting function may be implemented where the light intensity generated by the light source is set based on the ambient light level detected such that the ambient light plus the light generated by the light source maintain a constant light level. The net amount of light may be set by a user either by programming the net light value into the wireless light bulb or wireless lighting module through a programming method over the communication interface or it may be set directly on the unit through a method of control such as a dial, push buttons, slide switches and the like where a user may set the net light they desire directly and thereafter the wireless light bulb or wireless lighting module will adjust the output light intensity to maintain the detected light level at the user setting. In alternate embodiments, there may be more than one net light setting where the selection of which light intensity setting to use is based on time of day, inputs from other forms of wireless control designed into the bulb, intelligent decisions made based on inputs to the wireless light bulb or wireless lighting module such as battery charge level and the like. In order to measure the amount of ambient light in the area, the wireless light bulb or wireless lighting module may turn off the light source, read and analyze the ambient light measurement, then set the light intensity of the light source. The wireless light bulb or wireless lighting module may store the net light setting in memory inside the unit such that when power is turned off the user setting is not lost. In the case where there is a dial, push buttons, switches and the like on the unit, the unit may read and analyze those inputs as needed to set the desired net light value. It is to be appreciated that the daylight harvesting function may be used in conjunction with any form of wireless control or any intelligent function mentioned herein.

[0307] By way of an example, a wireless light bulb may contain a light sensor and a dial on the light sensor to set the net amount of light. The user may install the wireless light bulb, turn it on, then turn the dial on the bulb until the amount

of light generated is what the user desires. Thereafter, whatever amount of ambient light that is detected, the bulb will automatically set the light intensity to provide the desired light output. In another example, a battery powered RF controlled LED spotlight contains a light sensor and a slide switch that allows multiple net light settings to be selected. The spotlight may then set the light output based on the desired net light value and the detected ambient light level. When the user turns on the spotlight via a remote control, the spotlight may then read and analyze the input from the light sensor, then set the light intensity of the output appropriately to meet the net light value. In another example, an AC powered battery embedded wireless light bulb designed to retrofit into a 6" fixture contains a light sensor. Intelligence in the unit may store energy in the rechargeable battery during off peak hours and use the battery to power the light source during on peak hours. If the unit implements a daylight harvesting function, battery life may be extended and the user may then continue to get the desired net light, thus the lighting installation may operate as necessary and there may be a cost savings through controls.

[0308] In another embodiment, a wireless light bulb or wireless lighting module may contain a light sensor and the ability to adjust the light output to compensate for the deterioration of LED performance over the life of the bulb. It is known that LED performance may deteriorate over time. The light sensor may be used to help ensure that the light output remains consistent, such as by increasing the drive current to the LEDs based on the detected light level. In an alternate embodiment, the wireless light bulb or wireless lighting module may contain only a timer or real time clock internally and may keep a record of the number of hours the wireless light bulb or wireless lighting module has been used. Based on the number of hours the LED light source has been illuminated, the wireless light bulb or wireless lighting module may contain the intelligence to increase the drive current to the LEDs based on an algorithm that predicts the rate of deterioration in the performance of the LEDs. In some embodiments, the user may have access to the stored information of number of hours of on time and drive level such that a user may determine the health or level of performance of the LEDs at any time. In an alternate embodiment, the wireless light bulb or wireless lighting module may contain a transmitter such that it may transmit the performance information to a processor to keep a record of the performance and/or for analysis.

[0309] In one embodiment, a wireless light bulb or wireless lighting module may contain an array of light sensors (CdS or photodiodes) sensitive to different bands of light wavelength such that it may be used to create a "spectrum analyzer" of light in the desired band. This may be designed into a wireless light bulb, wireless lighting module or it may be a separate unit with a transmitter that may detect the information of the spectrum and transmit the information to a wireless light bulb or wireless lighting module containing a receiver. The wireless light bulb or wireless lighting module may use the information to adjust the color of the output light to meet a specific light or wireless lighting module spectrum envelope. By way of an example, an array of eight CdS sensors occupying consecutive parts of the band of visible light from 2800K to 4400K, with the first sensor measuring lux from 2800K to 3000K, the second sensor measuring lux from 3000K to 3200K and so on. The measured spectrum of light may then be used to set the mix of red, green and blue LEDs to create the desired spectrum of light output. In some embodiments,

this sensor may be used to provide the user with different light options, such as tungsten, natural light, candle light, fluorescent, and such, to match the user's preference, or to match the other lights in the vicinity.

[0310] In another illustrative embodiment, a version of the wireless light bulb is used in External Power Supply with Battery LED recessed fixture **2900** applications. With reference to FIG. **29**, illustrated is a perspective view of an embodiment of an External Power Supply with Battery LED recessed fixture **2900**. In the illustrated embodiment, the External Power Supply with Battery LED recessed fixture **2900** includes a housing **2910**, an AC input **2920**, an external power supply for AC/DC conversion and battery management functions **2930**, a DC input **2940**, a printed circuit for wireless control and LED drive circuitry **2950**, a plurality of LEDs **2960** and a heatsink **2970**. In this embodiment, the AC/DC power supply and batteries are external to the housing, electronics, thermal management and light source. The batteries may be rechargeable or non-rechargeable and may be internal to the housing of the AC/DC power supply. In alternate embodiments, the batteries may be external to the housing of the AC/DC power supply and are electrically connected to the power supply. In alternate embodiments, the AC/DC power supply and batteries may be external to the recessed fixture and may both be connected to the fixture. In such an embodiment, electronics for wireless control and LED drive circuitry **2950** may make an intelligent decision on which power source to use. It is noted that the External Power Supply with Battery LED recessed fixture **2900** may be designed in any size or shape housing **2910** to meet the requirements of any standard size bulb (PAR30, PAR38, A19, R30, MR16 etc), non-standard size bulb, fixture, fluorescent bulb or lamp (T4, T5, T8, circular etc.) or down light assembly (recessed fixtures, fluorescent fixtures or down light fixtures for residential or industrial lighting), or the like. It is noted that the external power supply may be designed in any size or shape to meet the requirements with typical characteristics of an AC input, DC output and in the case where external batteries are used a connection to those batteries. The external power supply may have intelligence built in to make a decision to use the AC input, internal or external batteries or both to power the External Power Supply with Battery LED recessed fixture **2900**. In alternate embodiments, the external power supply may have a grid tie inverter and associated circuitry designed in such that it may return stored energy to the grid as described herein. In alternate embodiments, the external power supply is replaced by a ballast for fluorescent lighting applications. In such a case there may be rechargeable or non-rechargeable batteries internal to the housing of the ballast. In alternate embodiments, the batteries may be external to the housing of the ballast and are electrically connected to the ballast where the ballast contains the intelligence to select the power source. In an alternate embodiment, there is a controller separate from the ballast that works in conjunction with the ballast to control the lighting. In such a case there may be rechargeable or non-rechargeable internal to the housing of the controller. In alternate embodiments, the batteries may be external to the housing of the controller and are electrically connected to the controller. In such an embodiment, the controller may contain wireless control or an intelligent device in the form of a microcontroller, microprocessor, integrated circuit etc to make an intelligent decision on storing power in the batteries and which power source to use.

[0311] In some wireless light bulb or battery powered wireless lighting fixture embodiments, there may be an LED on the bulb or fixture that the battery capacity is below a threshold (battery low indication) or that there may be a fault condition in the bulb or fixture. An LED may be a colored LED and it may display status in by being on solid or blinking in some manner that may provide an indication of the nature of the fault condition. An LED may provide a positive indication also. By way of an example, a green LED may be on a bulb or fixture to indicate that the battery level is good. A multicolored LED may be used to provide multiple indications. By way of an example, when the LED is green, the battery level is good, when the LED is yellow the battery level is marginal and when the LED is red the battery level is too low. In alternate embodiments, there may be a transmitter on the wireless light bulb or battery powered wireless lighting fixture that may transmit an indication of the status of the bulb or fixture to a receiver that can process and make use of the indication. By way of an example, in a safety lighting system that contains battery embedded power, the bulb or fixture may transmit an indication of a low battery level to a central controller to allow the battery to be changed or guarantee that the battery may be recharged. A network of bulbs or fixtures may be used to forward the transmitted indications back to a central controller to process the information.

[0312] In some embodiments, a wireless light bulb may be connected an AC input that is triac dimmer controlled. In this case, the wireless light bulb may detect a zero crossing of the AC waveform, may be able to determine the amount of the waveform that has been shut off by the triac and may adjust a PWM dimming control to one or more LEDs such that the triac dimmer control that is in a wall switch or similar device may still control the intensity of the light output. In a triac dimmer control, the power delivered to the wireless light bulb may be enough to power the wireless light bulb even if a portion of the power delivered to the wireless light bulb is eliminated by the triac. By way of an example, the dimming function for the wireless light bulb may work down to a level where only twenty percent of the power is delivered to the wireless light bulb because the power after the diode bridge and prior to a regulator circuit may still be enough to provide power to the light source and circuitry in the wireless light bulb. In this example, the light intensity controlled by the PWM control of the one or more LEDs may set the light intensity to zero output when only twenty percent of the AC input waveform is detected by the wireless light bulb. From twenty percent to one hundred percent of the waveform, the dimming levels will be set in the PWM control to provide a full dimming range for the wireless light bulb. In alternate embodiments, there may be also an alternate power source available in the wireless light bulb such as batteries or a super capacitor that allows the AC input detection circuitry and intelligence in the wireless light bulb to operate even when the AC input is below a threshold that would power the wireless light bulb. In such a case, the wireless light bulb may use the AC input as long as it has determined that it is acceptable for use, but then switch over to the alternate power source when it is not acceptable to use. The alternate power source may be used to power the light source and control circuitry all of the time and the AC input with triac dimmer control may only used to allow the wireless light bulb to detect the waveform to set the PWM control of the LEDs to achieve the desired light intensity and to recharge the batteries. In some embodiments, the triac dimming control wall switch plate may be replaced

by an RF transmitter wall switch plate with dimming controls that send dim up and dim down commands to one or more wireless light bulbs with RF receivers allowing them to perform the PWM dimming control to set the light intensity.

[0313] Preset lighting zones and scenes may be programmed into a wireless light bulb or battery powered wireless lighting fixture to allow a user to select a specific light intensity or setting. The lighting zones and scenes may be preprogrammed (as part of a specific embodiment of a bulb or fixture with settings that a user would typically require for certain applications) or they may be setup and programmed by the user. Lighting zones may be set up using unique IDs such that some of the bulbs or fixtures in a certain area may operate similarly.

[0314] In some battery powered wireless light bulb or battery powered wireless lighting fixture embodiments, there may be energy harvesting methods employed to supplement and recharge embedded battery power. In one use case, a wireless light bulb parking lot light or street lamp may be designed that may harvest wind power to power the light source and control circuitry and/or charge embedded battery power. In the example use case, a small wind mill is built inside the housing of the parking lot light or street lamp. The housing has openings to allow wind to turn the mechanism, but the wind mill is not visible. In some embodiments, the wind mill may be visible. The wind energy is converted to electrical energy and either directly powers the light or is stored in the embedded battery. The parking lot or street lamp may or may not have an AC power source in addition to the wind power and embedded battery power sources. In alternate use cases, energy is harvested from a turnstile, for example at a subway station or sporting event. The spinning motion of the turnstile generates electricity that powers the light source and control circuitry and/or charges embedded battery power. In another use case, the wireless lighting module is similar to a collar that opens and closes. When closed it may be locked onto whatever it closes on. The inside portion spins and the outside portion remains fixed. By way of an example the wireless lighting module may be affixed to the roof of a revolving door with screws or another attachment mechanism and the inner portion is attached to the spinning part of the revolving door. The outside portion has the light in it, the inside portion spins with whatever it is attached to and generates electricity as it spins. In this use case, the wireless lighting module may be attached to anything that is spinning to generate electricity for use by the wireless lighting module. This may be used in revolving doors, carousels, turnstiles etc. In alternate use cases, the wireless lighting module may mount to a pole and blades may be attached to the spinning portion to allow for wind energy to be converted to electrical energy to power and/or charge batteries in the wireless lighting module.

[0315] In some use cases the wireless lighting module may be designed to harvest energy from the opening and closing of a door. When the door is opened or closed, a porch light that is outside of the door stores energy via electromagnetic induction or any other energy harvesting method from the opening and closing of the door. In another use case, a computer keyboard may be designed with a piezoelectric device under each key such that when the key is pressed, electricity is generated. An electrical circuit may be wired from the keyboard along with the keyboard connection to the computer to a wireless lighting module in the form of a desk lamp that may be powered from the electricity harvested from the key

presses. The desk lamp may contain rechargeable batteries to store the energy generated by the key presses. In another use case, a wireless lighting module may be designed such that a portable water mill may be placed in flowing water and cabled to a wireless lighting module in the form of a path light or spotlight mounted to the ground with a stake. The wireless lighting module may contain rechargeable batteries to store energy for later use. The wireless lighting module may contain an RF receiver such that it may be controlled with a remote control to turn the light on or off as needed. In alternate use cases, a similar wireless lighting module may be used on a boat as a power source and charging source for wireless lighting modules on the boat. As the boat moves through the water, electricity may be created to power the light on the boat.

[0316] In some wireless light bulb or battery powered wireless lighting fixture embodiments, there may be a receiver control module such that the same design of light source, thermal management, AC/DC circuit, regulator circuitry, housing, battery management etc may be used, but the wireless control and embedded intelligence may change to use different communication interfaces, different types of sensors, different types of embedded intelligence or different types of LED control and power management. This may allow changing from one control type to another (LEDs, thermal, AC/DC etc stay same, lighting control module changes to allow the bulb or fixture to be part of different control topologies). By way of an example, a receiver control module may be a printed circuit board containing intelligence (microcontroller, microprocessor, integrated circuit etc.), a communication interface, battery charging and control circuitry, light source drive and control circuitry, and the like. For example, one module may be designed for a wireless light bulb that uses ZIGBEE as a communication interface. An alternate module may be designed for a wireless light bulb that uses BLUETOOTH as a communication interface in a printed circuit board that may be the same form factor as the ZIGBEE based receiver control module. An alternate module may be designed for a wireless light bulb that uses the ENOCEAN protocol as a communication interface in a printed circuit board that may be the same form factor as the ZIGBEE based or BLUETOOTH based receiver control module. In those three cases, the base wireless light bulb design may remain the same, but the receiver control module may be changed to create three wireless light bulb options that could be integrated with different system architectures. In another example, the receiver control module with a real time clock embedded may be installed to control the light source based on time of day. Alternately, the receiver control module that may receive and forward commands in a mesh network may be installed to create a mesh network of wireless light bulb or battery powered wireless lighting fixture. It is to be appreciated that the receiver control module may contain any combination of intelligence, communication interfaces, sensors, battery charging and control circuitry and light source drive and control circuitry mentioned herein. In some embodiments the module may be referred to as a sensor control module as it may provide sensor functions that may operate with or without a communication interface. In some embodiments, the module may be referred to as a transceiver control module as it would contain a transmitter and receiver such that the module may transmit, receive and in some embodiments be part of a network of wireless light bulbs or battery powered wireless lighting fixtures. In other embodi-

ments, the module may be an intelligent control module that may provide intelligent function such as programmable time of day control. It is to be appreciated that a module may be designed that contains any mix of functionality of the modules mentioned herein.

[0317] In some embodiments, the receiver control module may be built into the wireless light bulb or battery powered wireless lighting fixture. In other embodiments, the receiver control module may be replaceable by opening the wireless light bulb or battery powered wireless lighting fixture, removing receiver control module and replacing it with a different receiver control module. In this case, the receiver control module may have a connector to allow it to make electrical and mechanical connection to the bulb or fixture. In other embodiments, the receiver control module is external to the bulb or fixture and is in its own housing of any size or shape as required by the application. In this case, there may be a connector on the bulb or fixture and on the receiver control module to allow it to be plugged into or unplugged from the bulb or fixture. It is to be appreciated that the receiver control module may be changeable in place (i.e. it may be reprogrammed over the communication interface such that the same hardware provides a different set of functionality).

[0318] In embodiments of the wireless light module or apparatus where there is a wireless power source, there may exist the capability that the wireless lighting module or apparatus may be removed from its installed location and used as a mobile light source (i.e. carried around, attached to a vehicle etc). In some embodiments, the entire wireless lighting module or apparatus may be a mobile light source, but in other embodiments some part of the wireless lighting module or apparatus may be removed and used as a mobile light source. By way of an example, an LED spotlight with any type of wireless power and wireless control source may be installed at any location. If desired, a user may remove the LED spotlight or a portion of the LED spotlight from its installed location and walk around with the spotlight using it as a light source. In one example, the LED spotlight is attached to a tree without driving into the tree to mount the spotlight.

[0319] In embodiments, a wireless lighting module or wireless light bulb may use a real time clock to maintain timer or time of day information for use by intelligent functions. In alternate embodiments, a wireless lighting module or wireless light bulb may maintain timer or time of day information through the use of a microcontroller, microprocessor, integrated circuit etc. that may keep track of time independently or with an associated crystal oscillator, clock oscillator, electrical circuit that oscillates or the like. An external time source may be used to calibrate or update the timer or time of day clock to synchronize with the external time source to set the internal time source and/or compensate for clock drift of the internal time source. In alternate embodiments, a module or bulb may use an atomic clock receiver inside the module or bulb to receive accurate and reliable time of day clock from a clock source provided by a radio transmitter. By way of an example, the transmitting clock source may be the WWV or WWVB radio controlled clocks that are transmitted by the NIST time signal radio station or the like. In such a case, a user may not need to set the time of day. It may be set automatically by receiving a radio signal containing clock information that may be used to update the time of day information kept in the module or bulb. In such a case, the module or bulb will be able to regularly update its internal clock to keep it as accurate as possible. It may also be able to auto-

matically adjust for daylight savings time changes. In some embodiments, a module or bulb that may be able to receive atomic clock information may retransmit it to other stations that cannot receive the atomic clock information for any reason. In this case, a network of wireless lighting modules or wireless light bulbs may benefit from the distribution of time of day information that is distributed through the network. In alternate embodiments, Network Time Protocol (NTP) or any other time distribution protocol may be used to distribute timer and/or time of day information in a network of wireless lighting modules and wireless light bulbs. By synchronizing modules and bulbs to a common clock, complete lighting installations will be able to operate synchronized in time. In addition, in a case where intelligence inside the modules and bulbs will be used to change state at particular times or times of day, a synchronized clock across the network may allow them to do so independently, but still synchronized in time. In alternate embodiments, the wireless light module or wireless light bulb may contain an astronomical time clock that maintains day, date, sunrise, sunset and daylight savings information to allow the module or bulb state to be changed based on the information from the astronomical time clock.

[0320] In another embodiment, a version of the wireless lighting module may target wireless LED spotlight applications where there is a mounting mechanism to mount the spotlights to support bars of a drop ceiling. In an alternate embodiment, there is a mounting mechanism to mount the spotlights directly to the ceiling, wall or under cabinet. In either case, the spotlight has the ability to have the direction of the light source changed. Thus, one or more wireless LED spotlights may be used to be installed similar to track lights but use wireless power therefore they may be installed in any location the user desires ("wireless track light"). By way of an example, a wireless track light may be created by one or more wireless LED spotlights that illuminate an area of approximately one hundred fifty square feet. Alternate embodiments may include but are not limited to any known light source including LEDs, compact fluorescent, incandescent bulbs, and the like, and can illuminate any size area required by the application.

[0321] The wireless track light may include one or more wireless power sources such as a battery. By way of an example, the wireless track light may consist of one or more spotlights powered by 3 D batteries. It should be understood that in alternate embodiments any number and type of known batteries may be used, including without limitation all known alkaline and nickel-cadmium batteries, depending on size and power requirements. According to another example, the power source may be any number and type of rechargeable batteries and/or non-rechargeable batteries. Pursuant to a further illustration, the power source may be a combination of a solar cell and one or more batteries (e.g., rechargeable, non-rechargeable). Thus, for instance, a battery can supplement the power supplied by the solar cell (or vice versa) and/or the solar cell can recharge a battery.

[0322] In embodiments, the wireless power source may supply power to the spotlights to enable installing, moving, replacing, etc. the wireless track light at substantially any indoor or outdoor location while mitigating the need for expensive and time consuming wiring and/or utilization of aesthetically displeasing and potentially inconvenient cords commonly associated with conventional lighting. In alternate embodiments the power source may include a fuel cell, such as and without limitation a hydrogen fuel cell, a reformed

methanol fuel cell, or the like. In alternate embodiments, the power source may include a capacitor, array of capacitor, super capacitor, and the like, to store energy to be used as a power source similar to a battery. There may exist a charging mechanism such as a connector that allows the lights to plug into a charging base, a DC jack such that a wall transformer may be plugged into a normal AC outlet and into the DC jack to charge the unit or the light may contain a battery door allowing the rechargeable batteries to be removed, charged and replaced and the like.

[0323] In embodiments, it is to be appreciated that the wireless LED spotlight used to create the wireless track light may use RF or IR control, sensor control or any form of wireless control mentioned herein. By way of an example, the wireless track light with multiple RF controlled wireless spotlights may be controlled by a remote control RF transmitter. It is to be appreciated that the wireless LED spotlight may contain the intelligence necessary to implement the programmable functions for a wireless light module or apparatus mentioned herein. In some embodiments, the housing may not be similar to a spotlight but rather it may be similar to the ceiling light or any other form of housing for a wireless lighting module or apparatus mentioned herein. In some embodiments, there may be a rail or bar that mounts to the ceiling, wall or under cabinet and the wireless lights that make up the wireless track light attach to the rail or bar. In an alternate embodiment, the rail or bar may contain a wireless power source such as batteries such that the wireless lights are powered by that power source and may not contain a power source internally. In such a case, there may be electrical wiring from the power source within the rail or bar to the individual wireless lights. In an alternate embodiment, the rail or bar contains one or more connectors that the lights plug in to that provide a power source and control. In some embodiments, the rail or bar may also contain a wireless control source that is wired to the wireless lights or is available at the connectors the lights plug into such that a single point of wireless control may control all of the wireless lights used with the wireless track light. In the embodiment where there is a mounting mechanism to mount the spotlights to support bars of a drop ceiling, there may be wireless power or wireless control installed above the support bar (i.e. hidden from sight) and wired to the wireless lights via wires that enter the wireless light at the mounting mechanism above the support bars of the drop ceiling.

[0324] In embodiments of the ceiling light, there may exist in the ceiling light module a carbon monoxide, smoke detectors, heat detector, flame detector and/or thermal sensors in addition to any other form of wireless control or wireless power that may be present. In some embodiments there may be an indication of an alarm when the detector crosses some threshold. In such a case, the alarm may be audible through a bell, buzzer, horn, speaker etc. The ceiling light may also provide a visible indication of the alarm for example by blinking the light, illuminating a different color light source like a red LED or the like. In some embodiments, the ceiling light may contain a transmitter that may transmit a message to indicate an alarm and a disparate device may take action based on the alarm. By way of an example, the ceiling light may include a smoke detector that may transmit a message to a fire alarm system. In an alternate example, the ceiling lights may form a mesh network such that the detection of an alarm in one location may be propagated through the network such that other ceiling lights installed in the area may provide an

alarm indication even if they do not directly detect the alarm situation. In one use case of this example, a set of eight ceiling lights with one or more of the sensors mentioned herein work as a group such that when one ceiling light detects the alarm, all of the ceiling lights generate an alarm automatically. In this case, there may be no need for a central controller and the distributed intelligence in the ceiling lights provides a standalone safety system. In an alternate embodiment, the ceiling light may contain a motion sensor such that it may be able to transmit a message to a home alarm system to provide an indication of an intruder. There may also be a button on the ceiling lights that allow a user to push the button to test the one or more ceiling lights such that when the button is pushed, the alarm message is propagated through the network. In alternate embodiments the unit is in the form of a night light or sensor light that may be mounted anywhere, there may exist in the night light or sensor light module a carbon monoxide, smoke detectors, heat detector, flame detector and/or thermal sensors in addition to any other form of wireless control or wireless power that may be present and the indication of an alarm may be as mentioned herein. By way of an example, a motion sensor night light that is battery powered may operate under normal conditions as a night light that may be installed anywhere, however it may also contain a smoke detector such that when smoke is detected, an alarm indication of some type is asserted such as a buzzer to provide an audible indication of the alarm condition.

[0325] In another embodiment, a version of the wireless lighting module may target wireless LED spotlight applications where a UV or IR light source is present in the spotlight. When motion is detected, the LED spotlight turns on the UV or IR light source such that a detector (security camera etc) may be able to see the area illuminated by the UV or IR light without the light being visible to anyone or anything in the area. By way of an example, this application for safety and security may allow a user to see an intruder without the intruder knowing that they have been detected.

[0326] A number of methods have been mentioned herein by which a wireless light bulb or wireless lighting module may be programmed or configured for operation. The methods in embodiments of the programmable wireless light bulb or programmable wireless lighting module may include direct configuration or control of the unit through one or more buttons, dials, toggles, switches, levers, knobs, an LED touch screen, a keypad, or any such controls on the unit, configuration of the unit via the communication interface, configuration of the unit by design, configuration of the unit by factory pre-programming, configuration of the unit through processing the inputs and adjusting state appropriately, configuration of the unit through some sequence of action to indicated to the unit a configuration and the like. It is to be appreciated that any combination of programming or configuration method is possible in embodiments of a wireless light bulb or wireless lighting module.

[0327] In a direct configuration example, configuration and programming is controlled by the setting and use of one or more input devices accessible to the user on the unit itself. By way of an example, an AC powered wireless light bulb with a light sensor may have a dial on the unit that allows the user to set the net light level directly. To do this, the user may turn the light on in an environment with any amount of ambient light and turn the dial until the light intensity provided by the light plus the amount of ambient light is at a level desired by the user. Intelligence within the AC powered wireless light bulb

with light sensor will thereafter monitor the detected light level from the light sensor and adjust the light intensity output to match the user setting. In an alternate direct configuration example, an AC powered wireless light bulb in a PAR30 form factor the user may have access to a slide switch with multiple positions each position representing a light output level. Intelligence, electrical circuitry etc in the bulb may detect the switch position and adjust the light intensity level based on the switch setting. For example, the light output level of the bulb in one setting may be equivalent in light output to a typical 40 W incandescent light bulb, in a second switch setting it may be equivalent to a 60 W incandescent light bulb and in a third switch setting it may be equivalent to 75 W incandescent light bulb. Thus the user may have one PAR30 light bulb that, by changing the switch position on the bulb, have available to them three different light bulb types. In an alternate example, the slide switch is replaced by a dial and the user may turn the dial to a more exact brightness level. In this example, when the dial is turned to the lowest setting, the bulb may have a light output equivalent to a typical 20W incandescent light bulb and when the dial is turned to the highest setting, the bulb may have a light output equivalent to a typical 75 W incandescent bulb. Thus, the light output may be adjusted using the dial from equivalent to a 20W incandescent bulb to the equivalent of a 75 W incandescent bulb. This function may be used a dimmer switch for bulbs that are used in applications where the bulb is within reach of the user, for example a desk lamp, a reading lamp, an interior automotive lamp etc where the dimmer switch is in effect located on the bulb itself.

[0328] In a configuration of the unit via the communication interface example, a wired or wireless connection to the unit may allow a user to configure or program a wireless light bulb or wireless lighting module by sending and receiving messages over the communication interface to program any functionality mentioned herein. It is to be appreciated that the wireless light bulb or wireless lighting module may contain volatile and/or non-volatile memory to store the configuration or program information. In the example of the light bulb that may be set to a 40W, 60W or 75 W incandescent bulb equivalent, a command may be sent to the bulb over a communication interface to select the light intensity level for operation. In another example, the unit has a connector on the unit that a user may plug a cable with the other end plugged into some type of programming apparatus (computer, handheld etc.) such that a user may configure or program the unit using the programming apparatus. In a configuration of the unit by design or by configuration of the unit by factory pre-programming example, a wireless light bulb or wireless lighting module may have a level preset such that the user may expect the functionality to operate as such. For example, there may be a single auto-shutoff timer in a motion sensor controlled product where the auto-shutoff time is set in the design or pre-programmed at the factory based on a customer order. In an alternate example, a daylight harvesting wireless light bulb is preset such that the output light intensity plus the measurement of the ambient light level is maintained at a constant light level. In this case, a daylight harvesting bulb that maintains the equivalent ambient light level as a 60W incandescent bulb by setting its output light intensity to meet the preprogrammed light detection level equivalent to the 60W incandescent bulb.

[0329] In a configuration of the unit through processing the inputs and adjusting state appropriately or configuration of

the unit through some sequence of action to indicate to the unit a configuration, the unit may learn its configuration and in effect program itself for operation. For example, a motion sensor controlled wireless light bulb or wireless lighting module that also contains a time of day clock may detect a lot of motion at certain times of the day. If the motion statistics exceed a certain level, the unit may program itself to turn on automatically at that time of day just prior to when the detections would indicate the expected motion. In an alternate example, power sequencing may be used to configure the operation of a wireless light bulb. If the power is sequenced on, then off, then on again in durations of time understood by the wireless light bulb, the bulb may be configured for a specific operation. For example, if a motion controlled wireless light bulb is turned on and left on, the motion sensor may be disabled. If the power is sequenced in the manner described, the motion sensor may be enabled and controls the wireless light bulb until power is turned off.

[0330] In an embodiment, a wireless AC outlet may be designed with batteries embedded to provide power to any kind of electrical device that plugs into the outlet. The adapter may contain an integrated wireless power source (batteries for example), a DC/AC inverter and control that is either wireless control or manual control such as a switch on the wireless AC outlet that may turn it on or off. The user may then plug in AC powered devices to the wireless AC outlet to power that device. By way of an example, a wireless AC outlet may be mounted to a wall in any location the user desires or it may be mounted to a post that may be driven into the ground. It is to be appreciated that the wireless AC outlet may be designed in any housing and contain any mounting mechanism as required by a particular application. It is to be appreciated that the power supplied by the wireless AC outlet may be limited to the energy delivery capacity of the integrated power source. By way of an example, a wireless AC outlet with a single AC socket and 4 C alkaline batteries may be limited to the power that the C batteries may be able to provide to an AC powered device. In embodiments that are powered by batteries, the wireless AC outlet may contain a battery door that allows the batteries to be removed and replaced with fresh batteries. In an alternate embodiment, the wireless AC outlet may contain rechargeable batteries and a method to charge the batteries. The wireless AC outlet may contain a connector that allows it to plug into a charging base, it may contain a DC jack such that a wall transformer may be plugged into a normal AC outlet and into the DC jack on the wireless AC outlet, it may contain a battery door allowing the rechargeable batteries to be removed, charged and replaced and the like. In alternate embodiments, the wireless AC outlet may contain an energy harvesting wireless power source and integrated rechargeable batteries such that the energy harvesting source may provide power to the wireless AC outlet and/or charge the batteries as necessary. By way of an example, a wireless AC outlet contains solar cells and an electrical circuit necessary to take the energy received from the solar cells and provide power for the wireless AC outlet, charge the batteries and/or share the load between the solar cells and batteries.

[0331] In embodiments containing a grid tie inverter, the capability for a user to explicitly command a return of power to the grid may exist. For example, a user may have a control mechanism that may detect the battery charge levels in a device containing a grid tie inverter and if the user desires to return power to the grid the ability to command such a return

exists. It may exist through software control or the like, but it may also exist through direct control on the device itself. In some embodiments, the user may have the ability to command the return of power to the grid based on battery capacity level such that there will be some reserve energy storage if needed. The user may set an upper threshold of battery capacity level to begin the return of power to the grid and a lower threshold of battery capacity level where the return of power to the grid may stop to maintain a reserve energy storage level or to prevent over discharge of the battery to optimize rechargeable battery life. Thus the user may be able to control the return of energy to the grid such that there is not a situation when a battery is fully charged when it is advantageous to be charging the battery (for example some time prior to off peak hours when the battery may start charging again). In alternate embodiments, the explicit command to return energy to the grid may come from the power company, from a smart meter, from a remote connection where the user may access such controls over the Internet and so on.

[0332] In an embodiment of a wireless lighting apparatus, a book light consisting of a book with circuitry embedded, integrated power source such as a battery, switch and one or more LEDs may be designed such that when a reader opens the book, a switch opens or closes with the opening the book and the LED is illuminated. When the book is closed, the LED is turned off. In some embodiments, there may be another switch to enable or disable the LED light if the user desires. In some embodiments, the one or more LEDs may be attached to an arm that elevates as the book opens. In this case, the one or more LEDs may be directed in a way that they would point toward the area where the illumination is needed. By way of an example, the book light may be used in a restaurant check book such that when a diner opens the book to view their check, the LED illuminates the check area. When they close the check book, the LED shuts off. In this example, the check book light consists of a coin cell battery, a push button that disables the light by pressing the button while the check book is closed and an LED to illuminate the check book when open.

[0333] In an embodiment, an AC outlet adapter may be designed with batteries embedded to provide power to an alarm clock when there is a power outage. By way of an example, the adapter may plug into an AC wall outlet and also have an AC socket that the alarm clock plugs into. In an alternate embodiment, the AC outlet adapter that the alarm clock plugs into provides backup power for the alarm clock but also contains an LED reading light that is powered by the AC outlet adapter. The LED reading light may be attached to a flexible arm such that the user may be able to articulate the light in the direction needed to provide illumination as necessary. There may be a control mechanism, such as an on/off switch, at any point on the LED reading light such that the user may turn the LED reading light on or off as desired without affecting the battery backup for the alarm clock.

[0334] In embodiments of the wireless light bulb or wireless lighting module where one communication interface is WIFI, the wireless light bulb or wireless lighting module may also be able to act as a WIFI repeater device. In such a case, the wireless light bulb or wireless lighting module is capable of operating on a single channel and receive then transmit packets on WIFI. In alternate embodiments, the wireless light bulb or wireless lighting module may operate on multiple WIFI channels such that the unit may be able to receive traffic on one channel and transmit that traffic on a different channel.

It is to be appreciated that as a WIFI repeater, the wireless light bulb or wireless lighting module operate on any number of channels as required.

[0335] In embodiments of the wireless light bulb or wireless lighting module, the light source may be LED, compact fluorescent, fluorescent, induction, halogen, gas discharge, organic LED (OLED), plasma, radio generated plasma or incandescent. In one example, a wireless light bulb may be designed with one or more OLED panels as the light source. The OLED wireless light bulb may be designed in any type of housing mentioned for a wireless light bulb. In one example, the OLED wireless light bulb is designed to mount to a ceiling or replace a ceiling panel. The OLED wireless light bulb may contain any form of wireless control, power source and/or intelligence control typical of a wireless light bulb. In another example, wireless light bulb may be designed with a radio generated plasma light source. The radio generated plasma wireless light bulb may be designed in any type of housing mentioned for a wireless light bulb. In one example, the radio generated plasma wireless light bulb is designed in an A19 bulb housing. The radio generated plasma wireless light bulb may contain any form of wireless control, power source and/or intelligence control typical of a wireless light bulb.

[0336] The previously mentioned wireless lighting modules can be grouped into kits to meet specific user applications. A residential or commercial power saver kit can be constructed of any mix of wireless lighting module light bulbs in a kit to allow installation in a residential or commercial building for savings on energy bills. For example, a home power saver kit that includes ten AC powered, battery backed wireless lighting module light bulbs can be used by a consumer to replace the R30 incandescent bulbs in their house that would typically be used in recessed lighting fixtures at substantial savings on power consumption.

[0337] A residential or commercial emergency lighting kit can be constructed of any mix of wireless lighting module light bulbs in a kit to allow installation in a residential or commercial building for switching over automatically to battery backup when an AC power outage is detected. For example, an emergency lighting kit that includes twenty AC powered, battery backed wireless lighting module light bulbs can be used by a consumer to replace the R30 incandescent bulbs in their house that would typically be used in recessed lighting fixtures at substantial savings on power consumption.

[0338] In embodiments of wireless light bulbs or battery powered wireless lighting fixtures containing a PIR device for motion sensing, a thermal sensor may be present to provide a measurement of temperature to allow temperature compensation of the threshold for motion detection. In some embodiments, a temperature dependant voltage may be generated using a thermistor, a resistor network and a supply voltage where the output voltage is dependent on the resistance of the thermistor and that output voltage may be used to derive the threshold voltage used for motion detection. Thus, the change in sensitivity of the motion sensor over temperature may be compensated for by changing the threshold of the motion detection circuit. By way of an example, an operational amplifier used as a comparator at the output of the motion sensing circuitry has a threshold that the voltage that is a representation of the detected motion is compared against. Over temperature, the amplified output of the PIR sensor may vary to the point that false triggers may occur which would turn the light on when motion is not detected or has not been

detected sufficiently to turn the light on. If the threshold at the comparator varies with temperature, the threshold may move higher or lower compensating for the changes in performance of the PIR sensor and motion detector circuitry. In an alternate embodiment, the temperature is measured, converted from analog to digital, read by a microcontroller and the microcontroller may set a threshold value through a digital to analog conversion based on the temperature reading. In such a case, to determine the proper threshold level the microcontroller may have an algorithm programmed in it to calculate the required threshold based on the measured temperature, the microcontroller may contain a lookup table such that stored in memory a lookup using the read temperature will return the required threshold value and the like. In another embodiment, the wireless light bulb or battery powered wireless lighting fixture may have a communication interface such that a processor that has a measurement of temperature may send a command to the bulb or fixture to set the motion detection threshold for compensation. It is to be appreciated that any method of measuring temperature and using that information to modify the threshold based on the input temperature may be used.

[0339] In embodiments of wireless light bulbs or battery powered wireless lighting fixtures containing any type of sensor, power circuitry, LED driver circuit or LED device that may change performance over temperature, a thermal sensor may be present to provide a measurement of temperature to allow the behavior of the sensor, power circuitry, LED driver circuitry or LED device to be adjusted over temperature. The adjustment based on detected temperature may be measured using any type of temperature measuring mechanism mentioned herein. An electrical circuit, microcontroller, microprocessor, ASIC etc may be present to process the measured temperature make an adjustment based on the measurement. By way of an example, one or more thermal sensors may be connected to the heatsink which the one or more LED devices are attached to. A measurement of the heatsink temperature may be used to adjust the LED driver circuit current to a lower or higher drive level based on the temperature reading. For example, if there is a maximum heatsink temperature allowable, when the detected temperature is read at or close to that level, an electrical circuit, microcontroller, microprocessor, ASIC etc may reduce the drive current such that there is less heat generated by the LEDs and subsequently the temperature will remain the same or start to lower due to the change in drive current. It is to be appreciated that the drive current may be adjusted based on the temperature measurement of any one or more components of a wireless light bulb or battery powered wireless lighting fixture or a measurement of the ambient temperature inside or outside of the wireless light bulb or battery powered wireless lighting fixture. By way of another example, a light sensor may be used for daylight harvesting such that the detected value of the ambient light level may be used to set the light intensity of the light source such that the total light maintains some constant level. A thermal sensor may be used for compensation of the light sensor over temperature such that the ambient light measurement is adjusted over temperature. For example, a microcontroller may read a voltage level at the output of a light sensor circuit through an analog to digital converter. The microcontroller may also read a temperature dependant voltage that is generated using a thermistor, a resistor network and a supply voltage. The microcontroller may control the light intensity of the light source based on the reading of the ambient light level adjusted

based on the temperature measurement. In another example, the measured temperature may be used to change the gain of a receiver circuit for better operation over the operating temperature range. It is to be appreciated that the measured temperature may be used to adjust any sensor, power circuitry, LED driver circuit or LED device with preset temperature curves that determine a lookup table to provide the adjustment, an algorithm to derive the adjustment to be done based on temperature and/or time, an automatic adjustment done by an electrical circuit designed to make the adjust based on the temperature reading, an adjustment received over a communication interface and the like.

[0340] In one embodiment, an AC powered battery embedded motion wireless light bulb contains rechargeable batteries and a PIR motion sensor. In some embodiments, there may be a light sensor inside the bulb to enable the motion sensor for operation or to be used for daylight harvesting. A charging circuit that supports recharging the batteries in circuit may be inside the bulb. There may be circuitry to allow either power source to be used independently or to share the load depending on whether each power source is present and able to supply power to the wireless light bulb. An electrical circuit, microcontroller, microprocessor, ASIC etc may be present to perform the selection of which power source to use. The selection of which power source to use may be programming into the wireless light bulb through preprogramming at the factory or the like, through a programming method over a communication interface that may be present in the bulb or it may be set directly on the unit through a method of control such as a dial, push buttons, slide switches and the like where a user may set whether to use the AC power source, the battery power source or a sharing of the load between AC and battery power, to enable or disable the motion sensor, to set the auto-shutoff time period, to set the light intensity level in a mode of operation or to enable or disable the light sensor. In some embodiments, there may be a time of day clock or timer present to control state changes or change the configuration based on time of day. By way of an example, the AC powered battery embedded motion wireless light bulb may be enabled during daytime hours to be controlled by the AC wall switch where the unit is AC powered. During evening hours or during a detected power outage, the AC powered battery embedded motion wireless light bulb is powered by battery power and is controlled by the motion sensor to turn the light source on and off. In some embodiments, the AC powered battery embedded motion wireless light bulb may include a fade-to-off effect, fade-to-dim effect, fade-to-glow effect, fade from one light intensity level to another light intensity level and so on. In some embodiments, the AC powered battery embedded motion wireless light bulb may include an increase in light intensity over time which may include an off-to-glow effect, glow-to-dim, glow-to-some light intensity level, an increase from one light intensity level to a higher light intensity level and so on. It is to be appreciated that the change from one light intensity level to another light intensity level may happen over any period of time that may be implemented with the timers. In some embodiments, the AC powered battery embedded motion wireless light bulb may include a daylight harvesting function which allows for the light intensity level of the light source to be set based on the detected ambient light level.

[0341] In some embodiments, the AC powered battery embedded motion wireless light bulb may sense the state of one or more switches or breakers in the controlling circuit and

switch over to battery power if the detected switch state indicates that the AC power should be present, but AC power is not present. The device may also measure the impedance, resistance, and/or capacitance across the AC power input and return or may measure any other electrical characteristic of the AC power input and return to determine whether the controlling switch or breaker is open or closed (or if electricity has been turned off at any point up to the AC input of the device). By way of an example, if the controlling switch or breaker is open, there may be a high impedance detected across the input AC power and return. If the controlling switch or breaker is closed, there may be a measureable impedance, resistance and/or capacitance or electrical characteristic different from when the controlling switch or breaker is open. A threshold may be set in the device such that if the measurement is above or below the threshold, the switch or breaker is closed, and if the measurement is on the opposite side of the threshold, the switch or breaker is open. The device may be controlled by the state of the controlling switch or breaker (on or off), but may also detect the condition when the controlling switch or breaker is closed but AC input power is not present or is not acceptable and may be able to switch over to the rechargeable or non-rechargeable batteries that are embedded as the power source. In some embodiments, the AC powered battery embedded motion wireless light bulb may perform an impedance discontinuity check to determine if the controlling switch or breaker is open or closed. In some embodiments, the AC powered battery embedded motion wireless light bulb may generate a signal onto the line and monitor the electrical response of the line to determine if the response indicates an open circuit that may be indicative of a switch or breaker open in the lighting circuit. It is to be appreciated that when the switch sense functionality is implemented, the switch or breaker may still be able to turn on and off power to the AC powered battery embedded motion wireless light bulb even when running off of the embedded battery power source because the AC powered battery embedded motion wireless light bulb may be able to determine if the switch is on or off and apply power or not apply power to the AC powered battery embedded motion wireless light bulb based on the switch position. In such a case, the switch sense circuitry may still need to be powered along with any other necessary circuitry to implement this function even when the AC powered battery embedded motion wireless light bulb is not being powered.

[0342] In embodiments of wireless light bulbs or battery powered wireless lighting fixtures containing a motion sensing capability, there may be a number of methods by which motion is detected. There may be a radar based motion sensor where a transmitter exists in the wireless light bulb or battery powered wireless lighting fixture to transmit pulses of radio frequency or microwave. The wireless light bulb or battery powered wireless lighting fixture may contain a receiver to receive the reflected waves allowing it to determine if there is an object in range, how far away the object is, the velocity of the object and other characteristics of the object. Thus, using a radar based motion sensor may allow detection of an object in the detection area, not just that the object is moving. A radar based motion sensor may provide information about the range to the object which may allow for intelligent decisions to be made about whether the object that is detected should trigger a change of state of the wireless light bulb or battery powered wireless lighting fixture. By way of an example, a wireless light bulb may turn on only when an object is within

20 feet of the wireless light bulb. A radar based motion sensor may determine that an object is 30 feet away and thereby, even though the object is detected, still not turn the light on or turn the light on to a lower light intensity until the object moves within 20 feet. It is to be appreciated that the transmitter may be disparate meaning that the transmitter may not be built into the bulb or fixture but rather may be a separate standalone unit where a receiver in the bulb or fixture may receive the transmitted pulses and reflections of the transmitted pulses that were generated by the disparate transmitter device and react based on the reception without having to have transmitted the pulses. It is to be appreciated that a radar wireless light bulb or battery powered wireless lighting fixture may operate in any radio band with any form of modulation where a radar based motion sensor may be operate.

[0343] In other embodiments of wireless light bulbs or battery powered wireless lighting fixtures containing a motion sensing capability, there may be a sonar based motion sensor where sound propagation is used by the wireless light bulb or battery powered wireless lighting fixture to detect objects in the field of view. An acoustic transmitter that may transmit any frequency acoustic wave creates the wave and a receiver listens for the echo return of the transmission. Intelligence in the wireless light bulb or battery powered wireless lighting fixture may analyze the received signal and determine if an object is in the field of view and the distance to that object. Thus, using a sonar based motion sensor may allow detection of an object in the detection area, not just that the object is moving. A sonar based motion sensor may provide information about the range to the object which may allow for intelligent decisions to be made out whether the object that is detected should trigger a change of state of the wireless light bulb or battery powered wireless lighting fixture. It is to be appreciated that the acoustic transmitter may be disparate meaning that the transmitter may not be built into the bulb or fixture but rather may be a separate standalone unit where a receiver in the bulb or fixture may receive the echo return of the transmissions that were generated by the disparate transmitter device and react based on the reception without having to have transmitted the pulses.

[0344] In some embodiments of wireless light bulbs or battery powered wireless lighting fixtures there may be a disparate magnetic switch and an RF or IR transmitter that detects when the magnetic switch is open, closed or has just changed state and may transmit the state information to a wireless light bulb or battery powered wireless lighting fixture containing a receiver. Thus, a magnetic switch sensor may be placed anywhere (where the magnet and magnetic switch may be separate housings) to detect a make or break of the magnet and magnetic switch. By way of an example, the magnetic switch may be attached to a door or window frame and the magnet may be attached to the door or window. When the door or window is closed, the magnetic switch may be actuated. When the door or window is opened, the magnetic switch changes state and the disparate magnetic switch and transmitter transmits the change of state information to one or more wireless light bulbs or battery powered fixtures that may be controlled by the disparate sensor. It is to be appreciated that the magnetic switch and magnet may be attached to any two items that a user may desire a separation of the two items to change the state of one or more wireless light bulbs or battery powered lighting fixtures. In alternate embodiments the magnetic switch is not a disparate device but rather is located in or on the housing of the wireless light bulb or

battery powered wireless lighting fixture and the magnet is external to the housing such that the wireless light bulb or battery powered fixture receives a direct indication of the state or change in state of the magnetic switch with respect to the magnet.

[0345] In some embodiments of wireless light bulbs or battery powered wireless lighting fixtures there may be a disparate pressure switch and an RF or IR transmitter that detects when the pressure switch is open, closed or has just changed state and may transmit the state information to a wireless light bulb or battery powered wireless lighting fixture containing a receiver. Thus, a pressure switch sensor may be placed anywhere to detect when an actuating force is applied to the switch. By way of an example, a pressure switch may be embedded in flooring such that when an object is detected on the flooring, for example a person walking across the floor, the pressure switch changes state and transmits the state information to one or more wireless light bulbs or battery powered wireless lighting fixtures that may be controlled by the disparate sensor. It is to be appreciated that the pressure switch may be attached to any item that a user may desire a detection of pressure applied to the item to control the state of one or more wireless light bulbs or battery powered lighting fixtures. In alternate embodiments the pressure switch is not a disparate device but rather is located in or on the housing of the wireless light bulb or battery powered fixture such that the wireless light bulb or battery powered fixture receives a direct indication of the state or change in state of the pressure switch. In alternate embodiments, more than one pressure switch is monitored and the result of a state change of any of the pressure switches may be transmitted by the RF or IR transmitter. By way of an example, a large mat of pressure switches may be installed under carpeting such that any pressure switch change of state may be transmitted to the wireless light bulb or battery powered wireless lighting fixture. This way the pressure switches may cover an area and it would be less likely that someone or something may pass the pressure switch mat without being detected.

[0346] In some embodiments of wireless light bulbs or battery powered wireless lighting fixtures there may be a disparate infrared beam or laser beam created by a transmitter and receiver and an RF or IR transmitter that detects when the infrared beam or laser beam between the infrared or laser transmitter and receiver is present or broken or has just changed state and may transmit the state information to a wireless light bulb or battery powered wireless lighting fixture containing a receiver. Thus, an infrared beam or laser beam break may be detected by placing the infrared or laser transmitter and separate receiver anywhere. By way of an example, an infrared transmitter and receiver may be installed at the end of a driveway such that when an automobile drives into the driveway, it breaks the infrared transmission that is detected by the receiver. The infrared beam changes state due to the beam break and the infrared receiver device transmits the state information to one or more wireless light bulbs or battery powered wireless lighting fixtures that may be controlled by the disparate infrared beam break. It is to be appreciated that the infrared or laser transmitter and receiver may be attached to any two items that a user may desire a detection of an object between the infrared or laser transmitter or receiver to control the state of one or more wireless light bulbs or battery powered lighting fixtures. In alternate embodiments the infrared receiver is not a disparate device but rather is located in or on the housing of the wireless light bulb or

battery powered fixture such that the wireless light bulb or battery powered wireless lighting fixture receives a direct indication of the state or change in state of the infrared or laser transmitter and receiver beam break.

[0347] In embodiments of wireless light bulbs or battery powered wireless lighting fixtures containing a motion sensing capability, there may be a number of mechanisms to control how the motion sensing is used to control the wireless light bulb or battery powered wireless lighting fixtures. In some embodiments, the motion sensor may be enabled or disabled through the use of a time of day or timer control such that the motion sensor will be enabled or disabled based on a time setting that is programmed into the bulb or fixture. In some embodiments, there may be an external control mechanism that allows a user to enable or disable the motion sensor. By way of an example, a motion sensor wireless light bulb may be controlled by a wall switch that has an additional switch on it allowing a user to enable or disable the motion sensor (i.e. override the motion sensor) such that the primary control mechanism will be the wall switch or some other mechanism when the switch is in one position and the primary control mechanism will be the motion sensor when the switch is in the other position. By way of another example, there may be an RF or IR receiver in the wireless light bulb or battery powered wireless lighting fixture that would allow a user to enable or disable motion sensor control using a remote control that may transmit the control to the bulb or fixture. The remote control may have controls such as pushbuttons, switches, dials etc that enables, disables or changes the sensitivity of the motion sensor control. The remote control may set time of day or timer control of when the motion sensor control is active. A light sensor may be used to enable or disable the motion sensor. The light sensor may be used to disable the motion sensor during the daytime when the amount of ambient light that is detected is above a threshold. The light sensor may be used to determine which other control mechanisms may be used instead of motion sensing. By way of an example, in an embodiment of the wireless light bulb, the light sensor may enable motion detection during the night, but during the daytime the wall switch will control power to the wireless light bulb.

[0348] In embodiments of wireless light bulbs or battery powered wireless lighting fixtures containing a motion sensing capability, there may be an ability to change the field of view of the motion sensor by positioning the motion sensor to change the field of view. By way of an example, a wireless light bulb or battery powered wireless lighting fixture may contain a PIR sensor that is mounted to a mechanical apparatus that may allow for “telescoping” the sensor such that it may be pointed in any direction required for motion detection. In an alternate embodiment, a radar or sonar transmitter and/or receiver may be capable of pointing in any direction required for a field of view where motion is to be detected. Thus, the capability to telescope or point the motion sensor in any direction allows the motion sensor to be placed in the optimal position for motion detection.

[0349] In some embodiments of wireless light bulbs or battery powered wireless lighting fixtures there may be an ability to detect sound or spoken commands and change the state of the bulb or fixture based on the sound or spoken commands. By way of an example, a wireless light bulb or battery powered wireless lighting fixture may contain a microphone and the intelligence to process speech such that if a user speaks commands such as “Bulbs on”, “Bulbs off”,

“Dim up”, “Dim down” or the like the bulb or fixture may change state based on the command detected by speech.

[0350] In an embodiment of a wireless light bulb powered from only AC power or powered only by battery power or in embodiments of a battery powered wireless lighting fixtures, the wireless light bulb or battery powered wireless lighting fixture may contain intelligence to control the light source based on time of day and may be programmed by controls on the housing of the bulb or fixture. Those controls may be in the form of pushbuttons, switches, dials etc. By way of an example, the time of day wireless light bulb or battery powered wireless lighting fixture may contain ON, OFF and PROGRAM pushbuttons. At the specific time of day that the user desires the bulb or fixture to automatically turn on, the user presses the ON and PROGRAM buttons simultaneously. A microcontroller, microprocessor, ASIC etc may contain a time source, such as a real time clock, free running timer or the like, and may contain the intelligence to record that time and a state change based on that time such that every day at that time or on regular intervals of the free running timer, the time of day wireless light bulb or battery powered wireless lighting fixture will automatically turn on. At another specific time during the day that the user desires the bulb or fixture to turn off, the user presses the OFF and PROGRAM buttons simultaneously. In alternate embodiments, there may be controls to set the light intensity of the bulb or fixture. In such embodiments, there may be a DIM UP and DIM DOWN pushbutton, dial switch or the like control and a method to use the PROGRAM button or similar to record the change in light intensity at that time. By way of an example, the user may desire to reduce the light intensity during the day due to the higher ambient light levels and therefore may use the DIM DOWN control to set the new light intensity level first thing in the morning, then use the PROGRAM button in some manner to program that light intensity level change at that time of the day every day. The user may then set a higher intensity level at night time by using the DIM UP control to increase the light intensity level and then use the PROGRAM button to program that light intensity level at that time every day. There may be a CLEAR control mechanism that may allow a user to clear programmed state changes. It is to be appreciated that the user may program as many on, off and light intensity setting at different times of day as may be programmed into the device. Programming by time of day may provide some cost savings in energy usage when lighting needs to be on most or all of the day. It is to be appreciated that there may be any number of changes in the light output and the light intensity may be set to any level from off to maximum light intensity. In alternate embodiments, the same control may be provided by a communication interface in the bulb or fixture such that similar ON, OFF, DIM UP, DIM DOWN, PROGRAM and the like controls are on a remote control. The external device communicating with and controlling or programming the bulb or fixture may be a computer running a software program, a custom remote control, a building management unit, a lighting circuit control unit etc. and may have the communication interface allowing it to communicate with the bulb or fixture. It is to be appreciated that settings programmed in the bulb or fixture may be stored in non-volatile memory such that when the device is powered down, the programming is not lost. It is to be appreciated that there may be an integrated power source that may allow the real time clock or timers to continue running when power to a wireless light bulb is turned off. In embodiments that are only powered

by battery power, the intelligence may also use battery capacity level to set the light intensity output. In such an example, battery power may be rechargeable or non-rechargeable batteries or fuel cells. It is to be appreciated that any wireless power source or any combination of wireless power sources may be used to supply power to or recharge energy storage in the bulb or fixture in connection with the battery powered bulb or fixture controlled based on time of day.

[0351] In an embodiment of the UPS light bulb, the UPS light bulb is not in a typical housing such as a standard size bulb, non-standard size bulb, fixture, fluorescent bulb, fluorescent lamp or down light assembly, but is rather an adapter that plugs into an existing fixture that a standard size bulb, non-standard size bulb, fluorescent bulb or lamp would plug into such that this UPS light bulb adapter may provide all of the functionality of the UPS light bulb including a light source in the UPS light bulb adapter in addition to the off the shelf bulbs or lamps plugged into it. By way of an example, the UPS light bulb adapter has a light source in the adapter. The UPS light bulb adapter typically will pass power through to the bulb or lamp plugged into it such that the bulb or lamp may be the light source. When the UPS light bulb adapter detects that power has dropped out (i.e. there is a power outage) or some other characteristic that makes power no longer desirable to use (brownout conditions, electrical surges, overvoltage conditions, voltage sag or flickers, line noise, frequency variations, switching transients, harmonic distortion, etc.), the adapter may turn on its embedded light source powered by the power source integrated into the UPS light bulb adapter. Thus, a UPS light bulb adapter may typically consist of a connector allowing it to plug into a socket, a socket connector allowing a bulb or lamp to plug into it, a housing allowing it to fit into the fixture where it will be installed, a light source, an integrated power source and charging circuitry if needed, power circuitry such as an AC/DC converter, input from a ballast controller or the like, circuitry to monitor the power input and any wireless control that may be used to control the UPS light bulb adapter such as a receiver allowing a remote transmitter to control the UPS light bulb adapter. It is to be appreciated that the light source may be located in a manner to direct light out of an existing fixture to provide light coming out of the existing fixture with the bulb or lamp plugged into it. For example, if a PAR30 light bulb plugs into the UPS light bulb adapter in a fixture and the UPS light bulb adapter contains an LED light source, the one or more LEDs may be mounted on UPS light bulb adapter housing such that the light emitted from the one or more LEDs is pointed to the outer edge of the PAR30 light bulb. When the LED light source of the UPS light bulb adapter is turned on, the light emitted by the LED light source will be from behind the PAR30 light bulb, but will be directed toward the opening between the edge of the PAR30 light bulb and the fixture such that the PAR30 light bulb would obstruct as little of the light as possible. By way of an example, in a six inch recessed fixture, the UPS light bulb adapter is plugged into the Edison socket. An R30 bulb is plugged into the UPS light bulb adapter. The UPS light bulb adapter may switch on the backup light source and integrated power source for any reason. For example, the UPS light bulb adapter may have the circuitry present to monitor the input AC power at the Edison socket. If the UPS light bulb adapter detects that power is not present at the Edison socket, the light source may be turned on. The UPS light bulb adapter may contain a relay or switching circuit such that power to the bulb or lamp plugged in may be opened

by the UPS light bulb adapter whether power is present or not. In such a case, the UPS light bulb adapter may make intelligent decisions based on programming, wireless control or sensors on the adapter to switch to the backup light source or a user may explicitly switch over to the backup light source. The UPS light bulb adapter may contain the circuitry to sense the state of the one or more controlling switches or breakers in the lighting circuit in any manner mentioned here in (measuring the impedance, resistance, and/or capacitance at the AC power input, testing for an impedance discontinuity in the path to the AC input etc).

[0352] In one use case of an emergency lighting system, the lighting consists of wireless light bulbs or battery powered wireless lighting fixtures that are off grid and may receive transmission from a power outage module or an emergency lighting power outage module such that a detected condition that would require a switchover to emergency lighting, such as a power outage, would trigger a transmission to a detached emergency lighting system consisting of wireless light bulbs or battery powered wireless lighting fixtures containing one or more wireless power sources. They may have a connection to grid power, but typically the detached emergency lighting system will be entirely off grid. The wireless light bulbs or battery powered wireless lighting fixtures may have one or more forms of wireless control. The bulbs or fixtures may have a transceiver that would allow them to wirelessly communicate with one or more disparate wireless light bulbs and battery powered wireless lighting fixtures to enable coordinated operation between more than one bulb and/or fixture. Following this example, an input can be retransmitted within a network of wireless light bulbs and battery powered wireless lighting fixtures, where the network of lighting modules can be dispersed within a geographic area to create a detached emergency lighting system over a large area. By way of an example, an outdoor emergency lighting system may be created that is detached by using battery powered wireless lighting fixtures and a power outage module. Because the battery powered wireless lighting fixtures may be installed anywhere, a user may install them where there are no on grid power connections and still get lighting in an emergency situation. The battery powered wireless lighting fixtures may come in the form of stair lights, spotlights, path lights, exit signs and lighting, stair well lights, floor lights, ceiling lights, hallway lights, sconces etc to provide lighting in an emergency situation. If all of the battery powered wireless lighting fixtures are within range, the power outage module may directly turn them on during an emergency situation. If all of the battery powered wireless lighting fixtures are not in range, a network may be formed to propagate the emergency lighting commands to all of the lights in the detached emergency lighting system.

[0353] In some embodiments, a wireless light bulb or battery powered wireless lighting fixture may be built into an explosion proof or flame proof housing. The wireless light bulbs or battery powered wireless lighting fixtures may have a connection to on grid power and also have an integrated power source such as rechargeable batteries. In an emergency situation, such as an explosion or a fire in an industrial environment, the wireless light bulb or battery powered wireless lighting fixture may switch over to the integrated power source to continue to provide lighting after the emergency situation for an extended period of time. It is to be appreciated that there may be one or more lenses, reflectors, optical filters, aperture, and so on that are integrated into the housing of the

explosion or flame proof wireless light such that the light source may be protected from the cause of the hazard.

[0354] In some embodiments, a wireless light bulb or a battery powered wireless lighting fixture used may have an indication of a low battery level. There may be a method to test the bulb or fixture, such as a button that may be pressed to briefly test that the light output powered by an integrated power source is healthy, that may provide an indication of the battery level. In alternate embodiments, the wireless light bulb or battery powered wireless lighting fixture may have a transmitter designed in that may transmit a representation of the battery charge level to allow an external system such as a computer, laptop, handheld computer, dedicated hardware etc. to provide a user with a status on whether the battery power is at an acceptable level. By way of an example, in an emergency lighting system, a battery powered wireless lighting fixture may transmit its battery charge level to a central controlling station that would then provide an alarm to a user when the battery charge level is below a threshold. The user may then replace the batteries. In alternate embodiments, there is one or more colored LEDs or a multicolor LED on the wireless light bulb or wireless lighting module that may provide a visual indication of the battery charge level.

[0355] In some embodiments of wireless light bulbs and battery powered wireless lighting fixtures there may be a receiver that may receive an emergency broadcast such as a radio broadcast of the emergency broadcast system. In such embodiments, the bulbs or fixtures that detect the broadcast switch over to a mode to indicate to the users that there is an emergency situation such as blinking the lights. In alternate embodiments, the bulbs or fixtures may receive a local broadcast that a user may make to provide a visual indication provided by the lighting of an event. For example, a user may blink the lights three times to indicate that it is the end of break time and that workers on a break need to return to their stations. In another example, a school may blink lights some number of times in certain areas to indicate that the end of a period or session. In another example, an office building may blink some number of lights continuously to indicate an emergency situation. It is to be appreciated that wireless light bulbs or battery powered wireless lighting fixtures may receive a command and control the light output, color and intensity in any way possible to communicate a message to an audience. Any type of remote control can wirelessly communicate with the wireless light bulbs or battery powered wireless lighting fixtures to control or program this functionality into them. For instance, the remote control can be a stand-alone remote control and/or incorporated into a disparate device (e.g., incorporated into a key fob, a programmable wireless transceiver integrated in an automobile.). Moreover, the remote control can be a personal computer, a cellular phone, a smart phone, a laptop, a handheld communication device, a handheld computing device, a global positioning system, a personal digital assistant (PDA), and/or any other suitable device.

[0356] In some embodiments of an emergency lighting system, there may be a UPS light bulb, wireless light bulb or battery powered wireless lighting fixture with a receiver and a remote light sensor transmitter. The remote light sensor transmitter may be configured to detect the level of light and transmit to the UPS light bulb, wireless light bulb or battery powered wireless lighting fixture to turn them on or off. A user may install one or more bulbs or fixtures and place the remote light sensor transmitter in a location where the user

knows it should detect a high amount of ambient light. If the remote light sensor transmitter is no longer detecting light, it may mean there is a power outage and the lighting is disabled. The remote light sensor transmitter would then transmit to the UPS light bulb, wireless light bulb or battery powered wireless lighting fixture a command to change state such as switch to back up power, turn on, change the light intensity etc. It is to be appreciated that the remote light sensor transmitter may be detecting lighting that is not a UPS light bulb, wireless light bulb or battery powered wireless lighting fixture. In such a case, the remote light sensor transmitter may be used to switch to an alternate light source for example for the purpose of emergency lighting. In other embodiments, the light sensor is built into the UPS light bulb or wireless light bulb and detects when the lights go off due to a power outage or other reason. In such a case, the light sensor is powered by the integrated power source. When input power is lost, the UPS light bulb or wireless light bulb may detect this because the light sensor will no longer detect light coming out of the UPS light bulb or wireless light bulb at which point the bulb may switch over to the integrated power source until it may detect that input power is restored. Thus, the light sensor, whether remote or built directly into a light, will provide an indication when there is not light coming out and may effect a state change based on that information. In one use case, a remote light sensor transmitter is installed at a six inch recessed fixture where there is an R30 bulb and battery powered wireless lighting path lights are installed around the perimeter of the area. The remote light sensor transmitter is installed in the recessed fixture where it may detect whether light is coming out of that recessed fixture. If the remote light sensor transmitter detects that light is not coming out, it may transmit a command to the path lights installed around the perimeter to turn on. It is to be appreciated that the remote light sensor transmitter may have controls built in such as buttons, switches, dials etc to configure it for operation. For example, a dial may be present to set the threshold ambient light level that would trigger the transmitter to send a message to the lights it is controlling to turn them on, change light intensity etc. In another example, the remote light sensor transmitter may be disabled with a push button to turn off detection when a user does not wish it to be active. In some embodiments, the remote light sensor transmitter has multiple levels of ambient light that it may detect. By way of an example, it may detect when a high intensity discharge (HID) light is on (level 1), a backup or emergency light is on but the HID light is off (level 2) and when all light is off (level 3).

[0357] An embodiments of the wireless light bulb may take the form of an exit sign retrofit LED wireless light bulb such that the housing of the bulb is designed to fit into an exit sign (T5 tube, T6 tube etc), but the exit sign retrofit LED wireless light bulb also has a battery embedded in it such that an exit sign may operate without the need for an emergency lighting power circuit or a local power source. When power to the bulb is not detected, the exit sign retrofit LED wireless light bulb will automatically switch to battery power. Battery power may be rechargeable or non-rechargeable. If the battery power is rechargeable, there may be a charging circuit that manages the rechargeable batteries to maintain the charge level at an acceptable level for the exit sign. In alternate embodiments, the integrated power source is a super capacitor or the like. The exit sign retrofit LED wireless light bulb may contain red, green, white or any other color LED that may be desired for illumination.

[0358] In embodiments of the wireless light bulb or wireless lighting fixture containing batteries, there may be a heat shield or insulator mounted in a way to keep the temperature generated by the other components in the bulb or fixture, such as the heat sink, from increasing the temperature of the batteries. The heat shield or insulator may be constructed of ceramic, fiberglass or any other known material. In an alternate example, the shield or insulator separating the batteries from the other components may be mounted to the cover with some space left between the batteries and the thermal heat sink. The cover may have some ventilation holes or other methods to allow the heat to escape and keep the temperature of the batteries as low as possible. There may also be a heat shield or insulator through the heat sink and above the heat sink to shield or insulate the batteries from the heat sink and components. In alternate embodiments, there may be a thermal sensor connected to a point where a measurement of the battery temperature may be made and a change in the use of or charging of the batteries may be made. For example, if the battery temperature exceeds some set limit, a measurement of the temperature of the battery may trigger a reduction of the light intensity which would subsequently lower the battery temperature by lowering the current draw on the batteries and the amount of heat generated by the LEDs. In another example, the battery charging current may be reduced in response to the measurement of the battery temperature exceeding some set limit. This is important to optimize the usable life of the batteries in a wireless light bulb or wireless lighting fixture.

[0359] In one use case of an AC outlet adapter, the AC outlet adapter may be designed with a real time clock and a method that a user may program times during the day when the adapter will turn on and off as well as when the plugged in device will use battery power versus AC input power. The adapter may operate off of and pass through AC power, may contain an integrated wireless power source (batteries for example), a DC/AC inverter and control that is either wireless control or manual control such as a switch on the wireless AC outlet that may turn it on or off. The user may then plug in AC powered devices to the AC outlet adapter to power that device. By way of an example, the time of day AC outlet adapter may contain ON, OFF and PROGRAM pushbuttons. At the specific time of day that the user desires the adapter to automatically turn on, the user presses the ON and PROGRAM buttons simultaneously. A microcontroller, microprocessor, ASIC etc may contain a time source, such as a real time clock or the like, and may contain the intelligence to record that time and a state change based on that time such that every day at that time, the time of day wireless light bulb or battery powered fixture will automatically turn on. At another specific time during the day that the user desires the bulb or fixture to turn off, the user presses the OFF and PROGRAM buttons simultaneously.

[0360] In some embodiments, a virtual load control switch may be designed which contains circuitry to act as a load control switch receiving a load control or demand response command from the power company and may transmit over a communication interface to one or more wireless light bulbs or battery powered wireless lighting fixtures to turn off, change light intensity, switch over all or a portion of the load to battery power etc. In some embodiments, the unit may control the wireless light bulbs or battery powered wireless lighting fixtures in an installation in a demand response energy efficiency system, for load control purposes and the

like. This virtual load control switch may contain a timer such that after it receives a command from the power company to change to a lower energy consumption state, the virtual load control switch may start a timer and when the timer expires the virtual load control switch will send a command returning to the original state of operation or to another state of operation. The virtual load control switch may communicate with the power company infrastructure in a manner similar to a load control switch containing a relay that the power company may remotely control to cut power to devices that draw a lot of power like appliances, HVACs etc however the load control command would be received by the virtual load control switch and instead control any wireless light bulbs or battery powered wireless lighting fixtures that may be desired. In such a case, the virtual load control switch may be programmable. By way of an example, the virtual load control switch with an RF communication interface may communicate to a network of wireless light bulbs or battery powered fixtures that allows it to communicate with any wireless light bulb or battery powered fixture in the network. In one example, the virtual load control switch may be programmable over the RF communication interface. In another example, the virtual load control switch may have an Ethernet interface on the unit and have an IP address assigned to the interface. A software program running on the unit may allow a user to open a web browser and type in the IP address assigned to the unit. A graphical user interface served by the virtual load control switch may open up providing a method for the user to implement the desired functionality. The virtual load control switch may communicate with an intelligent electrical meter, smart meter, energy gateway, lighting control software and the like, over an appropriate communication interface using a protocol that allows the virtual load control switch, which controls the installation of wireless light bulbs and battery powered wireless lighting fixtures and meter etc. to exchange information. The virtual load control switch may allow a user to configure that the lighting turns off, that the lighting changes intensity levels, that the lighting switch some or all of the energy that is used over to an integrated power source in a wireless light bulb. By way of an example, a typical response to a load control command in lighting is to turn off or reduce the light intensity in either case reducing power consumption at the cost of a reduction in the light output. A wireless light bulb with an integrated power source, for example rechargeable batteries, allows a response to the load control command where the wireless light bulb uses stored power to power the light source partly or entirely. If the load control command intended to reduce the light intensity levels, the wireless light bulb may reduce the power consumption from the power company, but maintain the normal light intensity levels (the light intensity level prior to receipt of the load control command) by supplying some power from stored power in the wireless light bulb. In another example, the wireless light bulb turns off all power consumption from the power company and powers the light source only from stored power in the integrated power source. In some embodiments, the virtual load control switch may be designed into a wireless light bulb such that it receives the load control command directly from the power company. In some cases, a wireless light bulb in a network of or a coordinated group of wireless light bulbs may propagate the load control information to other wireless light bulbs such that

groups of wireless light bulbs may change state based on the load control command without having to have received it directly.

[0361] In alternate embodiments, a virtual load control switch may be designed which contains circuitry to act as a load control switch receiving a load control command from the power company and may transmit over a communication interface to one or more external light socket adapters, AC outlet adapters, AC outlet replacements, AC powered devices, AC circuit with embedded battery device designed with batteries embedded, wall switch or lighting control component and the like to turn off or switch over all or a portion of the load to battery power in the devices. In some embodiments, the virtual load control switch may be designed into a external light socket adapters, AC outlet adapters, AC outlet replacements, AC powered devices, AC circuit with embedded battery device designed with batteries embedded, wall switch or lighting control component and the like such that it receives the load control command directly from the power company.

[0362] In some embodiments, demand response may be implemented in wireless light bulbs by designing a receiver into the bulbs that may receive a load shed signal from a lighting panel over existing electrical wiring that the wireless light bulbs may use to either turn off lights, change lighting intensity levels or that the wireless light bulb switch some or all of the energy that is used over to an integrated power source in a wireless light bulb. In one example, the wireless light bulb may reduce the power consumption from the power company, but maintain the normal light intensity levels (the light intensity level prior to receipt of the load control command) by supplying some power from stored power in the wireless light bulbs.

[0363] In embodiments of the wireless light bulb or battery powered wireless lighting fixture, the devices may be able to receive commands from smart grid devices (smart meters, energy gateways, lighting control panels, software control systems and the like) and have the intelligence built inside the bulbs or fixtures to implement load control, receive pricing signals and manage demand based on dynamic pricing, reduce usage based on pricing or load reduction signals, allow access remotely to control the lighting installation, allow customers to manage the lighting locally and the like. By way of an example, a pricing signal may be received by one or more wireless light bulbs. A wireless light bulb with an integrated power source may have a pricing threshold set such that below that threshold when the pricing is such that it is advantageous to buy power, the wireless light bulb will consume power in addition to that necessary to power the light source and will charge the integrated power source. The stored power in the integrated power source may then be used at a later time when energy pricing is higher. In some cases, the wireless light bulb will have an upper pricing threshold that triggers the use of stored power and a lower price threshold that triggers the storage of power. In alternate embodiments, the wireless light bulbs contain a grid tie inverter and there is a net metering capability that allows the bulbs to return power to the grid. This ability to control the use of and return of stored power to the grid may be controlled by a smart meter, energy gateway, lighting control panel, software control systems and the like. In one use case, a wireless light bulb is designed as a six inch recessed fixture retrofit with rechargeable batteries embedded. A smart meter may communicate using ZIGBEE with the six inch recessed fixture retrofit wireless light bulb to implement any control men-

tioned herein. It is to be appreciated that any type of wireless light bulb or any communication interface type herein may be used in conjunction with the claimed subject matter.

[0364] In embodiments of external light socket adapters, AC outlet adapters, AC outlet replacements, AC powered devices, AC circuit with embedded battery device designed with batteries embedded, wall switch or lighting control component and the like, the devices may be able to receive commands from smart grid devices (smart meters, energy gateways, lighting control panels, software control systems and the like) and have the intelligence built inside to implement load control, receive pricing signals and manage demand based on dynamic pricing, reduce usage based on pricing or load reduction signals, allow access remotely to control the devices, allow customers to manage the device locally and the like. By way of an example, a pricing signal may be received by one or more devices. A device with an integrated power source may have a pricing threshold set such that below that threshold when the pricing is such that it is advantageous to buy power, the device will consume power in addition to that necessary to power the device and will charge the integrated power source. The stored power in the integrated power source may then be used at a later time when energy pricing is higher. In some cases, the devices will have an upper pricing threshold that triggers the use of stored power and a lower price threshold that triggers the storage of power. In alternate embodiments, the devices contain a grid tie inverter and there is a net metering capability that allows the devices to return power to the grid. This ability to control the use of and return of stored power to the grid may be controlled by a smart meter, energy gateway, lighting control panel, software control systems and the like.

[0365] In another illustrative embodiment, a version of the wireless lighting module targets stair light **3000** applications. With reference to FIG. **30**, illustrated is a perspective view of an embodiment of a stair light **3000**. In the illustrated embodiment, the stair light **3000** includes a housing **3010**, a plurality of LEDs **3020**, a motion sensor **3030**, logic **3040**, a power source **3050** and a light sensor **3060**. In the illustrated embodiment, the stair light **3000** includes 1 LED. In alternative embodiments, the stair light may include more LEDs **3020** to provide greater illumination or fewer LEDs **3020** to use less power. It is to be appreciated that the stair light **3000** can include any number of LEDs **3020**, and the LEDs **3020** can be positioned at substantially any locations with respect to one another as well as in comparison to the housing **3010**. It is noted that the stair light **3000** can be used in a many applications including a step light, a night light, a path light, a deck light and any other application that may benefit from the features and form factor of the stair light **3000**. In the illustrated embodiment the LED is the light source and is directed toward the ground to provide light to illuminate a dark area for walking up stairs, in a room to guide a user safely to a desired location, on the posts of a deck to illuminate a deck or in any area where a user needs additional light however alternate embodiments may point the LEDs in any direction that may be required for the application. In the illustrated embodiment, the stair light **3000** illuminates an area of approximately ten square feet. Alternate embodiments may include but are not limited to any known light source including LEDs, compact fluorescent and incandescent bulbs and can illuminate any size area required by the application.

[0366] In the illustrated embodiment, the housing **3010** is constructed of plastic. Alternatively, the housing **3010** can be

constructed of metal or any other known material. In one embodiment the housing can be waterproof, UV resistant and/or corrosion resistant for use outdoors or difficult environments. In one embodiment (not shown), the housing **3010** includes a mounting device for mounting the stair light, step light or nightlight to a wall, stair well, deck post, or other surface. Exemplary mounting devices include screws, nails, adhesive, suction cups, magnets, VELCRO, fixing posts, flanged heads of fasteners, and other known mounting devices. In this embodiment, the housing **3010** is configured to be mounted on a wall of a room, stairwell, closet, attic, basement, garage, storage area, shed, hallway, stairway, emergency exit path, alley or porch, or in any other indoor or outdoor location where light may be desired. It is to be appreciated that the housing **3010** can be any size and/or shape and is not limited to the depicted illustration (e.g., the housing **3010** can be dome shaped, pyramid shaped, cylindrical, rectangular, square).

[**0367**] In one embodiment the housing is mounted on an articulating bracket mounted to a surface that allows the user to mount the light to any angle wall or surface and articulate the light straight up, down or at any angle desired. In another embodiment, the housing can be mounted to a stake or post made of plastic, metal or any other known material allowing any of the mounting devices described to be used to mount the light onto the stake or post. The stake or post can be driven into the ground, can be on a tripod or stand to be free standing or fixed to the area or can be attached to an area in any possible way to create a path light that can illuminate walkways, sidewalks, alleys, or in any other indoor or outdoor location where light might be desired. FIG. **32** shows an example of path light created by mounting the stair light **3210** to a stake **3220** that can be driven into the ground.

[**0368**] As shown in the illustrated embodiment, the stair light **3000** includes a power source **3050**, such as a battery. In the illustrated embodiment, the stair light is powered by 3 C batteries. In another illustrated embodiment, as shown in FIG. **31**, the sensor light **3100**, a smaller version of the stair light that emits less light and is in a smaller housing, three "AA" size alkaline batteries are used as a power source. In the illustrated embodiment, the sensor light **3100** includes a housing **3110**, a plurality of LEDs **3120**, a motion sensor **3130**, logic **3140**, a power source **3150**, and a light sensor **3160**. It should be understood that any number and type of known batteries may be used, including without limitation all known alkaline and nickel-cadmium batteries, depending on size and power requirements. According to another example, the power source can be any number and type of rechargeable batteries and/or non-rechargeable batteries. Pursuant to a further illustration, the power source can be a combination of a solar cell and one or more batteries (e.g., rechargeable, non-rechargeable, . . .). Thus, for instance, a battery can supplement the power supplied by the solar cell (or vice versa) and/or the solar cell can recharge a battery. In some embodiments of the foregoing arrangement, a solar cell may be diode or-ed with a battery and the battery may be non-rechargeable.

[**0369**] The battery **3050** supplies power to the stair light **3000** to enable installing, moving, replacing, etc. the unit at substantially any indoor or outdoor location while mitigating the need for expensive and time consuming wiring and/or utilization of aesthetically displeasing and potentially inconvenient cords commonly associated with conventional lighting.

[**0370**] In alternate embodiments the power source may include a fuel cell, such as and without limitation a hydrogen fuel cell, a reformed methanol fuel cell, or the like.

[**0371**] In some embodiments the power to the unit may be powered directly from AC or from a DC input that comes from an external AC to DC converter. In other embodiments, the unit will contain rechargeable batteries such that the unit can be recharged by connecting the unit to an AC power source, cabling to an AC power source or plugging the unit into a recharging base.

[**0372**] With continued reference to illustrated embodiment shown in FIG. **30** the input component is a motion sensor. When the motion sensor **3030** detects motion, logic **3040** determines if the motion is above a predetermined threshold. If the motion is above the predetermined threshold, the logic **3040** instructs an LED controller to turn on at least one LED. The motion sensor will only be operational if the light sensor **3060** detects that detected light is at a low enough level to allow the unit to turn on (i.e. the unit will only work in the dark or whatever low light level is set by the light sensor and its detection circuitry). After the at least one LED is turned on, the logic starts a timer. The logic will then instruct the LED controller to turn off the at least one LED if no motion is detected before the timer reaches a predetermined timer threshold. If motion is detected before the timer reaches the timer threshold, the LED will remain on and the timer will reset to the timer starting point. The illustrated embodiment includes this auto shutoff feature to extend battery life. This feature is factory set via a timer that expires such that after turn on, if there is no reactivation of the control to turn the LEDs on, the unit will automatically turn the LEDs off when the timer expires.

[**0373**] In the illustrated embodiment, the timer consists of an RC electrical circuit that discharges to the factory set voltage threshold over some period of time at which time, if not retriggered, will automatically shut off the LEDs. Other embodiments may have a timer built in any known timer circuit. This feature may be set by toggling or setting a switch, may be dial selectable, may be set by a potentiometer, may be programmable directly or by remote, may be responsive to a battery's level, may include fade-to-off effect and so on. A second feature may have two or more auto shutoff levels set by multiple timers. For example the auto shutoff feature may control the light from bright to dim when the first timer expires and from dim to off when the second timer expires and so on.

[**0374**] The illustrated embodiment includes a circuit that allows the unit to glow at a level such that the unit can be a marker in a dark environment and when motion is detected it turns on to a bright level for illumination to a level that a user can find their way on stairs, steps or where a night light would be desirable. An alternate embodiment would include a circuit that allows the unit to be on at a low light level to illuminate an area with enough light to see the area from a distant and when motion is detected it turns on to a bright level for illumination to a level that a user can find their way on stairs, steps or where a night light would be desirable. In another embodiment, the low light level blinks at some rate to provide a marker until a sensor triggers transitioning to a bright level. In some embodiments, the control of the brightness level at glow, low, bright or any brightness level the user may desire is controlled by a dial, buttons, switches, RF/IR remote or any other known control to allow the user to set the different light levels to the individual user preference.

[0375] In the illustrated embodiment, the shape of the hollowed out face in the housing **3010** is designed to enhance the appearance of the glow level of the LEDs as well as better reflect the light when the light is turned to a bright light level. In other embodiments, an optical lens or lenses or reflectors to direct the light, reflect the light or change the viewing angle of the LEDs. The housing of the unit may include any number of optical elements. The optical elements may serve to focus, diffuse, filter, collimate, or otherwise affect light produced by the LEDs **3020**. In embodiments, the optical elements may include one or more lenses, reflectors, optical filters, aperture, and so on. The lenses may be fixed, a multiple lens array, adjustable, and so on. The lenses or reflectors may be manually adjustable, motorized with direct control with switches on the unit for adjusting the direction or characteristics of the light source, motorized with a remote control for adjusting the direction or characteristics of the light source through RF or IR control or it may detect motion and automatically adjust the lenses or reflectors to aim the light in the direction of the motion either to illuminate an area or as a deterrent for security reasons or as a deterrent for animals.

[0376] In another embodiment, the light can be programmed to fade over time such that the light is activated and slowly fades until it reaches either a glow level or a low light level. An example of this application is a light in the bedroom of a child that is on when they go to bed at night, but fades over time to a glow level or a low light level as they fall asleep. The design can include any controls, methods and circuits by which to achieve multiple light levels. In addition the design may include methods and circuits to achieve constant current control to achieve consistent brightness at the different light levels.

[0377] A feature can be added such that when the batteries are detected to reach a predetermined low level of charge, the light will blink to indicate to the user that the batteries need to be replaced. In an alternate embodiment, the light may include a push button with a light bar that would show the battery level when the button is pushed.

[0378] The stair light may also include an on/off switch, a push button to disable the sensor from activating the light for some period of time or a push button providing a sleep function that will shut the light off until the next time the light is enabled to operate when the light sensor senses a transition from light to dark. An alternate embodiment could include a sleep/awake button or buttons such that the light can be put into sleep mode either until that button or another button is pushed to transition back to operational or until the next time the light is enabled to operate when the light sensors senses a transition from light to dark. Alternate embodiments may also allow for control of the light by time of day or timer controls such as dials to set when the light is enabled and when it is disabled. The time of day or timer to control the light can be set in any manner can be conceived of.

[0379] In the illustrated embodiment, the stair light **3000** includes a passive infrared sensor configured to detect motion. In one embodiment, the passive infrared sensor has a range of approximately 30 feet and a viewing angle of 110 degrees. In alternative embodiments, the passive infrared sensor may have a range and viewing angle of any known passive infrared sensor. In one alternative embodiment, the passive infrared sensor is removably connected to the unit so that a user may connect any appropriate sensor. In some embodiments, the passive infrared sensor may be replaced or

enhanced by a radar sensor, an ultrasound sensor, or any and all other form of motion sensor.

[0380] In other embodiments, any and all sensors may include a detection threshold or false detection rate that can be configured according to a user's preference. For example and without limitation, a light sensor may be configured to detect when incoming light crosses a user-preferred intensity threshold. A variety of other such examples will be appreciated, all of which are within the scope of the present disclosure.

[0381] In the illustrated embodiment, a Fresnel lens enables motion detections. The motion detector includes a Fresnel lens that guides infrared light over the PIR sensor in a substantially repeating pattern as a heat source (such as a person, vehicle, and so on) passes in front of the lens. In embodiments, the Fresnel lens may be selected to provide a desired zone of coverage. It will be understood that a variety of embodiments of motion detectors including the Fresnel lens are possible.

[0382] With continued reference to FIG. 30, when the motion sensor **3030** detects motion, logic **3040** determines if the motion is above a predetermined threshold. If the motion is above the predetermined threshold, the logic **3040** instructs an LED controller to turn on at least one LED **3020**. After the at least one LED **3020** is turned on, the logic **3040** starts a timer. The logic **3040** will then instruct the LED controller to turn off the at least one LED **3020** if no motion is detected before the timer reaches a predetermined threshold.

[0383] The unit can be controlled by any type of input signal that can be leveraged by the logic **3040** to manipulate operation of the LEDs **3020**. Thus, the input component can be a radio frequency (RF) receiver that can obtain an RF signal communicated from an RF transmitter (not shown) that can be utilized by the logic **3050** to control operation of the LEDs **3020**. According to this example, the RF signal can be deciphered by the input component to effectuate switching the LEDs **3020** to an on or off state, changing a light color or a light intensity provided by the LEDs **3020**, and the like. Additionally or alternatively, the input component can be one or more sensors that monitor a condition, and monitored information yielded by such sensor(s) can be utilized to effectuate adjustments associated with the LEDs **3020**.

[0384] It is to be appreciated that any type of sensor(s) can be utilized in connection with the claimed subject matter instead of or in conjunction with a motion sensor. For example, the sensor(s) can be one or more of infrared sensors, light sensors, proximity sensors, acoustic sensors, motion sensors, carbon monoxide and/or smoke detectors, thermal sensors, electromagnetic sensors, mechanical sensors, chemical sensors, and the like. According to another example, the input component can be a connector, port, etc. that couples to a disparate device, sensor, etc. to receive the input signal.

[0385] It is also appreciated that any combination of sensors can be utilized in connection with the claimed subject matter. The illustrated embodiment is a combination of a light sensor that will conserve battery life by only allowing the LEDs to turn on when there is a low level of light in the environment. When there is enough light in the environment, the motion sensor will control the LEDs to turn on when motion is detected. An alternate embodiment includes an RF receiver and motion sensor in the light with an RF transmitter remote that can override motion sensor control of the unit when a user desires that it is turned on for an extended period of time or controlled remotely rather than by motion. In one

embodiment, the sensor light **3100** is designed with a motion sensor and an RF receiver. One or more sensor lights **3100** are controlled by either the motion sensors on the lights, by an RF remote control or alternately by an RF wall switch. The RF control element is used to turn on and off both sensor lights. In an alternate embodiment, the remote control element contains a motion sensor and an RF transmitter to send the on and off command to the two sensor lights. In the alternate embodiment, the sensor lights have an RF receiver but may or may not have a motion sensor.

[0386] Another alternative embodiment includes one or more units used as stair lights or path lights with an RF receiver as the input component controlling the light source and an RF transmitter remote combined with a motion sensor. An example use of this embodiment is a driveway sensor that detects a car triggering the motion sensor to send an RF transmission to the light when the car enters the driveway. The light can stay on for some user set amount of time, then auto shutoff.

[0387] The combination of sensors can also be used to communicate between units and network the units together. For example, the units are a combination of RF transceiver and motion sensor. If one unit detects motion, it sends out a message to all units via its RF transmitter to turn all of the units on. Units can also receive a message via its RF receiver and retransmit it via its RF transmitter to extend the range of lights beyond what is within the range of the initial unit that detected motion. The triggering method can be any method sensor described and the sending of signals from one unit to another can be RF/IF, wired or wireless network or wired with any electrical control mechanism between lights.

[0388] In an alternate embodiment, a group of lights that have a light sensor and are controlled by RF/IR are used as path lighting. When the light sensor detects low light levels, the light will be turned on to a glow level marking the path. When the user wants to illuminate the path, expecting visitors for example, an RF remote control or RF wall switch can be used to transmit a signal or control message to the group of lights to turn on to a bright level. The user can also transmit a signal or control message to the light to return them to glow mode or turn them off. An auto shutoff feature can also be included such that after some period of time at the bright level, the light will automatically return to glow mode.

[0389] In another embodiment, the stair lights or path lights are used for emergency purposes to light up a walkway when there is a power outage. The stair light or path light has a light source and RF receiver to control the light source. A circuit that can detect when AC power is not present is combined with an RF transmitter in a housing. The RF transmitter unit can be plugged into an electrical socket, hardwired to an AC wall switch prior to the switch, wired directly in at the breaker box or at any point in a power distribution system that a user may want to detect a drop out in power. Upon detecting the loss of AC power at the monitor point, a signal is sent to the lights turning them on, emergency lighting is provided and the path to a safe area is illuminated. In an alternate embodiment, the RF transmitter unit is connected to the residential or commercial building security or safety system. If an alarm is present in the security or safety system that requires emergency lighting, the system will send a command to the lights to turn them on.

[0390] In another embodiment, the LEDs or OLEDs are designed into a strip that can be attached to the floor, wall, ceiling, sidewalk, pathway, stairwell or any known walkway

or structure. The strip can be attached with screws, nails, adhesive, suction cups, magnets, VELCRO or in any other known way. The strip can be battery powered and have a motion sensor built in such that the light strip will glow all of the time until motion is detected, then turn on brighter. After some period of time, the light strip will go back into glow mode. The light strip can also contain a light sensor such that the light will only turn on if the level of ambient light drops below a certain level. In an alternate embodiment, the light strip contains an RF receiver and is controlled by an RF transmitter remote control. It is to be appreciated that any type of sensor(s) can be utilized in connection with the claimed subject matter instead of or in conjunction with a motion sensor. It should be understood that any type of wireless power defined can be used in connection with the light strip.

[0391] An example application is for use in a hallway to light up a path for children during the night to the bathroom. It should also be understood that the strip can be designed such that multiple separate light strips can light up to illuminate an entire path if one strip is activated. In this case, the light strips would need to be networked together and the first activated light strip would need to communicate to the other strips to turn on to a bright level. Another example application is that the light strips have a smoke detector or thermal sensor integrated or receive a message from an alarm system to light up a path to a fire exit. Note that in addition to illumination, the light strips may also use different color LEDs to identify different paths. For example, a path of green LEDs leads to a bathroom and a path of red LEDs leads to a fire exit. It is to be appreciated that the LED strip can be made of multicolor LEDs such that a user can select the color upon installation. In the previous example, there are two identical light strips and there is a switch on the light strip allowing the user to set the light strip to be a green light strip if the switch is in one position or a red light switch if the switch is in another position.

[0392] An alternate application is for a media room environment in which either stair lights or strip lights are used and are controlled by RF/IR. The user can allow the lights to glow when the television is on and use the remote to turn on the lights to a brighter level when desired. Alternatively, in addition to RF/IR control directly, the lights can also respond to controls from the television or media system remote control such that when the television is off, the recording is paused or stopped. Upon any other detectable state of the media system, the lights will turn on to a bright light but under normal television viewing conditions, the lights will be in glow mode. It is appreciated, that the media room lighting system can be programmed in any manner it is capable of in response to any detectable state of the media system. It is also to be appreciated that instead of for illumination, the lighting system can be constructed of any color lights possible and the control system can set the color of light. For example, the user can hold down a button on the remote and the lighting system will cycle through the possible light colors until the light is the desired colored at which time the user releases the button on the remote leaving the lighting system at the desired color of light.

[0393] The previously mentioned lights and lighting systems can be grouped into kits to meet specific user applications. A fall prevention kit can be constructed of any mix of stair lights, step lights, night lights, path lights or strip lights in a kit to allow installation in a residential or commercial building to prevent falls. The target market for such a kit is the

elderly, but it can be used by any consumer or business motivated to prevent injurious falls. FIG. 33 shows the components of an example fall prevention kit 3300. An example fall prevention kit includes six motion sensor stair lights 3310, two RF controlled stair lights 3320 with one RF remote control 3330 and associated mounting hardware.

[0394] A deck lighting kit can also be constructed or assembled. This kit allows a user to install battery powered, RF controlled lights to the posts of the deck such that installation included no AC wiring. An example of this kit would include eight RF controlled stair lights with one RF wall mount switch and associated mounting hardware.

[0395] A power outage kit can also be sold. The power outage kit can include all of the lights, batteries and temporary or permanent installation hardware to allow the user to install battery powered lighting throughout their house or business in the event that there is a power outage. An example power outage kit would include a plastic case containing sixteen motion sensor stair lights with batteries that have adhesive on the back to allow it to stick to a wall. In the event of a power outage, the user can quickly walk through their house, for example, and install the lights by remove the backing to the adhesive and attaching the light to the wall.

[0396] FIG. 34 shows an example use scenario 3400 of the stair light 3410 on a deck at the top stair to the deck. The motion sensor in the stair light is designed with a wide angle of motion detection such that it will trigger the stair light to turn on when motion is detected on the stairs or on the deck. The stair light also contains a light sensor such that during the day it is turned off but through the night, in low levels of light, the stair light will glow at a low level. This is a key to providing a marker light such that there is enough light for a user to identify the stairs or the edge of the deck where the stairs start. As the user approaches the stairs, the stair light will turn on illuminating to a brighter level enough for the user to see their way. The glow mode 3420 provides additional safety to mark the location of the stairs and edge of the deck and when the stair light turns on to the brighter level as in 3410, the stair light provides additional illumination of the area for the user to see their way.

[0397] FIG. 35 shows an example use scenario 3500 of three RF controlled stair lights 3510 mounted on a stair way and an RF remote control 3520 that can be handheld, mounted to the wall by bracket or mounted on two wall screws or nails that controls the three stair lights. An RF remote control with an on button and an off button is shown. When the on button is pushed, a message containing timing and synchronization information, a command and a unique identifier (channel number, unit address number etc.) is transmitted via the RF transmitter circuit. The message transmission can be modulated in any manner known in RF communication (on off keyed, OOK, amplitude shift keyed ASK etc.). That message is received by all three RF controlled stair lights. The stair lights receive the message, demodulate it, process the command and unique identifier and either ignore the command or change state appropriately. In this use scenario, the two commands are turn on and turn off. The unique identifier is hard coded into the remote control and the three stair lights such that the remote controls the three stair lights. The unique identifier can be set by dip switch, rotary switch etc on both the remote control and stair lights. The three stair lights can also learn the unique identifier of the remote control and thereafter respond to that unique identifier. For example, after the batteries are inserted into the stair lights, the unique iden-

tifier in the first message received will be stored in the stair lights. Thereafter, that remote control will control those stair lights.

[0398] The use scenario can be expanded such that there is no remote control but rather only the three stair lights 3510. In this use scenario, the stair lights contain a motion sensor, RF transmitter and RF receiver. FIG. 35 shows three stair lights. The stair lights can be controlled either by motion detection or by a message received by the RF receiver. Thus, in this use scenario, if motion is detected by one stair light, it can turn its light on and also send a message by its RF transmitter to turn on the other stair lights. The other stair lights will receive a message to turn on by their RF receivers and will subsequently turn on. They can also then send a message by their RF transmitters to turn on other stair lights. This message will also contain an indication that this is a retransmitted message (not from the original source of the motion detection). Thus, a single motion detection by one stair light can turn on many stair lights even those not within range of its RF transmitter. When the originating stair light reaches its auto shutoff time, it can turn its light off and send a message by its RF transmitter to turn off the other stair lights. There are many use scenarios that can result from this function. For example, the stair light can be mounted to a stake as in FIG. 32 to become a path light. Path lights can be installed throughout a large garden or backyard such that motion detection by any of the path lights will result in a flood of messages through the network of path lights to ultimately turn any on any path light within range of any other path light. As another example, several path lights can be installed along a long driveway perhaps several hundred yards long. The path lights can glow and when any path light detects motion, it can send a message to turn on or off the other path lights that will be flooded through the network of path lights. In another example, the stair light can be used and mounted on the perimeter of a large building every 25 feet. If motion is detected at any point around the perimeter of the building all of the stair lights will be illuminated. It is to be appreciated that the scope of messages and how the networking of the lights works can be as sophisticated or simple as is required by the application. It is also to be appreciated that any control mentioned herein can be built into messages and be transmitted through the network of lights.

[0399] In alternate embodiments, a network of wireless lighting modules may be created by embedding an RF transceiver with intelligence (microcontroller, microprocessor, integrated circuit etc.) in the wireless lighting modules and using a communication protocol between the modules to control a plurality of modules to accomplish a task, such as described herein. In embodiments there may be other control sources designed to communicate through the network, such as wall switches, key fobs, remote controls, RF adapters, and the like, that can plug into a computer and be controlled by a software program, etc. that may also connect to the network and control wireless lighting modules in the network. By way of an example, the wireless lighting modules may be a combination of RF transceiver and motion sensor. For instance, if one module detects motion, it may send out a message to other modules via its RF transmitter to turn other modules on to a specific brightness level. Modules may also receive a message via its RF receiver and retransmit the message via its RF transmitter to extend the range of lights beyond what is within the range of the initial unit that detected motion. In an alternate example, the control source may be one or more

remote controls with a push button that is pressed to turn the lights on and a push button that may be pressed to turn the lights off with a unique identifier that can be set that may select the wireless lighting modules to control, and the like. When either button is pressed, a command may be transmitted by a remote control to the network to control one or more modules that receive it. The command may also be propagated through the network of modules via the RF transceiver in each module to control a portion of or the entire network of wireless lighting modules. It is to be appreciated that the modules may use other types of networking protocol (e.g. routing, flooding, etc.) that may effectively distribute state information through the network of wireless lighting modules. In embodiments, when an auto shutoff timer of the originating wireless lighting module times out, it may send an off command which may also be propagated through the network of light modules to shut them all off. The triggering method may utilize any sensor described herein, the type of control of the wireless lighting module may be any control mentioned herein, and the sending of signals from one wireless light module to another may be RF/IR, wired or wireless network (e.g. WIFI, ZIGBEE, X10 etc.) wired with an electrical control mechanism between wireless lighting modules that can be defined, and the like. It is also to be appreciated that any standard or proprietary protocol (e.g. networking protocols such as IP, TCP, UDP, routing protocols etc. and physical layer protocols such as WIFI, Ethernet, ZIGBEE etc.) may be used to communicate between wireless lighting modules. In embodiments, a unique identifier of a wireless lighting module may be the identifier used in a standard protocol (e.g. IP address, Ethernet or WIFI MAC address, PAN ID, House Code, etc.), a proprietary protocol (set at dip switch, identifier programmed into the wireless lighting module etc.), and the like. It is to be appreciated that the network of lights in the lighting installation may be comprised of wireless lighting modules, wireless light bulbs, a lighting fixture, any mix of these, and the like.

[0400] In addition to wireless lighting modules, a repeater device that can communicate with the network of wireless lighting modules may be designed to extend the range of the network. This device may or may not have a light source. The repeater device may be installed in locations with a primary function of extending the range of the network of wireless lighting modules or filling in areas with poor or no coverage. The repeater device may be powered by any form of wireless power mentioned herein or may be designed to connect to AC power. The repeater device may also contain an RF/IR, wired or wireless network (WIFI, ZIGBEE, X10 etc.) or wired with any electrical control mechanism that it requires to be communicate with wireless lighting modules. It is also to be appreciated that any standard or proprietary protocol (e.g. networking protocols such as IP, TCP, UDP, routing protocols etc. and physical layer protocols such as WIFI, Ethernet, ZIGBEE etc.) may be used to communicate between repeaters and wireless lighting modules. The repeater device may communicate with wireless lighting modules, wireless light bulbs or any mix of the two.

[0401] In another illustrative embodiment, a version of the wireless lighting module may target wireless remote controlled LED spotlight applications. With reference to FIG. 36, illustrated is a perspective view of an embodiment of an RF Spotlight 3600. In the illustrated embodiment, the RF Spotlight 3600 includes a housing 3610, an adjustable base 3620, a plurality of LEDs 3630, an RF receiver 3640, logic 3650, a

power source 3660, a motion sensor 3670 and RF transmitter 3680. In the illustrated embodiment, the RF Spotlight 3600 includes 1 LED. In alternative embodiments, the RF Spotlight may include more LEDs 3630 to provide greater illumination or fewer LEDs 3630 to use less power. It is to be appreciated that the RF Spotlight 3600 can include any number of LEDs 3630, and the LEDs 3630 may be positioned at substantially any locations with respect to one another as well as in comparison to the housing 3610. In the illustrated embodiment the LED is the light source and the housing may be articulated using the adjustable base 3620 then locked in place to direct the light output to illuminate a dark area where a user needs additional light, to direct the motion sensor toward the area where motion needs to be detected or both. Alternate embodiments may point the housing or LEDs in any direction that may be required for the application. In the illustrated embodiment, the RF Spotlight 3600 illuminates an area of approximately three hundred fifty square feet. Alternate embodiments may include but are not limited to any known light source including LEDs, compact fluorescent, incandescent bulbs, and the like, and can illuminate any size area required by the application.

[0402] As shown in the illustrated embodiment, the RF Spotlight 3600 includes a power source 3660, such as a battery. In the illustrated embodiment, the spotlight is powered by 3 D batteries. It should be understood that in alternate embodiments any number and type of known batteries may be used, including without limitation all known alkaline and nickel-cadmium batteries, depending on size and power requirements. According to another example, the power source may be any number and type of rechargeable batteries and/or non-rechargeable batteries. Pursuant to a further illustration, the power source may be a combination of a solar cell and one or more batteries (e.g., rechargeable, non-rechargeable, and the like). Thus, for instance, a battery can supplement the power supplied by the solar cell (or vice versa) and/or the solar cell can recharge a battery. In some embodiments of the foregoing arrangement, a solar cell may be diode or-ed with a battery and the battery may be non-rechargeable.

[0403] In embodiments, the power source 3660 may supply power to the RF Spotlight 3600 to enable installing, moving, replacing, etc. the unit at substantially any indoor or outdoor location while mitigating the need for expensive and time consuming wiring and/or utilization of aesthetically displeasing and potentially inconvenient cords commonly associated with conventional lighting.

[0404] In alternate embodiments the power source may include a fuel cell, such as and without limitation a hydrogen fuel cell, a reformed methanol fuel cell, or the like. In alternate embodiments, the power source may include a capacitor, array of capacitor, super capacitor, and the like, to store energy to be used as a power source similar to a battery. It should be understood that any type of or combination of wireless power sources described herein may be used in connection with the RF Spotlight 3600.

[0405] The illustrated embodiment may include an RF receiver 3640 and motion sensor 3670 in the RF Spotlight 3600 with an RF transmitter 3680 remote that may override motion sensor control of the unit when a user desires that it is turned on for an extended period of time or controlled remotely rather than by motion. In the illustrated embodiment, there is also a light sensor that may disable the RF Spotlight 3600 during the day time. In one alternate embodiment, there may be no light sensor and the RF Spotlight 3600

contains only an RF receiver **3640** and motion sensor **3670**. In another alternate embodiment, there may be no motion sensor and the RF Spotlight **3600** contains only an RF receiver **3640**. In another alternate embodiment, there may be no RF receiver **3640** and the Spotlight only contains a motion sensor and may contain a light sensor. It is to be appreciated that any combination of wireless control mentioned herein may be used in conjunction with the RF Spotlight **3600**.

[**0406**] The illustrated embodiment includes an RF transmitter **3680**. The RF transmitter **3680** may send commands to the RF Spotlight **3600** via the RF receiver **3640** to control the logic **3650** to control the light source to turn it on or off, modify the brightness, modify the color or modify any other characteristic of the light source. In the illustrated embodiment, the user may select a channel number on the RF transmitter **3680** and RF Spotlight **3600** through a dip switch on each unit. It is to be appreciated that the channel number may be set by any method mentioned herein. When a button is pushed on the RF transmitter **3680**, a message containing the command and channel number may be sent. Any RF Spotlight **3600** within range of the RF transmitter **3680** may receive and respond to the command. In alternate embodiments, the RF Spotlight **3600** may also contain an RF transmitter circuit designed in the spotlight such that a network of RF Spotlights can be created allowing spotlights to be controlled beyond the range of the originating RF transmitter.

[**0407**] In another illustrative embodiment, a version of the wireless lighting module may target wireless remote controlled LED ceiling light applications. With reference to FIG. **37**, illustrated is a perspective view of an embodiment of an RF Ceiling Light **3700**. In the illustrated embodiment, the RF Ceiling Light **3700** may include a housing **3710**, a mounting bracket **3720**, a plurality of LEDs **3730**, an RF receiver **3740**, logic **3750**, a power source **3760**, a motion sensor **3770**, RF transmitter **3780**, and the like. In the illustrated embodiment, the RF Ceiling Light **3700** may include an LED. In alternative embodiments, the RF Ceiling Light **3700** may include more LEDs **3730** to provide greater illumination or fewer LEDs **3730** to use less power. It is to be appreciated that the RF Ceiling Light **3700** may include any number of LEDs **3730**, and the LEDs **3730** may be positioned at substantially any locations with respect to one another as well as in comparison to the housing **3710**. In the illustrated embodiment the LED is the light source and the housing **3710** may be removed from a mounting bracket **3720**, to replace the batteries for example, then locked back in place for normal operation. It is to be appreciated that there may or may not be a mounting bracket **3720** and that the housing **3710** may be mounted directly to the mounting surface (ceiling, wall etc.) with any mounting mechanism mentioned herein. In alternate embodiments, the mounting bracket **3720** may be an articulating bracket that allows the ceiling light to be mounted to the bracket which may be mounted to the mounting surface. The bracket and thus the ceiling light may be pointed in any direction the user may require to point the LEDs **3730**, point the motion sensor **3770** in the desired direction to detect motion or to point the unit in any desired direction as required by the application. In the illustrated embodiment, the RF Ceiling Light **3700** illuminates an area of approximately ninety square feet. Alternate embodiments may include but are not limited to any known light source including LEDs, compact fluorescent, incandescent bulbs, and the like, and may illuminate any size area required by the application.

[**0408**] As shown in the illustrated embodiment, the RF Ceiling Light **3700** includes a power source **3760**, such as a battery. In the illustrated embodiment, the ceiling light is powered by 4 C batteries. It is to be appreciated that in alternate embodiments any number and type of known batteries may be used, including without limitation all known alkaline and nickel-cadmium batteries, depending on size and power requirements. According to another example, the power source may be any number and type of rechargeable batteries and/or non-rechargeable batteries. Pursuant to a further illustration, the power source may be a combination of a solar cell and one or more batteries (e.g., rechargeable, non-rechargeable, . . .). Thus, for instance, a battery may supplement the power supplied by the solar cell (or vice versa) and/or the solar cell can recharge a battery. In some embodiments of the foregoing arrangement, a solar cell may be diode or-ed with a battery and the battery may be non-rechargeable.

[**0409**] In embodiments, the battery **3760** may supply power to the RF Ceiling Light **3700** to enable installing, moving, replacing, etc. the unit at substantially any indoor or outdoor location while mitigating the need for expensive and time consuming wiring and/or utilization of aesthetically unpleasing and potentially inconvenient cords commonly associated with conventional lighting.

[**0410**] In alternate embodiments the power source may include a fuel cell, such as and without limitation a hydrogen fuel cell, a reformed methanol fuel cell, or the like. In alternate embodiments, the power source may include a capacitor, array of capacitor, super capacitors, and the like, to store energy to be used as a power source similar to a battery. It should be understood that any type of wireless power described herein may be used in connection with the RF Ceiling Light **3700**.

[**0411**] The illustrated embodiment may include an RF receiver **3740** and motion sensor **3770** in the RF Ceiling Light **3700** with an RF transmitter **3780** remote that may override motion sensor control of the unit when a user desires that it is turned on for an extended period of time, controlled remotely rather than by motion, and the like. In the illustrated embodiment, there may also be a light sensor that disables the RF Ceiling Light **3700** during the day time. In one alternate embodiment, there may be no light sensor and the RF Ceiling Light **3700** may contain only an RF receiver **3740** and motion sensor **3770**. In another alternate embodiment, there may be no motion sensor and the RF Spotlight **3700** may contain only an RF receiver **3740**. In another alternate embodiment, there may be no RF receiver **3740** and the ceiling light may only contain a motion sensor and may or may not contain a light sensor. It is to be appreciated that any combination of wireless control mentioned herein may be used in conjunction with the RF Ceiling Light **3700**.

[**0412**] The illustrated embodiment may include an RF transmitter **3780**. The RF transmitter **3780** may send commands to the RF Ceiling Light **3700** via the RF receiver **3740** to control the logic **3750** to control the light source to turn it on or off, modify the brightness, modify the color, or modify any other characteristic of the light source. In the illustrated embodiment, the user may select a channel number on the RF Transmitter **3780** and RF Ceiling Light **3700** through a dip switch on each unit. It is to be appreciated that the channel number may be set by any method mentioned herein.

[**0413**] Alternate embodiments of the RF Ceiling Light may be designed with a different housing that allows installation in a suspended grid ceiling system in locations typically occu-

pied by 1×1, 2×2, 2×4 size ceiling tiles or the like. In this embodiment, the housing may contain any of the features of the RF Ceiling Light, but is designed in a ceiling tile form factor. In alternate embodiments, the housing may be designed in any form factor to be used in place of a fluorescent fixture such as but not limited to high bay fixtures, lay-in fixtures, strip fixtures, under cabinet fixtures, wall mount fixtures, wrap around fixtures, and the like. In embodiments, the wireless lighting module may be designed to fit into place in the socket of the fixture (i.e. as a bulb replacement) or the entire wireless lighting module fixture may be the same form factor as the fluorescent fixtures listed and be applicable for use in similar applications. The ceiling light may contain non-rechargeable or rechargeable batteries. In alternate embodiments, the wireless lighting module may have any type of connector on it that allows for charging by connection to a mating connector and that provides the AC or DC power source. In some embodiments the ceiling light may also allow a connection to an AC input and may contain the required circuitry to convert AC to DC for the light source and wireless control. In some embodiments, the RF Ceiling Light may replace a fluorescent light that is connected to a resistive, reactive, or electronic ballast in which case the ceiling light may also contain circuitry to take the output of the ballast and convert it to DC power suitable for the light source and wireless control. By way of an example, a version of the RF Ceiling Light containing an RF receiver and a motion sensor may be designed into a housing that fits into a 2×2 ceiling grid. The RF Ceiling Light may also contain rechargeable batteries and an AC-to-DC converter and ballast conditioning circuit to connect to a ballast in the case where the RF Ceiling Light is a retrofit of a standard fluorescent fixture. There may also be intelligence (microcontroller, microprocessor, integrated circuit etc.) inside the RF Ceiling Light such that it can be programmed to draw power from the AC input, from the rechargeable batteries, or both. The intelligence may use a real time clock and be programmed to use the AC input and charge the batteries during off peak billing times and use battery power during on peak billing times such that there is an overall cost savings in energy usage. The unit may be programmed for operation based on a Time of Use (TOU) price plan from the energy company. The rechargeable battery capacity may or may not be enough to power the light source for the entire duration of the on peak billing time. In such a case, the intelligence may be able to switch between or control a sharing of the load between battery power and AC input power based on a measurement of battery capacity level, power use from the embedded batteries and from the AC input or any other measurable parameter that allow for an optimization for cost or minimize power consumption of the combined use of embedded batteries and AC input power.

[0414] In an alternate embodiment the RF Ceiling Light **3700** may include an RF transmitter built into the ceiling light such that there is both an RF transmitter and RF receiver. In addition, there may or may not be a motion sensor, light sensor, or any other form of wireless control or sensor mentioned herein. A network of RF Ceiling Lights **3700** may be created by embedding an RF transceiver with intelligence (microcontroller, microprocessor, integrated circuit etc.) in the ceiling light and using a communication protocol between the ceiling lights to control any size group of ceiling lights to accomplish any task described herein. Other control sources designed to communicate through the network such as wall switches, key fobs, remote controls, RF adapters, and the like,

that can plug into a computer and be controlled by a software program, etc. may also connect to the network and control the ceiling lights in the network. By way of an example, if one ceiling light detects motion, it may send out a message to all ceiling lights via its RF transmitter to turn all of the ceiling lights on to a specific brightness level. When that ceiling light reaches an auto shutoff time, it may then send out a message to one or more ceiling lights via its RF transmitter to turn one or more of the ceiling lights off, set them to a glow, set them to a low level of light, and the like. Ceiling lights may also receive a message via its RF receiver and retransmit it via its RF transmitter to extend the range of lights beyond what is within the range of the initial unit that detected motion. In an alternate example, the control source may be one or more remote controls with a push button that is pressed to turn the lights on and a push button, that is pressed to turn the lights off with a unique identifier that can be set that may select the ceiling light or lights to control, and the like. When either button is pressed, a command may be transmitted by a remote control to the network to control the ceiling lights that receive it. The command may also be propagated through the network of ceiling lights via the RF transceiver in each ceiling light to control a portion of or the entire network of ceiling lights. It is to be appreciated that the ceiling lights may use any type of networking protocol (e.g. routing, flooding etc.) that may effectively distribute state information through the network. In embodiments, when an auto shutoff timer of the originating ceiling light times out, it may send an off command which is also propagated through the network of ceiling lights to shut one or more ceiling lights off. In embodiments, the triggering method may utilize any sensor described herein, the type of control of the ceiling lights may be any control mentioned herein, and the sending of signals from one ceiling light to another may be RF/IR, wired or wireless network (WIFI, ZIGBEE, X10 etc.) or wired with any electrical control mechanism between ceiling lights that can be defined. It is also to be appreciated that any standard or proprietary protocol (e.g. networking protocols such as IP, TCP, UDP, routing protocols etc. and physical layer protocols such as WIFI, Ethernet, ZIGBEE etc.) may be used to communicate between ceiling lights.

[0415] By way of an example, the ceiling lights may contain any of the functionality described herein, but also contain a ZIGBEE transceiver and the networking stack necessary to create a ZIGBEE mesh network of ceiling lights. In this case, the RF transmitter and receiver may be compliant to ZIGBEE standards. The networking stack allows for the creation of a mesh network that provides all of the routing and forwarding capabilities found in a typical ZIGBEE network. In addition, a ceiling light may act as a ZIGBEE access point allowing ZIGBEE compliant wireless sensors and devices to connect to the mesh network of ceiling lights. Thus a user may install lighting and a ZIGBEE network with the installation of the ZIGBEE capable ceiling lights. A ZIGBEE compliant adapter that can be plugged into a computer, for example into a USB port of a computer directly or by cable, may allow a software program running on the computer to program functionality into, control, or gather status from the network of ceiling lights. Intelligence designed into the ceiling light (microcontroller, microprocessor, integrated circuit etc.) and use of the ZIGBEE communication protocol between the ceiling lights and with the ZIGBEE adapter connected to the computer may allow software to communicate with the ceiling lights to implement the desired functionality. Thus, the intel-

light control may be distributed (e.g. each ceiling light may contain a microprocessor running specific software to implement functionality) or centralized (e.g. software running on the computer can contain most of the intelligence and can control the ceiling lights as required). It is to be appreciated that the ZIGBEE capable ceiling lights may be individually addressable such that the control may be from a single ceiling light up to the entire network of ceiling lights. In addition, if ZIGBEE compliant wireless devices or sensors are also installed, the software program may interface with those devices and provide additional functionality independent of the lighting installation. It is to be appreciated that any wireless lighting module or wireless light bulb may be designed to provide this functionality. In alternate embodiments, the ZIGBEE functionality may be replaced by WIFI, Z-Wave, BLUETOOTH, or any other network that may be useful in a deployment in addition to the lighting installation.

[0416] In other embodiments, the wireless lighting module may contain rechargeable batteries such that the module may be recharged by connecting the module to an AC power source such as plugging the module into a recharging base, plugging the module into an AC outlet directly, connecting the module to an AC outlet by cable, plugging a wall transformer to the wall then connecting a DC jack to the wireless lighting module, and the like. In some embodiments, the wireless lighting module may contain circuitry to convert the AC power source to DC and charge the batteries and may or may not power the light source while charging the batteries. In some embodiments, the wireless lighting module may be connected to a DC power source for recharging and as such would have circuitry to make use of the DC power source for recharging the batteries and may or may not power the light source while charging the batteries. By way of an example, an RF ceiling light containing rechargeable batteries may be mounted to the ceiling or wall. When the capacity of the rechargeable batteries dips below a level that the light output is no longer acceptable, a user may unscrew the RF ceiling light and connect it to a charging base. The charging base may be comprised of the circuitry necessary to charge the batteries to capacity as well as the electrical and mechanical configuration necessary to electrically and physically connect a ceiling light to the base. When battery charging is complete, the user may remove the ceiling light from the charging base and return it to the ceiling or wall. In another example, a motion spotlight containing rechargeable batteries that contains a 2.5 mm jack and accepts a DC input can be connected to a wall transformer with a 2.5 mm jack. The DC output of the wall transformer falls within the range of the DC input to charge the batteries. The motion spotlight may contain circuitry required to recharge the batteries and may or may not power the motion spotlight during the charging of the batteries.

[0417] In alternate embodiments, the wireless lighting module may have any type of connector on it that allows for charging by connection to a mating connector and that provides the AC or DC power source. In an alternate embodiment, the module may have a USB connector on it that allows for charging by connection to a USB port. In other alternate embodiments any form of wireless power mentioned herein may be used for recharging a wireless lighting module. By way of an example, one or more external thin film solar cells may be connected to the wireless lighting module by cable and provide a DC input to recharge the batteries. It is to be appreciated that any combination of charging approaches may be included in the same wireless lighting module.

[0418] In embodiments of a wireless lighting module, there may be a USB connector on the wireless lighting module. The USB connector may also be used as a communication interface to program the wireless lighting module. The wireless lighting module may attach to a computer via USB directly or over a USB cable to connect the module for programming. In other embodiments, different interface types on the module such as Ethernet, IEEE 1394 Fire Wire, Serial Port, or the like, may be used to connect to a computer directly or by cable to program the module. In another example, a programming adapter connected to the computer that the wireless lighting module can plug into or connect to electrically and mechanically in any known manner may serve as the interface to program the module. In other embodiments, an RF or IR adapter that can plug into a computer directly or via a cable using any of the interface types listed may send programming information to one or more wireless lighting modules containing an RF or IR receiver or transceiver to program the wireless lighting modules. In some embodiments, an RF or IR interface to the wireless lighting module may be provided by any intelligent device (e.g. remote control, keypad, PDA, custom circuit design, etc.) with the RF or IR interface, and the ability to communicate with the wireless lighting modules may be used to program the wireless lighting modules. A software program or other device that allows a user to set the state of the module based on timer or time of day, auto shut-off times, color temperature, light strength (glow levels, low light levels, dimming/fading functions), motion sensitivity and listening on times, light sensitivity, level of ambient light controlled by a photocell, energy usage control to control light output based on a desired amount of energy usage over time, network parameters (unique IDs, network IDs, multicast IDs, broadcast IDs, IP address, routing and forwarding information for the network, WIFI SSIDs, ZIGBEE PAN IDs and network IDs, X10 four bit house code, INSTEON address or the like), sensor parameters (detection thresholds for setting the state of the module, timer and time of day settings for when the sensor is active and the like), etc. may be used to connect to and program the state of the module. It is to be appreciated that the wireless lighting module may contain the intelligence necessary to implement the programmable functions.

[0419] In addition to controlling the lighting installation, the sensors and intelligence that are designed into wireless lighting modules and communication interface implemented in the wireless light modules may allow the wireless lighting modules installed to also perform functions in addition to lighting. This applies to any type of wireless lighting module mentioned herein. The embedded sensors and intelligence together with the communication interface may allow a single wireless lighting module to implement functionality beyond just lighting. Multiple wireless lighting modules may form a sensor network to add useful functions to a lighting installation where multiple wireless lighting modules may be individually controlled or work as a network to implement one or more functions in addition to lighting. A software program or intelligent device may allow a user to gather status from a sensor in the wireless lighting module or from intelligence designed into the wireless lighting module over the communication interface such as but not limited to temperature, ambient light levels, battery capacity levels, energy usage statistics, on and off time records, sensor detection data and statistics (motion detections per some unit of time, switch actuation information to generate an alarm, smoke detector

alarm signals etc.), network usage statistics, information that can be gathered from any sensor or intelligence built into the wireless lighting module, and the like. A software program or intelligent device may also receive a stream of data collected by a sensor of the wireless lighting module over the communication interface such as but not limited to audio from a microphone, a video stream from a camera, pictures from a digital camera, RFID tag read information (i.e. an RFID tag reader), etc. A software program or intelligent device may also control a device inside the wireless lighting module over the communication interface to implement any function such as but not limited to a speaker to make announcements or generate sound, a horn to generate alarms, enable a circuit to energize or de-energize a relay or other switch control, turn on or off a motor, etc.

[0420] An intelligent device (microcontroller, microprocessor, integrated circuit etc.) inside the wireless lighting module may also be reprogrammed in the field. By way of an example, a microcontroller may contain flash memory that can be reprogrammed. A new program may be transferred to the microcontroller, for example by an RF communication interface on the wireless lighting module. The new program may then be burned into flash memory by code running on the microcontroller and after programming the wireless lighting module may have a new or added function. In one embodiment, the RF with motion sensor stair light may contain a microcontroller that responds to RF and motion inputs. In embodiments, new microcode may be written for the RF with motion sensor stair light with an additional time of day clock that can be programmed to turn the light on or off at set times during the day. By programming the new microcode into flash memory on the RF with motion sensor stair light, the time of day function may be added.

[0421] In one use case, the design may be a battery powered, RF controlled ceiling light wireless lighting module that also contains a motion sensor. For instance, the ceiling lights may be installed in office space, such as in 50 different locations, in addition the lighting that is installed. Software running on a computer may allow a security guard to communicate with and receive status from the ceiling lights. When a ceiling light detects motion, it may send a message to the security guard's computer that motion has been detected and which module has detected the motion (i.e. the location where the motion is). In embodiments, the security guard may receive a message or an alarm that motion has been detected in one of 50 locations which may provide an indication of a security issue or that someone is not where they are supposed to be. In an alternate use case, the ceiling lights may record a statistic called "number of motion detections since last read". A software application may read and compile that statistic from each ceiling light and determine how to most efficiently use the lighting by time of day and usage profile. It may be used not only to control lighting but for occupancy studies in building management, used to record the flow of traffic past a certain point, control the entire lighting installation beyond just the ceiling lights, and the like. In one possible use, the sensor may not control lighting, but may be used for the information provided by the sensor in addition to the light that is used for illumination.

[0422] In another use case, the design may be a recessed fixture RFID reader wireless lighting module. In embodiments, they may be installed in office space, such as in 50 different locations, in addition the lighting that is installed. Employees and guests may be issued identification, such as

badges that are RFID tags or access cards that can be read by the RFID reader or the access card reader in the wireless lighting module. In addition, RFID tags may be attached to assets for operational efficiency and theft prevention. Software running on a computer may receive the reads of the identifications badges or asset tags and may provide an indication of current or last known location within the building with respect to the location of the RFID reader wireless lighting modules. For example, this may provide the building manager the ability to find, track or review the real time or historical movements of employees, guests or assets. In embodiments, this functionality may be used for safety, security, operational efficiency, etc.

[0423] In another use case, a wireless lighting module targeting a porch light application may have a speaker or alarm horn in it that allows announcements to be made (such as in the case of an intercom system which could be two way if the units had a microphone on them) or alarm sounds to be generated in certain emergency situations. In an alternate use case, the porch light may be designed with a microphone and speaker built in. In embodiments, a user may push a button on an intercom box inside of their house to talk or listen to a visitor through the porch light microphone and speaker.

[0424] It is to be appreciated that the programmability, ability to gather status or control the lighting, installation, and the like, may apply to wireless lighting modules, wireless light bulbs, wireless lighting fixtures, and the like, or a combination thereof. By way of an example, a lighting installation that includes RF controlled wireless light bulbs, RF ceiling lights, RF path lights and RF spotlights may be installed, and an intelligent lighting control software capable of communicating with all of the lighting components for programming, may gather status and/or control the entire mix of components in the lighting installation.

[0425] Alternate embodiments of the wireless lighting module may be designed with a housing that allows installation in a 2 or 4 pin plug-in fluorescent socket, or the like. In this embodiment, the housing may contain any of the features of a wireless lighting module, and in embodiments, designed with a 2 or 4 pin plug that allows it to be installed in a plug in fluorescent light fixture. The wireless lighting module may physically couple with the fixture to support the wireless lighting module, yet electrical current need not flow between the fixture and the wireless lighting module. In such a case, the wireless lighting module may contain one or more wireless power sources that provides power to the module. In embodiments, the wireless lighting module may contain one or more wireless control sources. In some embodiments, the wireless lighting module may replace a fluorescent light that is connected to a resistive, reactive, or electronic ballast in which case the wireless lighting module may also contain circuitry to take the output of the ballast and convert it to DC power suitable for the light source and wireless control. The wireless lighting module may also contain non-rechargeable or rechargeable batteries. In the case where the module contains rechargeable batteries it may contain the circuitry to charge the batteries. There may also be intelligence (microcontroller, microprocessor, integrated circuit etc.) inside the wireless lighting module such that it can be programmed to draw power from the AC input, from the rechargeable batteries, or both. In embodiments, the intelligence may use a real time clock and be programmed to use the AC input and charge the batteries during off peak billing times and use the battery power during on peak billing times such that there is an

overall cost savings in energy usage. The unit can be programmed for operation based on a Time of Use (TOU) price plan from the energy company. The rechargeable battery capacity may or may not be enough to power the light source for the entire duration of the on peak billing time. In such a case, the intelligence may be able to switch between battery power and AC input power based on a measurement of battery capacity level, power use from the embedded batteries and from the AC input or any other measurable parameter that allow for an optimization for cost or power consumption of the combined use of embedded batteries and AC input power.

[0426] In embodiments, the present invention may provide a power uninterruptable led light with sensor-based control for transferring to internal power in the event of an ac power disruption. As shown in FIG. 38, a system may provide an uninterruptable lighting source, comprising an uninterruptable lighting facility **3802** containing an LED lighting source **3804**, a remote control device **3808**, and a control facility **3810** for manipulating the light output of the LED lighting source, where the uninterruptable lighting facility provides the LED lighting source in response to a disruption of AC power **3812**. A rechargeable energy storage device **3814** integrated with the uninterruptable lighting facility may be capable of supplying power to the uninterruptable lighting facility independent of the AC power, where the recharging may be provided internal to the uninterruptable lighting facility at a time when the AC power may be available. The uninterruptable lighting facility may be disconnected from the AC power and used as a portable lighting device. The rechargeable energy storage device internal to the uninterruptable lighting facility may be a battery, fuel cell, super capacitor, and the like. The uninterruptable lighting facility may provide the lighting source based on information related to a switch setting sensing. The switch setting sensing may be through electrical impedance sensing. The switch setting sensing may be through a detection of AC power at a light switch. The detection may be provided through an RF transmitter embedded into the light switch that detects AC power prior to the switch and detects the state of the switch. The information may be transmitted to the uninterruptable lighting facility to switch over to the rechargeable energy storage device integrated with the uninterruptable lighting facility. The uninterruptable lighting facility may take the form of a light bulb that mounts into a standard lighting fixture. The uninterruptable lighting facility takes the form of a lighting fixture, a retrofit light bulb, a retrofit lighting fixture, a fluorescent tube, a fluorescent lamp, and the like. The remote control device may be an RF receiver for remote control signal input, IR receiver for remote control signal input, wireless communications receiver, a wireless communications transceiver, a wireless network interface device, and the like. The control facility may utilize a control input from an input device, internal timer, internal clock, internal program, and the like, to manipulate the light output of the LED lighting source. The control facility may select a power source for the light source from between AC power and the rechargeable energy storage device. The selection may be controlled by an internal timer or time of day clock, a light sensor sensing the level of ambient light, a motion sensor sensing motion, a stored command received from the remote control device, switches on the housing, detection of power sequencing, commands received over the power lines, and the like. The manipulating may be controlled by at least one of an internal timer or time of day clock, by a light sensor sensing the level

of ambient light, by a motion sensor sensing motion, by a command received from the remote, by switches on the housing, by detecting power sequencing, by commands over the power lines, and the like. The control facility controls when the rechargeable energy storage device may be charging. In addition there may be an input device. The input device may be a sensor device. The sensor device may sense IR, temperature, light, motion, acoustic, vibration, and the like. The sensor device may be an electrical power condition sense device. The input device may be an energy input device, including a solar cell, wind turbine, and the like. The manipulating may be switching on the light output, changing the illumination level of the light output, flashing the light output, changing the color content of the light output, and the like. The change to the illumination level of the output to a lower level may consume less power and provides longer battery life.

[0427] In embodiments, as shown in FIG. 39, a system may provide an uninterruptable lighting source, comprising an uninterruptable lighting facility **3902** containing an LED lighting source **3904**, and a control facility **3908** for manipulating the light output of the LED lighting source. The uninterruptable lighting facility may provide the LED lighting source in response to a disruption of AC power **3910**, and a replaceable battery **3912** integrated with the uninterruptable lighting facility may be capable of supplying power to the uninterruptable lighting facility independent of the AC power. The battery may be a rechargeable battery. The battery may be a non-rechargeable battery. There may be a low battery indication on the uninterruptable lighting source.

[0428] In embodiments, as shown in FIG. 40, a system may provide an uninterruptable lighting source, comprising an uninterruptable lighting facility **4002** containing an LED lighting source **4004**, an input device **4008**, an electrical switch condition sense device **4012**, and a control facility **4010** for manipulating the light output of the LED lighting source, where the uninterruptable lighting facility provides the LED lighting source in response to a disruption of AC power **4014**. A rechargeable energy storage device **4018** may be integrated with the uninterruptable lighting facility that may be capable of supplying power to the uninterruptable lighting facility independent of the AC power, where the recharging may be provided internal to the uninterruptable lighting facility at a time when the AC power may be available. The electrical switch condition sense device may determine the position of an electrical switch through electrical impedance sensing of the electrical switch.

[0429] In embodiments, as shown in FIG. 41, a system may provide an uninterruptable lighting source, comprising an uninterruptable lighting facility **4102** containing an LED lighting source **4104**, a sensor device **4108**, and a control facility **4110** for manipulating the light output of the LED lighting source, where the uninterruptable lighting facility provides the LED lighting source in response to a disruption of AC power **4112**. A replaceable battery **4114** may be integrated with the uninterruptable lighting facility that is capable of supplying power to the uninterruptable lighting facility independent of the AC power. The sensor device may sense IR, temperature, light, motion, acoustic, vibration, and the like.

[0430] In embodiments, as shown in FIG. 42, a system may provide an uninterruptable lighting source, comprising an uninterruptable lighting facility **4202** containing an LED lighting source **4204**, a sensor device **4208**, and a control facility **4210** for manipulating the light output of the LED

lighting source, where the uninterruptable lighting facility may provide the LED lighting source in response to a disruption of AC power 4212. A rechargeable energy storage device 4214 may be integrated with the uninterruptable lighting facility that is capable of supplying power to the uninterruptable lighting facility independent of the AC power, where the recharging may be provided internal to the uninterruptable lighting facility at a time when the AC power may be available. The sensor device may sense IR, temperature, light, motion, acoustic, vibration, and the like.

[0431] In embodiments, as shown in FIG. 43, a system may provide an uninterruptable lighting source, comprising an uninterruptable lighting facility 4302 containing an LED lighting source 4304 and a control facility 4308 for manipulating the light output of the LED lighting source, where the uninterruptable lighting facility may provide the LED lighting source in response to a disruption of AC power 4310. A rechargeable energy storage device 4312 may be integrated with the uninterruptable lighting facility that is capable of supplying power to the uninterruptable lighting facility independent of the AC power, where the recharging may be provided internal to the uninterruptable lighting facility at a time when the AC power may be available. The uninterruptable lighting facility may take the form of a light bulb that mounts into a standard lighting fixture, a fluorescent tube that mounts into a standard fluorescent lighting fixture, a fluorescent lamp that mounts into a standard lighting fixture or a standard fluorescent lighting fixture, and the like. The uninterruptable lighting facility may be disconnected from the AC power and used as a portable lighting device. The rechargeable energy storage device internal to the uninterruptable lighting facility may be a battery, fuel cell, super capacitor, and the like. In addition there may be an input device. The input device may be a sensor device. The sensor device may sense IR, temperature, light, motion, acoustic, vibration, and the like. The sensor device may be an electrical power condition sense device. The input device may be an energy input device, including a solar cell, wind turbine, and the like. The control facility may utilize a control input from an input device, internal timer, internal clock, internal program, and the like, to manipulate the light output of the LED lighting source. The manipulating may be controlled by at least one of an internal timer or time of day clock, a light sensor sensing the level of ambient light, a motion sensor sensing motion, a command received from the remote, switches on the housing, detecting power sequencing, commands over the power lines, and the like. The control facility may select a power source for the light source from between AC power and the rechargeable energy storage device. The selection may be controlled by an internal timer or time of day clock. A light sensor may sense the level of ambient light, motion sensor sensing motion, from the remote control device, by switches on the housing, by detection of power sequencing, by commands received over the power lines, and the like. The control facility may control when the rechargeable energy storage device may be charging. The manipulating may be switching on the light output, changing the illumination level of the light output, flashing the light output, changing the color content of the light output, and the like. The change to the illumination level of the output to a lower level may consume less power and provides longer battery life.

[0432] In embodiments, as shown in FIG. 44, the present invention may provide for an externally controllable LED light. A method may be provided for power management in a

lighting source, comprising providing an LED lighting facility 4402, where the LED lighting facility includes an LED lighting source 4404, an external control device 4408 for communicating between the LED light facility and an external control source 4418, an internal control facility 4410, an energy storage device 4414, and a connection to AC power 4412. Power usage may be shifted between the AC power and the energy storage device as controlled by the internal control facility and as a result of information received from the external control source. In addition there may be a remote control input device. The energy storage device may be a rechargeable battery, fuel cell, super capacitor, and the like. The internal control device may control a charging of the energy storage device from AC power. The external control source may communicate an external control signal to the external control device that provides light output, time-based, a trigger for a memory-based pre-programmed, a trigger for sensor-based preprogrammed, and the like, control of the LED lighting facility. The external control source may be generated by a utility company, a networked software application, and the like. The external control source may be communicated wirelessly from a network, through the power lines, through a wired network connection, and the like. The LED lighting facility may take the form of a light bulb that mounts into a standard lighting fixture, a lighting fixture, a lighting fixture that has no electrical connection to AC power, a fluorescent tube, a fluorescent lamp, and the like. The energy storage device may be capable of supplying the source of power for the LED lighting facility to provide power management, where power management may be due to AC power being interrupted, to improve energy efficiency, to provide cost savings, due to a need to reduce energy demand, and the like. The energy demand may be a peak energy demand, at predetermined times, at a time when new energy demand may be required at an energy provider, and the like. In addition there may be an internal control facility utilizing a control input from an input device, internal timer, internal clock, internal program, and the like, to manage the power usage. The management of power usage may be through selection of the power source, through control of when a power source may be charging, through the amount of load shared by the power sources, and the like.

[0433] In embodiments, as shown in FIG. 45, a method may provide for the power management in a lighting source, comprising providing an LED lighting facility 4502, where the LED lighting facility may include an LED lighting source 4504, an external control device 4508 for communicating between the LED light facility and an external control source 4520, an internal control facility 4510, an electrical switch condition sense device 4512, an energy storage device 4518, and a connection to AC power 4514. Power usage may be shifted between the AC power and the energy storage device as controlled by the internal control facility and as a result of information received from the external control source. The electrical switch condition sense device may determine the position of an electrical switch through electrical impedance sensing of the electrical switch. In addition there may be an internal control facility utilizing a control input from an input device, internal timer, internal clock, internal program, and the like, to manage the power usage. The management of power usage may be through selection of the power source, through control of when a power source may be charging, through the amount of load shared by the power sources, and

the like. The external control source may be generated by a utility company, a networked software application, and the like.

[0434] In embodiments, as shown in FIG. 46, a method may be provided for power management in a lighting source, comprising providing an LED lighting facility 4602, where the LED lighting facility includes an LED lighting source 4604, a sensor device 4608, an external control device 4610 for communicating between the LED light facility and an external control source 4620, an internal control facility 4612, an energy storage device 4618, and a connection to AC power 4614. Power usage may be shifted between the AC power and the energy storage device as controlled by the internal control facility and as a result of information received from the external control source. The sensor device may sense IR, temperature, light, motion, acoustic, vibration, and the like. In addition there may be an internal control facility utilizing a control input from an input device, internal timer, internal clock, internal program, and the like, to manage the power usage. The management of power usage may be through selection of the power source, through control of when a power source may be charging, through the amount of load shared by the power sources. The external control source may be generated by a utility company, a networked software application, and the like.

[0435] In embodiments, as shown in FIG. 47, a method may be provided for power management in a lighting source, comprising providing an LED lighting facility 4702, where the LED lighting facility includes an LED lighting source 4704, an input device 4708, an internal control facility 4710, an energy storage device 4714, and a connection to AC power 4712. Power usage may be shared between the AC power and the energy storage device as controlled by the internal control facility and as a result of a program resident with the internal control facility and an external control signal received by the input device. The input device may receive a program control input to alter the program. The sharing may provide power to the LED lighting facility from both the AC power and the energy storage device. The external control signal may be generated by a utility company, a networked software application, and the like. The external control signal may be communicated wirelessly from a network, through the power lines, through a wired network connection, and the like. In addition there may be the internal control facility utilizing a control input from an input device, internal timer, internal clock, internal program, and the like, to manage the power usage. The management of power usage may be through selection of the power source, through control of when a power source may be charging, through the amount of load shared by the power sources, and the like.

[0436] In embodiments, as shown in FIG. 48, a method may be provided for a method of power management in a lighting source, comprising providing an LED lighting facility 4802, where the LED lighting facility may include an LED lighting source 4804, a sensor device 4808, an external control device 4810 for communicating between the LED light facility and an external control source 4822, an internal control facility 4812, a network interface 4814, an energy storage device 4820, and a connection to AC power 4818. Power usage may be shifted between the AC power and the energy storage device as controlled by the internal control facility and as a result of information received from the external control source. The sensor device may sense IR, temperature, light, motion, acoustic, vibration, and the like. In addition there

may be an internal control facility utilizing a control input from an input device, internal timer, internal clock, internal program, and the like, to manage the power usage. The management of power usage may be through selection of the power source, through control of when a power source may be charging, through the amount of load shared by the power sources, and the like. The external control source may be generated by a utility company, a networked software application, and the like. The network interface may be a wireless network interface, wired network interface, interface to the Internet, local area network interface, and the like. The network may be embodied by a network of appliances, where at least one appliance in the network may be an LED lighting facility. The LED lighting facility may receive control and programming over the network. The LED lighting facility may receive data destined for another LED lighting facility or the external control device and may transmit data to route or forward that data through the network to the destination LED lighting facility or external control device.

[0437] In embodiments, the present invention may provide for a remote control wireless LED light bulb. As shown in FIG. 49, a lighting system may be provided, comprising a wireless LED lighting facility 4902 containing an LED lighting source 4904, a light sensor input device 4908, an internal rechargeable energy storage device 4912, and a control facility 4910 for manipulating the light output of the LED lighting source, where the wireless LED lighting facility may be powered by the internal rechargeable energy storage device. A housing 4914 may be provided for the wireless LED lighting facility that takes the form of a light bulb that mounts into a standard lighting fixture. The light sensor input device may provide a measurement of the amount of ambient light in an area. The wireless LED lighting facility may take the form of a light bulb that mounts into a standard lighting fixture, a fluorescent tube that mounts into a standard fluorescent lighting fixture, a fluorescent lamp that mounts into a standard lighting fixture or a standard fluorescent lighting fixture, and the like. The LED lighting facility may take the form of battery powered lighting fixture. The wireless LED lighting facility may be provided AC power to recharge the internal rechargeable energy storage device through a wired AC connection of the standard lighting fixture. The wireless LED lighting facility may be provided DC power to recharge the internal rechargeable energy storage device through a wired DC connection of the standard lighting fixture. The wireless LED lighting facility may be removed from the standard lighting fixture to become a portable wireless LED lighting facility. The input device may be an energy input device that provides energy to recharge the internal rechargeable energy storage device. The input device may be a solar cell, wind turbine, and the like. The control facility may utilize a control input from an input device, internal timer, internal clock, internal program, and the like, to manipulate the light output of the LED lighting source. The control input may be the reading of the ambient light level from the light sensor. The light output of the LED light source may be manipulated to maintain a constant value of light intensity based on the measurement of ambient light level plus light output level. The control facility may select a power source from between AC power and the rechargeable energy storage device. The control facility may control when the rechargeable energy storage device is charging. The control facility may control how power is shared between the rechargeable energy storage device and AC power. The manipulating may be switching on

the light output, changing the illumination level of the light output, flashing the light output, changing the color content of the light output, and the like. In addition there may be a remote control facility.

[0438] In embodiments, as shown in FIG. 50, a lighting system may be provided, comprising a wireless LED lighting facility 5002 containing an LED lighting source 5004, a sensor input 5008, a control input device 5010, an internal energy storage device 5014, and a programmable control facility 5012 for manipulating the light output of the LED lighting source. A housing 5018 may be provided for the wireless LED lighting facility that takes the form of a light bulb that mounts into a standard lighting fixture. The wireless LED lighting facility may take the form of a light bulb that mounts into a standard lighting fixture, a fluorescent tube that mounts into a standard fluorescent lighting fixture, a fluorescent lamp that mounts into a standard lighting fixture or a standard fluorescent lighting fixture, and the like. The programmable control facility may be programmed through the control input device. The input device may be a remote control, a wireless input device, a network input device, and the like. The programmable control facility may utilize the sensor input in programmable control. A programmability of the programmable control facility may be through the user. The programmable control facility may incorporate learned behavior as part of its operational control. The control input device may be a remote control input device. The sensor device may sense IR, temperature, light, motion, acoustic, vibration, and the like.

[0439] In embodiments, as shown in FIG. 51, a lighting system may be provided, comprising a wireless LED lighting facility 5102 containing an LED lighting source 5104, an impedance sensing device 5108, an control input device 5110, an internal energy storage device 5114, and a programmable control facility 5112 for manipulating the light output of the LED lighting source. A housing 5118 may be provided for the wireless LED lighting facility that takes the form of a light bulb that mounts into a standard lighting fixture. The wireless LED lighting facility may take the form of a light bulb that mounts into a standard lighting fixture, a fluorescent tube that mounts into a standard fluorescent lighting fixture, a fluorescent lamp that mounts into a standard lighting fixture or a standard fluorescent lighting fixture, and the like. The programmable control facility may be programmed through the control input device. The input device may be a remote control, a wireless input device, a network input device, and the like. The programmable control facility may utilize the sensor input. A programmability of the programmable control facility may be through the user. The programmable control facility may incorporate learned behavior as part of its operational control. The control input device may be a remote control input device. The sensor device may sense IR, temperature, light, motion, acoustic, vibration, and the like.

[0440] In embodiments, as shown in FIG. 52, a system may be provided for power management of a lighting facility 5202, comprising an LED lighting source 5204, a remote control input device 5208 for communicating between the lighting facility and a user, an input device 5210 for receiving information to aid in the power management of the lighting facility, a programmable control facility 5212 for manipulating the light output of the lighting source to decrease the energy usage of the lighting facility, and a source of power 5214 for the LED lighting facility, where the lighting facility may include the LED lighting source, the remote control

input device, the control facility, and the source of power. The programmable control facility may utilize a control input from an input device, internal timer, internal clock, internal program, learned behavior, and the like, to manipulate the light output of the LED lighting source. The decrease in energy usage may be due to an increase in energy efficiency. The decrease in energy usage may be due to a change in an energy usage profile of the LED lighting facility. The energy usage profile may be energy usage of the LED lighting facility over time. The change in an energy usage profile may be due to an input from the input device. The input may be a sensor input, a control signal from a user, a control signal from a network, a signal from a second LED lighting facility, and the like. The LED lighting facility may take the form of a light bulb that mounts into a standard lighting fixture. The LED lighting facility may take the form of a light bulb that mounts into a standard lighting fixture, a fluorescent tube that mounts into a standard fluorescent lighting fixture, a fluorescent lamp that mounts into a standard lighting fixture or a standard fluorescent lighting fixture, and the like. The LED lighting facility may take the form of a lighting fixture. The lighting fixture may have no electrical connection to AC power. The lighting facility may take the form of battery powered lighting fixture. The source of power may be AC power. The source of power may be DC power. The source of power may be a rechargeable energy storage device that may be internal to the LED lighting facility. The rechargeable energy storage device may be a battery, fuel cell, super capacitor, and the like. The source of power may be AC or DC power, where the AC or DC power provides charge to a rechargeable energy storage device integrated within the LED lighting facility. The rechargeable energy storage device may be capable of supplying the source of power for the LED lighting facility if AC power may be interrupted. The input device may be a control input device, including an RF receiver for remote control signal input, IR receiver for remote control signal input, wireless communications receiver, a wireless communications transceiver, a wireless network interface device, a sensor (such as an IR, temperature, motion, acoustic, vibration, sensor), a switch, an electrical power condition sense device, and the like. The input device may be an energy input device, including a solar cell, wind turbine, and the like.

[0441] In embodiments, as shown in FIG. 53, a lighting system may be provided, comprising a wireless LED lighting facility 5302 containing an LED lighting source 5304, an energy harvesting input device 5308, an internal rechargeable energy storage device 5314, a control input device 5310 and a control facility 5312 for manipulating the light output of the LED lighting source, where the wireless LED lighting facility may be powered by the internal rechargeable energy storage device which is recharged by the energy harvesting input device. A housing 5318 may be provided for the wireless LED lighting facility that takes the form of a light bulb that mounts into a standard lighting fixture. The wireless LED lighting facility may take the form of a light bulb that mounts into a standard lighting fixture, a fluorescent tube that mounts into a standard fluorescent lighting fixture, a fluorescent lamp that mounts into a standard lighting fixture or a standard fluorescent lighting fixture, and the like. The energy harvesting input device may be a solar cell, a device that capture radio frequency energy, a device that converts kinetic energy to electrical energy, a device that converts thermal energy to electrical energy, a device that converts wind to electrical energy, and the like. The wireless LED lighting facility may be pro-

vided power to recharge the internal rechargeable energy storage device through the energy harvesting input device. The wireless LED lighting facility may be removed from the standard lighting fixture to become a portable wireless LED lighting facility. The input device may be an energy input device that provides energy to recharge the internal rechargeable energy storage device. The input device may be a solar cell, wind turbine, and the like. The control input device may be a remote control input device. The control input device may be a sensor device that senses IR, temperature, light, motion, acoustic, vibration, and the like. The control facility may utilize a control input from an input device, internal timer, internal clock, internal program, and the like, to manipulate the light output of the LED lighting source. The control facility may select a power source from between energy harvesting power source and the rechargeable energy storage device. The control facility may controls when the rechargeable energy storage device is charging. The control facility may control how power may be shared between the rechargeable energy storage device and energy harvesting power source. The manipulating may be switching on the light output, changing the illumination level of the light output, flashing the light output, changing the color content of the light output, and the like. The control input device may be a remote control input device. The control input device may be a sensor device that senses IR, temperature, light, motion, acoustic, vibration, and the like.

[0442] In embodiments, as shown in FIG. 54, a system may be provided for power management of a lighting facility 5402, comprising an LED lighting source 5404, a remote control input device 5408 for communicating between the lighting facility and a user, an input device 5410 for receiving information to aid in the power management of the lighting facility, a programmable control facility 5412 for manipulating the light output of the lighting source to decrease the energy usage of the lighting facility, where the program of the programmable control facility utilizes learned behavior in executing control. A source of power 5414 may be provided for the LED lighting facility, where the lighting facility includes the LED lighting source, the remote control input device, the input device, the programmable control facility, and the source of power. The learned behavior may be behavior learned from inputs to at least one of the remote control input device and the input device. The learned behavior may be incorporated into a program uploaded to the programmable control facility. The programmable control facility utilizes a control input from an input device, internal timer, internal clock, internal program, learned behavior, and the like, to manipulate the light output of the LED lighting source. The decrease in energy usage may be due to an increase in energy efficiency. The decrease in energy usage may be due to a change in an energy usage profile of the LED lighting facility. The energy usage profile may be energy usage of the LED lighting facility over time. The change in an energy usage profile may be due to an input from the input device. The input may be a sensor input, a control signal from a user, a control signal from a network, a second LED lighting facility, and the like. The input device may be a control input device, including an RF receiver for remote control signal input, IR receiver for remote control signal input, wireless communications receiver, a wireless communications transceiver, a wireless network interface device, a sensor (e.g. IR, temperature, motion, acoustic, vibration sensor), a switch, an electrical power condition sense device, and the like.

[0443] In embodiments, as shown in FIG. 55, a lighting system may be provided, comprising a wireless LED lighting facility 5502 containing an LED lighting source 5504, a motion sensor 5508, an internal rechargeable energy storage device, an AC power connection, and a control facility, where the control facility 5510 may be programmable. A housing 5514 may be provided for the wireless LED lighting facility that takes the form of a light bulb that mounts into a standard lighting fixture, wherein the source of power 5512 to the wireless lighting facility may be determined through programming in the control facility. The light bulb may take the form of a standard light bulb, where a standard light bulb may be at least one of a standard size light bulb, such as a PAR30, PAR38, A19, R30, MR16, and the like. The programmability may be through switches integrated with the housing. The programmability may be stored in a program internal to the LED lighting facility. The programmability may enable the LED lighting facility to operate as a smart night light that may have multiple light intensity levels as determined by programming. The programmability may control the source of power. The source of power may be a shared power between the internal rechargeable energy storage device and the AC power. The determining may be automatic.

[0444] In embodiments, as shown in FIG. 56, a system may be provided for power management of a lighting facility 5602, comprising an LED lighting source 5604, a remote control input device 5608 for communicating between the lighting facility and a user, an input device 5610 for receiving information to aid in the power management of the lighting facility, a programmable control facility 5612 for manipulating the light output of the lighting source to decrease the cost of using the lighting facility, where the program of the programmable control facility utilizes learned behavior in executing control. A source of power 5614 may be provided for the LED lighting facility, where the lighting facility may include the LED lighting source, the remote control input device, the input device, the programmable control facility, and the source of power. The learned behavior may be behavior learned from inputs to at least one of the remote control input device and the input device. The learned behavior may be incorporated into a program uploaded to the programmable control facility.

[0445] In embodiments, the present invention may provide a wireless networked LED light with sensor-based control. As shown in FIG. 57, a system may be provided for coordinating the operation of a plurality of wireless lighting sources, comprising a first of a plurality of wireless LED lighting facilities 5702 containing an LED lighting source 5704, a sensor-based input device 5708, an external data communications interface 5710, a power source 5714, and a control facility 5712 for manipulating the light output of the LED lighting source, where the manipulating may be in part determined by data received from a second of the plurality of wireless LED lighting facilities 5720 through the external data communications interface. A housing 5718 may be provided for each of the plurality of wireless LED lighting facilities that takes the form of a light bulb that mounts into a standard lighting fixture. The wireless LED lighting facility may take the form of a light bulb that mounts into a standard lighting fixture, a fluorescent tube that mounts into a standard fluorescent lighting fixture, a fluorescent lamp that mounts into a standard lighting fixture or a standard fluorescent lighting fixture, and the like. The power source may be AC power through the standard lighting fixture. The wireless LED lighting facility

may take the form of a lighting fixture. The power source may be AC power hardwired to the lighting fixture. The wireless LED lighting facility may take the form of battery powered lighting fixture. The power source may be an internal energy storage device. The energy storage device may be a battery. The energy storage device may be a rechargeable energy storage device. The rechargeable energy storage device may be recharged by an AC power connection through the standard lighting fixture.

[0446] In embodiments, as shown in FIG. 58, a system may be provided for coordinating the operation of a plurality of wireless lighting sources, comprising a first of a plurality of wireless LED lighting facilities 5802 containing an LED lighting source 5804, a sensor-based input device 5808, an electric switch condition sense device 5820, an external data communications interface 5810, a power source 5814, and a control facility 5812 for manipulating the light output of the LED lighting source, where the manipulating may be in part determined by data received from a second of the plurality of LED lighting facilities 5822 through the external data communications interface. A housing 5818 may be provided for each of the plurality of wireless LED lighting facility that may take the form of a light bulb that mounts into a standard lighting fixture. The wireless LED lighting facility may take the form of a light bulb that mounts into a standard lighting fixture, a fluorescent tube that mounts into a standard fluorescent lighting fixture, a fluorescent lamp that mounts into a standard lighting fixture or a standard fluorescent lighting fixture, and the like. The wireless LED lighting facility may take the form of a lighting fixture. The power source may be AC power hardwired to the lighting fixture. The electrical switch condition sense device may determine the position of an electrical switch through electrical impedance sensing of the electrical switch. The control facility may manipulate the LED lighting source as a result of the electrical impedance sensing.

[0447] In embodiments, as shown in FIG. 59, a system may be provided for coordinating the operation of a plurality of wireless lighting sources, comprising a first of a plurality of networked wireless LED lighting facilities 5902 each containing an LED lighting source 5904, a sensor-based input device 5908, an external data communications interface 5910, a power source 5914, and a control facility 5912 for manipulating the light output of the LED lighting source, where the manipulating may be determined by a combination of environmental sensing input by the sensor-based input device, information received from a second of the plurality of networked wireless LED lighting facilities 5920, and data received from an outside control source. A housing 5918 may be provided for each of the plurality of wireless LED lighting facility that may take the form of a light bulb that mounts into a standard lighting fixture. The wireless LED lighting facility may take the form of a light bulb that mounts into a standard lighting fixture, a fluorescent tube that mounts into a standard fluorescent lighting fixture, a fluorescent lamp that mounts into a standard lighting fixture or a standard fluorescent lighting fixture, and the like. The power source may be AC power through the standard lighting fixture. The wireless LED lighting facility may take the form of a lighting fixture. The power source may be AC power hardwired to the lighting fixture. The wireless LED lighting facility may take the form of battery powered lighting fixture. The outside control source may be a network. The network may be embodied in a network of appliances, where at least one appliance may be a

lighting facility. The networked wireless LED lighting facility may receive control and programming over the network. The LED lighting facility may receive data destined for another networked wireless LED lighting facility or other device connected to the network and may transmit data to route or forward that data through the network to the destination LED lighting facility or other device. The networked wireless LED lighting facility may contain the next hop routing information in memory such that it may be able to propagate data through the network to the destination for the data even if it is not directly connected to the destination.

[0448] In embodiments, as shown in FIG. 60, an LED illumination system 6002 may be provided, comprising an LED light source 6004 mounted within a housing 6014, where the LED may be positioned to provide illumination from the housing, a transceiver 6010 associated with the housing such that the transceiver can receive and transmit wireless control signals from and to external sources 6018, a wireless power system 6012 for powering the LED illumination system, and a processor 6008, coupled to the transceiver, for interpreting received wireless control signals from a controller external source and transmitting wireless control signals for another LED illumination systems in accordance with the received wireless control signals.

[0449] In embodiments, as shown in FIG. 61, an LED illumination system 6102 may be provided, comprising an LED light source 6104 mounted within a housing 6114, where the LEDs are positioned to provide illumination from the housing; a receiver 6112 associated with the housing such that the receiver can receive wireless control signals from an external source 6122, where the control signals control a function of the LED illumination system. A wireless power system 6118 may be provided for powering the LED illumination system. A sensor 6108 may be provided for monitoring an environmental condition and controlling the function of the LED illumination system, where the wireless power system includes a circuit to periodically cycle 6120 the power of the receiver during a sleep period to increase the lifespan of the wireless power system. In addition there may be a processor for keeping a time of day, wherein the processor uses the time of day to regulate the power provided by the wireless power system. There may be a memory location for storing a value reflective of an LED illumination system auto shut-off period, wherein the value may be set by measuring a duration that a set control signal may be received by the receiver. There may be a memory location for storing a value reflective of an LED illumination system auto shut-off period, wherein the value may be set by measuring available power from the wireless power system. There may be a processor, coupled to the receiver, for interpreting the wireless control signals from the external source for a channel indication, wherein if the channel indication indicates that the wireless control signals are intended for the LED illumination system, the processor will control the LED illumination system in accordance with the wireless control signals. There may be a processor, coupled to the transceiver, for interpreting received wireless control signals from a controller external source and transmitting wireless control signals for another LED illumination systems in accordance with the received wireless control signals.

[0450] In embodiments, the present invention may provide a centralized power outage bridging to a networked lighting system. As shown in FIG. 62, a system may be provided for power outage management for a plurality of lighting sources, comprising at least one of a plurality of lighting facilities

6202 containing an LED lighting source **6204**, a sensor input device **6208**, a power outage input device **6212**, a power source **6214**, and a control facility **6210** for manipulating the light output of the LED lighting source, where the lighting facility provides light in response to a signal received by the power outage input device indicating a power outage and an environmental input from the sensor input device. The signal may be transmitted from a centralized controller. The centralized controller may be a power outage module monitoring power at some point in power distribution to detect a disruption in power. The power outage module may plug into an AC outlet and monitor power at the outlet to determine if there is a disruption in AC power. The power outage module may communicate wirelessly to one or more lighting facilities. The one or more lighting facilities may contain a wireless receiver to receive commands from the power outage module. The centralized controller may be running a software control program. The signal may be received from a web-based source. The web-based source may be on a local network, on the internet, and the like. The power source may be an energy storage device integrated with each of the lighting facilities that may be capable of supplying power to the lighting facility independent of the AC power, and where the recharging may be provided internal to the lighting facility at a time when the AC power may be available. The lighting facility may be disconnected from the AC power and used as a portable lighting device. The energy storage device may be a rechargeable energy storage device. The rechargeable energy storage device internal to the lighting facility may be a battery, fuel cell, super capacitor, and the like. The lighting facility may take the form of a light bulb that mounts into a standard lighting fixture, of a lighting fixture, of a retrofit light bulb, of a retrofit lighting fixture, of battery powered lighting fixture, and the like. The sensor may sense IR, temperature, light, motion, acoustic, vibration, and the like. The manipulating may be switching on the light output, changing the illumination level of the light output, flashing the light output, changing the color content of the light output, and the like.

[0451] In embodiments, as shown in FIG. 63, a system may be provided for power outage management for a plurality of lighting sources, comprising at least one of a plurality of lighting facilities **6302** containing an LED lighting source **6304**, an electric switch condition sense device **6308**, a power outage input device **6312**, a power source **6314**, and a control facility **6310** for manipulating the light output of the LED lighting source, where the lighting facility provides light in response to a signal received by the power outage input device indicating a power outage and an input from the electric switch condition sense device. The electrical switch condition sense device may determine the position of an electrical switch through electrical impedance sensing of the electrical switch. The control facility may manipulate the LED lighting source as a result of the electrical impedance sensing. There may be an electrical switch condition sensing capability in the power outage module to determine the position of an electrical switch through electrical impedance sensing of the circuit it is connected to. The power outage module may manipulate the LED lighting source as a result of the electrical impedance sensing.

[0452] In embodiments, as shown in FIG. 64, a system may be provided for power outage management for a plurality of lighting sources, comprising at least one of a plurality of lighting facilities **6402** containing an LED lighting source **6404**, a sensor input device **6408**, a connection to an external

emergency lighting system **6414**, a power source **6412**, and a control facility **6410** for manipulating the light output of the LED lighting source, where the lighting facility provides light in response to a signal received by the power external emergency lighting system indicating a power outage and an environmental input from the sensor input device. The signal may be transmitted from a centralized controller. The centralized controller may be an emergency lighting system module monitoring a command from the emergency lighting system to switchover to emergency power. The emergency lighting system module may communicate wirelessly to one or more lighting facilities. The one or more lighting facilities may contain a wireless receiver to receive commands from the emergency lighting system module.

[0453] In embodiments, the present invention may provide a sensor-based wirelessly controlled LED light bulb. As shown in FIG. 65, an LED illumination system **6502** may be provided, comprising an LED light source **6504** mounted within a housing **6512**, where the LEDs are positioned to provide illumination from the housing, a receiver **6510** associated with the housing such that the receiver can receive wireless control signals from an external source **6514**, where the control signals control a function of the LED illumination system. A sensor **6508** may be provided for monitoring an environmental condition and controlling the function of the LED illumination system. In addition there may be a processor, coupled to the receiver, for interpreting the wireless control signals from the external source for a channel indication, where if the channel indication indicates that the wireless control signals are intended for the LED illumination system, the processor will control the LED illumination system in accordance with the wireless control signals. There may be a remote sensor transmitter that may transmit sensor information to the illumination system. The remote sensor may sense IR, temperature, light, motion, acoustic, vibration, and the like. The sensor may be a motion sensor that transmits to the illumination system when motion may be detected. The sensor may be a light sensor that transmits the detected light level to the illumination system. The light output of the LED light source may be manipulated to maintain a constant value of light intensity based on the measurement of ambient light level plus light output level. The light sensor may be used to provide a regular update of ambient light level to manipulate the light output. The light sensor may be used to calibrate the light output of the LED light source where the remote light sensor does not have to be present to maintain the calibrated light output level. The LED illumination system may receive power via a standard light fixture. The control facility may control the amount of power drawn from the standard light fixture.

[0454] In embodiments, as shown in FIG. 66, a lighting system may be provided, comprising a wireless LED lighting facility **6602** containing an LED lighting source **6604**, a light sensor input device **6608**, and a control facility **6610** for manipulating the light output of the LED lighting source, where the wireless LED lighting facility receives power via a standard light fixture. A housing **6612** may be provided for the wireless LED lighting facility that takes the form of a light bulb that mounts into a standard lighting fixture **6614**. The light sensor input device may provide a measurement of the amount of ambient light in an area. The light bulb may take the form of a standard light bulb, where a standard light bulb may be at least one of a standard size light bulb, such as a PAR30, PAR38, A19, R30, MR16, and the like. The light bulb

may take the form of a non standard light bulb, where a non standard light bulb may be any size or shape of bulb for custom application. The light bulb may take the form of a fluorescent tube, a fluorescent lamp, and the like. The control facility may utilize a control input from an input device, internal timer, internal clock, internal program, and the like, to manipulate the light output of the LED lighting source. The control input may be the reading of the ambient light level from the light sensor. The light output of the LED light source may be manipulated to maintain a constant value of light intensity based on the measurement of ambient light level plus light output level. The control facility may control the amount of power drawn from the standard light fixture. The manipulating may be switching on the light output, changing the illumination level of the light output, flashing the light output, changing the color content of the light output, and the like.

[0455] In embodiments, as shown in FIG. 67, a lighting system may be provided, comprising a wireless LED lighting facility 6702 containing an LED lighting source 6704, and a control facility 6708, where the control facility may be programmable. A housing 6712 may be provided for the wireless LED lighting facility that takes the form of a light bulb that mounts into a standard lighting fixture 6714. In addition, there may be an input device. The input device may be a sensor device. The sensor device may sense IR, temperature, light, motion, acoustic, vibration, and the like. The input device may be a switch, pushbutton, dial, a knob on the housing, and the like. The programmability may be through switches integrated with the housing. The programmability may be stored in a program internal to the LED lighting facility. The light bulb may take the form of a standard light bulb, where a standard light bulb may be at least one of a standard size light bulb, such as a PAR30, PAR38, A19, R30, MR16, and the like. The light bulb may take the form of a non standard light bulb, where a non standard light bulb may be any size or shape of bulb for custom application. The light bulb may take the form of a fluorescent tube, a fluorescent lamp, and the like. The lighting system may receive power via a standard light fixture. The control facility may have an internal timer, time of day clock, and the like. The schedule of manipulating the light output may be stored in the internal program. The control facility may take input from a light sensor input device sensing the level of ambient light. The light output of the LED light source may be manipulated to maintain a constant value of light intensity based on the measurement of ambient light level plus light output level. The manipulating of the light output may be configured by switches on the housing. The control facility may control the amount of power drawn from the standard light fixture. The control facility may manipulate the light output of the LED lighting source where the manipulating may be switching on the light output, changing the illumination level of the light output, flashing the light output, changing the color content of the light output, and the like.

[0456] The methods and systems described herein may be deployed in part or in whole through a machine that executes computer software, program codes, and/or instructions on a processor. The present invention may be implemented as a method on the machine, as a system or apparatus as part of or in relation to the machine, or as a computer program product embodied in a computer readable medium executing on one or more of the machines. The processor may be part of a server, client, network infrastructure, mobile computing plat-

form, stationary computing platform, or other computing platform. A processor may be any kind of computational or processing device capable of executing program instructions, codes, binary instructions and the like. The processor may be or include a signal processor, digital processor, embedded processor, microprocessor or any variant such as a co-processor (math co-processor, graphic co-processor, communication co-processor and the like) and the like that may directly or indirectly facilitate execution of program code or program instructions stored thereon. In addition, the processor may enable execution of multiple programs, threads, and codes. The threads may be executed simultaneously to enhance the performance of the processor and to facilitate simultaneous operations of the application. By way of implementation, methods, program codes, program instructions and the like described herein may be implemented in one or more thread. The thread may spawn other threads that may have assigned priorities associated with them; the processor may execute these threads based on priority or any other order based on instructions provided in the program code. The processor may include memory that stores methods, codes, instructions and programs as described herein and elsewhere. The processor may access a storage medium through an interface that may store methods, codes, and instructions as described herein and elsewhere. The storage medium associated with the processor for storing methods, programs, codes, program instructions or other type of instructions capable of being executed by the computing or processing device may include but may not be limited to one or more of a CD-ROM, DVD, memory, hard disk, flash drive, RAM, ROM, cache and the like.

[0457] A processor may include one or more cores that may enhance speed and performance of a multiprocessor. In embodiments, the process may be a dual core processor, quad core processors, other chip-level multiprocessor and the like that combine two or more independent cores (called a die).

[0458] The methods and systems described herein may be deployed in part or in whole through a machine that executes computer software on a server, client, firewall, gateway, hub, router, or other such computer and/or networking hardware. The software program may be associated with a server that may include a file server, print server, domain server, internet server, intranet server and other variants such as secondary server, host server, distributed server and the like. The server may include one or more of memories, processors, computer readable media, storage media, ports (physical and virtual), communication devices, and interfaces capable of accessing other servers, clients, machines, and devices through a wired or a wireless medium, and the like. The methods, programs or codes as described herein and elsewhere may be executed by the server. In addition, other devices required for execution of methods as described in this application may be considered as a part of the infrastructure associated with the server.

[0459] The server may provide an interface to other devices including, without limitation, clients, other servers, printers, database servers, print servers, file servers, communication servers, distributed servers and the like. Additionally, this coupling and/or connection may facilitate remote execution of program across the network. The networking of some or all of these devices may facilitate parallel processing of a program or method at one or more location without deviating from the scope of the invention. In addition, any of the devices attached to the server through an interface may include at least one storage medium capable of storing methods, pro-

grams, code and/or instructions. A central repository may provide program instructions to be executed on different devices. In this implementation, the remote repository may act as a storage medium for program code, instructions, and programs.

[0460] The software program may be associated with a client that may include a file client, print client, domain client, internet client, intranet client and other variants such as secondary client, host client, distributed client and the like. The client may include one or more of memories, processors, computer readable media, storage media, ports (physical and virtual), communication devices, and interfaces capable of accessing other clients, servers, machines, and devices through a wired or a wireless medium, and the like. The methods, programs or codes as described herein and elsewhere may be executed by the client. In addition, other devices required for execution of methods as described in this application may be considered as a part of the infrastructure associated with the client.

[0461] The client may provide an interface to other devices including, without limitation, servers, other clients, printers, database servers, print servers, file servers, communication servers, distributed servers and the like. Additionally, this coupling and/or connection may facilitate remote execution of program across the network. The networking of some or all of these devices may facilitate parallel processing of a program or method at one or more location without deviating from the scope of the invention. In addition, any of the devices attached to the client through an interface may include at least one storage medium capable of storing methods, programs, applications, code and/or instructions. A central repository may provide program instructions to be executed on different devices. In this implementation, the remote repository may act as a storage medium for program code, instructions, and programs.

[0462] The methods and systems described herein may be deployed in part or in whole through network infrastructures. The network infrastructure may include elements such as computing devices, servers, routers, hubs, firewalls, clients, personal computers, communication devices, routing devices and other active and passive devices, modules and/or components as known in the art. The computing and/or non-computing device(s) associated with the network infrastructure may include, apart from other components, a storage medium such as flash memory, buffer, stack, RAM, ROM and the like. The processes, methods, program codes, instructions described herein and elsewhere may be executed by one or more of the network infrastructural elements.

[0463] The methods, program codes, and instructions described herein and elsewhere may be implemented on a cellular network having multiple cells. The cellular network may either be frequency division multiple access (FDMA) network or code division multiple access (CDMA) network. The cellular network may include mobile devices, cell sites, base stations, repeaters, antennas, towers, and the like. The cell network may be a GSM, GPRS, 3G, EVDO, mesh, or other networks types.

[0464] The methods, programs codes, and instructions described herein and elsewhere may be implemented on or through mobile devices. The mobile devices may include navigation devices, cell phones, mobile phones, mobile personal digital assistants, laptops, palmtops, netbooks, pagers, electronic books readers, music players and the like. These devices may include, apart from other components, a storage

medium such as a flash memory, buffer, RAM, ROM and one or more computing devices. The computing devices associated with mobile devices may be enabled to execute program codes, methods, and instructions stored thereon. Alternatively, the mobile devices may be configured to execute instructions in collaboration with other devices. The mobile devices may communicate with base stations interfaced with servers and configured to execute program codes. The mobile devices may communicate on a peer to peer network, mesh network, or other communications network. The program code may be stored on the storage medium associated with the server and executed by a computing device embedded within the server. The base station may include a computing device and a storage medium. The storage device may store program codes and instructions executed by the computing devices associated with the base station.

[0465] The computer software, program codes, and/or instructions may be stored and/or accessed on machine readable media that may include: computer components, devices, and recording media that retain digital data used for computing for some interval of time; semiconductor storage known as random access memory (RAM); mass storage typically for more permanent storage, such as optical discs, forms of magnetic storage like hard disks, tapes, drums, cards and other types; processor registers, cache memory, volatile memory, non-volatile memory; optical storage such as CD, DVD; removable media such as flash memory (e.g. USB sticks or keys), floppy disks, magnetic tape, paper tape, punch cards, standalone RAM disks, ZIP drives, removable mass storage, off-line, and the like; other computer memory such as dynamic memory, static memory, read/write storage, mutable storage, read only, random access, sequential access, location addressable, file addressable, content addressable, network attached storage, storage area network, bar codes, magnetic ink, and the like.

[0466] The methods and systems described herein may transform physical and/or intangible items from one state to another. The methods and systems described herein may also transform data representing physical and/or intangible items from one state to another.

[0467] The elements described and depicted herein, including in flow charts and block diagrams throughout the figures, imply logical boundaries between the elements. However, according to software or hardware engineering practices, the depicted elements and the functions thereof may be implemented on machines through computer executable media having a processor capable of executing program instructions stored thereon as a monolithic software structure, as standalone software modules, or as modules that employ external routines, code, services, and so forth, or any combination of these, and all such implementations may be within the scope of the present disclosure. Examples of such machines may include, but may not be limited to, personal digital assistants, laptops, personal computers, mobile phones, other handheld computing devices, medical equipment, wired or wireless communication devices, transducers, chips, calculators, satellites, tablet PCs, electronic books, gadgets, electronic devices, devices having artificial intelligence, computing devices, networking equipments, servers, routers and the like. Furthermore, the elements depicted in the flow chart and block diagrams or any other logical component may be implemented on a machine capable of executing program instructions. Thus, while the foregoing drawings and descriptions set forth functional aspects of the disclosed systems, no particu-

lar arrangement of software for implementing these functional aspects should be inferred from these descriptions unless explicitly stated or otherwise clear from the context. Similarly, it will be appreciated that the various steps identified and described above may be varied, and that the order of steps may be adapted to particular applications of the techniques disclosed herein. All such variations and modifications are intended to fall within the scope of this disclosure. As such, the depiction and/or description of an order for various steps should not be understood to require a particular order of execution for those steps, unless required by a particular application, or explicitly stated or otherwise clear from the context.

[0468] The methods and/or processes described above, and steps thereof, may be realized in hardware, software or any combination of hardware and software suitable for a particular application. The hardware may include a general purpose computer and/or dedicated computing device or specific computing device or particular aspect or component of a specific computing device. The processes may be realized in one or more microprocessors, microcontrollers, embedded microcontrollers, programmable digital signal processors or other programmable device, along with internal and/or external memory. The processes may also, or instead, be embodied in an application specific integrated circuit, a programmable gate array, programmable array logic, or any other device or combination of devices that may be configured to process electronic signals. It will further be appreciated that one or more of the processes may be realized as a computer executable code capable of being executed on a machine readable medium.

[0469] The computer executable code may be created using a structured programming language such as C, an object oriented programming language such as C++, or any other high-level or low-level programming language (including assembly languages, hardware description languages, and database programming languages and technologies) that may be stored, compiled or interpreted to run on one of the above devices, as well as heterogeneous combinations of processors, processor architectures, or combinations of different hardware and software, or any other machine capable of executing program instructions.

[0470] Thus, in one aspect, each method described above and combinations thereof may be embodied in computer executable code that, when executing on one or more computing devices, performs the steps thereof. In another aspect, the methods may be embodied in systems that perform the steps thereof, and may be distributed across devices in a number of ways, or all of the functionality may be integrated into a dedicated, standalone device or other hardware. In another aspect, the means for performing the steps associated with the processes described above may include any of the hardware and/or software described above. All such permutations and combinations are intended to fall within the scope of the present disclosure.

[0471] While the invention has been disclosed in connection with the preferred embodiments shown and described in detail, various modifications and improvements thereon will become readily apparent to those skilled in the art. Accordingly, the spirit and scope of the present invention is not to be limited by the foregoing examples, but is to be understood in the broadest sense allowable by law.

[0472] All documents referenced herein are hereby incorporated by reference.

1.-20. (canceled)

21. A power module for providing power to an electrical circuit that includes at least one light source, comprising:
 an alternating current (AC) power input configured to receive AC power for supplying to the electrical circuit and powering the at least one light source;
 a receiver configured to receive a power outage indication signal from a power outage detection unit located remotely from the power module;
 a battery;
 an inverter circuit configured to convert direct current (DC) power from the battery to AC power for powering the at least one light source; and
 a controller configured to:
 selectively control application of AC power from the AC power input to the electrical circuit; and
 selectively control application of AC power from the inverter circuit to the electrical circuit based on the power outage indication signal.

22. The power module of claim **21**, wherein the controller is configured to selectively control at least one of the application of AC power from the AC power input to the electrical circuit or the application of AC power from the inverter circuit to the electrical circuit based on input that is received via a user interface on the power outage detection unit and transmitted to the receiver.

23. The power module of claim **21**, wherein the receiver includes a radio frequency (RF) receiver, and the power outage indication signal includes a loss of AC power signal wirelessly transmitted to the receiver.

24. The power module of claim **21**, wherein the controller is further configured to selectively control application of AC power from the inverter circuit and the AC power input such that either all power supplied to the electrical circuit originates from the battery or a part of the power supplied to the electrical circuit originates from the battery and a part of the power supplied to the electrical circuit originates from the AC power from the AC power input.

25. The power module of claim **21**, wherein the inverter circuit further includes a grid-tie inverter in electrical communication with both the battery and the AC power input.

26. The power module of claim **21**, wherein the AC power input is in electrical communication with and receives the AC power from a connector configured to connect with an electric wall outlet.

27. The power module of claim **21**, wherein the controller is configured to selectively control the application of AC power from the inverter circuit by selectively controlling application of DC power to the inverter circuit.

28. The power module of claim **21**, wherein the battery includes a rechargeable battery.

29. A power adapter, comprising:

an Edison socket interface configured to supply alternating current (AC) power to a light source connected to the Edison socket interface;
 an Edison base interface configured to receive AC power for providing to at least one of an electrical circuit in electrical communication with at least one light source or the Edison socket interface;
 a battery;
 a receiver configured to receive an AC power loss signal provided by a power outage detection unit located remotely from the power adapter;

an inverter circuit configured to convert direct current (DC) power from the battery to AC power for powering one or more of the at least one light source or the light source connected to the Edison socket interface; and a controller configured to:

- selectively control application of AC power from the Edison base interface to one or more of the at least one light source or the Edison socket interface; and
- selectively control application of AC power from the inverter circuit to one or more of the at least one light source or the Edison socket interface based on the AC power loss signal.

30. The power adapter of claim **29**, wherein the controller is configured to selectively control the application of AC power from the inverter circuit by selectively controlling application of DC power to the inverter circuit.

31. The power adapter of claim **30**, wherein the power outage detection unit is configured to generate the AC power loss signal by monitoring power supplied by a wall outlet.

32. The power adapter of claim **31**, wherein the power outage detection unit is configured to be removably inserted into the wall outlet.

33. The power adapter of claim **29**, wherein the controller is configured to selectively control at least one of the application of AC power from the Edison base interface to one or more of the at least one light source or the Edison socket interface or the application of AC power from the inverter circuit to one or more of the at least one light source or the Edison socket interface based on input that is received via a user interface on the power outage detection unit and transmitted to the receiver.

34. The power adapter of claim **29**, wherein the receiver includes a radio frequency (RF) receiver, and the AC power loss signal is wirelessly transmitted to the receiver.

35. The power adapter of claim **29**, wherein the controller is further configured to selectively control application of AC power from the inverter circuit and the Edison base interface such that either all power supplied to the at least one light source and the light source connected to the Edison socket interface originates from the battery or a part of the power supplied to the at least one light source and the light source connected to the Edison socket interface originates from the battery and a part of the power supplied to the at least one light source and the light source connected to the Edison socket interface originates from the AC power from the Edison base interface.

36. The power adapter of claim **29**, wherein the at least one light source connected to the Edison socket interface includes

at least one of an incandescent light source, a fluorescent light source or an LED light source.

37. The power adapter of claim **29**, wherein the battery includes a rechargeable battery.

38. An emergency lighting system configured to provide power to at least one light source, the emergency lighting system comprising:

- a power outage detection unit including an interface configured for removable insertion into a wall outlet, the power outage detection unit being configured to monitor the presence of AC power at the wall outlet and to generate a power outage indication signal in the absence of AC power at the wall outlet; and
- a power module including:
 - an alternating current (AC) power input configured to receive AC power for supplying to an electrical circuit and powering the at least one light source;
 - a battery;
 - an inverter circuit configured to convert direct current (DC) power from the battery to AC power for powering the at least one light source; and
 - a controller configured to:
 - selectively control application of AC power from the AC power input to the electrical circuit; and
 - selectively control application of AC power from the inverter circuit to the electrical circuit based on the power outage indication signal.

39. The emergency lighting system of claim **38**, wherein the AC power loss signal is wirelessly transmitted to a radio frequency (RF) receiver of the power module.

40. The emergency lighting system of claim **38**, wherein the controller is configured to selectively control the application of AC power from the inverter circuit by selectively controlling application of DC power to the inverter circuit.

41. The emergency lighting system of claim **38**, further comprising a user interface on the power outage detection unit, wherein the controller of the power module is configured to selectively control at least one of the application of AC power from the AC power input to the electrical circuit or the application of AC power from the inverter circuit to the electrical circuit based on input that is received via the user interface.

* * * * *