

(19)



Europäisches Patentamt
European Patent Office
Office européen des brevets



(11)

EP 0 856 360 A2

(12)

EUROPEAN PATENT APPLICATION

(43) Date of publication:
05.08.1998 Bulletin 1998/32

(51) Int. Cl.⁶: B04B 1/20

(21) Application number: 97121247.7

(22) Date of filing: 03.12.1997

(84) Designated Contracting States:
AT BE CH DE DK ES FI FR GB GR IE IT LI LU MC
NL PT SE
Designated Extension States:
AL LT LV MK RO SI

(74) Representative:
Di Francesco, Gianni et al
Ing. Barzanò & Zanardo Milano S.p.A.
Corso Vittorio Emanuele II, 61
10128 Torino (IT)

(30) Priority: 05.12.1996 IT TO960990

Remarks:

A request for correction of the description, claims and abstract has been filed pursuant to Rule 88 EPC. A decision on the request will be taken during the proceedings before the Examining Division (Guidelines for Examination in the EPO, A-V, 3.).

(71) Applicant:
Cornello Centrifughe S.r.l.
70123 Bari (IT)

(72) Inventor: Cornello, Alessandro
70123 Bari (IT)

(54) **An inner scroll for an olive oil centrifugal separator**

(57) A rotating inner scroll (10) for a centrifugal separator with a horizontal axis for separating the liquid and solid phases from a past of crushed olives, comprises an elongated central hub (14) of substantially tubular shape and an outer drum of substantially truncated cone shape. The inner scroll comprises one or more

baffles (20) oriented in an axial planes. The baffles are radially extending between the tubular hub (14) and the drum so as to form a barrier encompassing at least the boundary zone (A) between the oil and the water being separated by centrifugation.

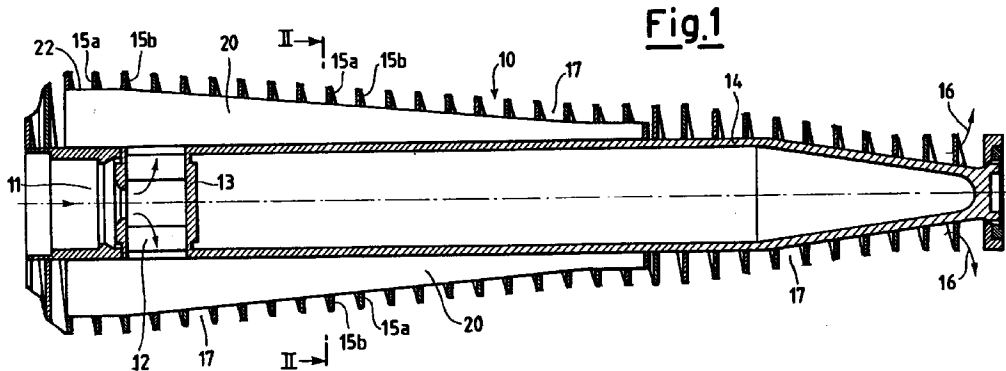

EP 0 856 360 A2

Description

Field of the invention

The present invention falls within the field of machines for separating olive oil. More particularly, the invention relates to an inner rotating scroll for a centrifugal separator with a horizontal axis of rotation.

Background of the invention

In the food industry it is well known to use centrifugal separators for extracting olive oil. These separators exploit the centrifugal separation principle to separate a composite mixture consisting of a paste of crushed olives into its components (oil, water, solid fraction). The separated components are then collected at distinct zones of the separator.

Conventional centrifugal separators comprise a central supply tube in which a crushed olive paste is let in. Around the central supply tube there is mounted a rotating drum of substantially truncated cone shape, formed by the union of adjacent cylindrical and truncated cone drum portions.

Rotation of the scroll and the drum fast thereto causes the components to separate from each other in accordance with their specific gravity. The solid phase, being the heaviest, forms a radially outer layer on the peripheral wall of the drum. The liquids, oil and water, stratify radially in cylindrical coaxial layers in the radially innermost zone near the scroll. Specifically, beginning from the outside, the olive husk layer forms in the radially outer part of the drum, followed by an intermediate water layer and a radially inner oil layer. The various separated phases are expelled from zones of the separator drum at axially different locations. The solid olive husk phase is expelled by the rotating inner scroll from one end of the separator, the liquid phases at distinct ports at the axially opposite side.

In scrolls of conventional design, the centrifugation creates a rotational speed gradient between the layers of different phases. Owing to friction, a rotational speed gradient is also present within a same layer, as the particles near a layer of another adjacent phase tend to be driven by this and therefore rotate at a different rotational speed with respect to the average angular speed of the particles belonging to a same layer.

Owing to such a difference of speed there is no sharp distinction between two radially adjacent layers. Instead, at the boundary zone between two layers of different phases heterogeneous layers are formed wherein the different phases remain mixed.

As apparent, this phenomenon adversely affects production efficiency and results in an increase of costs.

Summary of the invention

Accordingly, it is a primary object of the present

invention to provide an improved inner scroll capable of overcoming the above mentioned disadvantages and limitations of the prior art.

Toward the attainment of this and additional objects and advantages, the present invention, briefly summarised, provides a rotating inner scroll for a centrifugal separator with a horizontal axis for separating the liquid and solid phases from a past of crushed olives, the scroll comprising an elongated central hub of substantially tubular shape and an outer drum of substantially truncated cone shape, characterised by comprising at least one baffle oriented in an axial plane, said at least one baffle radially extending between the tubular hub and the drum so as to form at least one barrier encompassing at least the boundary zone between the oil and the water being separated by centrifugation.

Preferably, said at least one barrier encompasses both the boundary zones between the liquid and solid phases separated by centrifugation.

Still preferably, the inner scroll comprises a plurality of axial baffles oriented according to axial planes angularly spaced around the tubular hub and forming a plurality of said barriers.

Brief description of the drawings

In order that the present invention may be well understood there will now be described a preferred embodiment thereof, given by way of example, reference being made to the accompanying drawings, in which:

- FIG. 1 is an axial sectional view of a first embodiment of an inner scroll for a centrifugal separator in accordance with the present invention;
- FIG. 2 is a radial cross sectional view taken along the line II-II of FIG. 1; and
- FIGS. 3, 4 and 5 are axial cross sectional views, to a smaller scale, of three further embodiments, respectively, of baffles which the scroll of the invention is fitted with.

Description of preferred embodiments

With reference to FIG. 1, numeral 10 designates overall an inner rotating scroll for a centrifugal separator. A conventional outer rotating drum of substantially truncated cone shape (not shown) is fitted around the scroll, said drum being formed by the union of adjacent cylindrical and truncated cone drum portions. The scroll comprises an elongated central hub 14 of substantially tubular shape. A paste of crushed olives is pumped into the drum through an opening 11 formed at one end of tubular hub 14, for separating by centrifugation the liquid phases (oil and water) and the solid phase (olive

husk) composing said paste.

The olive paste is distributed radially by centrifugation from an inlet zone 12 located proximate to the opening 11 and closed by a radial wall 13. The remainder of tubular hub 14, to the right of radial wall 13, is empty.

Formed at the peripheral part of the scroll is a dual spiral 15a, 15b of conventional design for conveying the olive husk accumulated in this peripheral part towards an outlet 16 proximate to the tapered axial end portion of the scroll (to the right in FIG. 1). The two liquid phases, oil and water, are expelled through respective outlets (not shown) located at radially distinct levels near the left end portion of the scroll.

According to the present invention, fixed along the outer wall of tubular hub 14, preferably by welding, is a plurality of baffles or axial walls 20, oriented according to axial planes angularly equally spaced around the tubular hub 14.

Referring also to FIG. 2, the baffles 20 define a corresponding plurality of compartments 21 open in radially outer directions. More particularly, each compartment 21 is limited laterally by two consecutive baffles 20, and at the radially inner part by the cylindrical outer surface of tubular hub 14. The baffles 20 provides that the three phases being separated (oil, water, olive husk) each maintain a uniform angular speed, equal to the rotational speed of the scroll. Owing to such an arrangement, the different layers are not allowed to gain relative rotational speed with respect to each other. As a result, a clear separation is obtained between the various phases, as schematically depicted by circles A and B shown in phantom line in FIG. 2. An improved and clearer distinction of the phases allows for an increased rate of oil being expelled, this implying an advantage from the production and economic point of view.

During rotation of the scroll, in each compartment there can be clearly distinguished a radially inner oil zone 21a, an intermediate water zone 21b, and a radially outer zone 21c containing the solid phase.

The baffles 20 have a radial extension sufficient to form a barrier comprising at least the boundary zone A between the radially inner oil layer and the intermediate water layer adjacent to the oil layer. Preferably, the baffles 20 have a radial extension such as to form a barrier encompassing both the boundary zones A and B between the different liquid and solid phases separated by centrifugation.

Accordingly, there is overcome the inconvenience discussed in the introductory part of the present description, where prior art devices formed rather thick boundary zones comprising a mixture of two radially adjacent phases due to friction in the contact of layers rotating at different angular speeds.

The number of baffles 20 may vary according to requirements. Obviously, better results are attained if more than one axial baffle is provided, as shown in the illustrated examples.

The clear separation of the phases allows the liquid phases also to be extracted with greater accuracy at different levels in the centrifugal separator.

In the preferred embodiments shown in the drawings, the radial length of the baffles 20 varies following the shape of the scroll and the surrounding drum. Preferably, the radially outer edges 22 of the baffles 20 are at a substantially constant distance from the inner surface of the drum. This determines a dual helical channel 17 of constant cross section between the scroll and the drum, where the olive husk is driven in helical manner by the dual spiral 15a, 15b towards outlet 16. A constant cross section of the dual peripheral channel 17 is beneficial in that it is helpful in rendering the speed of the olive husk uniform and prevents the formation of constipated or empty zones which could adversely affect the separator efficiency.

In a preferred embodiment, the dual spiral 15a, 15b is welded to the outer edges 22 of baffles 20.

Still with reference to FIG. 1, the axial length of the baffles 20 is preferably limited to the zone of the scroll where the liquid phases are present, i.e. the inlet portion (to the left) and the median portion. Where the scroll narrows, to the right end, only the solid phase is present and the baffles are no longer indispensable to achieve the desired scope.

In FIGS. 3, 4 and 5 there are illustrated three further variants, respectively, of a scroll according to the invention. In these embodiments, in order to render the level of the liquid phase, particularly the oil, uniform in all the compartments 21, the baffles 20 have one or more passages at their radially inner parts, near the attachment to the tubular hub 14. In FIG. 3, the radially inner edges 24 of the baffles 20 are so shaped as to define with the tubular hub 14 one or more slits 23a setting adjacent compartments in direct fluid communication. In FIG. 4, the passages are formed by a plurality of recesses 23b formed in the radially inner edges 24 of the baffles. In FIG. 5, said passages are provided by bores 23c obtained adjacent to the hub 14. Moreover, in the embodiment of FIG. 5, the baffles have a reduced axial dimension and terminate at the right side forming an acute extension 25 determining a further passage zone 26 with the hub that helps in levelling the liquid phase uniformly.

While specific embodiments of the invention have been disclosed, it is to be understood that such disclosure has been merely for the purpose of illustration and that the centrifugal separator is not to be limited in any manner thereby. Various other modifications will be apparent to those skilled in the art in view of the foregoing examples.

Claims

1. A rotating inner scroll (10) for a centrifugal separator with a horizontal axis for separating the liquid and solid phases from a past of crushed olives, the

scroll comprising an elongated central hub (14) of substantially tubular shape and an outer drum of substantially truncated cone shape, characterised by comprising at least one baffle (20) oriented in an axial plane, said at least one baffle radially extending between the tubular hub (14) and the drum so as to form at least one barrier encompassing at least the boundary zone (A) between the oil and the water being separated by centrifugation.

5

10

2. A scroll as claimed in claim 1, characterised in that said at least one barrier encompasses both the boundary zones (A, B) between the liquid and solid phases separated by centrifugation.

15

3. A scroll as claimed in claim 1 or 2, characterised by comprising a plurality of axial baffles (20) oriented according to axial planes angularly spaced around the tubular hub (14) and forming a plurality of said barriers.

20

4. A scroll as claimed in claim 3, characterised in that the radially outer edges (22) of said baffles (20) are fixed to at least one spiral (15) disposed around the peripheral part of the scroll (10).

25

5. A scroll as claimed in claim 4, characterised in that the radially outer edges (22) of said baffles (20) are spaced apart from said drum so as to define with said spiral and said drum at least one peripheral helical channel (17) of substantially constant cross section.

30

6. A scroll as claimed in claim 1, characterised in that the axial length of said at least one baffle (20) is limited to the length of the scroll (10) where the liquid phases are present.

35

7. A scroll as claimed in claim 3, characterised in that said baffles are angularly equally spaced.

40

8. A scroll as claimed in claim 3, characterised in that said baffles (20) define a corresponding plurality of compartments (21) open in radially outer directions.

45

9. A scroll as claimed in claim 8, characterised in that each compartment (21) is limited laterally by two consecutive baffles (20), and at the radially inner side by the cylindrical outer surface of said tubular hub.

50

10. A scroll as claimed in claim 9, characterised in that said baffles (20) form one or more passages (23a, 23b, 23c, 26) in their radially inner zone, said passages setting the liquid present in adjacent compartments (21) in direct fluid communication.

55

Fig.1

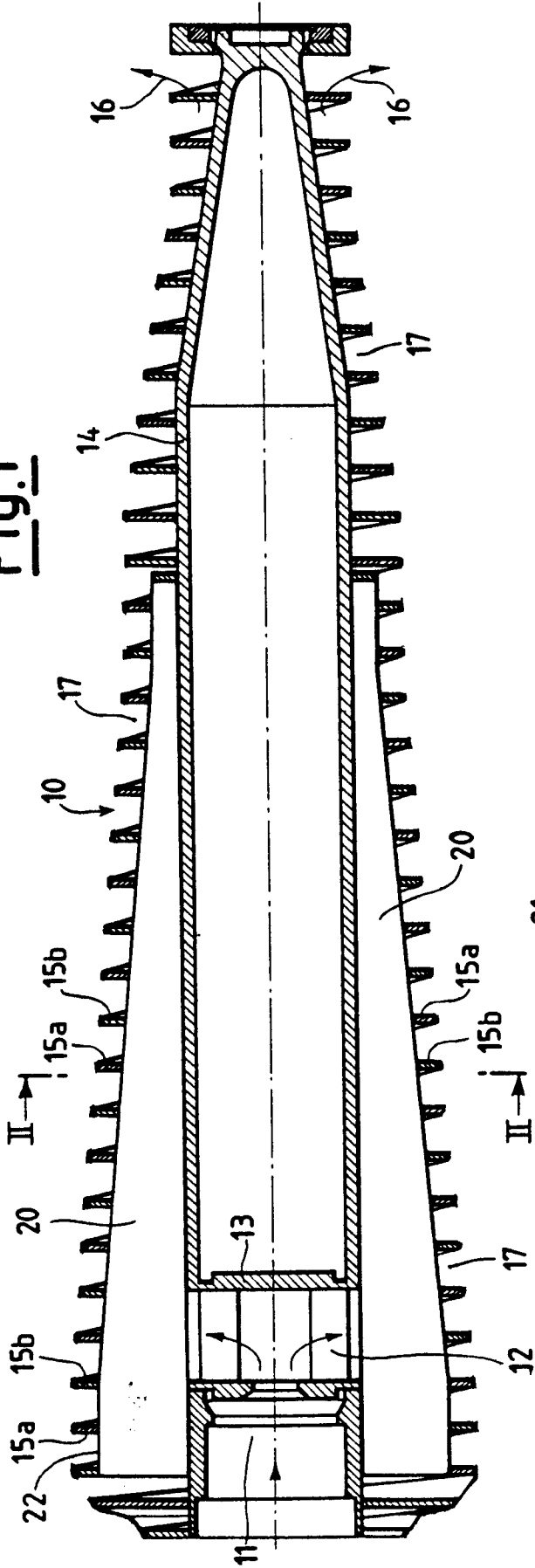

Fig.2

