

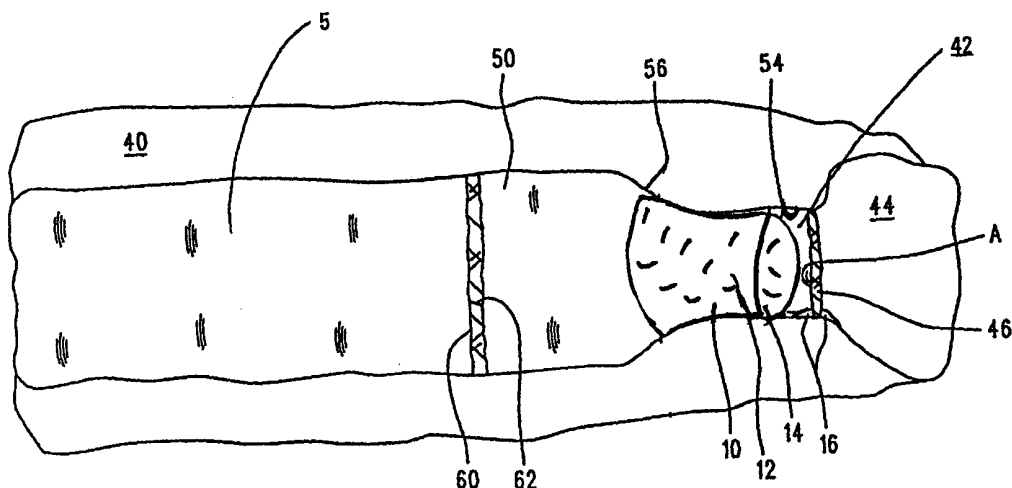

INTERNATIONAL APPLICATION PUBLISHED UNDER THE PATENT COOPERATION TREATY (PCT)

| | | |
|--|---|--|
| <p>(51) International Patent Classification ⁷ : A61F 11/00, A61K 9/00</p> | <p>A1</p> | <p>(11) International Publication Number: WO 00/33775</p> <p>(43) International Publication Date: 15 June 2000 (15.06.00)</p> |
| <p>(21) International Application Number: PCT/US99/28716</p> <p>(22) International Filing Date: 3 December 1999 (03.12.99)</p> <p>(30) Priority Data: 09/205,251 4 December 1998 (04.12.98) US</p> <p>(63) Related by Continuation (CON) or Continuation-in-Part (CIP) to Earlier Application US 09/205,251 (CIP) Filed on Not furnished</p> <p>(71) Applicant (for all designated States except US): DURECT CORPORATION [US/US]; 10240 Bubb Road, Cupertino, CA 95014 (US).</p> <p>(72) Inventors; and (75) Inventors/Applicants (for US only): ARENBERG, Irving, K. [US/US]; 5860 Goldsmith Place, Greenwood Village, CO 80111 (US). ARENBERG, Michael, H. [US/US]; 107 Birch Wood Court, Los Gatos, CA 95032 (US). LEMKE, Christine [DE/US]; 7565 E. Harvard Avenue, #307, Denver, CO 80231 (US). BERGLUND, John, A. [US/US]; 3722 Raleigh Street, Denver, CO 80212 (US). THEEUWES, Felix</p> | <p>[BE/US]; 27350 Altamont Road, Los Gatos, CA 95129 (US).</p> <p>(74) Agent: FRANCIS, Carol, L.; Bozicevic, Field & Francis LLP, 200 Middlefield Road, Suite 200, Menlo Park, CA 94025 (US).</p> <p>(81) Designated States: AE, AL, AM, AT, AU, AZ, BA, BB, BG, BR, BY, CA, CH, CN, CR, CU, CZ, DE, DK, DM, EE, ES, FI, GB, GD, GE, GH, GM, HR, HU, ID, IL, IN, IS, JP, KE, KG, KP, KR, KZ, LC, LK, LR, LS, LT, LU, LV, MA, MD, MG, MK, MN, MW, MX, NO, NZ, PL, PT, RO, RU, SD, SE, SG, SI, SK, SL, TJ, TM, TR, TT, TZ, UA, UG, US, UZ, VN, YU, ZA, ZW, ARIPO patent (GH, GM, KE, LS, MW, SD, SL, SZ, TZ, UG, ZW), Eurasian patent (AM, AZ, BY, KG, KZ, MD, RU, TJ, TM), European patent (AT, BE, CH, CY, DE, DK, ES, FI, FR, GB, GR, IE, IT, LU, MC, NL, PT, SE), OAPI patent (BF, BJ, CF, CG, CI, CM, GA, GN, GW, ML, MR, NE, SN, TD, TG).</p> <p>Published <i>With international search report. Before the expiration of the time limit for amending the claims and to be republished in the event of the receipt of amendments.</i></p> | |

(54) Title: CONTROLLED RELEASE SYSTEM FOR DELIVERING THERAPEUTIC AGENTS INTO THE INNER EAR



(57) Abstract

The present invention provides methods and devices for controlled delivery of a therapeutic agent to an internal cavity of the ear, particularly to the inner ear. In general, the invention uses a drug delivery unit for inner ear treatment which employs a portion of carrier media material containing one or more therapeutic agents therein. The carrier media material is designed to release the therapeutic agents in a controlled manner over time. The drug delivery unit is shaped and sized for placement of at least a portion thereof in the round window niche of a patient. The released therapeutic agents come in contact with the round window membrane and pass therethrough into the inner ear for treatment purposes. This system provides many benefits ranging from the ability to deliver drugs in a site specific, highly controlled manner to the transfer of such materials with minimal patient discomfort and monitoring requirements.

FOR THE PURPOSES OF INFORMATION ONLY

Codes used to identify States party to the PCT on the front pages of pamphlets publishing international applications under the PCT.

| | | | | | | | |
|----|--------------------------|----|--|----|--|----|--------------------------|
| AL | Albania | ES | Spain | LS | Lesotho | SI | Slovenia |
| AM | Armenia | FI | Finland | LT | Lithuania | SK | Slovakia |
| AT | Austria | FR | France | LU | Luxembourg | SN | Senegal |
| AU | Australia | GA | Gabon | LV | Latvia | SZ | Swaziland |
| AZ | Azerbaijan | GB | United Kingdom | MC | Monaco | TD | Chad |
| BA | Bosnia and Herzegovina | GE | Georgia | MD | Republic of Moldova | TG | Togo |
| BB | Barbados | GH | Ghana | MG | Madagascar | TJ | Tajikistan |
| BE | Belgium | GN | Guinea | MK | The former Yugoslav Republic of Macedonia | TM | Turkmenistan |
| BF | Burkina Faso | GR | Greece | | | TR | Turkey |
| BG | Bulgaria | HU | Hungary | ML | Mali | TT | Trinidad and Tobago |
| BJ | Benin | IE | Ireland | MN | Mongolia | UA | Ukraine |
| BR | Brazil | IL | Israel | MR | Mauritania | UG | Uganda |
| BY | Belarus | IS | Iceland | MW | Malawi | US | United States of America |
| CA | Canada | IT | Italy | MX | Mexico | UZ | Uzbekistan |
| CF | Central African Republic | JP | Japan | NE | Niger | VN | Viet Nam |
| CG | Congo | KE | Kenya | NL | Netherlands | YU | Yugoslavia |
| CH | Switzerland | KG | Kyrgyzstan | NO | Norway | ZW | Zimbabwe |
| CI | Côte d'Ivoire | KP | Democratic People's Republic of Korea | NZ | New Zealand | | |
| CM | Cameroon | | Republic of Korea | PL | Poland | | |
| CN | China | KR | Republic of Korea | PT | Portugal | | |
| CU | Cuba | KZ | Kazakstan | RO | Romania | | |
| CZ | Czech Republic | LC | Saint Lucia | RU | Russian Federation | | |
| DE | Germany | LI | Liechtenstein | SD | Sudan | | |
| DK | Denmark | LK | Sri Lanka | SE | Sweden | | |
| EE | Estonia | LR | Liberia | SG | Singapore | | |

window membrane, the oval window/stapes footplate, the annular ligament, and the otic capsule/temporal bone, all of which shall be considered "middle-inner ear interface tissue structures" as described in greater detail below. Furthermore, as indicated herein, the middle ear shall be defined as the physiological air-containing tissue zone behind the tympanic membrane (e.g. the ear drum) and ahead of the inner ear.

The inner ear tissues listed above are of minimal size and only readily accessible through invasive microsurgical procedures. In order to treat various diseases and conditions associated with inner ear tissues, the delivery of medicines to such structures is often of primary importance. Representative medicines which are typically used to treat inner ear tissues include but are not limited to urea, mannitol, sorbitol, glycerol, lidocaine, xylocaine, epinephrine, immunoglobulins, sodium chloride, steroids, heparin, hyaluronidase, aminoglycoside antibiotics (streptomycin/gentamycin), antioxidants, neurotrophins, nerve growth factors, various therapeutic peptides, and polysaccharides. Of particular interest in this list are compounds which are used to alter the permeability of the round window membrane within the ear using, for example, hyaluronidase and iontophoretic techniques (defined below). Likewise, the treatment of inner ear tissues and/or fluid cavities may involve altering the pressure, volume, electrical activity, and temperature characteristics thereof. Specifically, a precise balance must be maintained with respect to the pressure of various fluids within the inner ear and its associated compartments. Imbalances in the pressure and volume levels of such fluids can cause various problems, including but not limited to conditions known as endolymphatic hydrops, endolymphatic hypertension, perilymphatic hypertension, perilymphatic hydrops, perilymphatic fistula, intracochlear fistula, Meniere's disease, tinnitus, vertigo, hearing loss related to hair cell or ganglion cell damage/malfunction, and ruptures in various membrane structures within the ear.

Conventional methods for delivery of therapeutic agents to the inner ear involve filling the middle ear with a solution or other carrier of the therapeutic agent (see, e.g., Shea Otolaryngol Clin North Am. 30(6):1051-9 (1997)). Other methods use naturally-occurring materials such as gelatin (e.g., Gelfoam, see, e.g., Silverstein Ann Otol Rhinol Laryngol Suppl. 112:44-8. (1984); Lundman *et al.* Otolaryngol 112:524 (1992); Nedzelski *et al.* Am. J. Otol. 14:278-82 (1993); Silverstein *et al.* Ear Nose Throat J 75:468-88 (1996); Ramsay *et al.* Otolaryngol. 116:39 (1996); Ruan *et al.* Hear Res 114:169 (1997); Wanamaker *et al.* Am. J. Otology 19:170 (1998); Arriaga *et al.* Laryngoscope 108:1682-5 (1998); and Husmann *et al.* Hear Res 125:109 (1998)), hyaluronan or hyaluronic acid (see, e.g., WO 97/38698; Silverstein *et al.* Am J Otol. 19(2):196-201 (1998)), or fibrin glue or other fibrin-based vehicle (see, e.g., Balough *et al.* Otolaryngol. Head Neck Surg.

119:427-31 (1998); Park *et al.* Laryngoscope 107:1378-81 (1997)). Although these methods may ultimately result in delivery of drug into the inner ear (*e.g.*, by perfusion through the round window membrane), delivery of the therapeutic agent is generally not well controlled and/or use of the carrier materials may be associated with adverse side effects. For example, use of gelatin-based materials such as Gelfoam can cause fibrosis in the middle ear cavity (see, *e.g.*, Laurent *et al.* Am J. Otolaryngol 7(3):181-6 (1986); Liening *et al.* Otolaryngol. Head Neck Surg. 116:454-7 (1997)). Furthermore, naturally-occurring carrier materials generally do not retain their shape following introduction into the ear (*e.g.*, the materials are naturally viscous or become more liquid upon introduction into the ear). The changes in the shape of the carrier materials make it extremely difficult to completely retrieve the materials from the site of introduction if such should be desired (*e.g.*, to terminate therapy). Changes in the shape of the carrier material may even prevent delivery of additional therapeutic agents in subsequent treatments (see, *e.g.*, Silverstein *et al.* Am J. Otol 18:586-9 (1997), describing how gelfoam becomes paste-like and prevents future injections of this material from reaching the inner ear fluids).

Of further interest regarding the delivery of therapeutic agents to the middle ear, inner ear, and middle-inner ear interface tissue structures described in U.S. Patent Nos. 5,421,818; 5,474,529; and 5,476,446, each of which are incorporated herein by reference. U.S. Patent No. 5,421,818 describes a treatment system which comprises a reservoir portion with an internal cavity designed to retain a supply of therapeutic fluid compositions therein. The device further comprises fluid transfer means (*e.g.* pores, a semi-permeable membrane, and the like) which allows fluid materials to be delivered on-demand to, for example, the round window membrane for subsequent diffusion into the inner ear. U.S. Patent No. 5,474,529 involves a therapeutic treatment apparatus with a plurality of reservoir portions and multiple stem portions designed for implantation into, for example, the endolymphatic sac and duct using standard microsurgical techniques. Finally, U.S. Patent No. 5,476,446 discloses a therapeutic treatment apparatus comprising a reservoir portion for retaining liquid medicine materials therein, and first and second stems. The second stem can reside within the patient's external auditory canal lateral to the ear drum, with the first stem residing within, for example, an opening formed in the stapes footplate/annular ligament so that medicine materials can be delivered to the inner ear from the reservoir portion.

A different approach for transferring materials into and out of the inner ear (*e.g.*, via the round window niche/round window membrane) is disclosed in co-owned pending U.S. Patent Application No. 08/874,208 (Arenberg *et al.*) entitled "INNER EAR FLUID TRANSFER AND DIAGNOSTIC SYSTEM" and filed on June 13, 1997, which application is incorporated herein by

reference. This application describes a system in which one or more fluid transfer conduits are provided which are operatively connected to a cover member that can be placed over or at least partially within the niche to create a fluid-receiving zone. The cover member can be a plate-like structure or can comprise a compressible material. Representative compressible compositions for use with the cover member include substantially non-fluid absorbent, foam-type products such as polyethylene foam, polyether foam, polyester foam, polyvinyl chloride foam, polyurethane foam, and sponge rubber (e.g. synthetic or natural).

A still further system for transferring materials into and out of the inner ear is disclosed in co-owned pending U.S. Patent Application No. 09/121,460 (Arenberg et al.) entitled "FLUID TRANSFER AND DIAGNOSTIC SYSTEM FOR TREATING THE INNER EAR" and filed on July 23, 1998, which application is also incorporated herein by reference. This particular system employs a fluid transfer conduit comprising one or more passageways therethrough. Attached to the conduit is an inflatable bladder sized for insertion at least partially within an internal cavity of the ear (e.g., the round window niche). When inflated, the bladder engages the internal side wall of the internal cavity, thereby securing the bladder and part of the conduit within the internal cavity, thus allowing transfer of fluids to and from the internal cavity.

Notwithstanding the approaches described above which provide a number of benefits, there remains a need in the field for additional methods and devices for delivery of therapeutic agents to the inner ear. The present invention provides such methods and devices.

Summary of the Invention

The present invention provides methods and devices for controlled delivery of a therapeutic agent to an internal cavity of the ear, particularly to the inner ear. In general, the invention uses a drug delivery unit for inner ear treatment which employs a portion of carrier media material containing one or more therapeutic agents therein. The carrier media material is designed to release the therapeutic agents in a controlled manner over time. The drug delivery unit is shaped and sized for placement of at least a portion thereof in the round window niche of a patient. The released therapeutic agents come in contact with the round window membrane and pass therethrough into the inner ear for treatment purposes. This system provides many benefits ranging from the ability to deliver drugs in a site specific, controlled manner to the transfer of such materials with minimal patient discomfort and monitoring requirements.

It is an object of the present invention to provide a custom-designed system for delivering therapeutic agents to inner ear tissues and tissue regions in a highly effective manner.

It is another object of the invention to provide a system for delivering therapeutic agents to inner ear tissues and tissue regions which is accomplished with a minimal degree of surgical intervention.

5 It is another object of the invention to provide a system for delivering therapeutic agents to inner ear tissues and tissue regions which is capable of both sustained and controlled (e.g. time-release) drug transfer in an accurate and selective manner.

10 It is another object of the invention to provide a system for delivering therapeutic agents to inner ear tissues and tissue regions which is capable of being used effectively in patients of all ages and is likewise able to deliver a wide variety of therapeutic agents in differing dosages. These dosages include microdosing situations where drugs are to be supplied in nanogram or microgram quantities.

It is a still further object of the invention to provide a system for delivering therapeutic agents to inner ear tissues and tissue regions which is accomplished with a minimal degree of patient discomfort.

15 It is a still further object of the invention to provide a system for delivering therapeutic agents to inner ear tissues and tissue regions that is safe, effective, and requires little if any physician monitoring.

20 It is an even further object of the invention to provide a system for delivering therapeutic agents to inner ear tissues and tissue regions which involves a minimal level of expense and can be used to treat a wide variety of inner ear conditions.

It is an even further object of the invention to provide a system for delivering therapeutic agents to inner ear tissues and tissue regions which provides the treating physician with a considerable degree of control over the duration of drug delivery, the rate of drug transfer into the inner ear, and the types of drugs which may be administered.

25 It is an even further object of the invention to provide a system for delivering therapeutic agents to inner ear tissues and tissue regions using a controlled release carrier media material which is combined (e.g. impregnated, filled, or coated) with one or more therapeutic agents. At least a portion of the carrier media material (e.g., in the form of a discrete unit or "mass") is then inserted at least partially into, for example, the round window niche of a patient adjacent or against
30 the round window membrane. The natural physiological environment of the round window niche (including the pH, temperature level, and moisture level thereof) cooperates with the carrier media material to cause the drug materials to be released therefrom. Where the carrier media material comprises a biodegradable material, the biodegradable material portion is absorbed into adjacent

tissue regions and thereafter metabolized by the body. Where the carrier media material comprises a non-biodegradable material which, for example, does not degrade over time in the body, such type of material is generally retained within the site of implantation throughout the course of therapy and can be later removed. In one embodiment, the carrier media material retains its shape (e.g., by virtue of cross linking) so that the drug delivery unit can be physically removed from the round window niche or other implantation site after drug delivery or when it is desirable to terminate therapy.

After release into the round window niche as discussed above, therapeutic agent passes into and through the round window membrane. This step is accomplished in accordance with a variety of physical interactions between the therapeutic agent and the round window membrane including, but not necessarily limited to, the following processes: osmosis, diffusion, electrodiffusion, electroosmosis, active/passive transport, wicking by surface tension or a combination thereof. There are other important details, modifications, and embodiments associated with this unique process which will be discussed further below. As a result, the desired therapeutic agents (e.g. drug compounds) are delivered in a controlled, complete, substantially automatic, and uniform manner with a minimal degree of patient discomfort and physician interaction. In this regard, the present invention represents a substantial advance in the treatment of inner ear tissues and otologic drug delivery.

The present invention thus involves a minimally-invasive drug delivery system and method which offers many advantages including: (1) the repeatable, accurate, efficient, and sustained active/passive delivery of therapeutic agents into the inner ear through the round window membrane (or other middle-inner ear interface structures as discussed further below); (2) the delivery of a wide variety of therapeutic agents (e.g. pharmaceutical preparations) in a safe and direct manner through the use of controlled-release carrier materials; (3) the accomplishment of effective drug delivery without overly invasive surgical procedures; (4) the ability to initiate a single drug delivery step which will result in the controlled/sustained delivery of therapeutic agents into the inner ear of a patient without further medical procedures, monitoring, or patient discomfort; and (5) achievement of the benefits described above through the use of a controlled release carrier media material which is combined with one or more therapeutic agents (e.g. pharmaceutical compositions) and placed at least partially into the round window niche of a patient in the form of a mass consisting of a pellet or other structural unit. Accordingly, the present invention represents an advance in the art of inner ear treatment, diagnosis, and medicine delivery as described in detail below.

As noted above, the present invention involves a highly effective and minimally-invasive method for the controlled and site-specific transfer (e.g. "microdosing") of physician-specified therapeutic agents into the inner ear via the round window membrane (which is centrally located within the round window niche as previously discussed). While the invention shall primarily be described herein with reference to the round window membrane/round window niche, it shall also be applicable to other internal cavities within the ear which will become readily apparent from the discussion provided below. Thus, all of the information presented herein regarding the claimed materials, methods, and their relationship to the round window niche shall be incorporated by reference relative to other internal ear cavities (natural or man-made) without limitation.

The following summary of the present invention represents a general overview of the novel features mentioned above. A more detailed disclosure of the invention will be presented later in the Detailed Description of Preferred Embodiments. To accomplish the goals recited herein, a discrete drug delivery unit is first provided. The drug delivery unit (which is sized for partial or complete placement within the round window niche or other internal ear cavity as previously noted) is comprised of two main components, namely, (1) at least one controlled release carrier media material; and (2) one or more selected therapeutic agents combined (preferably, but not exclusively, in a homogeneous manner) with the carrier media material. The term "therapeutic agents" shall be construed to encompass drugs and any other materials in liquid, solid, semi-solid, crystalline, or other forms which provide therapeutic benefits in connection with inner ear tissues or the other tissues of interest. Supplemental compositions including but not limited to plasticizers, lubricants, and the like may also be employed within the drug delivery unit in selectively-variable amounts as needed and determined by preliminary pilot testing. In this regard, the present invention shall not be restricted to any particular carrier media materials, therapeutic agents, supplemental compositions, quantities of these ingredients, and other operational parameters unless otherwise specified herein. Representative materials which may be employed in connection with the ingredients used to produce the claimed drug delivery units shall be listed below in the Detailed Description of Preferred Embodiments section.

In one embodiment, the carrier media material comprises at least one material of synthetic origin. This allows for the selection and custom design of a carrier media material that has optimum delivery and/or other desired characteristics, e.g., retention of shape, avoidance or mitigation of adverse side effects (e.g., allergic reactions, irritation, induction of fibrosis, etc.), increased drug loading or optimized drug release characteristics. In this regard, the term "synthetic" as used herein shall be defined to encompass compositions of a non-animal origin as

discussed further below, with the placement of a synthetic carrier media material directly in the round window niche constituting a novel development with a high safety profile. It should also be noted that the term "animal" as used herein shall also encompass humans. Thus, the word "synthetic" shall likewise exclude products of human origin.

5 In another embodiment, the carrier media material comprises polymeric materials that are cross linked to provide a drug delivery unit that substantially retains its shape during release of the therapeutic agent(s). For example, the cross linking of the carrier media material can be such that, upon addition of water at approximately neutral pH and at about body temperature of the subject into which the material is to be implanted, the drug delivery unit swells a substantially predicable amount. In general, the carrier material can be cross linked physically or chemical to swell a
10 predictable amount typically in the range of from about 20% to about 200% of its original dimensions. Normally the cross linked carrier material will swell at least about 25% to 100%, and may swell up to 200% or more of its original dimensions. The actual degree of cross linking will vary according to the actual material(s) cross linked, shape and size of the delivery unit, and other
15 factors that will be readily apparent to the ordinarily skilled artisan. In one embodiment cross linking is accomplished using one or more synthetic cross linking agents or by physical cross linking processes, *i.e.*, by subjecting the material to be cross linked to conditions to which the material is not naturally exposed to provide a material that does not occur in nature in the course of natural processes to which the material is exposed (*e.g.*, gamma irradiation, ultraviolet irradiation,
20 thermal cross linking, pressure, and the like). Cross linking can be accomplished through covalent bonds, ionic bonds, hydrogen bonds, or crystallization domains. Suitable cross linking agents and methods are well known in the art and will vary according to the material used and other factors that will be readily apparent to the ordinarily skilled artisan upon reading the present specification.

 The selected drug delivery unit (which may be configured in many different forms without
25 limitation including pellets, disks, spheres, cubes, cylindrical units, strands, amorphous masses, gels, pastes, and the like) is then placed within the round window niche of the subject under consideration. The term "placement" or "placed" as used herein shall involve either partial or complete insertion of the drug delivery unit into the round window niche or other ear cavity of interest (*e.g.* as much as is needed in accordance with the medical procedure[s] of interest). Since
30 a preferred embodiment of the invention will involve placement of the drug delivery unit in the round window niche, the remainder of this discussion will again focus on this location with the understanding that it is equally applicable to insertion of the drug delivery unit in other ear cavities as previously noted.

As outlined in greater detail below, the round window niche includes an internal side wall therein. Immediately upon placement of the drug delivery unit within the round window niche, the drug delivery unit will come in direct physical contact with an internal side wall of the niche. Likewise, in view of the relatively small size of the niche, insertion of the drug delivery unit therein will typically cause it to be located directly adjacent or "against" the round window membrane. The term "against" as used herein indicates that the drug delivery unit is proximal to the round window membrane and is not meant to exclude the separation of the drug delivery unit and the round window membrane by a quantity of therapeutic agent (*e.g.*, a film) or other fluid material. Both "against" and "adjacent" thus can allow for at least a minimal fluid transfer space between the drug delivery unit and the round window membrane.

The claimed method is highly effective regardless of the particular orientation of the drug delivery unit relative to the round window membrane. The drug delivery unit need only be oriented relative to the membrane and positioned within or adjacent the round window niche to as to facilitate contact of a therapeutic agent of the unit with the round window membrane. For example, where the delivery unit is designed to allow flow of therapeutic agent out of the unit, delivery of the agent to the round window membrane does not necessarily require that the delivery unit per se physically contact the round window membrane, but only that therapeutic agent that originates from the delivery unit reach and contact the round window membrane so as to facilitate diffusion of the agent into and through the membrane to reach the desired site of action within the inner ear.

Once the drug delivery unit is positioned (*e.g.* placed) at least partially within the round window niche as discussed above, therapeutic agent can be released from the carrier media material as a result of, for example, diffusion of the agent from the carrier material (*e.g.*, while the carrier material substantially retains the shape at the time of implantation), solvent drag by wicking of the solvent, dissolution of the carrier material (*e.g.*, biodegradation of the carrier material), or electrodiffusion from the carrier material. As a result, the drug delivery unit allows release of the desired therapeutic agents. The therapeutic agent may diffuse directly into the round window membrane or permeate across a fluid film in contact between the delivery unit and the round window membrane. The term "allows" as used in connection with the release of therapeutic agents from the drug delivery unit shall involve leaving the drug delivery unit in the patient until therapeutic agent release occurs on a partial or complete basis. This may involve a time period ranging from minutes to hours depending on the compositions under consideration. The precise physical mechanism associated with drug release will depend on the particular carrier media

material being used as discussed below. Therapeutic agent release is accomplished over time in accordance with the unique physical environment of the round window niche including its pH, temperature, moisture characteristics, the type of carrier medial material being employed, and other comparable factors. If the carrier media material associated with the drug delivery unit is biodegradable, it will ultimately be absorbed into adjacent tissues in the body, followed by metabolic degradation thereof. Non-biodegradable materials may be removed by the treating physician after drug delivery using a number of minimally-invasive surgical techniques.

During the foregoing process, the previously-entrained therapeutic agent will be released from the drug delivery unit and will thereafter come in contact with the round window membrane. The therapeutic agent will then pass through the membrane in accordance with a variety of natural physical processes including but not limited to osmosis, diffusion, electrodiffusion, active/passive transport, or a combination thereof. The therapeutic agents can then effectively treat the inner ear tissues of concern.

The time needed to achieve complete release of the therapeutic agent from will vary in view of numerous factors including but not limited to the type of carrier media material being employed, the overall size of the drug delivery unit, the ambient environmental conditions within the round window niche, and other considerations as determined by routine preliminary investigation. Delivery times can range from a few hours to many months which may be adjusted in accordance with the factors listed above. In one embodiment, the drug delivery unit provides for delivery over a period from at least about 36 hours to several weeks or months or more. Where the drug delivery unit is operably connected to a reservoir of therapeutic agent, delivery of the agent can be maintained over an extended course of therapy, *e.g.*, from at least about 48 hours to 12 months, generally from at least about 72 hours to about 6 months or more (*e.g.*, until the reservoir is substantially emptied or, where the reservoir is replaced or refilled, for an even more extended period (*e.g.*, for the lifetime of the subject)). In this regard, the claimed invention shall not be restricted to any drug delivery times or materials associated with the drug delivery unit as previously indicated. Likewise, specific examples of these items will again be presented below in the Detailed Description of Preferred Embodiments section.

The process described herein again offers a number of important benefits. In particular, site-specific transfer of the desired therapeutic agents into the inner ear can occur in a controlled, complete, and uniform manner with minimal patient discomfort. Likewise, as previously discussed, the claimed process is characterized by a high level of versatility in connection with (1) the size of the drug delivery units being employed; (2) the particular therapeutic agents combined

with the carrier media material; (3) the specific ingredient proportions within the drug delivery units including the concentrations of therapeutic agents (which can be varied as needed); and (4) the mechanism of dispensing medication. In accordance with these benefits, the present invention represents a significant advance in inner ear therapy which enables treatment to occur in a very efficient, substantially automatic manner with minimal monitoring requirements.

As a further note, drug delivery time may be modified (e.g. increased or decreased) in connection with a given drug delivery unit through the addition of supplemental fluid materials (including but not limited to water, saline solution, additional therapeutic agent, and the like). The need for supplemental fluid addition will be determined in accordance with routine preliminary testing on the patient and drug delivery units under consideration. Furthermore, supplemental fluid transfer to the selected drug delivery unit within the round window niche (or other internal ear cavity) may be accomplished using the particular devices disclosed in co-owned U.S. Patent Nos. 5,421,818; 5,474,529, and 5,476,446 all to Arenberg et al., as well as co-owned pending U.S. Patent Application Nos. 08/874,208 (filed on 6/13/97) and 09/121,460 (filed on 7/23/98) which are also to Arenberg et al. The quantity of supplemental fluid materials to be delivered will depend on many factors as determined by initial patient testing including but not limited to the carrier media material being employed, the desired drug delivery rate, and the like.

In an alternative embodiment to be discussed in further detail below, the drug delivery units of the present invention may be adhered to or formed on the terminal end of an elongate member. The end of the elongate member having the drug delivery unit thereon is then inserted at least partially into the round window niche as discussed above. This technique substantially facilitates insertion and subsequent physical manipulation of the drug delivery unit within the round window niche (e.g., removal when therapy is to be terminated or when delivery of therapeutic agent is complete).

The elongate member may remain attached to the drug delivery unit during release of the therapeutic agent or can be configured to detach from the drug delivery unit after placement thereof in the round window niche. On-demand detachment can be accomplished by selection of the manner in which the drug delivery unit is secured to the elongate member (for example, by choosing the proper adhesive, etc.).

In one embodiment, the elongate member can serve as a conduit for delivery of therapeutic agents for filling or refilling the drug delivery unit and/or for delivery of supplemental fluids to the drug delivery unit as described above. For example, the elongate member can be a hollow member comprising a lumen which can be substantially empty, or completely or partially filled

with an absorptive material to facilitate transport of therapeutic agent from one end of the elongate member to the opposite end comprising the drug delivery unit. Alternatively, where the elongate member can be a solid member comprised of a material which allows transport of a therapeutic agent from one end of the elongate member to the opposite end which serves as the drug delivery unit (e.g., by wicking). Where the elongate member is sufficiently long (e.g., of a length sufficient to enable the clinician to manipulate the drug delivery unit within the round window niche from a location outside the ear (or from the middle/external ear as needed), therapeutic agent can be delivered through the second end positioned, for example, on the exterior of the tympanic membrane or within the middle ear. Delivery of the agent or other supplemental fluids to the delivery unit can be further facilitated by the presence of sidewall apertures adjacent or at the portion of the elongate member in contact with the carrier material.

In another embodiment, the elongate member is operatively connected to a reservoir of therapeutic agent to facilitate delivery of supplemental fluids and/or therapeutic agent to the drug delivery unit. The reservoir, which can optionally be refillable, can be a fluid-filled bladder or pouch, or can be a reservoir of a drug delivery device (e.g., a pump), where the drug delivery device facilitates movement of fluid from the reservoir by diffusive or convective mechanism. Where the elongate member is operatively connected to a reservoir, the elongate member can comprise, for example, i) a substantially fluid impermeable or semi-permeable material, ii) a fluid-absorbent material (i.e., a material that absorbs fluid to facilitate movement of fluid from, for example, a reservoir to a desired delivery site (e.g., to the drug delivery unit or direct to the round window niche)), or iii) a combination thereof.

The present invention shall not be restricted to any particular elongate members or size parameters associated with these structures which may be varied as needed. The elongate members may involve solid rod or strip-like units, hollow members of tubular configuration, string-like elements, and the like. A hollow, tubular elongate member is of considerable value in facilitating the flow of supplemental fluid materials to the drug delivery unit as noted above (if such fluid materials are to be employed). The elongate members may be produced from many different materials including but not limited to plastics (e.g. polyethylene or silicone rubber, or polycarbonate materials suitable for medical use).

In a still further embodiment, the drug delivery unit may be formed on the terminal end of an elongate member made of an electrically conductive material (e.g. metal) which is optimally configured in the form of a wire as disclosed in U.S. Patent Nos. 5,421,818; 5,474,529, and 5,476,446 all to Arenberg et al. The terminal end of this structure (with the drug delivery unit

adhered thereto or molded thereon) can then be inserted at least partially into the round window niche, with drug delivery occurring as discussed above.

The elongate member made of conductive material (also characterized herein as an "elongate conductive member") constitutes an electrical potential transmission system which is used to transmit electrical potentials into and out of the inner ear, preferably through the round window membrane. The term "potential" shall be broadly construed to encompass any type of electrical signal, current, voltage, or impulse regardless of form, magnitude, or origin. In one embodiment discussed in substantial detail below, the elongate conductive member will involve a metallic wire, strip, or other comparable structure with a ball, loop, mushroom, flat, or spoon-shaped tip on the terminal end which preferably protrudes in an outward direction from the drug delivery unit. By placing the tip in direct physical contact with the round window membrane during use of the claimed apparatus (or in contact with tissue materials adjacent thereto which shall be deemed equivalent, namely, the mucosa/bone of the round window niche and others), a number of important steps will then take place. These steps include: (1) delivery of the drug to the drug delivery unit, followed by drug transfer into and through the round window membrane; and (2) the transmission of evoked or non-evoked electrical potentials to and/or from the membrane for therapeutic analysis and other purposes using various techniques preferably encompassed within the term "electrocochleography" or "ECoG". Iontophoresis procedures may also be facilitated using the components listed above, with this term being defined to involve a process in which electrical energy is employed to transport drug through the round window membrane.

Iontophoresis can be used to facilitate transfer of the released drug materials into and through the round window membrane.

As noted above, the selection of any given procedure for placing the drug delivery unit at least partially into the round window niche (or other designated internal ear cavity) will again be determined in accordance with preliminary pilot testing involving the patient under consideration, the conditions being treated, the materials being employed in connection with the drug delivery unit and other related factors. The present invention shall therefore not be restricted to any given approach for placing the drug delivery unit at least partially into the round window niche of a patient.

The present invention represents an advance in the art of inner ear therapy and treatment. The claimed treatment system provides numerous benefits and capabilities as previously noted including but not limited to: (1) the repeatable and sustained delivery of therapeutic agents into the inner ear via the round window membrane (or other middle-inner ear interface tissue structures;

(2) the delivery of many different therapeutic agents (e.g. pharmaceutical preparations) to the inner ear in a safe and direct manner; (3) the accomplishment of effective drug delivery without overly invasive surgical procedures; and (4) the use of a single-step method to deliver therapeutic agents into the inner ear of a patient without complex medical procedures, monitoring, and patient
5 discomfort. For these reasons and the other reasons listed below, the claimed invention represents a substantial advance in the art of otological treatment and drug delivery.

These and other objects, features, and advantages of the invention will become readily apparent from the following Brief Description of the Drawings and Detailed Description of Preferred Embodiments.

10

Brief Description of the Drawings

Fig. 1 is a front perspective view in enlarged format of a representative drug delivery unit produced from the compositions discussed herein which is suitable for use in accordance with the claimed methods.

15

Fig. 2 is a cross-sectional view in enlarged format of the drug delivery unit of Fig. 1.

Fig. 3 is a schematic representation of a drug delivery unit positioned within the round window niche of a patient adjacent to the round window membrane.

Fig. 4 is a schematic representation of a drug delivery unit having at least a portion of the unit positioned within the round window niche.

20

Fig. 5 is a schematic representation of the drug delivery unit of Figs. 1 - 2 positioned on the end of a solid, rod-like elongate member.

Fig. 6A is a schematic representation of the drug delivery unit of Figs. 1 - 2 positioned on the end of a hollow (e.g. tubular) elongate member which is partially shown in cross-section.

25

Fig. 6B is a schematic representation of a drug delivery unit positioned on the end of a hollow (e.g., tubular) elongate member (shown in partial cross-sections), which elongate member comprises apertures for flow of fluid into the drug delivery unit.

Fig. 6C is a schematic representation of an elongate member comprising a drug delivery unit and operably connected to a reservoir.

30

Fig. 6D is a schematic representation of drug delivery system comprising an elongate member comprising a drug delivery unit and operably connected to a reservoir, with the drug delivery system positioned in the ear of a subject.

Fig. 7 is a schematic representation of the drug delivery unit of Figs. 1 - 2 positioned on the end of an elongate member in the form of an electrically conductive element (e.g. a wire or the like).

Fig. 8 is a schematic representation of the drug delivery unit of Figs. 1 - 2 positioned on the conductive member of Fig. 6 which is inserted in the ear of a patient.

Detailed Description of Preferred Embodiments

Before the present devices and methods of the invention are described, it is to be understood that this invention is not limited to the particular embodiments described, as such devices and methods may, of course, vary. It is also to be understood that the terminology used herein is for the purpose of describing particular embodiments only, and is not intended to limit the scope of the present invention which will be limited only by the appended claims.

It must be noted that as used herein and in the appended claims, the singular forms "a," "an," and "the" include plural referents unless the context clearly dictates otherwise. Thus, for example, reference to "a drug delivery unit" includes one or more units, reference to "a therapeutic agent" includes mixtures of different such agents, and reference to "the method of delivery" includes reference to equivalent steps and methods known to those skilled in the art, and so forth.

Unless defined otherwise, all technical and scientific terms used herein have the same meaning as commonly understood by one of ordinary skill in the art to which this invention belongs. Although any methods and materials similar or equivalent to those described herein can be used in the practice or testing of the present invention, the preferred methods and materials are now described. All publications mentioned herein are incorporated herein by reference to disclose and describe the specific methods and/or materials in connection with which the publications are cited.

The publications discussed herein are provided solely for their disclosure prior to the filing date of the present application. Nothing herein is to be construed as an admission that the present invention is not entitled to antedate such publication by virtue of prior invention. Further, the dates of publication provided may be different from the actual publication dates which may need to be independently confirmed.

As noted above, the present invention involves a unique and highly effective method for delivering therapeutic agents into the inner ear and adjacent tissue regions via the round window membrane. The "round window membrane" consists of a thin, cellular membrane structure positioned within a cavity in the middle ear known as the "round window niche". Both of these

structures are illustrated and discussed in U.S. Patent No. 5,421,818 to Arenberg et al. which is incorporated herein by reference. The round window membrane has a number of important physical features including a semi-permeable character that enables therapeutic agents (e.g. molecules) to be readily transferred across the membrane by diffusion, osmosis, iontophoresis, active/passive transport, and the like as outlined further below. The round window membrane provides a number of unique opportunities regarding the transfer of drugs into the inner ear through the membrane. For the purposes of this invention, both the round window membrane and the round window niche shall collectively be designated herein as "middle-inner ear interface tissue structures". Likewise, the middle ear shall again be defined as the physiological air-containing tissue zone behind the tympanic membrane (e.g. the ear drum) and ahead of the inner ear. The "inner ear" basically consists of those portions of the ear contained within the otic capsule and the temporal bone which is the most dense bone tissue in the entire human body. Exemplary inner ear tissue structures of primary importance include but are not limited to the cochlea, the endolymphatic sac/duct, the vestibular labyrinth, and all of the compartments/connecting tubes which include or contain any of these components.

In order to treat various diseases and conditions associated with the inner ear, the delivery of medicines thereto is of primary importance. Representative medicines (also designated herein as "therapeutic agents") which are typically used to treat inner ear tissues in solid, liquid, semi-solid, gel, crystalline, or other forms include but are not limited to urea, mannitol, sorbitol, glycerol, lidocaine, xylocaine, epinephrine, immunoglobulins, sodium chloride, steroids, heparin, hyaluronidase, aminoglycoside antibiotics (streptomycin/gentamycin), antioxidants, neurotrophins, nerve growth factors, various therapeutic peptides, and polysaccharides. Likewise, the treatment of inner ear tissues and/or fluids may involve altering the pressure, volumetric, and temperature characteristics thereof. As previously noted, a precise balance must be maintained in connection with the pressure of various fluids inside the inner ear and its associated compartments. Imbalances in inner ear fluid pressure levels can cause numerous problems, including but not limited to conditions known as endolymphatic hydrops, endolymphatic hypertension, perilymphatic hypertension, Meniere's disease, and perilymphatic hydrops.

It is a goal of this invention to provide an effective, minimally-invasive method for transferring therapeutic agents into the inner ear which is suitable for use with a wide variety of different drugs, pharmaceutical preparations, and the like as indicated below. In particular, the method described herein is site-specific relative to the round window niche and round window membrane (or other internal ear cavities as discussed below although the round window niche is of

primary concern). It employs a highly-specialized drug delivery unit produced from a controlled release carrier media material combined one or more therapeutic agents. When placed in the round window niche, the therapeutic agents are released from the carrier media material using a variety of different physical mechanisms as indicated later in this section. The released therapeutic agents will then pass through the round window membrane by diffusion, osmosis, active/passive transport, and other applicable material transfer processes. The therapeutic agents will thereafter enter the inner ear (or other desired cavity) where treatment can occur.

Placement of the drug delivery unit directly at least partially into the round window niche greatly facilitates represents a specially-targeted delivery system which avoids premature drug delivery, and which requires only a single step to accomplish substantially "automatic", timed-release drug transfer with minimal physician monitoring and patient discomfort. The invention also ensures that the therapeutic agents will be transferred directly to the round window membrane and will not be inadvertently delivered to other tissue regions outside the round window niche. In this manner, drug delivery may be accomplished in a repeatable, sustained, and controlled fashion without the use of complex surgical devices or drug delivery sub-systems. "Sustained delivery" as used herein refers to delivery of drug over a prolonged period of time (*e.g.*, several hours to several days or longer) without regard to drug delivery pattern or rate. "Controlled release" as used herein refers to drug delivery that is regulated, *e.g.*, delivered in a selected delivery pattern with predictable and selected kinetics.

For these reasons and the other reasons listed below, the claimed invention represents a substantial advance in the art of otological treatment and drug delivery.

A. Drug Delivery Units of the Present Invention

A number of different devices produced in accordance with the claimed system may be employed to achieve the goals listed above. Various embodiments of the drug delivery units (and components associated therewith) will now be discussed in detail. Thereafter, the manner in which these systems are used in a living subject will be described. It should be noted at this time that all of the dimensions, materials, components, parameters, process steps, and construction techniques listed below are provided for example purposes only, with the present invention not being limited to these items unless so limited in the appended claims. In addition, the novel techniques presented below shall not be restricted to any particular theories of operation including the manner in which the drug delivery units dissolve or otherwise release therapeutic agents. These processes involve a number of highly-complex physical interactions which, while not completely understood, shall be explained to the maximum extent possible below. Finally, the

term "living subject" as used herein shall encompass both humans and animals, with veterinary applications also being encompassed within the present invention.

I. The Basic Drug Delivery Unit

5 With reference to Figs. 1 - 2, a structure designated herein as a "drug delivery unit" is generally illustrated at reference number **10**. The drug delivery unit **10** enables controlled drug delivery into the inner ear of a human subject, *e.g.*, via the round window niche/round window membrane as previously noted. In accordance with this goal, the drug delivery unit **10** is optimally sized for partial or complete placement (*e.g.* "at least partial placement") within the round window niche. Again, while preferred embodiments of the invention shall be described herein with primary reference to placement of the drug delivery unit **10** in the round window niche, it may be inserted into a number of other internal cavities in the ear which will become readily apparent from the discussion provided herein. Thus, all of the information presented below regarding the drug delivery unit **10**, the claimed methods, and their relationship to the round window niche shall be incorporated by reference relative to other internal ear cavities (natural or man-made) without limitation or restriction.

15 With continued reference to Figs. 1 - 2, the drug delivery unit **10** optimally consists of a soft or semi-soft (*e.g.* pliable) mass **12** of a controlled release carrier media material **14**. The mass **12** of carrier media material **14** is likewise combined with one or more therapeutic agents (*e.g.* drugs/pharmaceutical compositions in solid, liquid, gel, crystalline, or other forms) as discussed in detail below. The carrier media material **14** associated with the mass **12** is again designed to chemically release or otherwise distribute the therapeutic agents combined therewith when at least a portion of drug delivery unit **10** is placed within the round window niche of a patient. Dissolution/release will occur in accordance with the unique physical environment of the round window niche (or other selected internal ear cavity) including but not limited to its pH, temperature, and moisture characteristics (as well as the chemical characteristics of the chosen carrier media material **14**). If the carrier media material **14** is produced from a biodegradable compound, it will ultimately be dissolved, absorbed, and metabolized by the body after drug delivery or removed from the middle ear through the eustachian tube. Non-biodegradable materials may be left in position within the niche or extracted using minimally-invasive surgical techniques as outlined below. In one embodiment designed to facilitate controlled drug release, the mass **12** is optimally homogeneous and preferably of a non-porous (*e.g.* non-cellular) character so that the selected therapeutic agents may be delivered in a gradual manner over controlled time periods without undesired reabsorption back into the mass **12** (which might occur in connection

with multi-cellular materials depending on their chemical nature). Likewise, biodegradable materials are preferred and novel in the present invention when used to produce the mass **12** since they are ultimately absorbed by the body. This avoids the need to retrieve any residual materials from the round window niche during the treatment process and thus contributes to the minimally-
5 invasive character of the present invention. Accordingly, the placement of a biodegradable carrier media composition combined with one or more therapeutic agents specifically within the round window niche is a unique development which offers many benefits.

To accomplish the goals listed above, the carrier media material **14** is again designed to release a desired therapeutic agent over time so that it may be transferred into and through the
10 round window membrane. The carrier media material **14** shall not be restricted to any particular chemical compositions for this purpose. The selection of any given carrier media material **14** shall be undertaken in accordance with preliminary pilot testing involving the specific inner ear conditions to be treated, the desired treatment regimen, and other related factors. Accordingly, the methods and structures claimed herein are not "carrier media-specific" with many different
15 compositions being suitable for this purpose unless otherwise noted herein.

Exemplary and non-limiting examples of the controlled release carrier media material **14** which are suitable for use in constructing the drug delivery unit **10** will now be discussed. The following description of materials will be divided into groups for the sake of clarity and convenience.

20 1. BIODEGRADABLE MATERIALS

This group of chemical compositions is preferred in the present invention and involves many different compounds which are ultimately metabolized in a safe and effective manner by the body after drug delivery is completed. From a general standpoint, the following classes of biodegradable compounds (e.g. synthetic biodegradable materials, *e.g.*, organic polymers) may be
25 employed in connection with the carrier media material **14**: hydrophobic polyanhydrides, polyorthoesters, polyphosphazenes, polyphosphoesters/phosphoesters, polylactic/glycolipid acids, cross linked gelatin, and pseudopolyamino acids. All of these materials are considered to be "biodegradable", with this term being generally defined to involve a composition which will degrade or otherwise dissolve and thereafter be physiologically absorbed when placed within the
30 human body or other living system.

The applicable degradation processes associated with these materials primarily involve surface erosion, diffusion, or hydrolysis (depending on which biodegradable material is employed) which leads to gradual and controlled drug delivery. The rate of drug release (discussed further

below) will depend on the particular compound selected for use which, in turn, relates to the specific side chains and side chain lengths employed in the selected polymers.

The rate of drug release, as well as the rate of biodegradation, can also be dependent upon the complexity of the structure, *e.g.*, the tortuous nature of the path through which a drug molecule must move to be released from the drug delivery unit. Structural complexity can depend upon weaving or knotting of the structural material, the degree of compression used to mold the material, and/or the degree of cross linking of the material. In general, and as discussed above, cross linking is meant to encompass any physical force that allows molecules to be retained in a specific arrangement (*e.g.*, a network or mesh), including intermolecular forces and crystalline forces. In one embodiment, the biodegradable material is cross linked so that the drug delivery unit substantially retains its overall shape during all or a substantial portion of a desired period of therapy, *e.g.*, the time during which release of the therapeutic agent(s) is allowed to take place or is desired. Subsequent biodegradation of the carrier material can be associated with changes in shape of the delivery unit to allow bioabsorption or dissolution of the biodegradable material. Various cross linking agents and methods for accomplishing cross linking of biodegradable materials are well known in the art. Preferably, cross linking is accomplished so that the final cross linked material for the delivery unit are substantially non-toxic (*e.g.*, by use of thermal cross linking, gamma irradiation, ultraviolet irradiation, chemical cross linking, *etc.*). In general, the degree of cross linking relates inversely to the degree of swelling or absorption of water by the shaped polymer structure. The degree of swelling or water absorption regulates the rate of drug transport by the polymer structure.

Other factors which can influence the rate of drug delivery using biodegradable systems include but are not limited to the application of magnetic fields, ultrasound waves, and electric current, as well as changes in pH, temperature, and the like. Finally, another important consideration in controlling drug release time involves the presence of acidic or basic excipients in combination with the chosen biodegradable polymers as discussed in, for example, Leong, K., et al., J. Biomed Mater Res, 19(8):941 - 955 (1985); and Finne, U., et al., J. Pharm Sci, 80(7):670 - 673 (1991).

While a number of biodegradable compositions may be employed without limitation, polyanhydride materials (which are hydrophobic in character) represent preferred materials for the purposes listed above. These compounds are generally discussed in Laurencin, C., "Biomedical Applications of Synthetic Biodegradable Polymers", CRC Press, Boca Raton, FL (USA), pp. 59 - 102 (1995) Basically, in accordance with this reference, trimellitic anhydride is mixed with

tyrosine to form N-trimellityrosinic acid. This material is then converted into mixed anhydrides by heating at reflux temperatures in the presence of acetic anhydride. To obtain longer polymers, aliphatic spacers are employed. As discussed in further detail below, one or more selected therapeutic agents are combined with the resulting polyanhydride product using various techniques. One of these techniques is known as "trituration" in which the drug of interest and the polymer are physically ground and mixed together in powder form. Also of interest are melt molding procedures in which the polymer is heated above its melting temperature, followed by addition of the selected drug to the molten polymer. These techniques are also applicable to the other biodegradable polymers discussed herein. Additional data concerning polyanhydride compounds for drug delivery purposes is presented in Tamada, J., et al., Journal of Biomaterial Sciences, Polymer Edition, 3(4):315 - 353 (1992). Likewise, hydrophobic biodegradable polyanhydride compounds that are particularly well suited for use as the carrier media material 14 in the mass 12 associated with the drug delivery unit 10 are commercially available from Guilford Pharmaceuticals, Inc. of Baltimore, MD (USA).

Another biodegradable polymer which may be used as the carrier media material 14 involves polyorthoester compounds which are generally described in Merkli, A., et al., Journal of Biomaterial Sciences, Polymer Edition, 4:505 - 516 (1993). Commercial sources for biodegradable polyorthoester polymers which can be employed in the drug delivery unit 10 as the carrier media material 14 include but are not limited to DSL BioMedica, Inc. of San Diego, CA (USA). The combination of a polyorthoester compound with a selected drug composition (e.g. gentamycin) is described in Merkli, A., et al., Journal of Biomaterial Sciences, Polymer Edition, 4:505 - 516 (1993) as cited above and U.S. Patent No. 5,461,140. To produce, for example, a mass 12 of carrier media material 14 containing a polyorthoester composition combined with gentamycin, the reactants used to fabricate the polyorthoester polymer (namely, trimethyl orthoacetate and 1,2,6,-hexanetriol) are placed in a receptacle (e.g. a round bottom flask). Under anhydrous conditions, cyclohexane is then added. The polymerization reaction is catalyzed by the addition of p-toluene sulfonic acid. This mixture is then heated under argon with vigorous stirring and, after four hours, the residual by-products (e.g. methanol) are removed. The remaining solution is then subjected to additional heating, cooling, and the addition of triethylamine to neutralize the p-toluene sulfonic acid. The liquid materials which remain at this stage are subsequently poured off, with the remaining solid polymer being dried under a vacuum. Purification of the polymer (e.g. polyorthoester) is accomplished by adding tetrahydrofuran, with the resulting mixture being precipitated using anhydrous methanol containing small amounts of

triethylamine therein. The precipitated, purified polymer product is thereafter collected by filtration and dried in a vacuum oven.

In order to add the desired therapeutic agent (e.g. gentamycin in a non-limiting representative embodiment), the polyorthoester polymer product is first dissolved in anhydrous tetrahydrofuran. Gentamycin is then combined with the dissolved polymer in a 1:10 (gentamycin : polymer) weight ratio. The residual liquid solvent fraction is thereafter removed by evaporation to yield a pliable, semi-solid (e.g. soft) mass **12** which can be used as the drug delivery unit **10** in accordance with the procedures outlined below. It should be noted that the foregoing process is provided for example purposes only and shall not limit the invention in any respect. Other biodegradable and non-biodegradable polymeric carrier media materials can be combined with one or more therapeutic agents in a manner comparable to the procedure listed above which was provided for general guidance purposes.

A still further technique for producing the mass **12** of the drug delivery unit **10** using a biodegradable polymer as the carrier media material **14** involves a process known as "compression molding" as discussed in Laurencin, C., Biomedical Applications of Synthetic Biodegradable Polymers, CRC Press, Boca Raton, FL (USA), p. 78 (1995) as cited above. Likewise, the mass **12** of biodegradable polymer may be formulated in a sufficiently pliable manner to permit the injection of this material (using conventional hypodermic systems) at least partially into the round window niche. The biodegradable polymer may also be formulated to produce materials known as "hydrophilic microspheres". These compositions can be employed in an injectable gel for direct introduction into a patient.

While a number of other materials (and classes thereof) can be employed as the carrier media material **14** in the present invention, the use of biodegradable polymers is of particular interest. These materials can be configured in many different forms, and are ultimately broken down (e.g. chemically degraded and otherwise dissolved) within the round window niche. The dissolution products are then absorbed by the body and eliminated using natural metabolic processes. The use of a biodegradable polymer as the carrier media material **14** in the drug delivery unit **10** (Fig. 1) is likewise advantageous in accordance with its ability to dissolve (in most cases) by surface erosion. Surface erosion of the drug delivery unit **10** enables more efficient, complete, and constant release of the therapeutic agent over a time period ranging from a few hours to many months. However, the exact rate of drug delivery from the mass **12** of carrier media material **14** will depend on the many factors listed above, along with the chemical composition of the biodegradable polymer, the manner in which the therapeutic agent is distributed

within the polymer, and whether any basic or acidic excipients are added to the polymer as previously noted. Furthermore, drug distribution can be controlled by various chemical modifications to the selected polymer without limitation. For example, the polymer can be designed so that it also functions as a bioadhesive material, thereby facilitating proper retention in the round window niche and site-specific delivery of the desired drug. The therapeutic agent and polymer can also be selected so that they will covalently bond to each other instead of simply being mixed. This particular process will substantially influence the rate of drug delivery. Finally, multiple biodegradable polymers with differing dissolution characteristics can be combined to produce a multi-phase, composite drug delivery unit **10** with one or more "zones" that will dissolve faster than other zones. In this manner, the rate of drug release can be controlled and otherwise manipulated.

Biodegradable polymers suitable for use herein are commercially available from many sources including those listed above. A further source of these materials is Alkermes, Inc. of Cambridge, MA (USA). Regardless of which biodegradable polymer is selected for use in this embodiment, the combination of at least one of these materials with one or more therapeutic agents (discussed in detail below) provides many benefits. These benefits again include the ability to achieve highly-controlled drug delivery with minimal monitoring requirements and patient discomfort.

2. HYDROGELS

Another class of compositions which may be used as the carrier media material **14** in the drug delivery unit **10** of Fig. 1 involves a group of materials known as "hydrogels". Hydrogels (which are primarily polymeric in character) swell in water but do not degrade. Drug release using these materials is dependent upon the amount of swelling which will vary from compound to compound, taking into consideration numerous factors including the degree of cross linking in the hydrogel polymer of interest. In one embodiment, the material is cross linked so that the drug delivery unit substantially retains its overall shape during all or a substantial portion of a desired period of therapy, *e.g.*, the time during which release of the therapeutic agent(s) is allowed to take place or is desired. In another embodiment, the solid drug particles are mixed into a polymeric carrier to form a non-erodible matrix. A matrix containing less than about 20% of drug by weight will typically allow for solution diffusion of drug through the polymer network. A matrix with more than 20% of drug by weight, typically about 30% to 80% of drug by weight, will allow drug to diffuse through the aqueous channels created in the matrix when the matrix contacts the body to absorb moisture.

Representative hydrogel compounds which may be employed to produce the drug delivery unit **10** include but are not limited to polyvinyl alcohol, polyvinyl pyrrolidone, polyethylene oxide, and polyhydroxyethyl methacrylate alone or in combination. These and other hydrogel polymers are commercially available from many sources including Polysciences, Inc. of Warrington, PA
5 (USA).

To incorporate a selected therapeutic agent into a hydrogel polymer in a representative embodiment, the pH of the hydrogel is optimally reduced by about several pH units through the addition of acid materials so that premature swelling is avoided. Next, the hydrogel is heated in combination with the therapeutic agent until it is integrated into the hydrogel.

10 Also of interest within the hydrogel class are materials known as "microsponges" which are commercially available from Advanced Polymer Systems, Inc. of Redwood City, CA (USA). These compositions are produced using free-radical suspension polymerization reactions. Microsponges are manufactured from a number of polymeric precursors including but not limited to styrenics, methacrylates, and the like. Furthermore, a number of ointment materials having a
15 hydrogel character can be employed in the drug delivery unit **10** as discussed further below.

3. NONBIODEGRADABLE COMPOUNDS

The carrier media material **14** can also be produced from compositions classified as "nonbiodegradable compounds" which are capable of effective drug delivery in accordance with the present invention. While they will not biodegrade in the round window niche (or other internal
20 ear cavity), they are able to accomplish drug delivery by diffusion or other related processes. Specifically, in a drug delivery unit **10** made from materials in this group (which are primarily polymeric in character), the therapeutic agents will diffuse outwardly from the unit **10** over time in accordance with the specialized cross linked character of the nonbiodegradable polymers. The selection of any given composition within this class (as determined by preliminary pilot testing)
25 will depend on the amount of cross linking in the compound. The degree of cross linking will again control drug delivery rates. In one embodiment, the degree of cross linking is such that the drug delivery unit substantially retains its overall shape during all or a substantial portion of a desired period of therapy, *e.g.*, the time during which release of the therapeutic agent(s) is allowed to take place or is desired.

30 While the present invention shall not be restricted to any particular nonbiodegradable, primarily diffusion-type polymers, exemplary and preferred compositions within this class shall encompass without limitation polyvinyl acetate, ethylene vinyl acetate, silicone, polyethylene, polyvinyl chloride, polyurethane, and mixtures thereof. Of particular interest is the use of silicone

materials which are commercially available from numerous sources including the Dow Corning Company of Midland, MI (USA) under the name "SILASTICS". Commercial silicone products are typically supplied as a "prepolymerized" mixture which is combined with a therapeutic agent and catalyzed to complete the production process in accordance with standard techniques

5 discussed in, for example, Golomb, G., et al., *J. Pharm. Sci.*, 76:271 - 276 (1987). However, in general, the production of a drug delivery unit **10** from one or more of the materials listed above is accomplished by levigating the drug of interest in the selected polymer. This process yields a completed drug delivery unit **10** that contains about 10 - 30% by weight therapeutic agent therein.

4. SOLUBLE COMPOUNDS

10 A still further class of materials which may be used to produce the carrier media material **14** involves a group of products known as "soluble" compounds (which are primarily polymeric in nature). Representative compositions in this class include hydroxypropylmethyl cellulose and hydroxymethyl cellulose. These materials are capable of timed-release drug delivery primarily by diffusion as the polymeric material is broken-down by enzymes within the body and dissolve.

15 While this embodiment of the invention shall not be restricted to any particular soluble polymer sources, they may be commercially obtained from, for example, Union Carbide Chemicals and Plastics Company, Inc. of Bound Brook, NJ (USA).

5. MISCELLANEOUS MATERIALS

20 Various sources of additional data exist concerning the materials listed above and other compounds that can be used as the carrier media material **14** in the mass **12** of the drug delivery unit **10**. For example, U.S. Patent Nos. 4,393,931 and 5,350,580 which are incorporated herein by reference discuss the following controlled-release compositions: polyesteramides, polyglycolic acid, polyvinyl alcohol, copolymers of polyethylene oxide/polylactic acid, and copolymers of glycolide/lactide. Likewise, controlled-release drug delivery products which employ "poly-L-lactic acid" compounds are discussed in (1) Goycoolea, M., et al., *Acta Otolaryngol. (Stockh.)*, Suppl. 493:119 - 126 (1992); and (2) Goycoolea, M., et al., *Laryngoscope*, 101:727 - 732 (July 1991) which are likewise incorporated herein by reference.

30 In addition, a number of other "miscellaneous" compounds can be employed as the carrier media material **14** in the mass **12** of the drug delivery unit **10** (Fig. 1). These materials include patch-like structures sized for insertion within the round window niche which consist of an impermeable backing membrane, a rate-limiting center membrane, and a "basement" membrane containing a bioadhesive material (e.g. polycarbophil, polyvinyl pyrrolidone, polyvinyl alcohol, hydroxyethyl cellulose, hydroxypropylmethyl cellulose, and the like). The resulting patch products

(which are substantially soluble in character) can attach to mucosa (including the interior side wall of the round window niche) for variable amounts of time up to about 1 - 2 hours in duration or more. Other patch structures of interest may be constructed from bilayer mucoadhesive polymers consisting of a "fast release" layer and a "sustained release" layer in order to achieve controlled
5 drug release over a 24-hour period or longer.

The drug delivery unit **10** may also be produced from a carrier media material **14** consisting of an "ointment"-type base sold under the name "Orabase" by the Colgate-Palmolive Company of New York, NY (USA) which is a bioadhesive product. It is produced from sodium carboxymethyl cellulose, polyethylene, pectin, and mineral oil. This product can remain within the
10 body and deliver therapeutic agents for up to about 150 minutes or more in typical applications. Other ointment materials suitable for use in producing the drug delivery unit **10** include but are not limited to copolymers of polymethylvinyl ether/maleic anhydride mixed with gelatin, polyethylene, and mineral oil. A still further formula within the ointment category consists of polymethyl methacrylate mixed with water, sodium hydroxide, glycerol, and tretinoin. Likewise, other
15 ointment formulations of interest are produced from a composition known as "Carbopol" which consists of polyacrylic acid cross linked with divinyl glycol and is commercially available from, for example, the Thornley Company of Wilmington, DE (USA). This material may be used as the carrier media material **14** alone or combined with additional ingredients including but not limited to hydroxypropyl cellulose and other polymeric compounds, plasticizers, and the like. Finally,
20 another composition within this category consists of triamcinolone acetonide which is a bioadhesive-based material designed for sustained drug delivery.

Tablet-like units which employ a bioadhesive delivery system may also be used in connection with the drug delivery unit **10**. Exemplary materials in this category are basically described in U.S. Patent No. 4,226,848. This product consists of a two-layer tablet-like structure
25 having a hydroxypropyl cellulose/"Carbopol" (see above) bioadhesive layer and a lactose-based non-adhesive backing layer. An impermeable backing membrane may also be employed within this structure for unidirectional drug delivery. Other tablet systems suitable for use in connection with the drug delivery unit **10** include those produced from chitosan/alginate derivatives.

Finally, additional compositions in the "Miscellaneous" category which may be employed
30 as the carrier media material **14** include bioadhesive gels produced from hydroxypropyl cellulose (discussed above) and carbomer compounds, as well as hyaluronic acid and derivatives thereof.

Notwithstanding the information, materials, and formulations listed above, this invention shall not be limited to any particular chemical compositions in connection with the carrier media

material **14** used in the mass **12** of the drug delivery unit **10** except as otherwise noted below. The selection of any given composition within the classes listed above will involve preliminary pilot testing taking into account many factors including the specific therapeutic agents to be used, the treatment protocol under consideration, and other factors. In one embodiment, the carrier media material **14** is of synthetic origin (without any animal-derived products combined therewith) in order to avoid allergic reactions, biological rejection, and other adverse effects which may be caused by animal-derived compounds (such as gelatin materials, collagen products, and the like). In this regard, the term "synthetic" as used herein is meant to refer to materials of a non-animal origin, and thus exclude materials such as gelatin, collagen, fibrin, and others. It should also be noted that the term "animal" as used herein shall also encompass humans; thus, "synthetic" is meant to exclude products of human origin. The placement of a carrier media material **14** comprising at least one synthetic carrier media material directly in the round window niche constitutes a novel development with a high safety profile. The synthetic material of the carrier media material can also be mixed or combined with a non-synthetic material. Representative synthetic carrier media materials **14** again include those listed above. For example, exemplary synthetic carrier media materials **14** include but are not limited to hydrophobic polyanhydrides, polyphosphazenes, polyvinyl alcohol, polyvinyl pyrrolidone, ethylene vinyl acetate, silicone, and others.

Next, with reference to the cross-sectional view of Fig. 2, the mass **12** associated with the drug delivery unit **10** includes at least one therapeutic agent **16** which is combined with the carrier media material **14** as discussed above. The terms "combined," "comprises," and "comprising" as they apply to the carrier media material **14** and the therapeutic agent **16** shall encompass many different situations. For example, these terms will involve mixtures of both materials in which the therapeutic agent **16** is dispersed randomly, uniformly, or in one or more discrete locations within the carrier media material **14**. Likewise, the therapeutic agent **16** may be positioned entirely inside the carrier media material **14** or can be dispersed on the outside of the carrier media material **14** as a coating on all or part of the surface thereof. The drug may be coated onto strands of polymer filaments which may be woven together as a multistrand cable or woven cloth-like structure. Accordingly, the present invention shall not be limited to any manner in which the therapeutic agent **16** is combined with the carrier media material **14**.

In the embodiment of Fig. 2 (which is provided for example purposes only), the therapeutic agent **16** is randomly dispersed throughout the carrier media material **14** in discrete zones as illustrated. The location of the therapeutic agent **16** within the carrier media material **14** will influence the rate of drug delivery. For example, therapeutic agents **16** that are "buried" deep

within the carrier media material **14** will normally take longer to be released compared with a drug delivery unit **10** having the therapeutic agents **16** located at the surface of the carrier media material **14**. Thus, by modifying the location of the therapeutic agent **16** within the carrier media material **14**, drug release time can be controlled as needed and desired.

5 Regarding the particular therapeutic agents **16** which can be employed in the drug delivery unit **10**, this term shall be construed to cover a wide variety of materials including drugs, pharmaceutical preparations, and the like. A single therapeutic agent **16** or multiple therapeutic agents **16** can be employed, depending on the conditions being treated. Likewise, the therapeutic agents **16** retained on or within the drug delivery unit **10** can involve liquids, solids (e.g. powders, 10 crystals, microspheres, and the like), gels, pastes, and any other forms which are necessary as determined by routine preliminary testing. In order to treat various conditions of the inner ear (and other tissue regions), a number of medicines are important. Representative materials encompassed within the phrase "therapeutic agents" that are of primary interest include but are not limited to urea, mannitol, sorbitol, glycerol, lidocaine, xylocaine, epinephrine, immunoglobulins, sodium 15 chloride, steroids, heparin, hyaluronidase, aminoglycoside antibiotics (streptomycin/gentamycin/ampicillin), antioxidants, steroids, anesthetics, neurotrophins, nerve growth factors, therapeutic peptides, polysaccharides, artificial perilymph, iron chelators, calcium antagonists, glutamate antagonists, dopamine agonists, gamma-aminobutyric acid, interleukin converting enzyme inhibitors, calpain inhibitors, C-type natriuretic peptides, cochlear blood flow 20 agents, prostaglandins, gene therapy agents, cytotoxic agents, osmotic drugs, antihistamines, cholinergic compounds, anti-viral drugs, and the like. Either a single therapeutic agent **16** or multiple therapeutic agents **16** in combination can be employed.

From a therapeutic standpoint, the treatment of inner ear tissues and/or fluids may involve altering the pressure, volumetric, and temperature characteristics thereof. A precise balance must 25 be maintained in connection with the pressure of various fluids inside the inner ear and its associated compartments. Imbalances in inner ear fluid pressure levels can cause numerous problems, including but not limited to conditions known as endolymphatic hydrops, endolymphatic hypertension, perilymphatic hypertension, Meniere's disease, and perilymphatic hydrops as previously noted. Thus, the delivery of therapeutic agents to the inner ear in accordance with the 30 site-specific method of the present invention provides many important benefits including the control of inner ear pressure levels. It should also be noted that this invention shall not be limited to any particular therapeutic agents, with the compositions listed above being provided for example purposes. Many different materials can be employed depending on numerous factors

including the specific condition being treated, the overall physical state of the patient, and other related factors. Thus, the present invention shall not be considered "therapeutic agent-specific".

As previously indicated, either a single therapeutic agent **16** or multiple therapeutic agents **16** can be employed in connection with the drug delivery unit **10** as again determined by the particular needs of the patient under consideration. Likewise, a single carrier media material **14** or multiple carrier media materials **14** can be used in combination to control drug delivery in a very precise manner. If a single carrier media material **14** is employed, the resulting drug delivery unit **10** will be characterized as a "single phase" system. A drug delivery unit **10** with multiple carrier media materials **14** therein is appropriately classified as a "multi-phase" system. Both of these systems can be used with the therapeutic agents **16** listed above (and other materials) to treat a variety of conditions including but not limited to tinnitus (inner ear origin), vertigo (inner ear origin), sensorineural hearing loss, and Meniere's disease.

As previously noted, all of the various embodiments of the drug delivery unit **10** described in this section shall not be restricted to any specific numerical parameters and formulations. However, in a representative and preferred embodiment, the mass **12** associated with the drug delivery unit **10** will contain about 60 - 90% by weight total carrier media material **14** (whether a single media material **14** or multiple media materials **14** are employed, with the above-listed range involving the total [combined] amount of carrier media materials **14**). Likewise, the mass **12** associated with the drug delivery unit **10** will optimally comprise about 10 - 40% by weight total therapeutic agent **16** (whether a single therapeutic agent **16** or multiple agents **16** are employed, with the above-listed range involving the total [combined] amount of therapeutic agents **16**). The above-listed ranges are independent of the manner in which the therapeutic agent **16** is dispersed on or within the carrier media material **14** and the type of therapeutic agent **16** under consideration.

Likewise, as needed and desired in accordance with routine preliminary investigation, a number of optional supplemental ingredients (not shown) can be employed within the mass **12** without restriction. The claimed invention shall not be restricted to any particular supplemental ingredients or mixtures thereof. Exemplary supplemental ingredients include but are not limited to plasticizers, lubricants, fillers, and the like (preferably of synthetic origin) which may be employed within the drug delivery unit **10** in selectively variable amounts. In a representative and non-limiting embodiment, the mass **12** associated with the drug delivery unit **10** will typically contain about 5 - 10% by weight total combined supplemental ingredients (if used), with the respective quantities of the carrier media material **14** and the therapeutic agent **16** being correspondingly

reduced in a proportionate amount based on the quantity of optional supplemental ingredients being employed.

The drug delivery unit **10** illustrated in Figs. 1 - 2 is configured substantially in the shape of a cylinder. However, the drug delivery unit **10** of the invention may be produced in many different forms without limitation including pellets, disks, tablets, plates, spheres, cubes, cylindrical units (Figs. 1 - 2), strands, plugs, amorphous masses, portions of gel/paste materials, and the like which are sized for placement at least partially within the round window niche (or other desired internal ear cavity). The term "placement" or "placed" as used herein shall involve either partial or complete insertion of the drug delivery unit **10** into the round window niche or other internal ear cavity of interest (e.g. as much as is needed in accordance with the medical procedures under consideration.)

Regarding the size characteristics of the mass **12**/drug delivery unit **10**, they will differ from patient to patient depending on the age of the subject, the cavity in which the drug delivery unit **10** is to be inserted, and other factors. Prior to the treatment of a particular patient, a preliminary assessment may be undertaken in order to select the optimum size characteristics of the drug delivery unit **10** in order to achieve a maximum degree of effectiveness. Taking all of these factors into consideration, it can again be stated that the mass **12** associated with the drug delivery unit **10** should be sized for placement either entirely or partially (e.g. "at least partially") within the round window niche of a living subject or other internal ear cavity in an alternative embodiment. To accomplish this goal, a number of representative dimensions will now be provided which shall be regarded as non-limiting.

With reference to Fig. 1, the mass **12** associated with the drug delivery unit **10** will be substantially cylindrical (e.g. circular in cross-section) with a representative length "L" of 0.5 - 20 mm and diameter "D" of about 0.5 - 4 mm. These dimensional ranges should encompass human subjects and animals of varying age, and will likewise be applicable to the round window niche and the other internal ear cavities of importance as outlined further below. The foregoing dimensions may be translated to all other shapes associated with the drug delivery unit **10** of the present invention, with any needed adjustments being made in accordance with the size characteristics of the patient being treated. The diameter can further be adjusted to change along its entire length and be different at different positions along its length. Again, the exact dimensions associated with the selected drug delivery unit **10** may be varied within the ranges listed above or as otherwise needed in accordance with preliminary observation and assessment of the patients under consideration.

B. Insertion of the Drug Delivery Unit 10 in Position

Many different methods, techniques, and approaches may be used for inserting the drug delivery unit 10 into a patient provided that the unit 10 ultimately resides within the desired cavity (e.g. the round window niche). The term "resides" as used herein shall involve a situation in which the drug delivery unit 10 is located entirely or partially ("at least partially") within the round window niche, either spaced apart from the round window membrane or positioned against and/or adjacent the membrane. The drug delivery unit 10 may fill the niche entirely or only partially. Furthermore, the drug delivery unit 10 may actually be larger than the niche, with only a portion of the unit 10 fitting into the niche. It shall therefore be understood that placement of the drug delivery unit 10 in the round window niche will encompass all of the variations listed above without limitation. Likewise, while the following discussion will focus on the round window niche, it shall be applicable to insertion of the drug delivery unit 10 in other internal ear cavities as further defined later in this section although it is a particularly novel development to place the drug delivery unit 10 in the round window niche as discussed herein.

Many different methods may be used to insert the mass 12 associated with the drug delivery unit 10 at least partially into the round window niche as previously noted, ranging from injection into the round window niche through the tympanic membrane if an injectable polymeric material is employed to surgical procedures of a minimally-invasive nature. These surgical procedures are of primary interest and will now be discussed. All of the methods and techniques discussed below shall be applicable to the drug delivery unit 10 regardless of its shape, form, or chemical content. Furthermore, the structures of the human ear illustrated in Figs. 3 and 7 are schematic in nature and enlarged for the sake of clarity. Furthermore, not all structures of the ear are illustrated (e.g., the bones of the middle ear) in order to simplify illustration of the various embodiments of the invention, e.g., various positioning of the drug delivery unit within the round window niche. The figures provided herein are not meant to be anatomically correct, but rather only schematic and illustrative. More detailed information concerning these structures is provided in U.S. Patent No. 5,421,818 and in Netter, F. Atlas of Human Anatomy, 2nd Ed., 1997, Novartis, East Hanover, NJ, each of which is incorporated herein by reference.

Fig. 3 is a schematic, partial cross-sectional view of the ear 40 in a human subject illustrating the drug delivery unit 10 of Figs. 1 - 2 inserted therein. Applicants note that representations of the structures and middle and inner ear, as in Figs. 3 and 7, are not intended to be anatomically correct, but instead provide a general schematic of the positioning of the drug delivery unit within the ear according to one embodiment of the invention. As shown in Fig. 3, the

drug delivery unit **10** is positioned so that it is entirely located within the round window niche, generally designated in Fig. 3 at reference number **42**. The inner ear is shown at reference number **44**, with the specific components of the inner ear **44** (including the cochlea, the labyrinth, the endolymphatic sac, and the endolymphatic duct) being omitted for the sake of clarity and
5 illustrated in U.S. Patent No. 5,421,818. The schematic includes the ear canal **5** external to the tympanic membrane **60** for orientation. The round window membrane is generally designated at reference number **46**, and constitutes an interface tissue structure between the middle ear **50** and the inner ear **44**. The round window niche **42** basically consists of an internal cavity **52** which further includes an interior side wall **54** and a main opening **56** leading into the internal cavity **52**.
10 The drug delivery unit **10** is located in Fig. 3 at a position which is spaced apart (and outwardly) from the round window membrane **46**. However, in an alternative embodiment, the drug delivery unit **10** may be placed at position "A" in Fig. 3 where it would come in direct contact with the round window membrane **46** and thereby be positioned against this structure.

Fig. 4 is a schematic showing an alternative embodiment, in which drug delivery unit **10** is
15 partially within the round window niche **42**. In this exemplary embodiment, the drug delivery unit **10** can be held within the round window niche **42** by virtue of contact between the unit **10** and an interior side wall **54** of the internal cavity **52**. This contact can result from, for example, use of a swellable material for the carrier material of unit **10**. As with the embodiment illustrated in Fig. 3, drug delivery unit **10** is located in Fig. 4 at a position which is spaced apart (and outwardly) from
20 the round window membrane **46**. Alternatively, drug delivery unit **10** may be placed at position closer to the round window membrane, where it may come into close proximity up to contact with the round window membrane **46**. Alternatively, drug delivery unit **10** may be placed at a position within the niche **42** more distant from the round window membrane **46**, particularly where unit **10** establishes a fluid receiving zone between a wall or portion of unit **10** and the round window
25 membrane **46**, *e.g.*, so as to facilitate contact of therapeutic agent with the round window membrane **46**.

Insertion of the drug delivery unit **10** in the embodiments of Figs. 3 and 4 is accomplished by passing the unit **10** (using an appropriate microsurgical instrument of conventional design) through the tympanic membrane **60**. The tympanic membrane **60** preferably has an incision **62**
30 therein that allows the drug delivery unit **10** to pass therethrough. The drug delivery unit **10** may alternatively pass beneath a tympanomeatal flap (not shown) depending on the techniques chosen by the surgeon. If an injectable carrier media material **14** is employed in connection with the drug delivery unit **10**, the needle portion of the injection system (not shown) is passed through the

incision **62** in the tympanic membrane **60** (or through the tympanomeatal flap) in the same manner discussed above in connection with the non-injectable drug delivery unit **10** of Fig. 1. It should likewise be noted that proper orientation and/or insertion of the drug delivery unit **10** within a patient may be accomplished through the use of a conventional operating microscope or otologic
5 endoscope apparatus of the type disclosed in U.S. Patent No. 5,419,312 to Arenberg et al. (incorporated herein by reference).

At this point, it shall again be emphasized that the present invention is not limited to (1) any methods for placement of the drug delivery unit **10** in position within the ear **40**; and (2) any particular orientation in connection with the drug delivery unit **10** provided that it is at least
10 partially positioned within the round window niche **42** in a preferred embodiment. Placement of the drug delivery unit **10** in the niche **42** will cause it to come in contact with at least a portion of the interior side wall **54**. As a result, drug delivery is facilitated. In addition, packing materials of the type normally used for medical applications can be employed within the ear **40** to further secure the drug delivery unit **10** in its desired location. Once the drug delivery unit **10** is in position
15 (*e.g.*, as shown in Figs. 3 and 4), it can then be used to deliver the therapeutic agent **16** of interest into the inner ear **44** via the round window membrane **46**. Specifically, the drug delivery unit **10** at this stage is "allowed" to release the therapeutic agent **16** therefrom in accordance with the mechanisms discussed herein. The term "allowed" as used in connection with the release of therapeutic agents **16** from the drug delivery unit **10** shall comprise leaving the drug delivery unit
20 **10** in the patient (*e.g.* the round window niche **42**) until therapeutic agent delivery occurs on a partial or complete basis. This may involve a time period ranging from minutes to hours, depending on the compositions under consideration.

The released therapeutic agent **16** subsequently flows by gravity, electrodiffusion, by pump, diffusion through the contact fluid between the unit **10** and the round window membrane
25 **46**, or other comparable forces/interactions toward and into the round window membrane **46**. Thereafter, the therapeutic agent **16** can travel through the round window membrane **46** and into the inner ear **44** for the treatment of tissues, fluids, fluid compartments, and tissue regions therein. Passage of the therapeutic agent **16** through the round window membrane **46** takes place in accordance with the unique permeable character of this structure as discussed in detail above and
30 in U.S. Patent No. 5,421,818. A number of physical processes can occur regarding passage of the therapeutic agent **16** through the round window membrane **46** including but not limited to osmosis, diffusion, active/passive transport, and the like.

The manner in which the therapeutic agent **16** is released from the drug delivery unit **10** will again depend on the particular carrier media composition **14** that is employed. Delivery of the therapeutic agent **16** is described above in connection with the multiple carrier media materials **14** which may be used in this invention. Specifically, release of the therapeutic agent **16** from the drug delivery unit **10** can occur via many different processes ranging from biodegradation if the carrier media material **14** is biodegradable to the swelling of hydrogel materials if these compounds are employed as the carrier media material **14**. In addition, it may also be possible or desirable as determined by routine preliminary testing to add one or more supplemental fluid materials (e.g. water, saline solutions, additional therapeutic formulation, and the like) into the round window niche **42** along with the drug delivery unit **10**. Such supplemental fluid materials can be provided to, for example, facilitate more rapid and uniform release of the therapeutic agent **16** and/or to provide for "re-filling" of the drug delivery unit. Supplemental fluid delivery may be accomplished using a conventional syringe apparatus inserted in the same manner discussed above relative to the drug delivery unit **10** (e.g. via an incision **62** in the tympanic membrane **60** or through a tympanomeatal flap [not shown]). However, the present invention shall not require supplemental fluid delivery which is an optional procedure that may be used if needed or desired, with the delivered quantity of supplemental fluid being determined by routine preliminary testing. Furthermore, delivery of the supplemental fluid can be accomplished in many other ways, including transfer using the procedures, devices, and components disclosed in co-owned U.S. Patent Nos. 5,421,818; 5,474,529, and 5,476,446 all to Arenberg et al., as well as co-owned and pending U.S. Patent Application No. 08/874,208 (filed on June 13, 1997) and No. 09/121,460 (filed on July 23, 1998) both to Arenberg et al. as cited above.

Drug delivery times and rates will vary from one carrier media composition **14** to another. Delivery times can range from minutes to many months, with the particular carrier media composition **14** of interest being selected in accordance with the desired delivery time as again determined by routine experimental testing. This testing will also take into account the effects of pH, moisture levels, and other environmental factors associated with the round window niche **42** which typically have an influence on drug release rates.

C. Additional Embodiments

Many variations of the drug delivery unit **10** and claimed drug delivery methods within the scope of the invention are possible. These variations all incorporate the novel concept described herein, namely, the placement of a controlled release, therapeutic agent-containing drug delivery unit **10** at least partially into the round window niche of a patient (or other internal ear cavity),

followed by drug release from the unit **10**. Thus, all of the information, data, techniques, materials, and procedures discussed above in connection with the previous embodiments are equally applicable to and incorporated by reference in this section of the present discussion.

An alternative drug delivery apparatus involves placement of the drug delivery unit **10** on the end of an elongate member of variable size, shape, and construction material so that the unit **10** can be appropriately placed within the round window niche **42**. This embodiment of the invention shall not be limited to any particular construction materials, sizes, or shapes in connection with the elongate member.

The elongate member may be provided in any of a variety of configurations, and may be hollow, solid, stiff, flexible, porous, elastomeric, or a combination of these characteristics. In various embodiments, the elongate member can comprise, for example, i) a substantially fluid impermeable or semi-permeable material, ii) a fluid-absorbent material (*i.e.*, a material that absorbs fluid to facilitate movement of fluid from, for example, a reservoir to a desired delivery site (*e.g.*, to the drug delivery unit or direct to the round window niche)), or iii) a combination thereof. Many different construction materials can be employed for this purpose including, but not limited to, plastic compounds (*e.g.* polyethylene, polycarbonate, polyurethane, polyvinylchloride, cellulose acetate, ethylene vinyl acetate, cross linked polyvinyl alcohol, polylactic glycolic acid, polyorthoesters, polypropylene, silicone, natural rubber, polystyrene butadiene, and other medically acceptable plastics and polymers), metallic compositions (*e.g.* stainless steel, titanium, silver alloys, and the like), metal coated polymers biocompatible polymers (*e.g.*, polyvinyl acetate, cellulose), or any other materials or mixtures of materials that are acceptable for medical use in the ear. Where a wicking material is desired, the wicking material can be any material having a fluid and fluid/drug formulation combination that exhibits a low contact angle to "wet" the surface of the polymer strands of the material. The use of surfactants in the fluid/drug formulation can enhance wicking. Typical materials that wick aqueous media are cellulose fibers such as yarn, cotton fibers, delipidized wool fibers, cross linked gelatin fibers, cross linked gelatin matrix structures, or porous matrix structures designed from the materials described above..

The overall length of the elongate member may also be varied as needed, ranging from about 0.5 mm to about 15 cm, in some embodiments from about 5-20 mm to about 10 cm, or from about 500 mm to about 5 cm according to the embodiment used and as determined by routine preliminary testing. In a preferred embodiment, the elongate member will be sufficiently long to enable the treating physician to manipulate the position of the drug delivery unit **10** within the round window niche **42** of a patient from a location outside the ear (or from the middle/external ear

as needed), *e.g.*, to anchor the elongate member in the tympanic membrane, to deliver drug from outside the ear canal, *etc.*

Figs. 5 -7 schematically illustrate various elongate members having the drug delivery unit **10** secured thereto or, in some embodiments, therein. Attachment of drug delivery unit **10** can be achieved using many different techniques including (1) molding of the drug delivery unit **10** onto the terminal end of the elongate member during production of the unit **10**; and/or (2) adhesion of the drug delivery unit **10** to the terminal end of the elongate member using one or more medically-approved adhesive compounds including a material known as "autologous fibrin glue" as described in U.S. Patent No. 4,874,368 to Miller et al. (which is incorporated herein by reference) or a cyanoacrylate compound. The amount and type of adhesive (as well as the extent to which the drug delivery unit **10** is molded onto the elongate member if this technique is chosen) will vary, depending on whether the drug delivery unit **10** is to remain on the elongate member during use or be detachable therefrom.

With continued reference to Fig. 5, a rod or shaft-like elongate member **100** is illustrated which is of solid construction and produced from one or more of the materials listed above (*e.g.* plastic). The terms "rod" or "shaft" shall encompass solid or partially solid members having a circular, square, or other cross-sectional configuration. As noted above, elongate member **100** can be flexible, and can comprise any of a variety of materials, and can provide a substantially fluid-impermeable, fluid-permeable, or fluid-absorptive material. The elongate member **100** has a proximal or first end **102** and a distal or second end **104**. The overall length " L_1 " associated with the specific elongate member **100** in one embodiment is from about 0.5 mm to about 15 cm, in some embodiments from about 5-20 mm to about 10 cm, or from about 500 mm to about 5 cm, with the thickness "T" thereof being about 0.5 - 2 mm. Both of these ranges shall be considered non-limiting and exemplary in nature. The first end **102** includes the drug delivery unit **10** attached thereto using at least one of the attachment methods listed above.

In a related embodiment, elongate member **100** comprises a fluid-absorptive material, which material can absorb fluid and facilitate transport of the absorbed fluid from elongate member second end **104** to elongate member first end **102**, where the fluid can be absorbed by drug delivery unit **10** and eventually delivered to the round window niche and the inner ear. Where the carrier material **14** comprises a fluid-absorptive material that retains its structure during delivery of therapeutic agent, the elongate member can comprise the same or similar material. In one embodiment, the elongate member is operatively connected to a reservoir so that the elongate

member absorbs fluid from the reservoir, and facilitates its delivery to the round window niche. The reservoir is optionally a refillable or replaceable reservoir.

Fig. 6A illustrates (partially in cross-section) an alternative elongate member **200** in the form of a hollow, tubular structure having a continuous side wall **202** and a lumen or passageway **204** therethrough which is surrounded by the side wall **202**. The elongate member **200** may be produced from one or more of the materials listed above, including surgical-grade plastic. In one embodiment, side wall **202** of hollow elongate member **200** comprises a substantially fluid-impermeable material. The elongate member **200** has a proximal or first end **206** and a distal or second end **210**. The overall length " L_2 " associated with the specific elongate member **200** in one embodiment is from about 0.5 mm to about 15 cm, in some embodiments from about 5-20 mm to about 10 cm, or from about 500 mm to about 5 cm, with the diameter or thickness " T_1 " thereof being about 0.5 - 2 mm. Likewise, the diameter " D_1 " associated with the passageway **204** is about 0.1 - 1 mm. Again, these ranges are provided for example purposes only and shall be considered non-limiting. The first end **206** includes the drug delivery unit **10** attached thereto using at least one of the attachment methods listed above.

The embodiment exemplified in Fig. 6A is particularly useful in accordance with its ability to transfer fluid materials and the like through the lumen or passageway **204** in the elongate member **200** if needed and desired as discussed above. For example, the hollow member can serve as a conduit for delivery of therapeutic agents for filling or refilling the drug delivery unit and/or for delivery of supplemental fluids to the drug delivery unit as described above. Where the hollow elongate member is sufficiently long (*e.g.*, of a length sufficient to enable the clinician to manipulate the drug delivery unit within the round window niche from a location outside the ear (or from the middle/external ear as needed) as described above), therapeutic agent can be delivered through the second end positioned, for example, from the exterior of the tympanic membrane or within the middle ear.

Fig. 6B provides (partially in cross-section) an example of an additional embodiment of the invention. In this embodiment, elongate member **400** is again in the form of a hollow, tubular structure comprising a continuous side wall **402** and a passageway **404** therethrough which is surrounded by the side wall **402**. The elongate member **400** comprises a proximal or first end **406** and a distal or second end **410**. The dimensions of the elongate member of this embodiment can be similar to those described above for the embodiment of Fig. 6A, again with the provided ranges being non-limiting and for example purposes only. The elongate member **400** comprises an attached drug delivery unit **10** at at least first end **406**. Delivery of therapeutic agent or other fluids

through the hollow elongate member and to the delivery unit is further facilitated by the presence of at least one side wall aperture **415** adjacent or within a portion of the elongate member in contact with the drug delivery unit **10**. Side wall apertures **415** facilitate flow of fluid from passageway **404** to the mass **12** comprising carrier material **14**. Where the hollow elongate member comprises a side wall aperture **415**, the first end **406** can be either open, or completely or partially closed. A closed first end **406** can facilitate accumulation of fluid for delivery to the drug delivery unit **10** within a portion of the second end of the passageway **404**, thus facilitating delivery of fluid into drug delivery unit **10**. As described above, second end **410** of elongate member **400** can be operably attached to a reservoir (not shown) in a manner that provides for flow, preferably controlled or regulated flow, of fluid in the reservoir, through passageway **404**, and to and into drug delivery unit **10**. The reservoir can be refillable or readily replaceable. In another embodiment one or more sidewall apertures **415** are located in the portion of the elongate member residing in the middle ear or just outside the tympanic membrane in the outer ear. In this case the fluid that is wicked to drag drug in its volume flow will evaporate from the aperture. This evaporation will cause a continuous source of concentrated drug at the site for diffusion from drug delivery unit **10**.

In all embodiments of the invention comprising a hollow elongate member, the lumen of the hollow elongate member can be substantially empty, or completely or partially filled with an absorptive material can facilitate transport of therapeutic agent from one end of the elongate member to the opposite end comprising the drug delivery unit.

In another embodiment, exemplified by the illustration of Fig. 6C, the elongate member **500** is hollow and comprises a substantially fluid-impermeable side wall **502**. The elongate member **500** comprises a proximal or first end **506** and a distal or second end **510**. The dimensions of the elongate member of this embodiment can be similar to those described above for the embodiment of Fig. 6A, again with the provided ranges being non-limiting and for example purposes only. The elongate member **500** comprises an attached drug delivery unit **10** at at least first end **506**. Delivery of therapeutic agent or other fluids through the hollow elongate member and to delivery unit **10** is facilitated by a fluid absorbent material in the form of a surface active conduit or wick **900**. Wick **900** facilitates movement of fluid from a second end **510** of the elongate member **500** to the first end **506** and to delivery unit **10**. In one embodiment wick **900** is in direct contact with delivery unit **10** to facilitate flow of fluid into unit **10**. In an alternative embodiment, wick **900** and drug delivery unit **10** are continuous (*e.g.*, drug delivery unit **10** and wick **900** are a single unit).

The first end 506 of elongate member 500 can be either open or partially closed with the proviso that first end 506 allows for passage of fluid from the drug delivery unit 10 and out first end 506. As described above, second end 510 of elongate member 500 can be operably attached to a reservoir 550 in a manner that provides for flow, preferably controlled or regulated flow, of fluid 6 from reservoir 550, through passageway 404, and to and into drug delivery unit 10. The reservoir can be refillable or readily replaceable, and can be permanently or removably attached to elongate member 500 by use of an attachment element to provide fluid tight seal. Various attachment elements suitable for use in the invention are known in the art. In general, reservoir 550 comprises a biocompatible, substantially fluid-impermeable material.

Fig. 6D illustrates the embodiment of Fig. 6C positioned for use within the ear of a subject (schematically illustrated without regard to anatomic accuracy). Reservoir 550, which can be refillable and/or readily replaceable, can be positioned at least partially within the middle ear cavity 50 (not shown), within the external ear canal 5, and/or positioned behind the ear (not shown). Where a portion of the device is outside the ear canal, the device can be partially or completely implanted beneath the skin of the subject. For example, the reservoir can be implanted subcutaneously behind the ear, and the elongate member threaded beneath the skin to a site within the ear canal.

As briefly mentioned above, the reservoir can be a reservoir of a drug delivery device. The drug delivery device can comprise a drug release device comprising a reservoir, a distal or second end, and a proximal or first end, with the first end defining a drug delivery orifice that provides a fluid flow pathway from the reservoir and out the first end. A fluid flow pathway from the reservoir and through the orifice to the treatment site (e.g., the round window niche), can be provided by attachment of an elongate member described above, or by attachment of a catheter which in turn is attached to the elongate member. Any of a wide variety of drug release devices can be used including, but not limited to, diffusion-based delivery system (e.g., erosion-based delivery systems (e.g., polymer-impregnated with drug placed within a drug-impermeable reservoir in communication with the drug delivery conduit of the catheter of the invention), electrodiffusion systems, and the like) and convective drug delivery systems (e.g., systems based upon piezoelectric pumps, osmotic pumps, etc.). Drug release devices based upon a mechanical or electromechanical infusion pump, may also be suitable for use with the present invention. Examples of such devices include those described in, for example, U.S. Pat. Nos. 4,692,147; 4,360,019; 4,487,603; 4,360,019; 4,725,852, and the like. In general, the present invention can be used in conjunction with refillable, non-exchangeable pump systems

that are normally used to deliver a substance through a relatively impermeable catheter. In one embodiment, the drug release device is an osmotically-driven device. Exemplary osmotically-driven devices suitable for use in the invention include, but are not necessarily limited to, those described in U.S. Pat. Nos. 3,760,984; 3,845,770; 3,916,899; 3,923,426; 3,987,790; 3,995,631; 3,916,899; 4,016,880; 4,036,228; 4,111,202; 4,111,203; 4,203,440; 4,203,442; 4,210,139; 4,327,725; 4,627,850; 4,865,845; 5,057,318; 5,059,423; 5,112,614; 5,137,727; 5,234,692; 5,234,693; 5,728,396; and the like. In one embodiment, the drug release device is an osmotic pump, more particularly an osmotic pump similar to that described in U.S. Pat. No. 5,728,396, e.g., a DUROS™ osmotic pump.

10 Finally, Fig. 7 involves a further alternative system which employs an elongate conductive member **300** that functions as an electrical potential transmission system **302**. The system **302** is designed to receive evoked or non-evoked electrical potentials from middle/inner ear tissues and transmit them out of the ear for detection and analysis. Likewise, the electrical potential transmission system **302** may be employed to deliver electrical potentials to the middle/inner ear for treatment purposes regarding a number of conditions including but not limited to tinnitus.

15 In one embodiment, the electrical potential transmission system **302** will again comprise the elongate conductive member **300** which may involve a variety of different structures. For example, it is preferred that the elongate conductive member **300** consist of a thin wire **304** (e.g. #27 gauge) manufactured from titanium, silver, platinum, mixtures thereof, or other highly 20 conductive materials. The wire **304** is preferably coated with an optional layer **306** of insulation material thereon. Representative insulation materials suitable for this purpose include but are not limited to heat shrinkable Teflon® (polytetrafluoroethylene) tubing of a type that is well known in the art. The wire **304** further includes a proximal or first end **310** and a distal or second end **312** as illustrated (Fig. 7). It should also be noted that the elongate conductive member **300** may involve 25 other structures equivalent to the wire **304**. For example, a substantially flat, flexible metallic strip (not shown) may be used in place of the wire **304**, although the wire **304** is preferred. Regarding the wire **304** and structures equivalent thereto, it is again preferred that these components be coated with an insulating material as previously noted (e.g. see layer **306**), although the use of an insulating composition is not required in all cases.

30 As shown in Fig. 7, the first end **310** of the elongate conductive member **300**/wire **304** has the drug delivery unit **10** attached thereto (e.g. positioned on the layer **306** of insulation material in the embodiment of Fig. 7) using one of the methods listed above. The first end **310** of the wire **304** may further include an optional conductive spherical member **314** secured thereto (e.g.

integrally formed thereon). The spherical member **314** is preferably positioned ahead of and outwardly from the drug delivery unit **10**. The spherical member **314** is optimally manufactured from the same material used to construct the wire **304** as outlined above. Use of the spherical member **314** facilitates direct contact between the wire **304** and the ear tissues of concern (e.g. the round window membrane or other desired structures). In an alternative embodiment (not shown), the first end **310** of the wire **304** may include a rounded club or hook-like portion thereon as shown in U.S. Patent No. 5,421,818 or a loop, spoon, flat, or mushroom-shaped structure instead of the spherical member **314**. Thus, the spherical member **314** may be substituted with a number of comparable structures in a non-limiting manner. While the elongate conductive member **300** (e.g. wire **304**) is primarily discussed herein as a means to receive electrical potentials, it may again be possible to use the member **300** to apply electrical potentials to ear tissues of interest in order to (1) measure responsive stimuli therefrom; (2) treat the tissues using therapeutic electrical pulses; and/or (3) implement iontophoresis procedures. Thus, the elongate conductive member **300**/wire **304** of the claimed invention shall not be exclusively limited to the receipt of electrical potentials. In addition, the term "electrical potential" as used herein shall be broadly construed to encompass any type of electrical signal, current, voltage, or impulse regardless of form, magnitude, or origin.

The second end **312** of the wire **304** associated with the elongate conductive member **300** preferably extends outwardly from the ear of the patient. The second end **312** (if desired) is readily connected to an external monitoring apparatus **320** (Fig. 8) of conventional design which collects and characterizes resting or evoked electrical potentials received from the inner ear. Further information concerning the monitoring apparatus **320** is presented below.

As previously stated, the elongate conductive member **300** is particularly designed to receive electrical potentials which originate within selected inner ear tissues. This capability is especially useful in connection with a process known as "ECoG" which is an abbreviation for "electrocochleography". Electrocochleography is a known technique for measuring electrical potentials from the inner ear which basically involves measurement of the whole nerve-cochlear action potential (hereinafter "AP"). Alternatively, ECoG can be employed to indirectly measure hair cell electrical activity. ECoG can also be used to measure the summing potential (hereinafter "SP") within the inner ear in response to externally generated clicks, tone bursts, and/or pips. The SP is basically a D.C. distortion potential which can indicate the amount of distortion in the cochlear duct associated with endolymphatic hydrops or other changes in the inner ear. The relative amount of distortion may be expressed either as an SP/AP ratio (in response to externally-generated clicks, etc.), or as an absolute measurement in response to specific,

externally-generated tone bursts and the like. Cochlear microphonics can also be measured as well as otoacoustic emissions (hereinafter "OAE") in order to assess hair cell function or dysfunction. Finally, endocochlear potentials can be measured using the components described herein if selected portions of the elongate conductive member 300/wire 304 are operatively positioned within the cochlea rather than outside of the cochlea. Further information on ECoG is presented in Portmann, M., "Electrophysiological correlates of endolymphatic hypertension and endolymphatic hydrops: an overview of electrocochleography (ECoG)", Proceedings of the Third International Symposium and Workshops on the Surgery of the Inner Ear, Snowmass, CO (USA) July 29 - August 4, 1990 as reported in Inner Ear Surgery, edited by I. Kaufman Arenberg, Kugler Publications, Amsterdam/New York, pp. 241 - 247 (1991) and in U.S. Patent No. 5,421,818 which are both incorporated herein by reference. The elongate conductive member 300/wire 304 may also be employed in connection with iontophoresis techniques which, as previously noted, involve a modification of the permeability characteristics of the round window membrane 46 using electrical signals.

Thus, as stated above, the elongate conductive member 300 is especially useful in the implementation of conventional ECoG procedures. Resting or evoked electrical potentials received by the wire 304 through direct contact of the first end 310 (e.g. the spherical member 314) with selected ear tissues (particularly the round window membrane 46) are routed through the wire 304 to the second end 312. The second end 312 of the wire 304 is operatively connected (using conventional electrical connecting clips and the like) to the monitoring apparatus 320 as indicated above and shown schematically in Fig. 8. An exemplary monitoring apparatus 320 suitable for use herein consists of commercially available ECoG detection systems sold under the names "Viking II™" and "Spirit™" by Nicolet, Inc. of Madison, WI (USA). However, a variety of different commercial systems may be employed to receive and quantify electrical potentials delivered by the wire 304, including but not limited to computer-monitored voltage amplifier/analog-to-digital converter units known in the art. In a preferred embodiment designed for use with ECoG systems, the wire 304 is sufficiently long to enable the second end 312 to terminate at a position outside of the patient's ear 40. In this manner, attachment of the second end 312 of the wire 304 to the monitoring apparatus 320 is greatly facilitated. Dimensional information regarding the wire 304 associated with the elongate conductive member 300 will be provided below.

Use of the wire 304 as shown in Fig. 7 provides a number of important benefits including those related to ECoG and iontophoresis techniques as previously discussed. Likewise, the

operation of this particular system in cooperation with the drug delivery unit **10** will enable electrophysiological measurements to be correlated with the effects of drug materials delivered by the unit **10**. While the elongate conductive member **300** is an optional element in the present invention, it may nonetheless be used (if desired in accordance with preliminary pilot studies) on
5 any or all of the various embodiments outlined herein.

Regarding the overall length " L_3 " associated with the elongate conductive member **300**/wire **304** illustrated in Fig. 7, an optimum and non-limiting range will be from about 0.5 mm to about 15 cm, in some embodiments from about 5-20 mm to about 10 cm, or from about 500 mm to about 5 cm, or other length sufficient to accomplish the goals listed above. It should also be
10 noted that all of the elongate members which may be used in connection with the drug delivery unit **10** (including elongate members **100**, **200**, **300**) may remain attached to the drug delivery unit **10** during release of the therapeutic agent **16** as previously discussed or can be removed by appropriate physical manipulation of the elongate member so that the drug delivery unit **10** detaches therefrom. Again, the detachability of the drug delivery unit **10** will depend upon the
15 manner in which it is secured to the elongate member as previously discussed. Regarding insertion into the ear **40** of the elongate members **100**, **200**, **300** (and any structures equivalent thereto which may be used in connection with the drug delivery unit **10**), a number of different methods can be employed without limitation. While Fig. 8 specifically illustrates the elongate conductive member **300** having the drug delivery unit **10** attached thereto, it shall be understood
20 that the information provided below regarding insertion methods is equally applicable to the other elongate members associated with this invention including elongate members **100**, **200**. With continued reference to Fig. 8, the first end **310** of the wire **304** associated with the elongate conductive member **300** is optimally passed through the incision **62** in the tympanic membrane **60** (or beneath a surgically formed tympanomeatal flap [not shown]). The first end **310** of the wire
25 **304** again includes the drug delivery unit **10** operatively attached thereto. The second end **312** of the wire **304** will preferably be positioned outside the patient's ear **40** where it is attached to the equipment mentioned above (including the monitoring apparatus **320**). The first end **310** of the wire **304** and attached drug delivery unit **10** will ultimately reside within the round window niche **42**, with the spherical member **314** being in direct physical contact with the round window
30 membrane **46** for ECoG monitoring and the other purposes mentioned above. In addition, the first end **310** of the wire **304** (e.g. the spherical member **314**) can instead be placed in contact with tissue structures adjacent the round window membrane **46** which shall be deemed equivalent thereto including but not limited to the mucosa/bone of the round window niche **42** and others.

The drug delivery unit **10** may be positioned on the first end **310** of the wire **304** (e.g. on the layer **306** of insulation material in the embodiment of Figs. 7 and 8) at a location which allows the wire **304** and attached spherical member **314** to extend outwardly from the unit **10** as illustrated (Fig. 8).. Alternatively, the first end **310** of the wire **304** and spherical member **314** may be entirely
5 embedded within the drug delivery unit **10**, with the exposure thereof taking place during drug delivery when the drug delivery unit **10** erodes or otherwise dissolves (assuming that a biodegradable or dissolvable carrier media material **14** is employed). In this regard, placement of the wire **304** (including the spherical member **314**) against the round window membrane **46** may take place before, after, or during drug delivery, with all of these alternatives being considered
10 equivalent. Removal of the elongate conductive member **300** (or the other elongate members **100**, **200** discussed herein) may be achieved by reversing the process described above. Furthermore, for reference purposes, it should be noted that the combined drug delivery unit **10** and elongate member **100**, **200**, or **300** shall be characterized herein as a "drug delivery apparatus."

In a still further embodiment, the drug delivery unit **10** may be placed on or otherwise used
15 in connection with the medicine delivery devices disclosed in co-owned U.S. Patent Nos. 5,421,818; 5,474,529, and 5,476,446 all to Arenberg et al., as well as co-owned and pending U.S. Patent Application Nos. 08/874,208 (filed on June 13, 1997) and 09/121,460 (filed on July 23, 1998) also to Arenberg et al. as cited above.

The claimed drug delivery systems and methods provide numerous benefits and
20 capabilities including: (1) the repeatable and sustained delivery of therapeutic agents into the inner ear through the round window membrane [or other middle-inner ear interface structures]; (2) the delivery of many different therapeutic agents (e.g. pharmaceutical preparations) to the inner ear in a safe and direct manner; (3) the accomplishment of effective drug delivery without overly invasive surgical procedures; and (4) the use of a simplified method to deliver therapeutic agents
25 into the inner ear of a patient without complex medical procedures, monitoring, and patient discomfort. For these reasons and the other factors listed above, the present invention represents a substantial advance in the art of otological treatment and diagnosis.

As a final point of information, a preferred embodiment of the invention involves insertion of the drug delivery unit **10** (and all variants thereof) inside the round window niche of a living
30 subject (which is a novel development of primary interest). However, the drug delivery unit **10** can likewise be placed at least partially within any cavity or opening (natural or man-made) in the external auditory canal, middle ear, and/or inner ear (with all of these cavities/openings collectively being designated herein as "internal cavities"). Representative internal cavities, structures, or

regions within the ear which may receive the devices listed above include but are not limited to the oval window, operculum, endolymphatic duct, the hypotympanum, and/or any bony crevice, overhang, or other region which will assist in anchoring the present invention in position. The term "internal cavity" shall also be defined to encompass any zones or regions between adjacent tissue structures (e.g. muscles, tendons, ligaments, and the like.) All of the embodiments described herein may be used with these and other internal cavities in the same manner previously discussed in connection with the round window niche (although the round window niche is of primary interest and again constitutes a particularly novel development which offers many benefits). Accordingly, the information provided herein regarding insertion of the drug delivery unit **10** within the round window niche shall be incorporated by reference relative to other internal ear cavities without limitation. Nonetheless, it is of primary interest to specifically insert the controlled-release drug delivery unit **10** within the round window niche (compared with other ear regions). This novelty resides in the unique ability of the released drug materials to come into contact with the round window membrane which permits the rapid diffusion thereof into the inner ear. The round window niche and its special proximity to the round window membrane therefore offers a number of opportunities and efficiencies which cannot be obtained by insertion of the drug delivery unit **10** into other ear regions. Thus, by inserting the drug delivery unit **10** specifically into the round window niche, site-specific transfer of the therapeutic agents to the round window membrane is ensured. This process, in combination with the controlled release capabilities of the drug delivery unit **10**, provides a system which produces highly-effective results and avoids inadvertent drug delivery to other non-inner ear regions.

Having herein described preferred embodiments of the invention, it is anticipated that suitable modifications may be made thereto by individuals skilled in the art which nonetheless remain within the scope of the invention. For example, the invention shall not be limited with respect to the construction materials being employed, the compositions used to produce the drug delivery unit **10**, and the physiological environment in which the invention is used unless otherwise indicated. In systems involving the use of an elongate member, more than one elongate member can be employed with any given drug delivery unit. Also, more than one drug delivery unit can be used in all of the systems and embodiments disclosed herein (including those which involve one or more elongate members). In this regard, the invention shall only be construed in accordance with the following claims:

THE INVENTION THAT IS CLAIMED IS:

1. A method for delivering therapeutic agents into the inner ear of a living subject, the method comprising:

5 placing at least a portion of a drug delivery unit into a round window niche of a subject, the drug delivery unit comprising at least one synthetic carrier media material and at least one therapeutic agent combined therewith, the carrier media material releasing the therapeutic agent from the drug delivery unit over time when the drug delivery unit is placed in the round window niche;

10 wherein said placing allows release of therapeutic agent from the drug delivery unit so that the therapeutic agent contacts the round window membrane, passes through the round window membrane, and enters the inner ear of the subject.

2. A method for delivering therapeutic agents into the inner ear of a living subject, the method comprising:

15 placing at least a portion of a drug delivery unit in a round window niche of a subject, the drug delivery unit comprising at least one cross linked carrier media material and at least one therapeutic agent combined therewith, the carrier media material releasing the therapeutic agent from the drug delivery unit over time when the drug delivery unit is placed in the round window niche;

20 wherein said placing allows release of therapeutic agent from the drug delivery unit so that the therapeutic agent contacts the round window membrane, passes through the round window membrane, and enters the inner ear of the subject.

25 3. A method for delivering therapeutic agents into the inner ear of a living subject, the method comprising:

placing at least a portion of a drug delivery unit in a round window niche of a subject, the drug delivery unit comprising at least one controlled release carrier media material and at least one therapeutic agent combined therewith, the carrier media material releasing the therapeutic agent from the drug delivery unit over time when the drug delivery unit is placed in the round window niche;

30

wherein said placing allows release of therapeutic agent from the drug delivery unit so that the therapeutic agent contacts the round window membrane, passes through the round window membrane, and enters the inner ear of the subject.

5 4. A method for delivering therapeutic agents into an inner ear of a living subject, the method comprising:

 placing at least a portion of a drug delivery apparatus into a round window niche of an ear of a subject, wherein the drug delivery apparatus comprises:

 an elongate member comprising a first end and a second end; and
10 a drug delivery unit positioned at the first end of the elongate member, the drug delivery unit comprising at least one carrier media material and at least one therapeutic agent combined therewith, the carrier media material releasing the therapeutic agent from the drug delivery unit over time when the drug delivery unit is placed in the round window niche;

15 wherein said placing allows release of therapeutic agent from the drug delivery unit so that the therapeutic agent contacts the round window membrane, passes through the round window membrane, and enters the inner ear of the subject.

 5. The method of claim 4, wherein the carrier media material comprises at least one
20 synthetic material.

 6. The method of claim 4, wherein the carrier media material comprises at least cross-linked material.

25 7. The method of claim 4, wherein the carrier media material comprises at least one controlled release material.

 8. A method for delivering therapeutic agents into the inner ear of a living subject, the method comprising:
30 placing at least a portion of a drug delivery unit in a round window niche of a subject, the drug delivery unit comprising at least one cross linked carrier media material and at least one therapeutic agent combined therewith, the carrier media material releasing the therapeutic agent

from the drug delivery unit over time when the drug delivery unit is placed in the round window niche;

wherein said placing allows release of therapeutic agent from the drug delivery unit so that the therapeutic agent contacts the round window membrane, passes through the round window membrane, and enters the inner ear of the subject.

9. The method of claim 8, wherein the elongate member comprises a wick.

10. The method of claim 8, wherein the elongate member defines at least one passageway therethrough from the first end to the second end.

11. The method of claim 10, wherein the elongate member further comprises a wick disposed within the passageway, wherein the wick extends from the elongate member second end to elongate member first end, and wherein the wick is in fluid communication with the drug delivery unit.

12. The method of claim 8, wherein the elongate member second end is in fluid communication with a fluid reservoir.

13. The method of claim 8, wherein the elongate member comprises an electrically conductive material, wherein the method further contacting an internal wall of the round window niche or the round window membrane with the electrically conductive material.

14. A drug delivery apparatus for delivering therapeutic agents into an internal cavity of an inner ear of a living subject comprising:

a drug delivery unit comprising at least one carrier media material and at least one therapeutic agent combined therewith, wherein the drug delivery unit is shaped and sized for at least partial insertion into a round window niche of a subject, and wherein the carrier media material releases the therapeutic agent from the drug delivery unit over time when the drug delivery unit is placed in a round window niche of a subject.

15. The apparatus of claim 14, wherein the carrier media material comprises at least one synthetic material.

16. The apparatus of claim 14, wherein the carrier media material comprises at least one cross linked material.
17. The apparatus of claim 14, wherein the carrier media material comprises at least one controlled release material.
18. The apparatus of claim 14, wherein the apparatus further comprises an elongate member comprising a first end and a second end, wherein the drug delivery unit is positioned at the first end of the elongate member.
19. The apparatus of claim 18, wherein the elongate member is in communication with a reservoir.
20. The apparatus of claim 18, wherein the elongate member is flexible.
21. The apparatus of claim 18, wherein the elongate member defines at least one passageway therethrough from the first end to the second end.
22. The apparatus of claim 21, wherein the elongate member further comprises a wick disposed within the passageway, wherein the wick extends from the elongate member second end to elongate member first end, and wherein the wick is in fluid communication with the drug delivery unit.
23. The apparatus of claim 18, wherein the elongate member comprises an electrically conductive material.

1/7

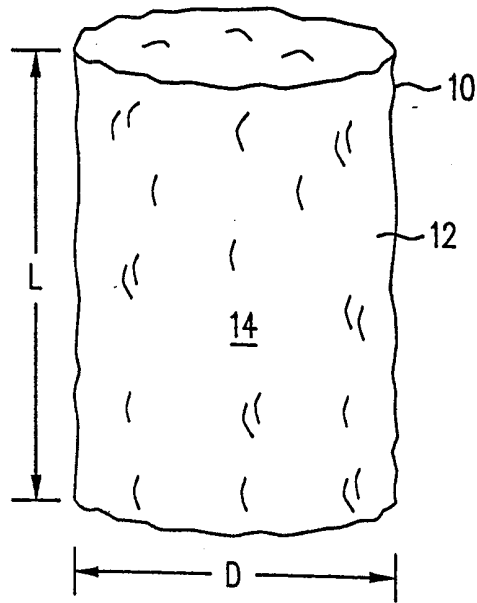

FIG. 1

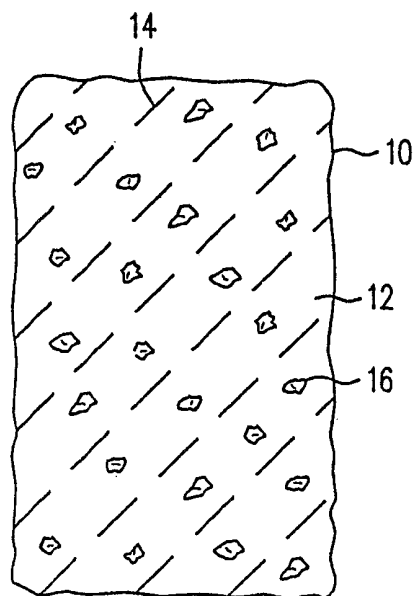

FIG. 2

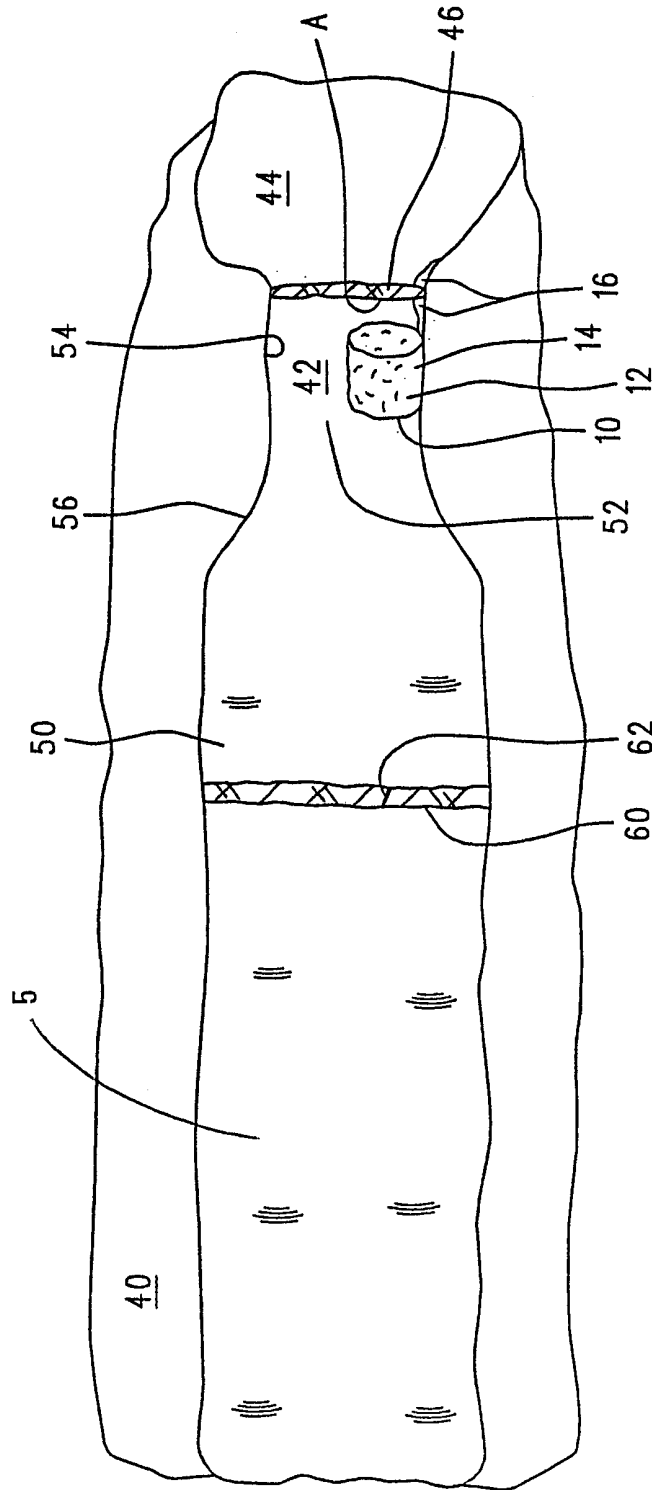

FIG. 3

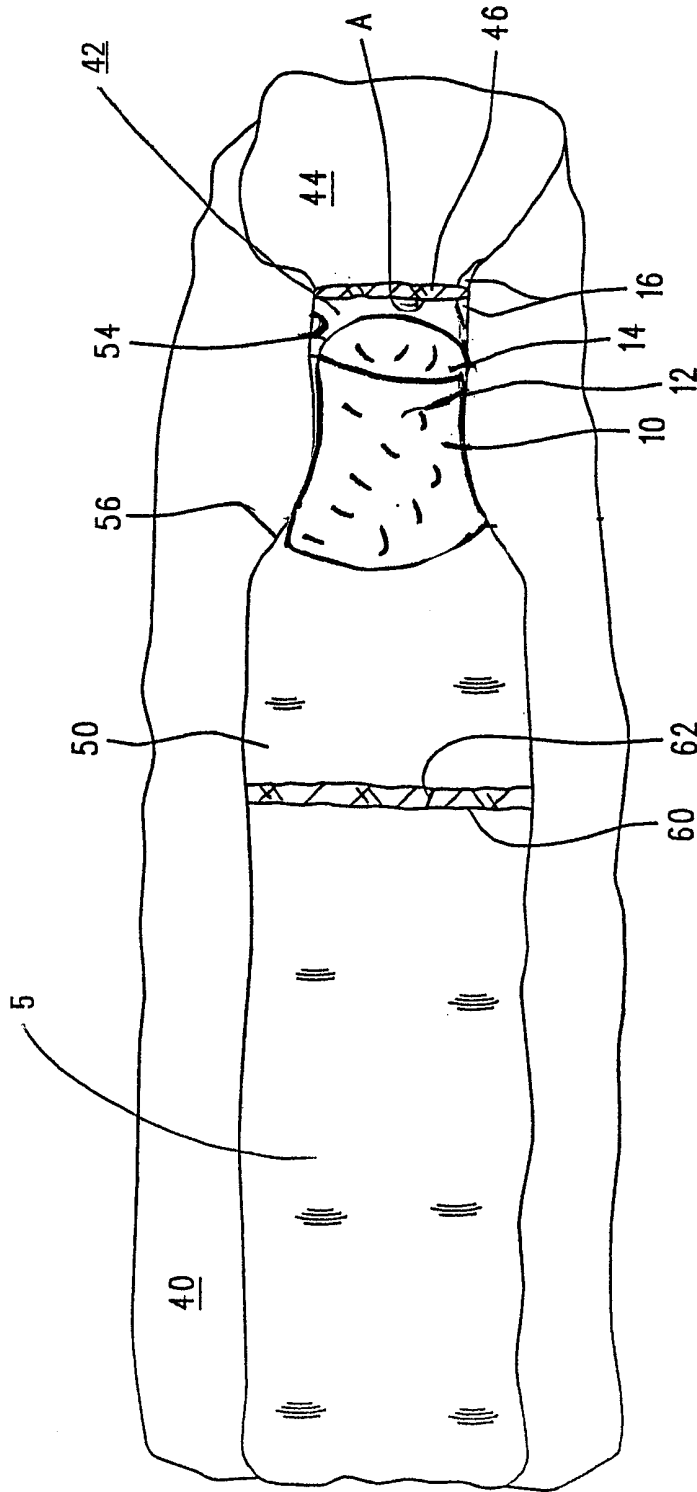

FIG. 4

4/7

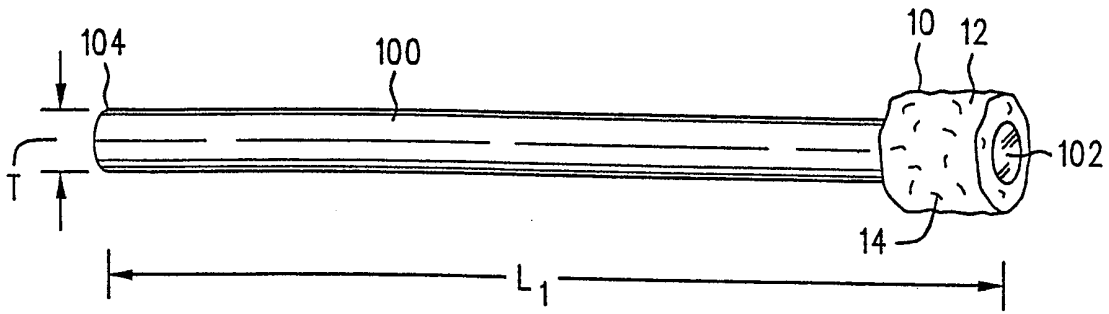

FIG. 5

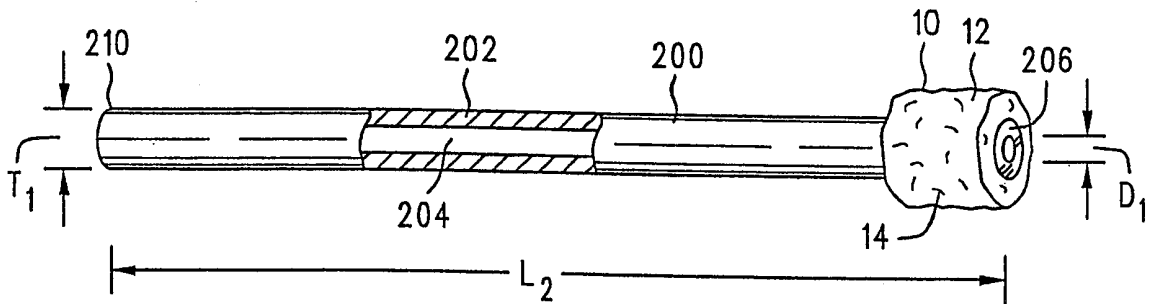

FIG. 6A

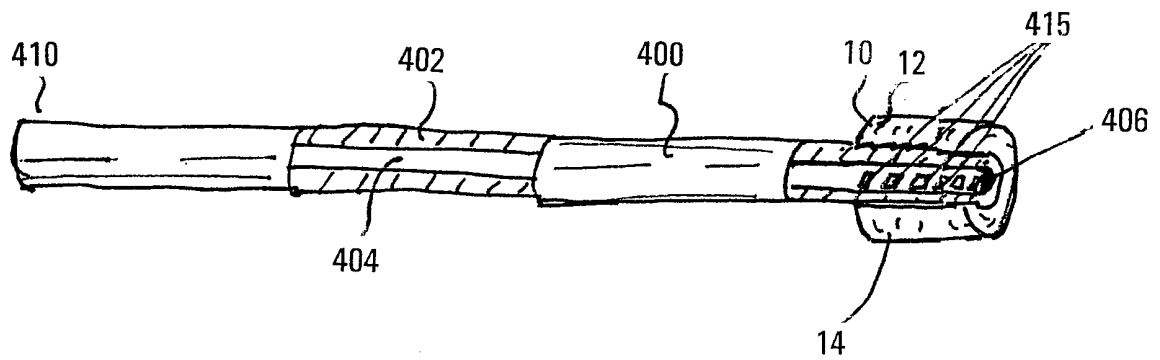

FIG. 6B

5/7

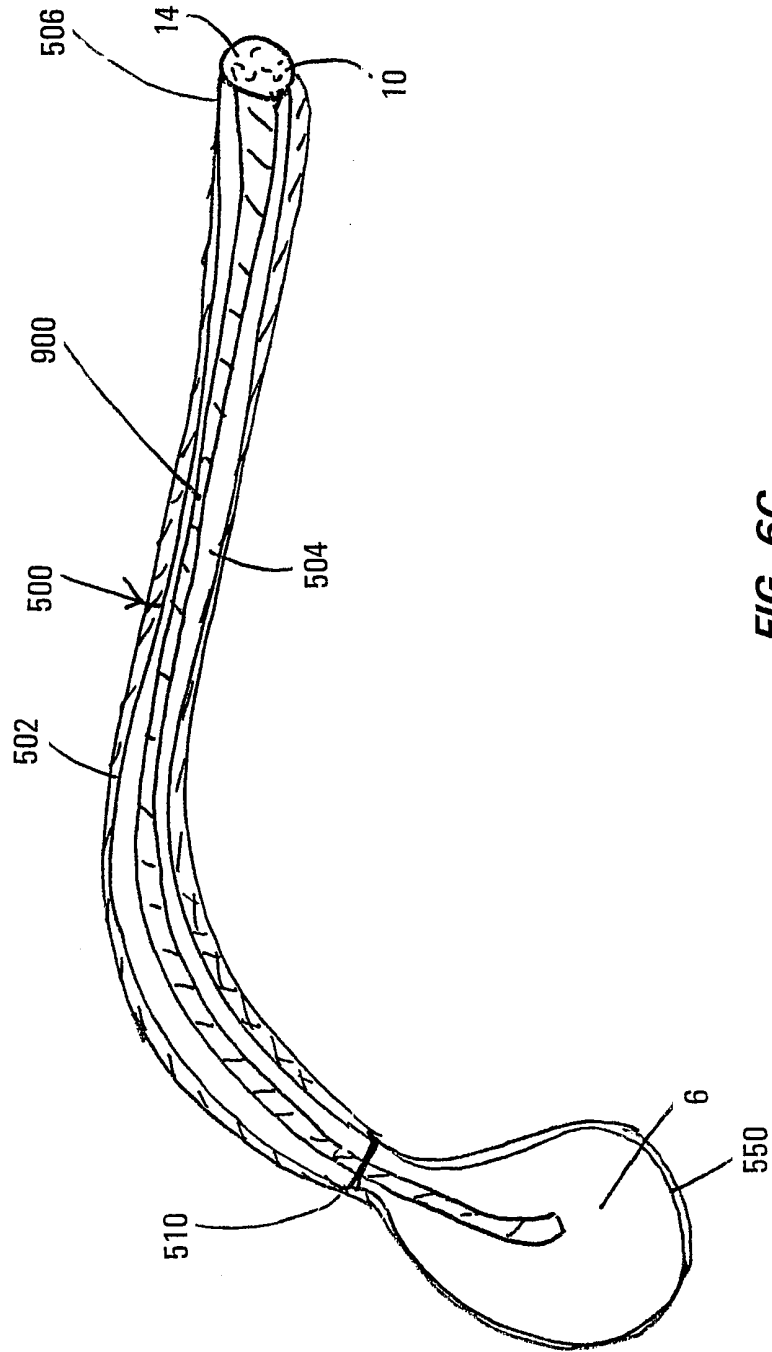
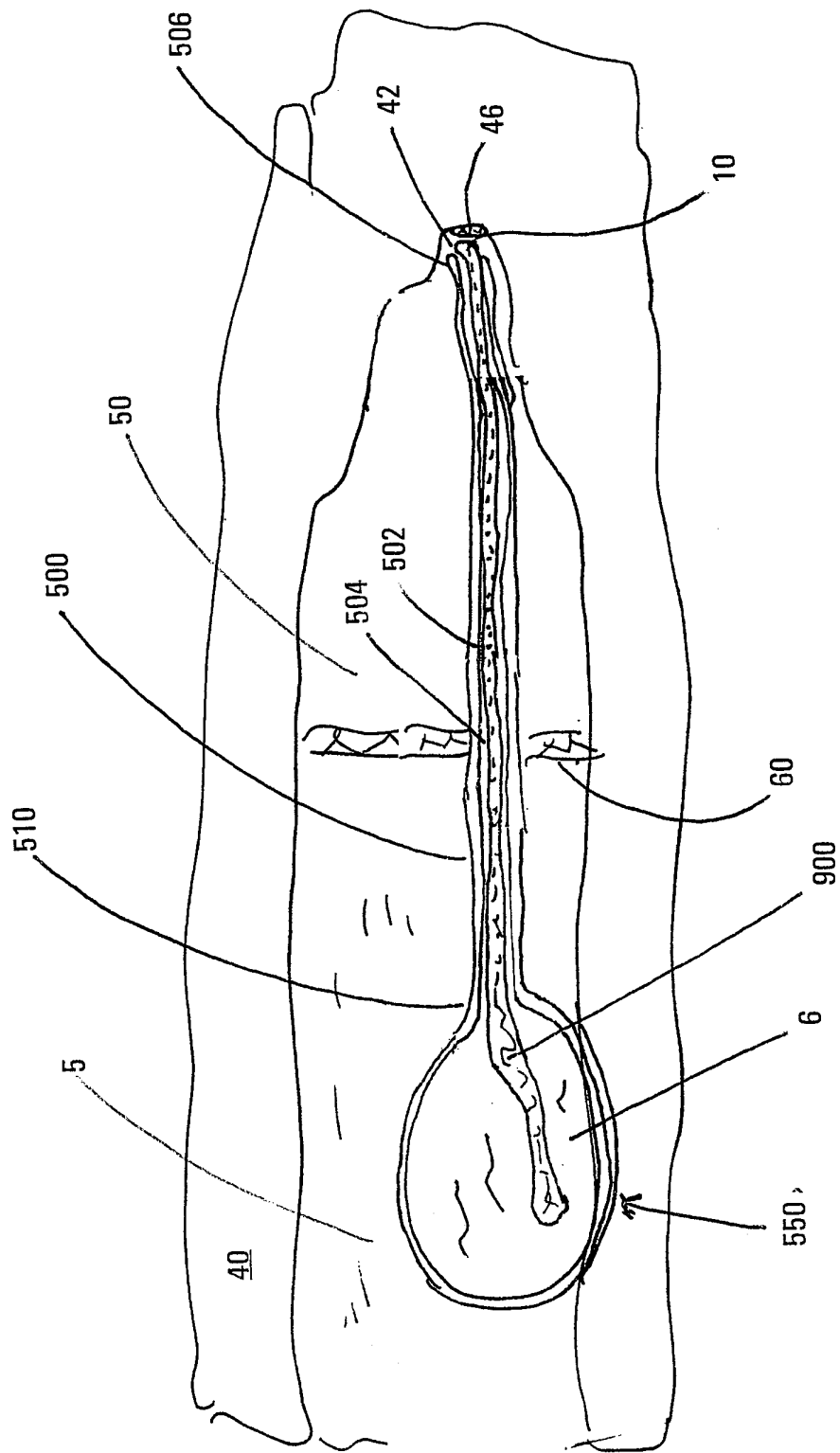

FIG. 6C

FIG. 6D



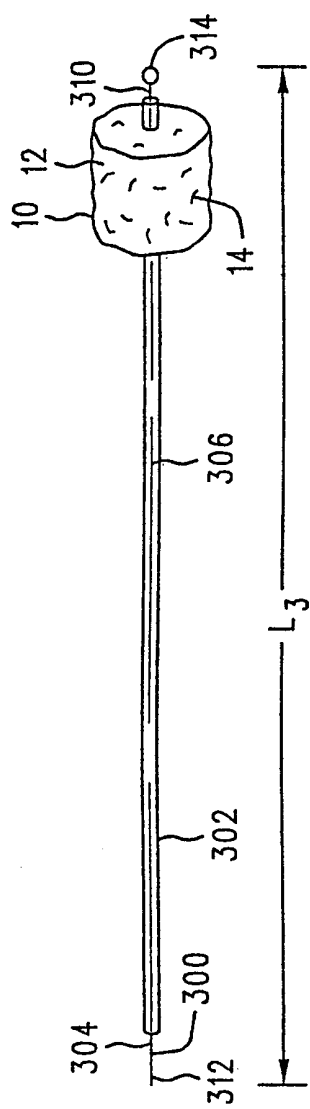

FIG. 7

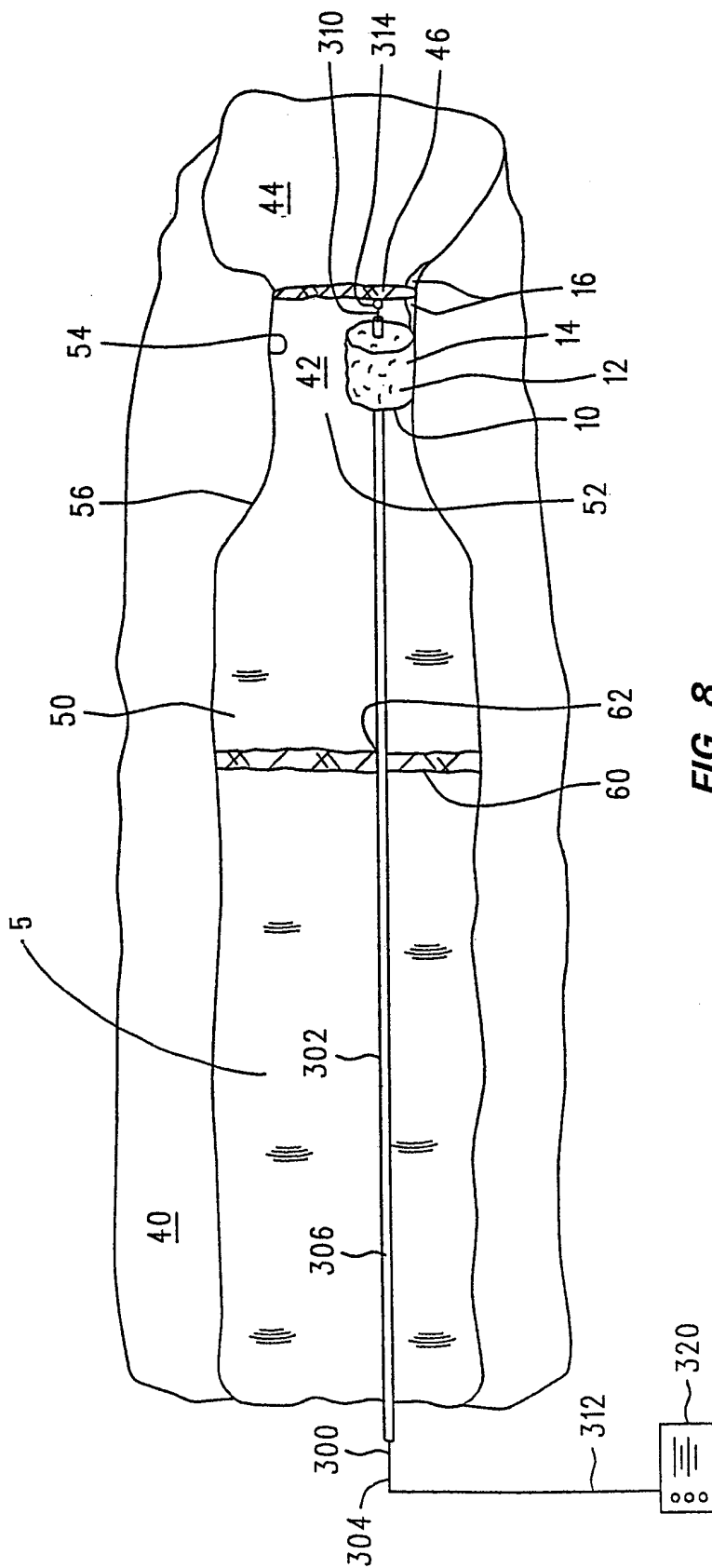

FIG. 8

INTERNATIONAL SEARCH REPORT

International Application No

PCT/US 99/28716

A. CLASSIFICATION OF SUBJECT MATTER
 IPC 7 A61F11/00 A61K9/00

According to International Patent Classification (IPC) or to both national classification and IPC

B. FIELDS SEARCHED

Minimum documentation searched (classification system followed by classification symbols)

IPC 7 A61F A61K

Documentation searched other than minimum documentation to the extent that such documents are included in the fields searched

Electronic data base consulted during the international search (name of data base and, where practical, search terms used)

C. DOCUMENTS CONSIDERED TO BE RELEVANT

| Category ° | Citation of document, with indication, where appropriate, of the relevant passages | Relevant to claim No. |
|------------|---|-----------------------|
| X | WO 97 38698 A (SHEFTER ELI ;HART MICHAEL J (US); MANNING MARK C (US); UNIV TECHNO) 23 October 1997 (1997-10-23) | 1-8 |
| Y | abstract page 5, line 16 -page 6, line 30 claims 1,2 | 9-13 |
| P,X | US 5 954 682 A (PETRUS EDWARD J) 21 September 1999 (1999-09-21) column 3, line 13 - line 27 column 3, line 62 -column 4, line 23 column 6, line 25 -column 7, line 6 claims 2,11 figures 1-6 | 14-18, 20-22 |

Further documents are listed in the continuation of box C.

Patent family members are listed in annex.

° Special categories of cited documents :

- "A" document defining the general state of the art which is not considered to be of particular relevance
- "E" earlier document but published on or after the international filing date
- "L" document which may throw doubts on priority claim(s) or which is cited to establish the publication date of another citation or other special reason (as specified)
- "O" document referring to an oral disclosure, use, exhibition or other means
- "P" document published prior to the international filing date but later than the priority date claimed

- "T" later document published after the international filing date or priority date and not in conflict with the application but cited to understand the principle or theory underlying the invention
- "X" document of particular relevance; the claimed invention cannot be considered novel or cannot be considered to involve an inventive step when the document is taken alone
- "Y" document of particular relevance; the claimed invention cannot be considered to involve an inventive step when the document is combined with one or more other such documents, such combination being obvious to a person skilled in the art.
- "&" document member of the same patent family

Date of the actual completion of the international search

6 April 2000

Date of mailing of the international search report

13/04/2000

Name and mailing address of the ISA

European Patent Office, P.B. 5818 Patentlaan 2
 NL - 2280 HV Rijswijk
 Tel. (+31-70) 340-2040, Tx. 31 651 epo nl,
 Fax: (+31-70) 340-3016

Authorized officer

Muller, S

INTERNATIONAL SEARCH REPORT

International Application No
PCT/US 99/28716

| C.(Continuation) DOCUMENTS CONSIDERED TO BE RELEVANT | | |
|--|---|-----------------------|
| Category ° | Citation of document, with indication, where appropriate, of the relevant passages | Relevant to claim No. |
| Y | <p>US 5 476 446 A (ARENBERG IRVING K) 19 December 1995 (1995-12-19) cited in the application abstract column 3, line 30 -column 4, line 38 column 19, line 25 - line 37 claim 11</p> <p style="text-align: center;">---</p> | 9-13 |
| A | <p>DE 195 08 029 A (SUEVERKRUEP RICHARD PROF DR ;GRUNTHAL SABINE (DE); DIESTELHORST MI) 12 September 1996 (1996-09-12) page 3, line 43 - line 57 claims 1,18,19</p> <p style="text-align: center;">-----</p> | |

INTERNATIONAL SEARCH REPORT

International application No.

PCT/US 99/ 28716

Box I Observations where certain claims were found unsearchable (Continuation of item 1 of first sheet)

This International Search Report has not been established in respect of certain claims under Article 17(2)(a) for the following reasons:

1. Claims Nos.:
because they relate to subject matter not required to be searched by this Authority, namely:
Remark: Although claims 1-13 are directed to a method of treatment of the human/animal body, the search has been carried out and based on the alleged effects of the drug delivery apparatus.
2. Claims Nos.:
because they relate to parts of the International Application that do not comply with the prescribed requirements to such an extent that no meaningful International Search can be carried out, specifically:
3. Claims Nos.:
because they are dependent claims and are not drafted in accordance with the second and third sentences of Rule 6.4(a).

Box II Observations where unity of invention is lacking (Continuation of item 2 of first sheet)

This International Searching Authority found multiple inventions in this International application, as follows:

1. As all required additional search fees were timely paid by the applicant, this International Search Report covers all searchable claims.
2. As all searchable claims could be searched without effort justifying an additional fee, this Authority did not invite payment of any additional fee.
3. As only some of the required additional search fees were timely paid by the applicant, this International Search Report covers only those claims for which fees were paid, specifically claims Nos.:
4. No required additional search fees were timely paid by the applicant. Consequently, this International Search Report is restricted to the invention first mentioned in the claims; it is covered by claims Nos.:

Remark on Protest

- The additional search fees were accompanied by the applicant's protest.
- No protest accompanied the payment of additional search fees.

INTERNATIONAL SEARCH REPORT

Information on patent family members

International Application No
PCT/US 99/28716

| Patent document cited in search report | A | Publication date | Patent family member(s) | Publication date |
|--|---|------------------|---|--|
| WO 9738698 | A | 23-10-1997 | AU 2676397 A | 07-11-1997 |
| US 5954682 | A | 21-09-1999 | NONE | |
| US 5476446 | A | 19-12-1995 | US 5421818 A AU 682908 B AU 8081794 A CA 2173755 A EP 0724408 A WO 9510984 A US 5474529 A | 06-06-1995 23-10-1997 08-05-1995 27-04-1995 07-08-1996 27-04-1995 12-12-1995 |
| DE 19508029 | A | 12-09-1996 | AU 5103196 A CA 2211888 A DE 19549506 C WO 9627350 A EP 0813399 A | 23-09-1996 12-09-1996 30-07-1998 12-09-1996 29-12-1997 |