



US00D734403S

(12) **United States Design Patent**
Womack

(10) **Patent No.:** **US D734,403 S**

(45) **Date of Patent:** **** Jul. 14, 2015**

- (54) **TOY VEHICLE TRACK PORTION**
- (71) Applicant: **Mattel, Inc.**, El Segundo, CA (US)
- (72) Inventor: **Dustee Womack**, Los Angeles, CA (US)
- (73) Assignee: **Mattel, Inc.**, El Segundo, CA (US)
- (**) Term: **14 Years**
- (21) Appl. No.: **29/491,494**

- (22) Filed: **May 21, 2014**
- (51) **LOC (10) Cl.** **21-01**
- (52) **U.S. Cl.**
USPC **D21/565**
- (58) **Field of Classification Search**
USPC D21/484, 490, 493, 509, 564, 565, 802,
D21/818, 821; 446/168-174, 84, 89, 108,
446/112, 114, 116, 124-128, 429,
446/444-447; 463/58-69; 238/10 R,
238/10 A-10 C, 10 E, 10 F; 104/60, 69
CPC A63F 7/00; A63F 7/3622; A63F 2007/28;
A63F 2007/282; A63F 2007/284; A63F
2007/3662
See application file for complete search history.

(56) **References Cited**

U.S. PATENT DOCUMENTS

D261,018	S	9/1981	Vandenbrink	
4,941,611	A	7/1990	Arsenault	
4,953,785	A *	9/1990	Keska	238/10 A
6,695,219	B1	2/2004	Fowler, Sr. et al.	

(Continued)

FOREIGN PATENT DOCUMENTS

DE	19544306	C1	5/1997	
DE	29704437	U1	5/1997	

(Continued)

OTHER PUBLICATIONS

Admitted Prior Art, Tyco Racing 15" Jump Receiving Track Replacement, www.ebay.com/itm/Tyco-Racing-15-Jump-Receiving-Track-

Replacement-/2713572462352?pt=Slot_Cars
&hash=item3f2e26fb1b, 2 pages (undated).
Admitted Prior Art, HUGE Tyco Lot of Over 75 Pieces of Slot Car Race Track & Accessories, www.ebay.com/itm/HUGE-Lot-of-Over-75-Pieces-of-Slot-Car-Race-Track-Accessories-/271369341804?pt=Slot_Cars&hash=item3f2edf8b6c, 2 pages (undated).
Admitted Prior Art, 1980's Tyco Cliff Hangers Slot Car Track Boxed Set, www.etsy.com/listing/103485988/1980s-tyco-cliff-hangers-slot-car-track, 2 pages (undated).

Primary Examiner — Cynthia M Chin
(74) *Attorney, Agent, or Firm* — Edell, Shapiro & Finnan, LLC

(57) **CLAIM**
The ornamental design for a toy vehicle track portion, as shown and described.

DESCRIPTION

FIG. 1 is a top perspective view of a toy vehicle track portion according to an embodiment of the present invention; FIG. 2 is a bottom perspective view of the toy vehicle track portion of FIG. 1; FIG. 3 is a top view of the toy vehicle track portion of FIG. 1; FIG. 4 is a bottom view of the toy vehicle track portion of FIG. 1; FIG. 5 is a right side view of the toy vehicle track portion of FIG. 1; FIG. 6 is a left side view of the toy vehicle track portion of FIG. 1; FIG. 7 is a front view of toy vehicle track portion of FIG. 1; FIG. 8 is a rear view of the toy vehicle track portion of FIG. 1; and, FIG. 9 is a top view of a first toy vehicle track portion of FIG. 1 engaging a second toy vehicle track portion in accordance with FIG. 1.
The broken lines shown in the figures are included for the purpose of illustrating the unclaimed portions of the article and form no part of the claimed design.

1 Claim, 5 Drawing Sheets

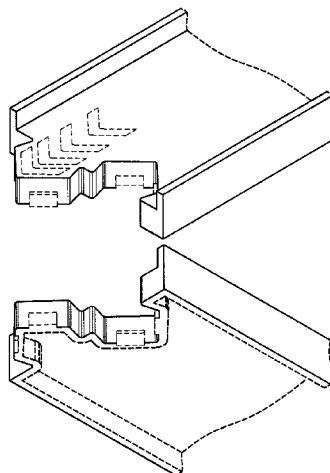

US D734,403 S

Page 2

(56)

References Cited

U.S. PATENT DOCUMENTS

6,883,719 B2 4/2005 Pyrce
D573,665 S * 7/2008 Horikoshi D21/565
D576,690 S 9/2008 Riley
D644,697 S * 9/2011 Mimlitch et al. D21/565
D644,699 S * 9/2011 Mimlitch et al. D21/565
8,567,690 B2 10/2013 De La Torre
2003/0089789 A1 * 5/2003 Rothkopf et al. 238/10 E

2004/0084545 A1 * 5/2004 Pyrce 238/10 A
2005/0247800 A1 11/2005 Pyrce
2012/0129424 A1 5/2012 Payne
2012/0322342 A1 * 12/2012 De La Torre 446/444

FOREIGN PATENT DOCUMENTS

FR 2748218 A1 11/1997
GB 2236957 A 4/1991

* cited by examiner

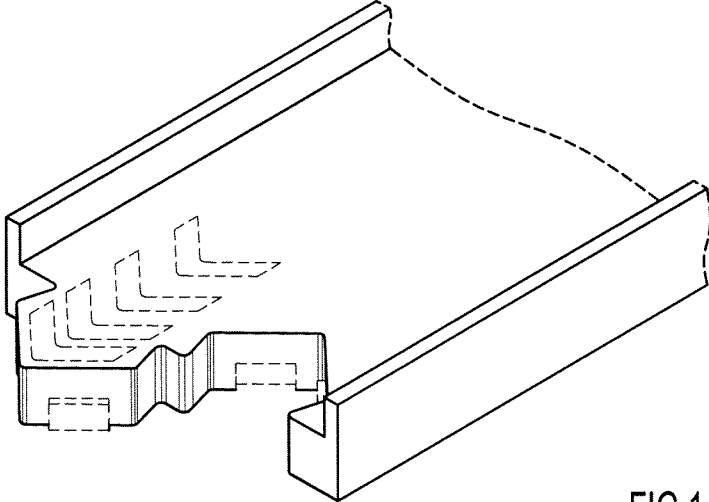

FIG.1

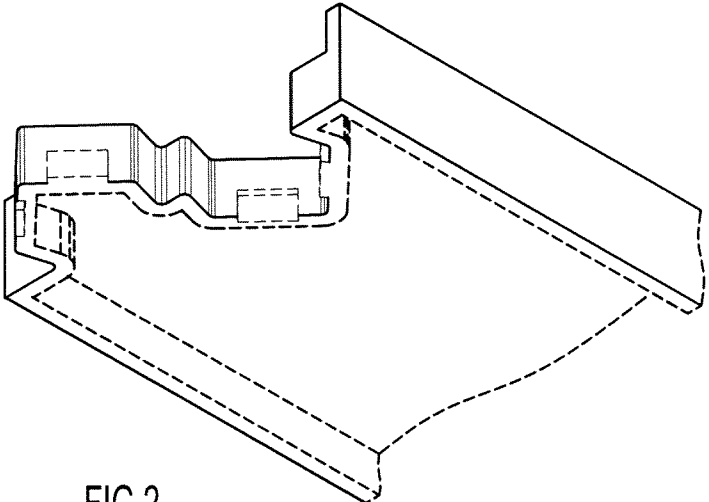

FIG.2

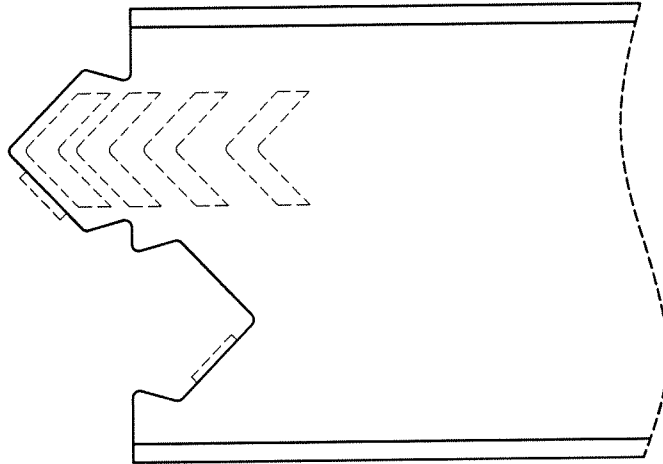

FIG.3

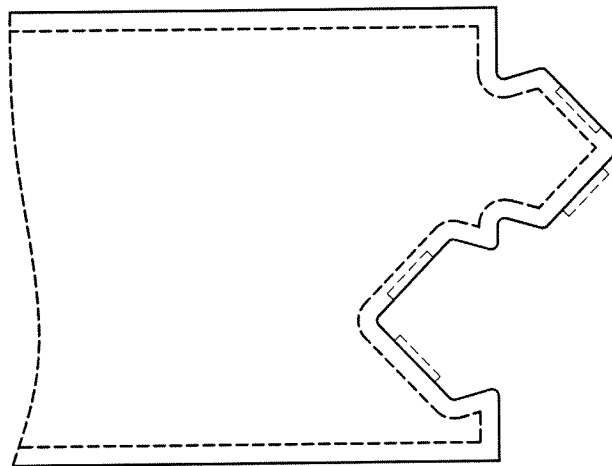

FIG.4

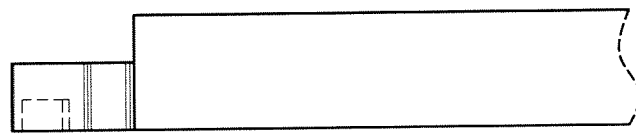

FIG. 5

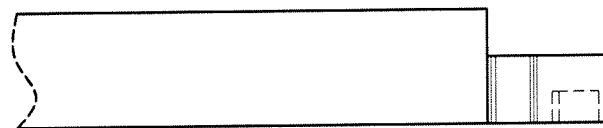

FIG. 6



FIG. 7

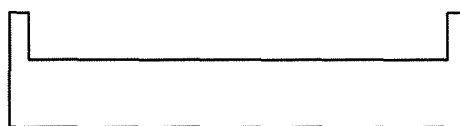

FIG. 8

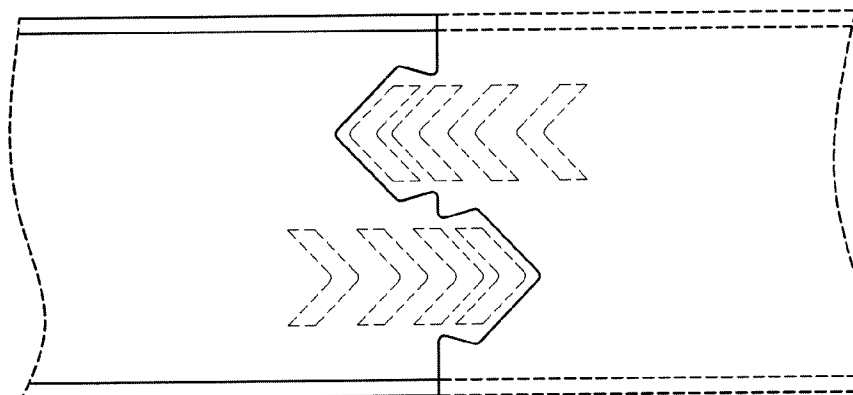

FIG.9