

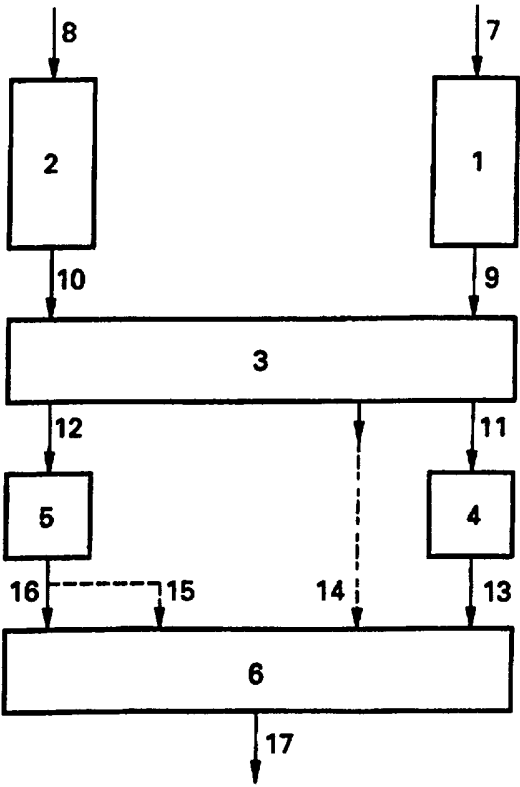

## INTERNATIONAL APPLICATION PUBLISHED UNDER THE PATENT COOPERATION TREATY (PCT)

<p>(51) International Patent Classification <sup>6</sup> : <b>G10L 5/00</b></p>	<p><b>A1</b></p>	<p>(11) International Publication Number: <b>WO 97/44779</b> (43) International Publication Date: 27 November 1997 (27.11.97)</p>
<p>(21) International Application Number: PCT/EP97/02712 (22) International Filing Date: 16 May 1997 (16.05.97) (30) Priority Data: 96201348.8 21 May 1996 (21.05.96) EP (34) Countries for which the regional or international application was filed: NL et al. (71) Applicant (for all designated States except US): KONINKIJE PTT NEDERLAND N.V. [NL/NL]; 7 Stationsplein, NL-9726 AE Groningen (NL). (72) Inventor; and (75) Inventor/Applicant (for US only): BEERENDS, John, Gerard [NL/NL]; Kikkerstraat 20, NL-2515 NB The Hague (NL). (74) Agent: BAAS, Gerardus, Johannes; Koninklijke PTT Nederland N.V., P.O. Box 95321, NL-2509 The Hague (NL).</p>		<p>(81) Designated States: AL, AM, AU, BA, BB, BG, BR, CA, CN, CU, CZ, GE, HU, IL, IS, JP, KE, KG, KP, KR, LC, LK, LR, LV, MD, MG, MK, MN, MW, MX, NO, NZ, PL, RO, RU, SD, SG, SI, SK, TJ, TM, TR, TT, UA, UG, US, UZ, VN, ARIPO patent (GH, KE, LS, MW, SD, SZ, UG), Eurasian patent (AM, AZ, BY, KG, KZ, MD, RU, TJ, TM), European patent (AT, BE, CH, DE, DK, ES, FI, FR, GB, GR, IE, IT, LU, MC, NL, PT, SE), OAPI patent (BF, BJ, CF, CG, CI, CM, GA, GN, ML, MR, NE, SN, TD, TG).</p> <p><b>Published</b> With international search report.</p>
<p>(54) Title: DEVICE FOR DETERMINING THE QUALITY OF AN OUTPUT SIGNAL TO BE GENERATED BY A SIGNAL PROCESSING CIRCUIT, AND ALSO METHOD</p>		
<p>(57) Abstract</p> <p>A device for determining the quality of an output signal originating from a signal processing circuit is provided with a first series circuit for receiving the output signal and with a second series circuit for receiving a reference signal and generates an objective quality signal by means of a combining circuit coupled to the two series circuits. The poor correlation between said objective quality signal and a subjective quality signal can be improved by inside the combining circuit comparing a differential signal which has been integrated with respect to frequency with a predefined value and then in dependence of a comparison result integrating it with respect to time or not, and/or comparing a quality signal associated with a left channel with a quality signal associated with a right channel and selecting the quality signal having the largest value and modifying it in dependence of integrated differential signals.</p> 		

**FOR THE PURPOSES OF INFORMATION ONLY**

Codes used to identify States party to the PCT on the front pages of pamphlets publishing international applications under the PCT.

<b>AL</b>	Albania	<b>ES</b>	Spain	<b>LS</b>	Lesotho	<b>SI</b>	Slovenia
<b>AM</b>	Armenia	<b>FI</b>	Finland	<b>LT</b>	Lithuania	<b>SK</b>	Slovakia
<b>AT</b>	Austria	<b>FR</b>	France	<b>LU</b>	Luxembourg	<b>SN</b>	Senegal
<b>AU</b>	Australia	<b>GA</b>	Gabon	<b>LV</b>	Latvia	<b>SZ</b>	Swaziland
<b>AZ</b>	Azerbaijan	<b>GB</b>	United Kingdom	<b>MC</b>	Monaco	<b>TD</b>	Chad
<b>BA</b>	Bosnia and Herzegovina	<b>GE</b>	Georgia	<b>MD</b>	Republic of Moldova	<b>TG</b>	Togo
<b>BB</b>	Barbados	<b>GH</b>	Ghana	<b>MG</b>	Madagascar	<b>TJ</b>	Tajikistan
<b>BE</b>	Belgium	<b>GN</b>	Guinea	<b>MK</b>	The former Yugoslav Republic of Macedonia	<b>TM</b>	Turkmenistan
<b>BF</b>	Burkina Faso	<b>GR</b>	Greece	<b>ML</b>	Mali	<b>TR</b>	Turkey
<b>BG</b>	Bulgaria	<b>HU</b>	Hungary	<b>MN</b>	Mongolia	<b>TT</b>	Trinidad and Tobago
<b>BJ</b>	Benin	<b>IE</b>	Ireland	<b>MR</b>	Mauritania	<b>UA</b>	Ukraine
<b>BR</b>	Brazil	<b>IL</b>	Israel	<b>MW</b>	Malawi	<b>UG</b>	Uganda
<b>BY</b>	Belarus	<b>IS</b>	Iceland	<b>MX</b>	Mexico	<b>US</b>	United States of America
<b>CA</b>	Canada	<b>IT</b>	Italy	<b>NE</b>	Niger	<b>UZ</b>	Uzbekistan
<b>CF</b>	Central African Republic	<b>JP</b>	Japan	<b>NL</b>	Netherlands	<b>VN</b>	Viet Nam
<b>CG</b>	Congo	<b>KE</b>	Kenya	<b>NO</b>	Norway	<b>YU</b>	Yugoslavia
<b>CH</b>	Switzerland	<b>KG</b>	Kyrgyzstan	<b>NZ</b>	New Zealand	<b>ZW</b>	Zimbabwe
<b>CI</b>	Côte d'Ivoire	<b>KP</b>	Democratic People's Republic of Korea	<b>PL</b>	Poland		
<b>CM</b>	Cameroon	<b>KR</b>	Republic of Korea	<b>PT</b>	Portugal		
<b>CN</b>	China	<b>KZ</b>	Kazakstan	<b>RO</b>	Romania		
<b>CU</b>	Cuba	<b>LC</b>	Saint Lucia	<b>RU</b>	Russian Federation		
<b>CZ</b>	Czech Republic	<b>LI</b>	Liechtenstein	<b>SD</b>	Sudan		
<b>DE</b>	Germany	<b>LK</b>	Sri Lanka	<b>SE</b>	Sweden		
<b>DK</b>	Denmark	<b>LR</b>	Liberia	<b>SG</b>	Singapore		
<b>EE</b>	Estonia						

Titel: Device for determining the quality of an output signal to be generated by a signal processing circuit, and also method

**A Background of the invention**

The invention relates to a device for determining the quality of an output signal to be generated by a signal processing circuit with respect to a reference signal, which device is provided with a first series circuit having a first input for receiving the output signal and is provided with a second series circuit having a second input for receiving the reference signal and is provided with a combining circuit, coupled to a first output of the first series circuit and to a second output of the second series circuit, for generating a quality signal, which first series circuit is provided with

- a first signal processing arrangement, coupled to the first input of the first series circuit, for generating a first signal parameter as a function of time and frequency, and
- a first compressing arrangement, coupled to the first signal processing arrangement, for compressing a first signal parameter and for generating a first compressed signal parameter, which second series circuit is provided with
  - a second compressing arrangement, coupled to the second input, for generating a second compressed signal parameter, which combining circuit is provided with
    - a differential arrangement, coupled to the two compressing arrangements, for determining a differential signal on the basis of the compressed signal parameters,
    - an integrating arrangement, coupled to the differential arrangement, for integrating the differential signal with respect to frequency, and
    - a time-averaging arrangement, coupled to the integrating arrangement, for generating the quality signal by integrating the integrated differential signal with respect to time.

Such a device is disclosed in the first reference: J. Audio Eng. Soc., Vol. 40, No. 12, December 1992, in particular "A Perceptual Audio Quality Measure Based on a Psychoacoustic Sound Representation" by John G. Beerends and Jan A. Stemerding, pages 963 - 978, more particularly Figure 7. The device described therein determines the quality of an output signal to be generated by a signal processing

circuit, such as, for example, a coder/decoder, or codec, with respect to a reference signal. Said reference signal is, for example, an input signal to be presented to the signal processing circuit, although the possibilities also include using as reference signal a pre-calculated ideal version of the output signal. The first signal parameter is generated as a function of time and frequency by means of the first signal processing arrangement, associated with the first series circuit, in response to the output signal, after which the first signal parameter is compressed by means of the first compressing arrangement associated with the first series circuit. In this connection, intermediate operational processing of said first signal parameter should not be ruled out at all. The second signal parameter is compressed by means of the second compressing arrangement associated with the second series circuit in response to the reference signal. In this connection, too, further operational processing of said second signal parameter should not be ruled out at all. Of both compressed signal parameters the differential signal is determined by means of the differential arrangement associated with the combining circuit, after which the quality signal is generated by integrating the differential signal with respect to frequency by means of the integrating arrangement associated with the combining circuit and by then integrating the integrated differential signal with respect to time by means of the time-averaging arrangement associated with the combining circuit.

Such a device has, inter alia, the disadvantage that the objective quality signal to be assessed by means of said device and a subjective quality signal to be assessed by human observers have a poor correlation.

### 30 B Summary of the invention

The object of the invention is, inter alia, to provide a device of the type mentioned in the preamble, the objective quality signal to be assessed by means of said device and a subjective quality signal to be assessed by human observers having a better correlation.

35 For this purpose, the device according to the invention has the characteristic that the combining circuit comprises

- a comparing arrangement for comparing at least one of said signals with an other signal, and

- a selecting arrangement for, in dependence of the comparison result, making a selection.

As a result of providing the device with the comparing arrangement and the selecting arrangement, more relevant signals can  
5 be distinguished from less relevant signals. Due to said comparing and selecting, a good correlation is obtained between the objective quality signal to be assessed by means of said device and a subjective quality signal to be assessed by human observers.

The invention is based, inter alia, on the insight that the poor  
10 correlation between objective quality signals to be assessed by means of known devices and subjective quality signals to be assessed by human observers is the consequence, inter alia, of the fact that certain distortions are found to be more objectionable by human  
observers than other distortions, and is further based, inter alia, on  
15 the insight that, inside the combining circuit, some (time-intervals of) signals are more relevant than other (time-intervals of) signals.

The problem of the poor correlation is thus solved by distinguishing more relevant signals from less relevant signals.

A first embodiment of the device according to the invention has  
20 the characteristic that the comparing arrangement and the selecting arrangement are situated between the integrating arrangement and the time-averaging arrangement for comparing, per time-interval, the integrated differential signal with the other signal having a predefined value and for in case the integrated differential signal  
25 being larger than the other signal supplying the integrated differential signal to the time-averaging arrangement and for in case the integrated differential signal being smaller than the other signal not supplying the integrated differential signal to the time-averaging arrangement.

30 As a result of placing the comparing arrangement and the selecting arrangement between the integrating arrangement and the time-averaging arrangement, per time-interval, the integrated differential signal can be compared with the other signal having a predefined value. By supplying the integrated differential signal to  
35 the time-averaging arrangement in case the integrated differential signal is larger than the other signal and not supplying the integrated differential signal to the time-averaging arrangement in case the integrated differential signal is smaller than the other

signal, the greater relevance of integrated differential signals having a relative high value is stressed.

5 Instead of supplying or not supplying, respectively, an integrated differential signal to the time-averaging arrangement, it would also be possible to, for example, multiply an integrated differential signal with a large number or a small number, respectively, etc., to stress the greater relevance of certain signals.

10 A second embodiment of the device according to the invention has the characteristic that the comparing arrangement and the selecting arrangement are coupled to an output of the time-averaging arrangement for comparing a quality signal associated with a left channel of the signal processing circuit with a quality signal associated with a right channel of the signal processing circuit and for selecting the  
15 quality signal having the largest value.

By placing the comparing arrangement and the selecting arrangement in series with an output of the time-averaging arrangement, a quality signal associated with a left channel of the signal processing circuit can be compared with a quality signal  
20 associated with a right channel of the signal processing circuit and the quality signal having the largest value can be selected. Due to the fact that according to this embodiment the signal processing circuit has got a left and a right channel, two quality signals will have to be determined: one for the left channel, and one for the right  
25 channel. This can be done by either letting the device according to the invention determine the quality of an entire left output signal and then letting said device determine the quality of an entire right output signal, or by, per time-interval, letting said device determine the quality of the left and right output signals.

30 A third embodiment of the device according to the invention has the characteristic that in case the quality signal associated with the right channel being larger than a sum of the quality signal associated with the left channel and a signal having a further predefined value the quality signal associated with the right channel is selected and  
35 in case the quality signal associated with the right channel being smaller than a sum of the quality signal associated with the left channel and the signal having the further predefined value the quality signal associated with the left channel is selected.

Due to the fact that in case the quality signal associated with the right channel being larger than a sum of the quality signal associated with the left channel and a signal having a further predefined value the quality signal associated with the right channel is selected and in case the quality signal associated with the right channel being smaller than a sum of the quality signal associated with the left channel and the signal having the further predefined value the quality signal associated with the left channel is selected, the greater relevance of the left output signal of the signal processing circuit with respect to the right output signal is stressed.

A fourth embodiment of the device according to the invention has the characteristic that the selecting arrangement is provided with a multiplying arrangement for multiplying the selected quality signal with a signal having a value which depends upon at least a correlation between integrated differential signals associated with the left channel and integrated differential signals associated with the right channel.

By providing the selecting arrangement with a multiplying arrangement for multiplying the selected quality signal with a signal having a value which depends upon at least a correlation between integrated differential signals associated with the left channel and integrated differential signals associated with the right channel, a very good correlation is obtained between the objective quality signal to be assessed by means of said device and a subjective quality signal to be assessed by human observers.

Although the first embodiment on the one hand and the second, third and fourth embodiment on the other hand can be regarded to be independent embodiments, the best correlation will be obtained in case the first, second, third and fourth embodiments are used together.

A fifth embodiment of the device according to the invention has the characteristic that the second series circuit is furthermore provided with

- a second signal processing arrangement, coupled to the second input, for generating a second signal parameter as a function of both time and frequency, the second compressing arrangement being coupled to the second signal processing arrangement in order to compress the second signal parameter.

If the second series circuit is furthermore provided with the

second signal processing arrangement, the second signal parameter is generated as a function of both time and frequency. In this case, the input signal to be presented to the signal processing circuit, such as, for example, a coder/decoder, or codec, whose quality is to be determined, is used as reference signal, in contrast to when a second signal processing arrangement is not used, in which case a pre-calculated ideal version of the output signal should be used as reference signal.

A sixth embodiment of the device according to the invention has the characteristic that a signal processing arrangement is provided with

- a multiplying arrangement for multiplying in the time domain a signal to be fed to an input of the signal processing arrangement by a window function, and
- a transforming arrangement, coupled to the multiplying arrangement, for transforming a signal originating from the multiplying arrangement to the frequency domain, which transforming arrangement generates, after determining an absolute value, a signal parameter as a function of time and frequency.

In this connection, the signal parameter is generated as a function of time and frequency by the first and/or second signal processing arrangement as a result of using the multiplying arrangement and the transforming arrangement, which transforming arrangement also performs, for example, the absolute-value determination.

A seventh embodiment of the device according to the invention has the characteristic that a signal processing arrangement is provided with

- a subband filtering arrangement for filtering a signal to be fed to an input of the signal processing arrangement, which subband filtering arrangement generates, after determining an absolute value, a signal parameter as a function of time and frequency.

In this connection, the signal parameter is generated as a function of time and frequency by the first and/or second signal processing arrangement as a result of using the subband filtering arrangement which also performs, for example, the absolute-value

determination.

An eighth embodiment of the device according to the invention has the characteristic that the signal processing arrangement is furthermore provided with

- 5 - a converting arrangement for converting a signal parameter represented by means of a time spectrum and a frequency spectrum into a signal parameter represented by means of a time spectrum and a Bark spectrum.

10 In this connection, the signal parameter generated by the first and/or second signal processing arrangement and represented by means of a time spectrum and a frequency spectrum is converted into a signal parameter represented by means of a time spectrum and a Bark spectrum by using the converting arrangement.

15 The invention furthermore relates to a method for determining the quality of an output signal to be generated by a signal processing circuit with respect to a reference signal, which method comprises the following steps of

- 20 - generating a first signal parameter as a function of time and frequency in response to the output signal,  
- compressing a first signal parameter and generating a second compressed signal parameter,  
- generating a second compressed signal parameter in response to the reference signal,  
- determining a differential signal on the basis of the compressed  
25 signal parameters, and  
- generating a quality signal by integrating the differential signal with respect to frequency and time.

The method according to the invention has the characteristic that the method furthermore comprises the following step of

- 30 - comparing at least one of said signals with an other signal, and making a selection in dependence of the comparison result.

A first embodiment of the method according to the invention has the characteristic that the step of comparing comprises the step of  
35 - comparing, per time-interval, the differential signal which has been integrated with respect to frequency with the other signal having a predefined value and in case the integrated differential signal being larger than the other signal integrating said integrated differential signal with respect to time and in case the differential

signal which has been integrated with respect to frequency being smaller than the other signal not integrating said integrated differential signal with respect to time.

A second embodiment of the method according to the invention has  
5 the characteristic that the step of comparing comprises the steps of  
- comparing a quality signal associated with a left channel of the  
signal processing circuit with a quality signal associated with a  
right channel of the signal processing circuit, and  
- selecting the quality signal having the largest value.

10 A third embodiment of the method according to the invention has  
the characteristic that in case the quality signal associated with the  
right channel being larger than a sum of the quality signal associated  
with the left channel and a signal having a further predefined value  
the quality signal associated with the right channel is selected and  
15 in case the quality signal associated with the right channel being  
smaller than a sum of the quality signal associated with the left  
channel and the signal having the further predefined value the quality  
signal associated with the left channel is selected.

A fourth embodiment of the method according to the invention has  
20 the characteristic that the selected quality signal is multiplied with  
a signal having a value which depends upon at least a correlation  
between differential signals which have been integrated with respect  
to frequency and associated with the left channel and differential  
signals which have been integrated with respect to frequency and  
25 associated with the right channel.

A fifth embodiment of the method according to the invention has  
the characteristic that the step of generating a second compressed  
signal parameter in response to the reference signal comprises the  
following two steps of

30 - generating a second signal parameter in response to the  
reference signal as a function of both time and frequency, and  
- compressing a second signal parameter.

#### C References

- 35 ■ J. Audio Eng. Soc., Vol. 40, No. 12, December 1992, in  
particular, "A Perceptual Audio Quality Measure Based on a  
Psychoacoustic Sound Representation" by John G. Beerends and Jan  
A. Stemerdink, pages 963 - 978

- "Modelling a Cognitive Aspect in the Measurement of the Quality of Music Codecs", by John G. Beerends and Jan A. Stemerdink, presented at the 96th Convention 26 February - 1 March 1994, Amsterdam
- 5 ■ US 4,860,360
- EP 0 627 727
- 10 ■ EP 0 417 739
- DE 37 08 002
- WO EP96 / 01102
- 15 ■ WO EP96 / 01143
- WO EP96 / 00849

20 All the references including the literature cited in these references are deemed to be incorporated in this patent application.

#### D Exemplary embodiment

25 The invention will be explained in greater detail by reference to an exemplary embodiment shown in the figures. In the figures:

Figure 1 shows a device according to the invention, comprising known signal processing arrangements, known compressing arrangements, a scaling circuit, and a combining circuit according to the invention,

30 Figure 2 shows a known signal processing arrangement for use in the device according to the invention,

Figure 3 shows a known compressing arrangement for use in the device according to the invention,

Figure 4 shows a scaling circuit for use in the device according to the invention,

35 Figure 5 shows a first embodiment of a combining circuit according to the invention for use in the device according to the invention, and

Figure 6 shows a second embodiment of a combining circuit

according to the invention for use in the device according to the invention.

The device according to the invention shown in Figure 1 comprises a first signal processing arrangement 1 having a first input 7 for receiving an output signal originating from a signal processing circuit such as, for example, a coder/decoder, or codec. A first output of first signal processing arrangement 1 is connected via a coupling 9 to a first input of a scaling circuit 3. The device according to the invention furthermore comprises a second signal processing arrangement 2 having a second input 8 for receiving an input signal to be fed to the signal processing circuit such as, for example, the coder/decoder, or codec. A second output of second signal processing arrangement 2 is connected via a coupling 10 to a second input of scaling circuit 3. A first output of scaling circuit 3 is connected via a coupling 11 to a first input of a first compressing arrangement 4, and a second output of scaling circuit 3 is connected via a coupling 12 to a second input of a second compressing arrangement 5. A first output of first compressing arrangement 4 is connected via a coupling 13 to a first input of a combining circuit 6, and a second output of second compressing arrangement 5 is connected via a coupling 16 to a second input of combining circuit 6. A third output of scaling circuit 3 is connected via a coupling 14 to a third input of combining circuit 6, and the second output of second compressing arrangement 5, or coupling 16, is connected via a coupling 15 to a fourth input of combining circuit 6 which has an output 17 for generating a quality signal. First signal processing arrangement 1 and first compressing arrangement 4 jointly correspond to a first series circuit, and second signal processing arrangement 2 and second compressing arrangement 5 jointly correspond to a second series circuit.

The known first (or second) signal processing arrangement 1 (or 2) shown in Figure 2 comprises a first (or second) multiplying arrangement 20 for multiplying in the time domain the output signal (or input signal) to be fed to the first input 7 (or second input 8) of the first (or second) signal processing arrangement 1 (or 2) and originating from the signal processing circuit such as, for example, the coder/decoder, or codec, by a window function, a first (or second) transforming arrangement 21, coupled to the first (or second)

5 multiplying arrangement 20, for transforming the signal originating from the first (or second) multiplying arrangement 20 to the frequency domain, a first (or second) absolute-value arrangement 22 for determining the absolute value of the signal originating from the  
10 first (or second) transforming arrangement 21 for generating a first (or second) positive signal parameter as a function of time and frequency, a first (or second) converting arrangement 23 for converting the first (or second) positive signal parameter originating from the first (or second) absolute-value arrangement 22 and  
15 represented by means of a time spectrum and a frequency spectrum into a first (or second) signal parameter represented by means of a time spectrum and a Bark spectrum, and a first (or second) discounting arrangement 24 for discounting a hearing function in the case of the first (or second) signal parameter originating from the first (or second) converting arrangement and represented by means of a time spectrum and a Bark spectrum, which signal parameter is then transmitted via the coupling 9 (or 10).

The known first (or second) compressing arrangement 4 (or 5) shown in Figure 3 receives via coupling 11 (or 12) a signal parameter  
20 which is fed to a first (or second) input of a first (or second) adder 30, a first (or second) output of which is connected via a coupling 31, on the one hand, to a first (or second) input of a first (or second) multiplier 32 and, on the other hand, to a first (or second) nonlinear convoluting arrangement 36 which is furthermore connected to  
25 a first (or second) compressing unit 37 for generating via coupling 13 (or 16) a first (or second) compressed signal parameter. First (or second) multiplier 32 has a further first (or second) input for receiving a feed signal and has a first (or second) output which is connected to a first (or second) input of a first (or second) delay  
30 arrangement 34, a first (or second) output of which is coupled to a further first (or second) input of the first (or second) adder 30.

The scaling circuit 3 shown in Figure 4 comprises a further integrating arrangement 40, a first input of which is connected to the first input of scaling circuit 3 and consequently to coupling 9 for  
35 receiving a first series circuit signal (the first signal parameter represented by means of a time spectrum and a Bark spectrum) and a second input of which is connected to the second input of scaling circuit 3 and consequently to coupling 10 for receiving a second

series circuit signal (the second signal parameter represented by means of a time spectrum and a Bark spectrum). A first output of further integrating arrangement 40 for generating the integrated first series circuit signal is connected to a first input of a further  
5 comparing arrangement 41 and a second output of further integrating arrangement 40 for generating the integrated second series circuit signal is connected to a second input of further comparing arrangement 41. The first input of scaling circuit 3 is connected to the first output and, via scaling circuit 3, coupling 9 is consequently  
10 connected through to coupling 11. The second input of scaling circuit 3 is connected to a first input of a further scaling unit 42 and a second output is connected to an output of further scaling unit 42 and, via scaling circuit 3, coupling 10 is consequently connected through to coupling 12 via further scaling unit 42. An output of  
15 further comparing arrangement 41 for generating a control signal is connected to a control input of further scaling unit 42. The first input of scaling circuit 3, or coupling 9 or coupling 11, is connected to a first input of a ratio-determining arrangement 43 and the output of further scaling unit 42, or coupling 12, is connected to a second  
20 input of ratio-determining arrangement 43, an output of which is connected to the third output of scaling circuit 3 and consequently to coupling 14 for generating a further scaling signal.

The combining circuit 6 shown in Figures 5 and 6 comprises a still further comparing arrangement 50, a first input of which is  
25 connected to the first input of combining circuit 6 for receiving the first compressed signal parameter via coupling 13 and a second input of which is connected to the second input of combining circuit 6 for receiving the second compressed signal parameter via coupling 16. The first input of combining circuit 6 is furthermore connected to a first  
30 input of a differential arrangement 54,56. An output of still further comparing arrangement 50 for generating a scaling signal is connected via a coupling 51 to a control input of scaling arrangement 52, an input of which is connected to the second input of combining circuit 6 for receiving the second compressed signal parameter via coupling 16  
35 and an output of which is connected via a coupling 53 to a second input of differential arrangement 54,56 for determining a differential signal on the basis of the mutually scaled compressed signal parameters. A third input of the differential arrangement 54,56 is

connected to the fourth input of the combining circuit 6 for receiving, via coupling 15, the second compressed signal parameter to be received via coupling 16. Differential arrangement 54,56 comprises a differentiator 54 for generating a differential signal and a further  
5 absolute-value arrangement 56 for determining the absolute value of the differential signal, an output of which is connected to an input of scaling unit 57, a control input of which is connected to the third input of combining circuit 6 for receiving the further scaling signal via coupling 14. An output of scaling unit 57 is connected to an input  
10 of an integrating arrangement 58 for integrating the scaled absolute value of the differential signal with respect to frequency.

According to a first embodiment of combining circuit 6 (Figure 5), an output of integrating arrangement 58 is coupled to an input of selecting arrangement 61 and to a first input of comparing arrangement  
15 60. A second input of comparing arrangement 60 is coupled to a connection 62 for receiving an other signal having a predefined value. An output of comparing arrangement 60 is coupled, via a connection 63, to a control input of selecting arrangement 61. An output of selecting arrangement 61 is coupled to an input of a time-averaging arrangement  
20 59, an output of which is connected to the output 17 of combining circuit 6 for generating the quality signal.

According to a second embodiment of combining circuit 6 (Figure 6), an output of integrating arrangement 58 is coupled to an input of a time-averaging arrangement 59, of which a first output is connected  
25 via a connection 72 to a first input of selecting arrangement 71 and a second output is connected via a connection 73 to a second input of selecting arrangement 71. The output of integrating arrangement 58 is also coupled to a third input of selecting arrangement 71 via a connection 75. The respective first and second outputs of time-averaging arrangement 59 are further coupled via the respective  
30 connections 72 and 73 to respective first and second inputs of comparing arrangement 70, of which an output is coupled via a connection 74 to a control input of selecting arrangement 71, of which an output is connected to the output 17 of combining circuit 6 for  
35 generating the quality signal.

The operation of a standard device for determining the quality of the output signal to be generated by the signal processing circuit such as, for example, the coder/decoder, or codec, which standard

device is formed without the scaling circuit 3 shown in greater detail in Figure 4, the couplings 10 and 12 consequently being mutually connected through, and which known device is formed using a standard combining circuit 6, the third input of differential arrangement 54, 56 and scaling unit 57 and the comparing arrangement 60 and/or 70 and selecting arrangement 61 and/or 71, shown in greater detail in Figures 5 and 6, consequently being missing, is as follows and, indeed, as also described in the first reference.

The output signal of the signal processing circuit such as, for example, the coder/decoder, or codec, is fed to input 7, after which the first signal processing circuit 1 converts said output signal into a first signal parameter represented by means of a time spectrum and a Bark spectrum. This takes place by means of the first multiplying arrangement 20 which multiplies the output signal represented by means of a time spectrum by a window function represented by means of a time spectrum, after which the signal thus obtained and represented by means of a time spectrum is transformed by means of first transforming arrangement 21 to the frequency domain, for example by means of an FFT, or fast Fourier transform, after which the absolute value of the signal thus obtained and represented by means of a time spectrum and a frequency spectrum is determined by means of the first absolute-value arrangement 22, for example by squaring, after which the signal parameter thus obtained and represented by means of a time spectrum and a frequency spectrum is converted by means of first converting arrangement 23 into a signal parameter represented by means of a time spectrum and a Bark spectrum, for example by resampling on the basis of a nonlinear frequency scale, also referred to as Bark scale, which signal parameter is then adjusted by means of first discounting arrangement 24 to a hearing function, or is filtered, for example by multiplying by a characteristic represented by means of a Bark spectrum.

The first signal parameter thus obtained and represented by means of a time spectrum and a Bark spectrum is then converted by means of the first compressing arrangement 4 into a first compressed signal parameter represented by means of a time spectrum and a Bark spectrum. This takes place by means of first adder 30, first multiplier 32 and first delay arrangement 34, the signal parameter represented by means of a time spectrum and a Bark spectrum being

multiplied by a feed signal represented by means of a Bark spectrum such as, for example, an exponentially decreasing signal, after which the signal parameter thus obtained and represented by means of a time spectrum and a Bark spectrum is added, with a delay in time, to the  
5 signal parameter represented by means of a time spectrum and a Bark spectrum, after which the signal parameter thus obtained and represented by means of a time spectrum and a Bark spectrum is convoluted by means of first nonlinear convoluting arrangement 36 with a spreading function represented by means of a Bark spectrum, after  
10 which the signal parameter thus obtained and represented by means of a time spectrum and a Bark spectrum is compressed by means of first compressing unit 37.

In a corresponding manner, the input signal of the signal processing circuit such as, for example, the coder/decoder, or codec,  
15 is fed to input 8, after which the second signal processing circuit 2 converts said input signal into a second signal parameter represented by means of a time spectrum and a Bark spectrum, and the latter is converted by means of the second compressing arrangement 5 into a second compressed signal parameter represented by means of a time  
20 spectrum and a Bark spectrum.

The first and second compressed signal parameters, respectively, are then fed via the respective couplings 13 and 16 to combining circuit 6, it being assumed for the time being that this is a standard  
25 combining circuit which lacks the third input of differential arrangement 54,56 and scaling unit 57 shown in greater detail in Figure 5. The two compressed signal parameters are integrated by still further comparing arrangement 50 and mutually compared, after which still further comparing arrangement 50 generates the scaling signal which represents, for example, the average ratio between the two  
30 compressed signal parameters. Said scaling signal is fed to scaling arrangement 52 which, in response thereto, scales the second compressed signal parameter (that is to say, increases or reduces it as a function of the scaling signal). Obviously, scaling arrangement 52 could also be used, in a manner known to the person skilled in the  
35 art, for scaling the first compressed signal parameter instead of for scaling the second compressed signal parameter and use could furthermore be made, in a manner known to the person skilled in the art, of two scaling arrangements for mutually scaling the two

compressed signal parameters at the same time. The differential signal is derived by means of differentiator 54 from the mutually scaled compressed signal parameters, the absolute value of which differential signal is then determined by means of further absolute-value arrangement 56. The signal thus obtained is integrated by means of integrator 58 with respect to a Bark spectrum and is integrated by means of time-averaging arrangement 59 with respect to a time spectrum and generated by means of output 17 as quality signal which indicates in an objective manner the quality of the signal processing circuit such as, for example, the coder/decoder or codec.

The operation of an improved device for determining the quality of the output signal to be generated by the signal processing circuit such as, for example, the coder/decoder, or codec, which device according to the invention is consequently formed with the scaling circuit 3 shown in greater detail in Figure 4, the couplings 10 and 12 consequently being coupled through mutually via further scaling unit, and which improved device is formed with an expanded combining circuit 6 according to the invention to which the third input of differential arrangement 54,56 shown in greater detail in Figures 5,6 and scaling unit 57 have consequently been added is as described above, supplemented by what follows.

The first series circuit signal (the first signal parameter represented by means of a time spectrum and a Bark spectrum) to be received via coupling 9 and the first input of scaling circuit 3 is fed to the first input of further integrating arrangement 40 and the second series circuit signal (the second signal parameter represented by means of a time spectrum and a Bark spectrum) to be received via the coupling 10 and the second input of scaling circuit 3 is fed to the second input of further integrating arrangement 40, which integrates the two series circuit signals with respect to frequency, after which the integrated first series circuit signal is fed via the first output of further integrating arrangement 40 to the first input of further comparing arrangement 41 and the integrated second series circuit signal is fed via the second output of further integrating arrangement 40 to the second input of further comparing arrangement 41. The latter compares the two integrated series circuit signals and generates, in response thereto, the control signal which is fed to the control input of further scaling unit 42. The latter scales the second

series circuit signal (the second signal parameter represented by means of a time spectrum and a Bark spectrum) to be received via coupling 10 and the second input of scaling circuit 3 as a function of said control signal (that is to say increases or reduces the amplitude of said second series circuit signal) and generates [sic] the thus  
5 scaled second series circuit signal via the output of further scaling unit 42 to the second output of scaling circuit 3, while the first input of scaling arrangement 3 is connected through in this example in a direct manner to the first output of scaling circuit 3. In this  
10 example, the first series circuit signal and the scaled second series circuit signal, respectively are passed via scaling circuit 3 to first compressing arrangement 4 and second compressing arrangement 5, respectively.

As a result of this further scaling, a good correlation is  
15 obtained between the objective quality signal to be assessed by means of the device according to the invention and a subjective quality signal to be assessed by human observers. This invention is based, inter alia, on the insight that the poor correlation between objective quality signals to be assessed by means of known devices and  
20 subjective quality signals to be assessed by human observers is the consequence, inter alia, of the fact that certain distortions are found to be more objectionable by human observers than other distortions, which poor correlation is improved by using the two compressing arrangements, and is furthermore based, inter alia, on the  
25 insight that, as a result of using scaling circuit 3, the two compressing arrangements 4 and 5 function better with respect to one another, which improves the correlation further. The problem of the poor correlation is consequently solved by an improved functioning of the two compressing arrangements 4 and 5 with respect to one another  
30 as a result of using scaling circuit 3.

As a result of the fact that the first input of scaling circuit 3, or coupling 9 or coupling 11, is connected to the first input of ratio-determining arrangement 43 and the output of further scaling unit 42, or coupling 12, is connected to the second input of ratio-  
35 determining arrangement 43, ratio-determining arrangement 43 is capable of assessing the mutual ratio of the first series circuit signal and the scaled second series circuit signal and of generating a further scaling signal as a function thereof by means of the output of

ratio-determining arrangement 43, which further scaling signal is fed via the third output of scaling circuit 3 and consequently via coupling 14 to the third input of combining circuit 6. Said further scaling signal is fed in combining circuit 6 to scaling unit 57 which scales, as a function of said further scaling signal, the absolute value of the differential signal originating from the differential arrangement 54,56 (that is to say increases or reduces the amplitude of said absolute value). As a consequence thereof, the already improved correlation is improved further as a result of the fact an (amplitude) difference still present between the first series circuit signal and the scaled second series circuit signal in the combining circuit is discounted and integrating arrangement 58 and time-averaging arrangement 59 function better as a result.

A further improvement of the correlation is obtained if differentiator 54 (or further absolute-value arrangement 56) is provided with a further adjusting arrangement, not shown in the figures, for example in the form of a subtracting circuit which somewhat reduces the amplitude of the differential signal. Preferably, the amplitude of the differential signal is reduced as a function of a series circuit signal, just as in this example it is reduced as a function of the scaled and compressed second signal parameter originating from second compressing arrangement 5, as a result of which integrating arrangement 58 and time-averaging arrangement 59 function still better. As a result, the already very good correlation is improved still further.

It is observed that ratio-determining arrangement 43 could also be placed between couplings 13 and 16 (in other words between compressing arrangements 4 and 5, on the one hand, and combining circuit 6 on the other hand). In this case, the correlation is improved by using the results of both compressing arrangements 4 and 5 in a better way.

The operation of a device according to the invention for determining the quality of the output signal to be generated by the signal processing circuit such as, for example, the coder/decoder, or codec, which device according to the invention is consequently formed with either at least the first embodiment of the combining circuit 6 shown in greater detail in Figure 5 and comprising comparing arrangement 60 and selecting arrangement 70, or at least the second

embodiment of the combining circuit 6 shown in greater detail in Figure 6 and comprising comparing arrangement 61 and selecting arrangement 71, is as described above, supplemented by what follows.

In case of the first embodiment (Figure 5), the differential  
5 signal which has been integrated with respect to frequency by  
integrating arrangement 58, is supplied to comparing arrangement 60  
and selecting arrangement 61. Comparing arrangement 60 compares, for  
each time-interval of for example 40 msec., a value of said signal  
with an other signal having a predefined value. In case the integrated  
10 differential signal is larger (much distortion) than the other signal,  
comparing arrangement 60 controls selecting arrangement 61 such that  
the integrated differential signal is supplied (or multiplied by a  
large number) to time-averaging arrangement 59. In case the integrated  
differential signal is smaller (little distortion) than the other  
15 signal, comparing arrangement 60 controls selecting arrangement 61  
such that the integrated differential signal is not supplied (or  
multiplied by a small number) to time-averaging arrangement 59. Due to  
this, the greater relevance of (time-intervals of) signals indicating  
much distortion is stressed with respect to (time-intervals of)  
20 signals indicating little distortion, which results in better  
correlation.

In case of the second embodiment (Figure 6), the differential  
signal which has been integrated with respect to frequency by  
integrating arrangement 58, is supplied to time-averaging arrangement  
25 59 and to the third input of selecting arrangement 71. Time-averaging  
arrangement generates two quality signals, a first quality signal  
associated with a left channel of the signal processing circuit, and a  
second quality signal associated with a right channel of the signal  
processing circuit. This can be done by either letting the device  
30 according to the invention determine the quality of an entire left  
output signal and then letting said device determine the quality of an  
entire right output signal, or by, per time-interval (of for example  
10 sec.), letting said device determine the quality of firstly the  
left and secondly the right output signals. To a person skilled in the  
35 art it will be obvious that in at least one of both cases at least  
some of the circuits and/or arrangements will have to be provided with  
memories.

Comparing arrangement 70 compares these two quality signals. In

case the second quality signal associated with the right channel being larger than a sum of the first quality signal associated with the left channel and a signal having a further predefined value the selecting arrangement 71 is controlled such that the second quality signal  
5 associated with the right channel is selected. In case the second quality signal associated with the right channel being smaller than a sum of the first quality signal associated with the left channel and the signal having the further predefined value the selecting arrangement 71 is controlled such that the first quality signal  
10 associated with the left channel is selected. Then, inside selecting arrangement 71, the selected quality signal is multiplied with a signal for example having a value  $(1.2-c)^4$  which depends upon at least a correlation (c) between integrated differential signals associated with the left channel and integrated differential signals associated  
15 with the right channel. Thereto, selecting arrangement 70 comprises for example a multiplying arrangement for multiplying the selected quality signal with said value, and a correlating arrangement for correlating both integrated differential signals, and a memory for storing integrated differential signals. Due to this, the disturbance  
20 of distortions causing binaural image shift is stressed.

The components shown in Figure 2 of first signal processing arrangement 1 are described, as stated earlier, adequately and in a manner known to the person skilled in the art in the first reference. A digital output signal which originates from the signal processing  
25 circuit such as, for example, the coder/decoder, or codec, and which is, for example, discrete both in time and in amplitude is multiplied by means of first multiplying arrangement 20 by a window function such as, for example, a so-called cosine square function represented by means of a time spectrum, after which the signal thus obtained and  
30 represented by means of a time spectrum is transformed by means of first transforming arrangement 21 to the frequency domain, for example by an FFT, or fast Fourier transform, after which the absolute value of the signal thus obtained and represented by means of a time spectrum and a frequency spectrum is determined by means of the first  
35 absolute-value arrangement 22, for example by squaring. Finally, a power density function per time/frequency unit is thus obtained. An alternative way of obtaining said signal is to use a subband filtering arrangement for filtering the digital output signal, which subband

filtering arrangement generates, after determining an absolute value, a signal parameter as a function of time and frequency in the form of the power density function per time/frequency unit. First converting arrangement 23 converts said power density function per time/frequency unit, for example by resampling on the basis of a nonlinear frequency scale, also referred to as Bark scale, into a power density function per time/Bark unit, which conversion is described comprehensively in Appendix A of the first reference, and first discounting arrangement 24 multiplies said power density function per time/Bark unit, for example by a characteristic, represented by means of a Bark spectrum, for performing an adjustment on a hearing function.

The components, shown in Figure 3, of first compressing arrangement 4 are, as stated earlier, described adequately and in a manner known to the person skilled in the art in the first reference. The power density function per time/Bark unit adjusted to a hearing function is multiplied by means of multiplier 32 by an exponentially decreasing signal such as, for example,  $\exp(-T/\tau(z))$ . Here T is equal to 50% of the length of the window function and consequently represents half of a certain time interval, after which certain time interval first multiplying arrangement 20 always multiplies the output signal by a window function represented by means of a time spectrum (for example, 50% of 40 msec is 20 msec). In this expression,  $\tau(z)$  is a characteristic which is represented by means of the Bark spectrum and is shown in detail in Figure 6 of the first reference. First delay arrangement 34 delays the product of this multiplication by a delay time of length T, or half of the certain time interval. First nonlinear convolution arrangement 36 convolutes the signal supplied by a spreading function represented by means of a Bark spectrum, or spreads a power density function represented per time/Bark unit along a Bark scale, which is described comprehensively in Appendix B of the first reference. First compressing unit 37 compresses the signal supplied in the form of a power density function represented per time/Bark unit with a function which, for example, raises the power density function represented per time/Bark unit to the power  $\alpha$ , where  $0 < \alpha < 1$ .

The components, shown in Figure 4, of scaling circuit 3 can be formed in a manner known to the person skilled in the art. Further integrating arrangement 40 comprises, for example, two separate

integrators which separately integrate the two series circuit signals supplied by means of a Bark spectrum, after which further comparing arrangement 41 in the form of, for example, a divider, divides the two integrated signals by one another and feeds the division result or the inverse division result as control signal to further scaling unit 42 which, in the form of, for example, a multiplier or a divider, multiplies or divides the second series circuit signal by the division result or the inverse division result in order to make the two series circuit signals, viewed on average, of equal size. Ratio-determining arrangement 43 receives the first and the scaled second series circuit signal in the form of compressed, spread power density functions represented per time/Bark unit and divides them by one another to generate the further scaling signal in the form of the division result represented per time/Bark unit or the inverse thereof, depending on whether scaling unit 57 is constructed as multiplier or as divider.

The components, shown in Figures 5 and 6, of combining circuit 6 are, as stated earlier, described adequately and in a manner known to the person skilled in the art in the first reference, with the exception of the component 57 and a portion of component 54 and comparing arrangement 60,61 and selecting arrangement 70,71. Still further comparing arrangement 50 comprises, for example, two separate integrators which separately integrate the two series circuit signals supplied over, for example, three separate portions of a Bark spectrum and comprises, for example, a divider which divides the two integrated signals by one another per portion of the Bark spectrum and feeds the division result or the inverse division result as scaling signal to scaling arrangement 52 which, in the form of, for example, a multiplier or a divider, multiplies or divides the respective series circuit signal by the division result or the inverse division result in order to make the two series circuit signals, viewed on average, of equal size per portion of the Bark spectrum. All this is described comprehensively in Appendix F of the first reference. Differentiator 54 determines the difference between the two mutually scaled series circuit signals. According to the improved device, if the difference is negative, said difference can then be augmented by a constant value and, if the difference is positive, said difference can be reduced by a constant value, for example by detecting whether it is less or greater than the value zero and then adding or subtracting the

constant value. It is, however, also possible first to determine the absolute value of the difference by means of further absolute-value arrangement 56 and then to deduct the constant value from said absolute value, in which connection a negative final result must obviously not be permitted to be obtained. In this last case, absolute-value arrangement 56 should be provided with a subtracting circuit. Furthermore, it is possible, according to the improved device, to discount from the difference a (portion of a) series circuit signal in a similar manner instead of the constant value or together with the constant value.

According to the invention (Figure 5) integrating arrangement 58 integrates the signal originating from scaling unit 57 with respect to a Bark spectrum and comparing arrangement 60 compares the value of the integrated differential signal (comprising for example one value per time-interval of 40 msec.) with the predefined value of the other signal arriving via connection 62. In response to the comparison result, selecting arrangement 61 blocks said integrated differential signal or supplies said integrated differential signal to time-averaging arrangement 59 which integrates the signal thus obtained with respect to a time spectrum, as a result of which the quality signal is obtained which has a value which is the smaller, the higher the quality of the signal processing circuit is. So, selecting arrangement 61 could be in the form of a switch, or for example in the form of a multiplier for multiplying said integrated differential signal with a small or a large number.

According to the invention (Figure 6) integrating arrangement 58 integrates the signal originating from scaling unit 57 with respect to a Bark spectrum and time-averaging arrangement 59 integrates the signal thus obtained with respect to a time spectrum, as a result of which the first and second quality signals are obtained which have a value which is the smaller, the higher the quality of the left and right channel of the signal processing circuit is. Comparing arrangement 70 compares both quality signals, and in response to the comparison result selecting means 71 select one of both quality signals. Selecting means 71 comprise a memory for storing integrated differential signals, a correlating arrangement for correlating integrated differential signals associated with the left channel and integrated differential signals associated with the right channel,

resulting in a value  $c$ , a calculating arrangement for calculating the value  $(1.2-c)^4$ , and a multiplying arrangement for multiplying the selected quality signal with said value  $(1.2-c)^4$ .

As already described earlier, the correlation between the objective quality signal to be assessed by means of the device according to the invention and a subjective quality signal to be assessed by human observers is improved by expanding the combining circuit 6 of the device with comparing arrangement 60 and/or 70 and selecting arrangement 61 and/or 71. Two factors can be viewed separately from one another:

- the use of comparing arrangement 60 and selecting arrangement 61, and
- the use of comparing arrangement 70 and selecting arrangement 71.

The best correlation is obtained by simultaneous use of all the possibilities.

The widest meaning should be reserved for the term signal processing circuit, in which connection, for example, all kinds of audio and/or video equipment can be considered. Thus, the signal processing circuit could be a codec, in which case the input signal is the reference signal with respect to which the quality of the output signal should be determined. The signal processing circuit could also be an equalizer, in which connection the quality of the output signal should be determined with respect to a reference signal which is calculated on the basis of an already existing virtually ideal equalizer or is simply calculated. The signal processing circuit could even be a loudspeaker, in which case a smooth output signal could be used as reference signal, with respect to which the quality of a sound output signal is then determined (scaling already takes place automatically in the device according to the invention). The signal processing circuit could furthermore be a loudspeaker computer model which is used to design loudspeakers on the basis of values to be set in the loudspeaker computer model, in which connection a low-volume output signal of said loudspeaker computer model serves as the reference signal and in which connection a high-volume output signal of said loudspeaker computer model then serves as the output signal of the signal processing circuit.

In the case of a calculated reference signal, the second signal

processing arrangement of the second series circuit could be omitted as a result of the fact that the operations to be performed by the second signal processing arrangement can be discounted in calculating the reference signal.

**E Claims**

1. Device for determining the quality of an output signal to be generated by a signal processing circuit with respect to a reference signal, which device is provided with a first series circuit having a first input for receiving the output signal and is provided with a second series circuit having a second input for receiving the reference signal and is provided with a combining circuit, coupled to a first output of the first series circuit and to a second output of the second series circuit, for generating a quality signal, which first series circuit is provided with
- 5
- 10 - a first signal processing arrangement, coupled to the first input of the first series circuit, for generating a first signal parameter as a function of time and frequency, and
  - a first compressing arrangement, coupled to the first signal processing arrangement, for compressing a first signal parameter and for generating a first compressed signal parameter,
  - 15 which second series circuit is provided with
    - a second compressing arrangement, coupled to the second input, for generating a second compressed signal parameter,
    - 20 which combining circuit is provided with
      - a differential arrangement, coupled to the two compressing arrangements, for determining a differential signal on the basis of the compressed signal parameters,
      - an integrating arrangement, coupled to the differential arrangement, for integrating the differential signal with respect to
      - 25 frequency, and
        - a time-averaging arrangement, coupled to the integrating arrangement, for generating the quality signal by integrating the integrated differential signal with respect to time, characterized in that the combining circuit comprises
        - 30 - a comparing arrangement for comparing at least one of said signals with an other signal, and
        - a selecting arrangement for, in dependence of the comparison result, making a selection.
- 35
2. Device according to Claim 1, characterized in that the comparing arrangement and the selecting arrangement are situated between the integrating arrangement and the time-averaging arrangement for

comparing, per time-interval, the integrated differential signal with the other signal having a predefined value and for in case the integrated differential signal being larger than the other signal supplying the integrated differential signal to the time-averaging arrangement and for in case the integrated differential signal being smaller than the other signal not supplying the integrated differential signal to the time-averaging arrangement.

3. Device according to Claim 1, characterized in that the comparing arrangement and the selecting arrangement are coupled to an output of the time-averaging arrangement for comparing a quality signal associated with a left channel of the signal processing circuit with a quality signal associated with a right channel of the signal processing circuit and for selecting the quality signal having the largest value.

4. Device according to Claim 3, characterized in that in case the quality signal associated with the right channel being larger than a sum of the quality signal associated with the left channel and a signal having a further predefined value the quality signal associated with the right channel is selected and in case the quality signal associated with the right channel being smaller than a sum of the quality signal associated with the left channel and the signal having the further predefined value the quality signal associated with the left channel is selected.

5. Device according to Claim 4, characterized in that the selecting arrangement is provided with a multiplying arrangement for multiplying the selected quality signal with a signal having a value which depends upon at least a correlation between integrated differential signals associated with the left channel and integrated differential signals associated with the right channel.

6. Device according to Claim 1, 2, 3, 4 or 5, characterized in that the second series circuit is furthermore provided with a second signal processing arrangement, coupled to the second input, for generating a second signal parameter as a function of both time and frequency, the second compressing arrangement being coupled

to the second signal processing arrangement in order to compress the second signal parameter.

7. Device according to Claim 1, 2, 3, 4, 5 or 6, characterized in  
5 that a signal processing arrangement is provided with  
- a multiplying arrangement for multiplying in the time domain a  
signal to be fed to an input of the signal processing arrangement by a  
window function, and  
- a transforming arrangement, coupled to the multiplying  
10 arrangement, for transforming a signal originating from the  
multiplying arrangement to the frequency domain,  
which transforming arrangement generates, after determining an  
absolute value, a signal parameter as a function of time and  
frequency.

15

8. Device according to Claim 1, 2, 3, 4, 5 or 6, characterized in  
that a signal processing arrangement is provided with  
- a subband filtering arrangement for filtering a signal to be fed  
to an input of the signal processing arrangement,  
20 which subband filtering arrangement generates, after determining an  
absolute value, a signal parameter as a function of time and  
frequency.

9. Device according to Claim 7 or 8, characterized in that the  
25 signal processing arrangement is furthermore provided with  
- a converting arrangement for converting a signal parameter  
represented by means of a time spectrum and a frequency spectrum into  
a signal parameter represented by means of a time spectrum and a Bark  
spectrum.

30

10. Method for determining the quality of an output signal to be  
generated by a signal processing circuit with respect to a reference  
signal, which method comprises the following steps of  
- generating a first signal parameter as a function of time and  
35 frequency in response to the output signal,  
- compressing a first signal parameter and generating a second  
compressed signal parameter,  
- generating a second compressed signal parameter in response to

the reference signal,

- determining a differential signal on the basis of the compressed signal parameters, and

- generating a quality signal by integrating the differential

5 signal with respect to frequency and time,

characterized in that the method furthermore comprises the following step of

- comparing at least one of said signals with an other signal, and making a selection in dependence of the comparison result.

10

11. Method according to Claim 10, characterized in that the step of comparing comprises the step of

- comparing, per time-interval, the differential signal which has been integrated with respect to frequency with the other signal having

15 a predefined value and in case the integrated differential signal

being larger than the other signal integrating said integrated

differential signal with respect to time and in case the differential

signal which has been integrated with respect to frequency being

smaller than the other signal not integrating said integrated

20 differential signal with respect to time.

12. Method according to Claim 10, characterized in that the step of comparing comprises the steps of

- comparing a quality signal associated with a left channel of the

25 signal processing circuit with a quality signal associated with a right channel of the signal processing circuit, and

- selecting the quality signal having the largest value.

30 13. Method according to Claim 12, characterized in that in case the quality signal associated with the right channel being larger than a sum of the quality signal associated with the left channel and a

signal having a further predefined value the quality signal associated with the right channel is selected and in case the quality signal

associated with the right channel being smaller than a sum of the

35 quality signal associated with the left channel and the signal having

the further predefined value the quality signal associated with the

left channel is selected.

14. Method according to Claim 13, characterized in that the selected quality signal is multiplied with a signal having a value which depends upon at least a correlation between differential signals which have been integrated with respect to frequency and associated with the left channel and differential signals which have been integrated with respect to frequency and associated with the right channel.

15. Method according to Claim 10, 11, 12, 13 or 14, characterized in that the step of generating a second compressed signal parameter in response to the reference signal comprises the following two steps of

- generating a second signal parameter in response to the reference signal as a function of both time and frequency, and
- compressing a second signal parameter.

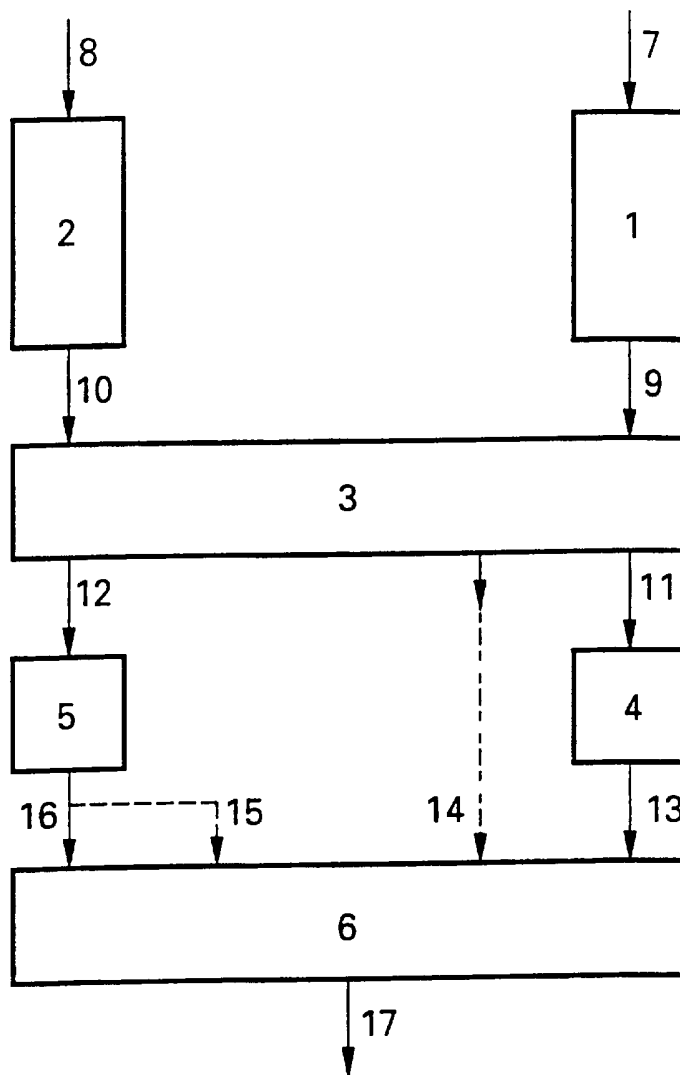

FIG. 1

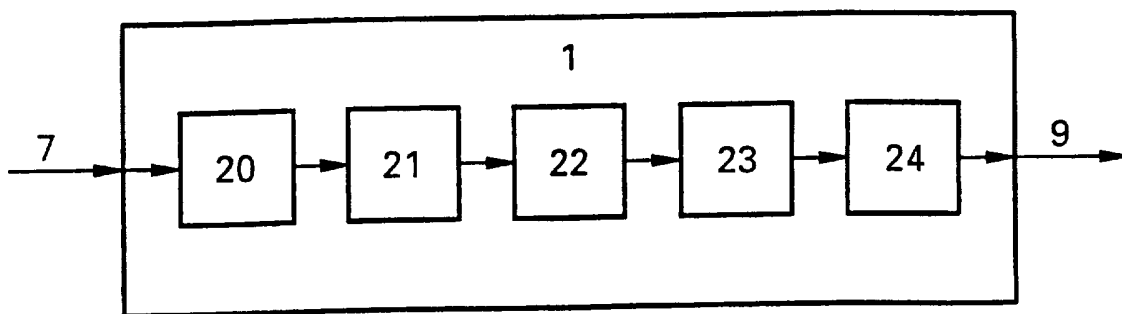

FIG. 2

2/4

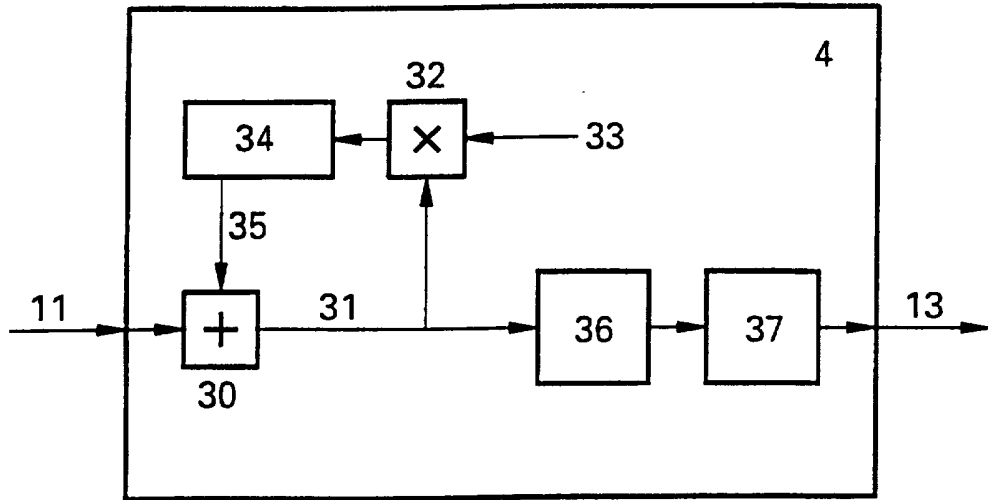

FIG. 3

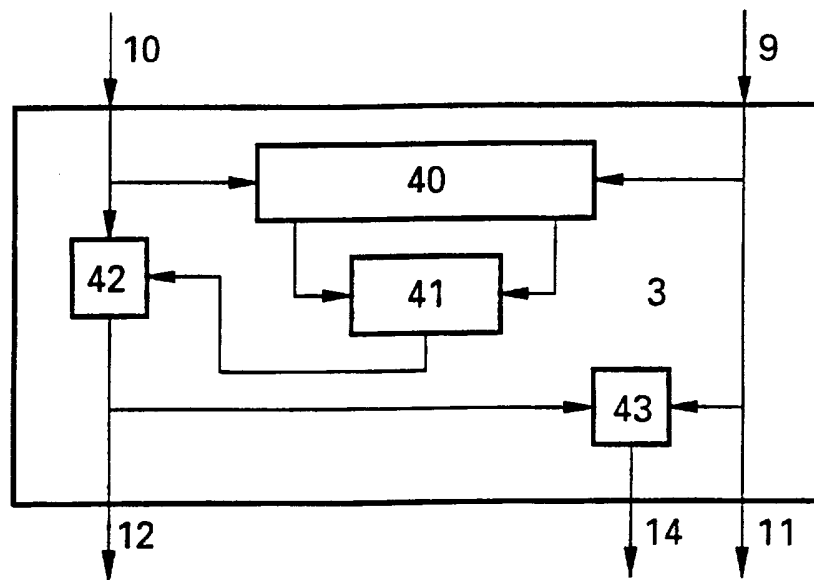

FIG. 4

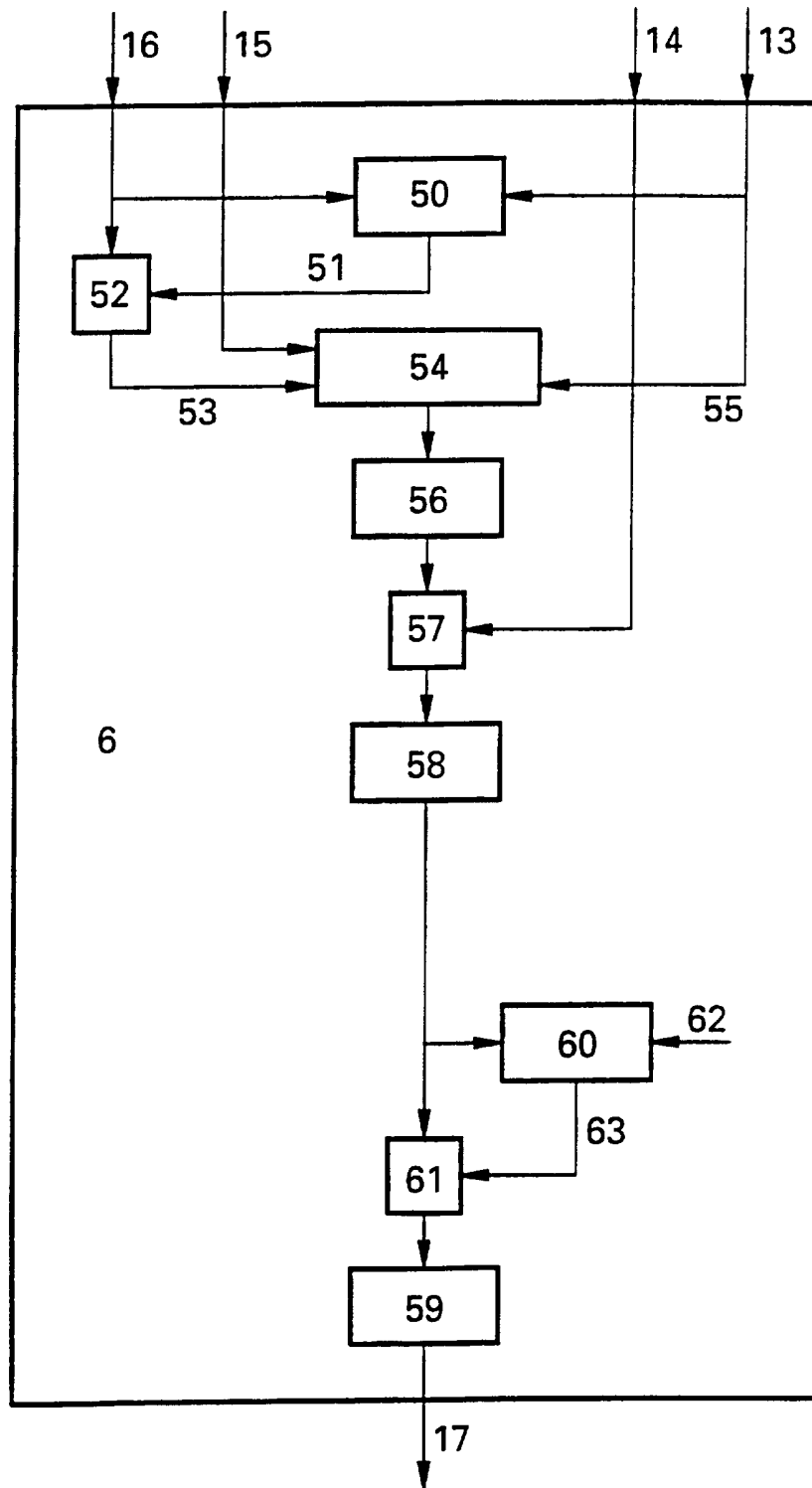

FIG. 5

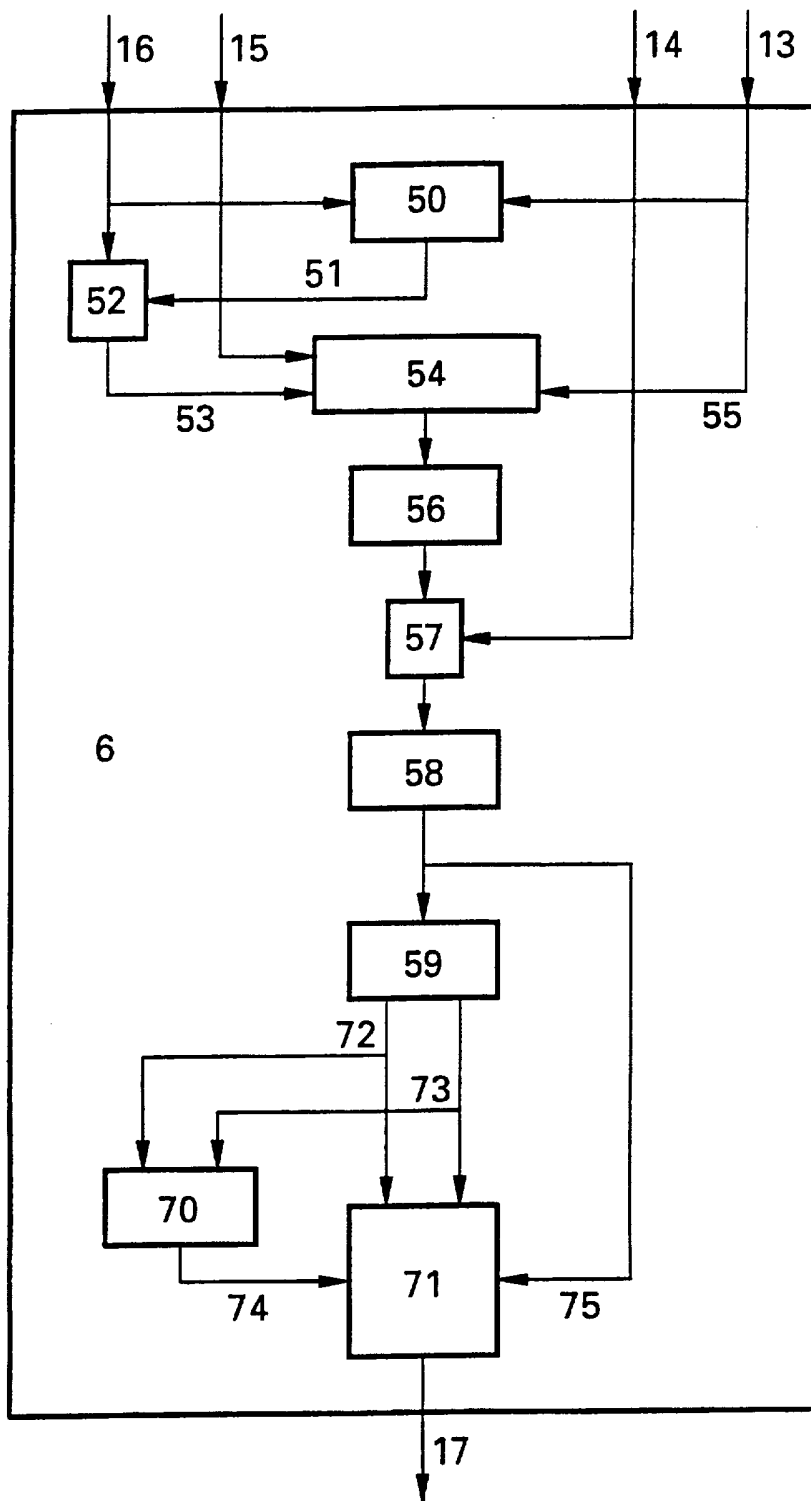

FIG. 6

# INTERNATIONAL SEARCH REPORT

International Application No  
PCT/EP 97/02712

A. CLASSIFICATION OF SUBJECT MATTER  
IPC 6 G10L5/00

According to International Patent Classification (IPC) or to both national classification and IPC

**B. FIELDS SEARCHED**

Minimum documentation searched (classification system followed by classification symbols)  
IPC 6 G10L H04L

Documentation searched other than minimum documentation to the extent that such documents are included in the fields searched

Electronic data base consulted during the international search (name of data base and, where practical, search terms used)

**C. DOCUMENTS CONSIDERED TO BE RELEVANT**

Category *	Citation of document, with indication, where appropriate, of the relevant passages	Relevant to claim No.
A	BEERENDS J G ET AL: "A PERCEPTUAL AUDIO QUALITY MEASURE BASED ON A PSYCHOACOUSTIC SOUND REPRESENTATION" JOURNAL OF THE AUDIO ENGINEERING SOCIETY, vol. 40, no. 12, 1 December 1992, pages 963-978, XP000514954 cited in the application see abstract; figures 1,7 see page 969, right-hand column, line 36 - page 969, right-hand column, line 48 see paragraph APP.F	1,9,10
A	--- EP 0 417 739 A (FUJITSU LTD) 20 March 1991 cited in the application see abstract; figure 2 --- -/--	1,10

Further documents are listed in the continuation of box C.

Patent family members are listed in annex.

\* Special categories of cited documents :

- "A" document defining the general state of the art which is not considered to be of particular relevance
- "E" earlier document but published on or after the international filing date
- "L" document which may throw doubts on priority claim(s) or which is cited to establish the publication date of another citation or other special reason (as specified)
- "O" document referring to an oral disclosure, use, exhibition or other means
- "P" document published prior to the international filing date but later than the priority date claimed

- "T" later document published after the international filing date or priority date and not in conflict with the application but cited to understand the principle or theory underlying the invention
- "X" document of particular relevance; the claimed invention cannot be considered novel or cannot be considered to involve an inventive step when the document is taken alone
- "Y" document of particular relevance; the claimed invention cannot be considered to involve an inventive step when the document is combined with one or more other such documents, such combination being obvious to a person skilled in the art.
- "&" document member of the same patent family

3

Date of the actual completion of the international search  <p style="text-align: center; font-weight: bold;">8 September 1997</p>	Date of mailing of the international search report  <p style="text-align: center; font-weight: bold;">12.09.97</p>
Name and mailing address of the ISA European Patent Office, P.B. 5818 Patentlaan 2 NL - 2280 HV Rijswijk Tel. (+ 31-70) 340-2040, Tx. 31 651 epo nl, Fax: (+ 31-70) 340-3016	Authorized officer  <p style="text-align: center; font-weight: bold;">Van Doremalen, J</p>

**INTERNATIONAL SEARCH REPORT**

International Application No  
PCT/EP 97/02712

C.(Continuation) DOCUMENTS CONSIDERED TO BE RELEVANT

Category	Citation of document, with indication, where appropriate, of the relevant passages	Relevant to claim No.
A	EP 0 673 013 A (MITSUBISHI ELECTRIC CORP) 20 September 1995 see abstract see page 2, line 1 - page 3, line 5 ---	1,9,10
A	ALOKNATH DE ET AL: "RATE-DISTORTION FUNCTION FOR SPEECH CODING BASED ON PERCEPTUAL DISTORTION MEASURE" COMMUNICATION FOR GLOBAL USERS, INCLUDING A COMMUNICATIONS THEORY MINI CONFERENCE ORLANDO, DEC. 6 - 9, 1992, vol. 1 - 2 - 03, 6 December 1992, INSTITUTE OF ELECTRICAL AND ELECTRONICS ENGINEERS, pages 452-456, XP000357828 see abstract; figure 4 see paragraph 4.1-4.2 ---	1,10
A	HANSEN J H L ET AL: "OBJECTIVE SPEECH QUALITY ASSESSMENT AND THE RPE-LTP CODING ALGORITHM IN DIFFERENT NOISE AND LANGUAGE CONDITIONS" JOURNAL OF THE ACOUSTICAL SOCIETY OF AMERICA, vol. 97, no. 1, 1 January 1995, pages 609-627, XP000491242 see figure 1 see page 611, right-hand column, line 14 - line 40 -----	1,10

# INTERNATIONAL SEARCH REPORT

information on patent family members

International Application No

PCT/EP 97/02712

Patent document cited in search report	Publication date	Patent family member(s)	Publication date
EP 0417739 A	20-03-91	JP 3098318 A CA 2024742 A,C DE 69020269 D DE 69020269 T US 5224167 A	23-04-91 12-03-91 27-07-95 25-01-96 29-06-93
EP 0673013 A	20-09-95	JP 7261797 A CA 2144268 A	13-10-95 19-09-95