



- (51) International Patent Classification:
H05K 7/14 (2006.01) *H05K 7/18* (2006.01)
- (21) International Application Number:
PCT/US2015/027592
- (22) International Filing Date:
24 April 2015 (24.04.2015)
- (25) Filing Language: English
- (26) Publication Language: English
- (71) Applicant: **HEWLETT PACKARD ENTERPRISE DEVELOPMENT LP** [US/US]; 11445 Compaq Center Drive West, Houston, TX 77070 (US).
- (72) Inventors: **SCHULZE, James Jeffery**; 11445 Compaq Center Drive West, Houston, Texas 77070 (US). **KRONTZ, Jeoff M.**; 11445 Compaq Center Drive West, Houston, Texas 77070 (US). **DUPUY, James, Jr.**; 11445 Compaq Center Drive West, Houston, Texas 77070 (US). **TOMASZEWSKI, Richard J.**; 11445 Compaq Center Drive West, Houston, Texas 77070 (US). **YATES, James Kenneth**; 11445 Compaq Center Drive West, Houston, Texas 77070 (US).

(74) Agents: **CARTER, Daniel J.** et al.; Hewlett Packard Enterprise, 3404 E. Harmony Road, Mail Stop 79, Fort Collins, CO 80528 (US).

(81) Designated States (unless otherwise indicated, for every kind of national protection available): AE, AG, AL, AM, AO, AT, AU, AZ, BA, BB, BG, BH, BN, BR, BW, BY, BZ, CA, CH, CL, CN, CO, CR, CU, CZ, DE, DK, DM, DO, DZ, EC, EE, EG, ES, FI, GB, GD, GE, GH, GM, GT, HN, HR, HU, ID, IL, IN, IR, IS, JP, KE, KG, KN, KP, KR, KZ, LA, LC, LK, LR, LS, LU, LY, MA, MD, ME, MG, MK, MN, MW, MX, MY, MZ, NA, NG, NI, NO, NZ, OM, PA, PE, PG, PH, PL, PT, QA, RO, RS, RU, RW, SA, SC, SD, SE, SG, SK, SL, SM, ST, SV, SY, TH, TJ, TM, TN, TR, TT, TZ, UA, UG, US, UZ, VC, VN, ZA, ZM, ZW.

(84) Designated States (unless otherwise indicated, for every kind of regional protection available): ARIPO (BW, GH, GM, KE, LR, LS, MW, MZ, NA, RW, SD, SL, ST, SZ, TZ, UG, ZM, ZW), Eurasian (AM, AZ, BY, KG, KZ, RU, TJ, TM), European (AL, AT, BE, BG, CH, CY, CZ, DE, DK, EE, ES, FI, FR, GB, GR, HR, HU, IE, IS, IT, LT, LU, LV, MC, MK, MT, NL, NO, PL, PT, RO, RS, SE, SI, SK, SM, TR), OAPI (BF, BJ, CF, CG, CI, CM, GA, GN, GQ, GW, KM, ML, MR, NE, SN, TD, TG).

[Continued on next page]

(54) Title: ADAPTER ASSEMBLIES

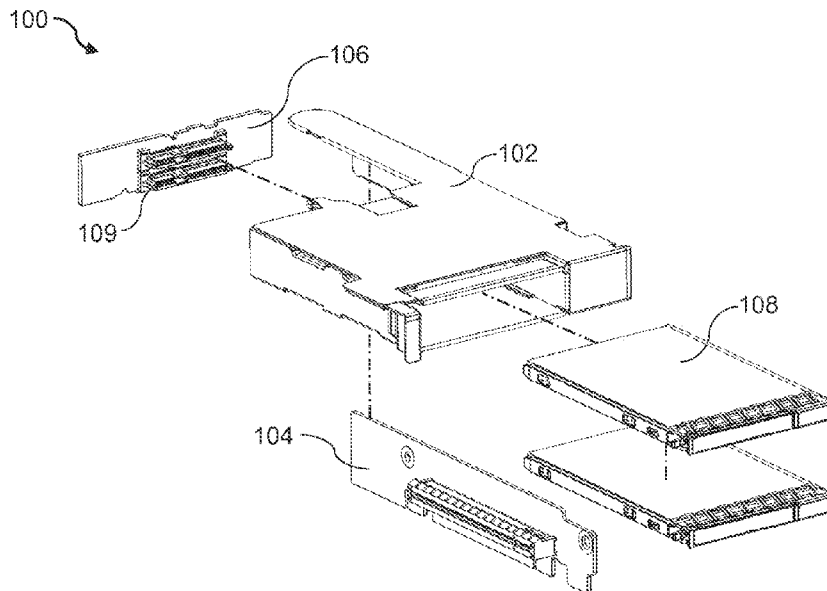

Fig. 1B

(57) Abstract: An example adapter assembly may comprise an adapter cage to removably mount to a riser board of a computer system. Further, the example adapter assembly may comprise an adapter board disposed on the adapter cage, wherein the adapter cage is to receive multiple computer components, and the adapter board is to engage with the multiple computer components.



Declarations under Rule 4.17:

- *as to the identity of the inventor (Rule 4.17(i))*
- *as to applicant's entitlement to apply for and be granted a patent (Rule 4.17(ii))*

Published:

- *with international search report (Art. 21(3))*

ADAPTER ASSEMBLIES

BACKGROUND

[0001] Computer systems, including server systems, can have main system boards. System boards can include computer system components, including expansion connectors, sometimes referred to as expansion slots. Computer expansion slots can interface and engage with various computer or expansion components that a user may want to connect to the computer system in order to enhance the performance or capabilities of the computer system. Some expansion components may engage with an expansion slot of a computer system through a riser board. Riser boards may include expansion slots to engage with expansion components. A riser board may allow an expansion component to be engaged with the computer system in a more compact configuration.

BRIEF DESCRIPTION OF THE DRAWINGS

- [0002] Fig. 1A is a perspective view of an example adapter assembly.
- [0003] Fig. 1B is a perspective exploded view of an example adapter assembly.
- [0004] Fig. 2A is a perspective view of an example adapter assembly, including cut lines 2B and 2C.
- [0005] Fig. 2B is a front cross-sectional view of an example adapter assembly, taken along cut line 2B.
- [0006] Fig. 2C is a top cross-sectional view of an example adapter assembly, taken along cut line 2C.
- [0007] Fig. 3A is a perspective view of a computer system including an example adapter assembly.
- [0008] Fig. 3B is a perspective exploded view of a computer system including an example adapter assembly.
- [0009] Fig. 4A is a front cross-sectional view of an example adapter assembly.

[0010] Fig. 4B is a perspective view of a computer system including an example adapter assembly.

DETAILED DESCRIPTION

[0011] Computer systems, including server systems, may include main system boards that engage with various computer components. The system board may engage with computer components through the use of expansion connectors or slots on the system board. The computer components may include edge connectors with multiple contacts, pads, or pins, *e.g.*, gold finger connectors, to interface with such expansion slots. Expansion slots can engage with computer components in order to enhance the performance or capabilities of the computer system. Expansion slots may use an expansion bus of the computer system to connect computer components to the main system bus of the computer system for the transfer of data. Expansion slots may include Peripheral Component Interconnect (PCI) slots, Accelerated Graphics Port (AGP) slots, Peripheral Component Interconnect Express (PCIe) slots, or other computer bus standard slots. In some situations, the computer components may engage with the expansion slots through riser boards.

[0012] Riser boards may be used to engage computer components with expansion slots of the computer system. A riser board may engage with an expansion slot using an edge connector, which may insert into the slot in a manner that may be perpendicular to the system board. A riser board may also include one or more expansion slots of its own such that one or more computer components may engage with the riser board through the expansion slots, and, further, insert in a manner that is perpendicular to the riser board. Riser boards may, therefore, allow computer components to engage with expansion slots of the system board while the expansion components are disposed above the system board in a more compact configuration than if each expansion component was insertably engaged with an expansion slot of the system board directly.

[0013] Computer systems may also engage with storage drives for the storage of data. The computer systems may engage with storage drives through the use of dedicated storage drive bays. Additionally, the computer system may engage with such storage drives through expansion slots, as described above. Such storage drives, in some situations, may be supplementary storage drives for the backing-up of data, or for increasing the storage density of a

computer system, including server systems. Further, such a storage drive may be used as a boot drive for the configuration of the computer system. In some situations, such supplementary storage drives may be an upgrade option for the computer system, and the computer system may have a dedicated area within it for the location of the storage drives of such an upgrade option. In the event that the computer system is employed without the upgrade option installed, the dedicated area within the computer system may be left empty, effectively wasting that internal volumetric space. It may be desirable in some computer systems, such as server systems, to avoid wasting internal space within the system, yet to still offer an upgrade option that will allow a user to increase the storage capacity or density of the system for a variety of reasons.

[0014] Additionally, such an upgrade option may require the disassembly or opening of the computer system to install, remove, or troubleshoot the storage drive or drives therein. In some situations, it may be desirable to employ such an upgrade option where the storage drives are hot-pluggable, instead. Here, hot-pluggable may refer to the ability of the storage drives to be inserted or removed from the computer system without the need to shut the computer system down and without risking a loss of data of the storage drives. In order to make the storage drive or drives of such an upgrade option hot-pluggable, it may be necessary to replace or redesign an entire panel or side of the computer system for variations of the system that will include the hot-pluggable upgrade option.

[0015] Further, expansion slots may be employed in a computer system to engage an upgrade option with the computer system. In some situations, expansion components other than storage drives may be available as such an upgrade option. In the event that the computer system is employed without the upgrade option installed, the expansion slot may not be used, therefore, effectively wasting the volumetric space within the computer system that is around the expansion slot.

[0016] Implementations of the present disclosure provide an adapter assembly that can mount within an existing computer system and provide additional computer or expansion components or storage drives for the system. The present disclosure may further provide an adapter assembly that can enable hot-pluggable storage drives to be implemented within an existing computer system without replacing or redesigning significant structural components of the system. Further, the provided adapter assemblies may utilize unused space above or around

empty expansion slots within the computer system to provide volumetric space for an upgrade option for a user.

[0017] Referring now to Fig. 1A, a perspective view of an example adapter assembly 100 is illustrated. The adapter assembly 100 may comprise an adapter cage 102 and an adapter board 106 disposed on or within the adapter cage 102. The adapter cage 102 may be a rigid or semi-rigid structural component that may engage with other structural components of a computer system. In some implementations, the adapter cage 102 may comprise a rectangular geometry or cross-section. In further implementations, the adapter cage 102 may comprise a different geometry or cross-section. In some implementations, the adapter cage 102 may be constructed such that the cage 102 protects computer components disposed within the cage from static or electrical interference, or from physical contact, shock, vibration, or other potentially damaging occurrences. In some implementations, the adapter cage 102 may comprise a metallic material, such as steel or aluminum. In further implementations, the adapter cage may comprise sheet metal which may be formed by stamping, folding, pressing, or other manufacturing processes. In yet further implementations, the adapter cage may comprise a polymer material, such as molded or machined plastic.

[0018] The adapter cage 102 may engage with one or more, or multiple computer components 108 and a computer system such that the computer components 108 are removably fixed within the computer system through their engagement with the adapter cage 102. In some implementations, the computer components 108 may be partially or wholly disposed within the adapter cage 102. In further implementations, the adapter cage 102 may removably receive the computer components 108 within an opening in the adapter cage. In yet further implementations, the adapter cage 102 may receive the computer components 108 in a stacked fashion, or slidably receive the computer components 108 in a stacked fashion. A stacked fashion may refer to the orientation of the computer components 108 relative to each other and, further, may mean that the computer components 108 are arranged substantially parallel to each other. Moreover, the adapter cage 102 may receive the multiple computer components 108 in a stacked fashion such that they are arranged substantially perpendicular to the adapter board 106 and a riser board of the computer system. The adapter cage 102 may, in some implementations, removably receive each of the one or more computer components 108 individually from each other. In other words, each computer component 108 may be inserted into or removed from the

adapter cage 102 separately from any other computer component 108 that may be engaged with the adapter cage 102.

[0019] Referring additionally to Fig. 1B, a perspective exploded view of an example adapter assembly 100 is illustrated. The adapter cage 102 may engage with a computer system by mechanically engaging with a structural component of the computer system, such as an exterior panel, case, rack, enclosure, or interior bay or support. Further, the adapter cage 102 may also mechanically engage with a non-structural component of the computer system, such as a system board or a riser board 104 of the computer system that may be engaged with the system board. The riser board 104 may be engaged with an expansion slot on the system board of the computer system. In some implementations, the adapter cage 102 may removably engage with an existing riser board 104 disposed within the computer system. In further implementations, the adapter cage 102 may removably fix the computer components 108 relative to the computer system, the riser board 104 therein, or any structural components of the computer system that the adapter cage 102 may be engaged with.

[0020] The example adapter assembly 100 may further comprise an adapter board 106 disposed on the adapter cage 102. The adapter board 106 may structurally support and electrically connect multiple electronic components. The adapter board 106 may, in some implementations, connect multiple electronic components with conductive pathways, which, in further implementations, may include copper. In yet further implementations, the adapter board 106 may be made, at least partially, out of a non-conductive substrate with copper pathways etched onto the substrate. In some implementations, the non-conductive substrate may include silicone. In further implementations, the adapter board 106 might comprise a single-layer printed circuit board (PCB), or a multi-layer PCB in other implementations.

[0021] The adapter board 106 may be disposed on or within the adapter cage 102, in some implementations, such that the adapter cage 102 fixes the adapter board 106 in position within the computer system. In this context, disposed on or within the adapter cage may refer to the adapter board 106 being positioned on the outside or partially or wholly within the adapter cage 102. The adapter board 106 may further be fixed by the adapter cage 102 relative to the computer system, the riser board 104 therein, or any structural components of the computer system that the adapter cage 102 may be engaged with. In some implementations, the adapter board 106 may operably engage with the one or more, or multiple computer components 108. In

some implementations, the adapter board 106 may operably engage with the computer components 108 through electrical connectors 109, which may be disposed on the adapter board 106. The adapter cage 102 may align the computer components 108 with the adapter board 106 such that they may engage with the adapter board 106 through the electrical connectors 109. Further, the computer components 108 may engage with and electrically communicate with the computer system through the adapter board 106. The adapter board 106 may facilitate electrical communication between the computer components 108 and the computer system through cabling or other connectors from the adapter board 106 to the computer system. In some implementations, the computer components 108 only electrically communicate with the computer system through the adapter board 106. The adapter board 106 may also provide power to the computer components 108. To accomplish this, the adapter board 106 may receive power from the computer system through the riser board 104. In some implementations, the adapter board 106 may receive power from the computer system from a different riser board or another portion of the computer system. The riser board 106 may then provide the received power to the computer components 108 through the electrical connectors 109.

[0022] The electrical connectors 109 may be disposed on the adapter board 106 such that they are engaged with the conductive pathways of the adapter board 106. The electrical connectors 109 may each be electrical interfaces to engage with a complementary electrical connector or edge connector. In some implementations, the electrical connectors 109 may each engage with a complementary electrical connector comprising multiple pins. In some implementations, the electrical connectors 109 may comprise sockets, or female connectors to each engage with a complementary male connector. In further implementations, the electrical connectors 109 may each be an electrical interface to removably engage with a complementary storage drive interface in a hot-pluggable fashion. In yet further implementations, the electrical connectors 109 may each be a Serial Attached Small Computer System Interface (SAS) connector. In further implementations, the electrical connectors 109 may each be 29-pin SAS connectors.

[0023] The one or more computer components 108 may be components that increase the performance or capabilities of the computer system. In some implementations, the computer components may be expansion components that may engage with an expansion bus of the computer system. In further implementations, the computer components 108 may be storage

drives for storing data of the computer system. In further implementations, the one or more, or multiple computer components 108 may be two storage drives of the same form factor. In yet further implementations, the storage drives may be hard disk drives (HDD's). In some implementations the storage drives may be solid state drives (SSD's). In further implementations, the storage drives may be optical storage drives, or comprise flash memory. In some implementations, the storage drives may be Small Form Factor (SFF) storage drives, and in further implementations, the storage drives may be 7 millimeter (mm) SFF storage drives.

[0024] Referring now to Figs. 2A and 2B, a perspective view of an example adapter assembly 200 is illustrated, as well as a front cross-sectional view of the example adapter assembly. Adapter assembly 200 may be similar to adapter assembly 100. Further, the similarly named elements of adapter assembly 200 may be similar in function and/or structure to the elements of adapter assembly 100, as they are described above. Adapter assembly 200 may include an adapter cage 202 to receive one or more computer components 208, and an adapter board 206 to engage with the computer components 208. The example adapter assembly 200 may further comprise a riser board 204 to engage with a computer system. The riser board 204 may be an existing riser board within the computer system. The riser board 204 may structurally support and electrically connect multiple electronic components. The riser board 204 may, in some implementations, connect multiple electronic components with conductive pathways, which, in further implementations, may include copper. In yet further implementations, the riser board 204 may be made, at least partially, out of a non-conductive substrate with copper pathways etched onto the substrate. In some implementations, the non-conductive substrate may include silicone. In further implementations, the riser board 102 might comprise a single-layer printed circuit board (PCB), or a multi-layer PCB in other implementations.

[0025] The riser board 204 may include an edge connector, which may include multiple pins, including signal pins, power pins, and ground pins. The multiple pins may be operably engaged with the conductive pathways of the riser board 204. The multiple pins may be to engage with complementary receptacle pins in an expansion slot 212 of the computer system such that the riser board 204 is operably engaged with such an expansion slot 212 and, thus, the computer system itself. In some implementations, the expansion slot 212 may be disposed on the system board of the computer system. The edge connector may engage with the expansion slot 212 by being inserted into the slot from a direction parallel to the slot opening and, therefore,

substantially perpendicular to the system board. The edge connector may facilitate electrical communication via one or more signal paths between the riser board 204 and the expansion slot and, thus, an expansion bus and main system bus of the computer system. In some implementations, the expansion slot may be a Peripheral Component Interconnect (PCI) slot, or a PCI Express (PCIe) expansion slot.

[0026] In some implementations, the riser board 204 may, at least partially, structurally engage the adapter assembly 200 with the computer system. This may be accomplished by the adapter cage 202 removably mounting to the riser board 204. In further implementations, the adapter assembly 200 may be further structurally engaged with the computer system through attachment to other components of the computer system, such as a portion of a panel, case, or support. In some implementations, the adapter assembly 200 may removably mount or attach to the riser board 204 through mechanical fasteners such as the example mechanical fastener 211. The riser board 200 may be an existing riser board of the computer system, and, as such, the riser board 204 may comprise an expansion slot 210 disposed on the riser board 204. Expansion slot 210 may be similar in function and/or structure to expansion slot 212, in some implementations, and the riser board 204 may electrically engage the expansion slot 210 with the expansion slot 212. The expansion slot 210 may be to receive and engage with an expansion component of the computer system and engage the expansion component with the computer system.

[0027] In some implementations, when engaged with the expansion slot 210, an expansion component of the computer system may occupy part of or the whole volumetric area of the computer system that the adapter assembly 200 would occupy if the adapter assembly 200 was engaged with the computer system through the riser board 204. Therefore, the expansion slot 212 may be unable to receive and engage with the expansion component while the adapter cage 202 is mounted to the riser board 204. In further implementations, the riser board 204 may be able to engage the adapter assembly 200 with the computer system in a first layout, while the expansion slot 210 of the riser board 204 may be able to receive and engage with an expansion component of the computer system in a second layout. In yet further implementations, the riser board 204 may not be able to be in the first layout and the second layout at the same time. In other words, the riser board 204 may not be able to structurally engage the adapter assembly 200 with the computer system if the expansion slot 210 of the riser board 204 is currently engaged with an expansion component of the computer system, and vice versa. In further

implementations, the riser board 204 may still be able to structurally engage the adapter assembly 200 with the computer system when the expansion slot 210 of the riser board 204 is currently engaged with an expansion component that has a relatively low profile. In yet further implementations, the computer components 208 do not electrically engage with the expansion slot 210.

[0028] In some implementations, the second layout may represent a regular or default version of the computer system, while the first layout may represent the computer system being equipped with an upgrade option, wherein the adapter assembly 200 is the upgrade. In further implementations, the first layout may be able to be employed without a significant change to the computer system, other than the removal or absence of the expansion component that would normally be engaged with expansion slot 210. In this context, significant change to the computer system may include changes such as using a different riser board to engage with the adapter assembly 200, modifying or changing an exterior panel or case of the computer system, or changes to the system board specifically to employ the adapter assembly 200.

[0029] Referring still to Fig. 2B, and additionally to Fig. 2C, front and top cross-sectional views of an example adapter assembly 200 are illustrated. The adapter board 206 may be attached to or disposed on the adapter cage 202 such that the adapter board 206 is located in front of the expansion slot 210 when the adapter cage 202 is mounted to the riser board 204, as illustrated in Fig. 2B. In this context, the adapter board 206 located in front of the expansion slot 210 may refer to the adapter board 206 being disposed in front of or over the portion of the slot 210 that is to engage with the edge connector of an expansion component. In some implementations, the adapter board 206 may be located along the expansion slot 210 of the riser board 204 when the adapter cage 202 is mounted to the riser board 204, as illustrated in Fig. 2C. Therefore, the adapter board 206 may, in some implementations, prevent the edge connector of an expansion component from being inserted and engaged with the expansion slot 210.

[0030] In further implementations, the adapter board 206 may comprise one or more electrical connectors 209 to engage with the computer components 208. The electrical connectors 209 may be disposed on the adapter board 206 and the adapter cage 202 may receive the computer components 208 such that, when engaged with the adapter cage 202 and the electrical connectors 209, the computer components 208 are located in front of the expansion slot 210, as illustrated in Fig. 2B, and/or along the expansion slot 210, as illustrated in Fig. 2C.

Therefore, in some implementations, when engaged with the one or more electrical connectors 209, the computer components 208 may prevent the edge connector of an expansion component from being inserted into and engaged with the expansion slot 210. In further implementations, the computer components 208, when engaged with the electrical connectors 209, may occupy at least part of the volumetric area that would otherwise be occupied by an expansion component, should the expansion slot 210 be engaged with such an expansion component.

[0031] Referring now to Fig. 3A, a perspective view of a computer system 301 comprising an example adapter assembly 300 is illustrated. Adapter assembly 300 may be similar to adapter assembly 100 or 200. Further, the similarly named elements of adapter assembly 300 may be similar in function and/or structure to the elements of adapter assembly 100 or 200, as they are described above. Adapter assembly 300 may be disposed within the computer system 301. In some implementations, the computer system 301 may be a server system to engage with a server rack or enclosure. In some implementations, the server system may be to engage with a 19-inch or a 23-inch server rack. In further implementations, the height 320 of the computer system 301 may be in increments of standard rack unit (U) heights. In yet further implementations, the computer system 301 may be a 1U height server system to engage with a server rack or enclosure, and the adapter assembly 300 is to fit within the 1U height server. In other words, the computer system may have a height 320 that is sufficiently sized to allow the computer system to be engaged with a server enclosure that can receive a 1U height server system.

[0032] The adapter assembly 300 may, in some implementations, be disposed against an opening 318 of panel 314 of the computer system 301. The panel 314 may be a structural component of the computer system 301, in some implementations. In further implementations, the panel 314 may be an exterior panel, case, or wall of the computer system. In this context, exterior panel may refer to a panel that is on the exterior of the discreet computer system 301, and not necessarily on the exterior of any supplemental enclosure, rack, or system that the computer system 301 may be engaged with or inserted into. The exterior panel may, actually, be on the interior of any such supplemental system when the computer system 301 is engaged with or inserted into the supplemental system. The panel 314 of the computer system 301 may have an opening or bay 318 against which the adapter assembly 300 is disposed. An adapter cage 302 of the adapter assembly 300, in some implementations, may receive one or more computer

components 308 such that they are aligned with and engage with an adapter board 306. The adapter cage 302 may receive the computer components 308 through the opening or bay 318 in the panel 314 of the computer system 301. The adapter cage 302 may be disposed against the exterior panel's opening or bay 318 such that each computer component 308 may be individually inserted or removed from the adapter cage 302, and, thus, the adapter assembly 300. Further, each computer component 308, in some implementations, may be hot-plugged, or inserted and removed in a hot-pluggable fashion, into the computer system 301 through the opening or bay 318.

[0033] Referring additionally to Fig. 3B, a perspective exploded view of a computer system 301 comprising an example adapter assembly 300 is illustrated. The computer system 301 may comprise a system board 316 within the computer system 301, and the example adapter assembly 300 may, in some implementations, operably engage with the computer system 301 by engaging with the system board 316. Further, the system board 316 may comprise an expansion slot 312. The expansion slot 312, in some implementations, may be similar in structure and/or function to expansion slots 210 or 212. The example adapter assembly 300 may include a riser board 304 having an edge connector. The adapter assembly 300 may, therefore, engage with the expansion slot 312 of the system board 316 by the edge connector of the riser board 304 engaging with the expansion slot 312 of the system board 316.

[0034] Referring now to Fig. 4A, a front cross-sectional view of an example adapter assembly 400 is illustrated. Adapter assembly 400 may be similar to adapter assembly 100, 200 or 300. Further, the similarly named elements of adapter assembly 400 may be similar in function and/or structure to the elements of the above-described adapter assemblies, as they are described above. The adapter assembly 400 may include a riser board 404. The riser board 404 may include a first expansion slot 410. In some implementations, the expansion slot 410 may be similar to expansion slots 210, 212, or 312, or any above-described expansion slot. Additionally, adapter assembly 400 may comprise a second expansion slot 420. Expansion slot 420 may also be similar to any of the above-described expansion slots. The first and second expansion slots 410 and 420, respectively, may be disposed on the riser board 404 such that they are operably engaged with the riser board 404. In other words, the first and second riser boards 410 and 420 may be engaged with electrically conductive pathways of the riser board 404 which, in turn, may be engaged with an edge connector of the riser board 404. In some implementations, the first

expansion slot 410 may be disposed on a first side of the riser board 404. In further implementations, the second riser board 420 may be disposed on a second side of the riser board 404. In yet further implementations, the first side and the second side of the riser board may be opposing sides of the riser board 404.

[0035] Referring still to Fig. 4A, the adapter assembly 400 may further include an adapter cage 402 to receive one or more computer components 408. The adapter cage 402 may receive the computer components 408 and align them such that they may engage with an adapter board 406 of the adapter assembly. The adapter cage 402 may mechanically engage with the riser board 404. In some implementations, the adapter cage 402 may receive the computer components 408 such that the computer components 408 are disposed on the same side of the riser board 402 as one of the expansion slots 410 or 420. In some implementations, the computer components 408 may be disposed on the same side of the riser board 404 such that the computer components 408 prevent the expansion slot on that side of the riser board 404 from engaging with an expansion component. In other words, for example, the computer components 408 may be disposed on the same side of the riser board 404 as the first expansion slot 410 such that the expansion slot 410 cannot engage with an expansion component. In further implementations, the computer components 408 may be disposed on the opposite side of the riser board 404 as the second expansion slot 420, such that neither the adapter cage 402, nor the adapter board 406 or computer components 408 impede or prevent the second expansion slot 420 from engaging with an expansion component.

[0036] Referring additionally to Fig. 4B, the adapter assembly 400 may engage with a computer system 401. The computer system 401 may receive the adapter assembly 400 such that the adapter cage 402, and any engaged computer components 408 are disposed within the computer system 401. In some implementations, the adapter cage 402 may be engaged with the riser board 404 such that the computer components 408 are disposed on the same side as the first expansion slot 410. In further implementations, the adapter cage 402 and the computer components 408 may be disposed on the opposite side as the second expansion slot 420. In such an implementation, the second expansion slot 420 may be to engage with an expansion component 422 of the computer system 401 within the computer system 401. The expansion component 422 may be able to engage with the second expansion slot 420 while the adapter cage 402 is engaged with one or more computer components 408.

CLAIMS

What is claimed is:

1. An adapter assembly, comprising:
 - an adapter cage to removably mount to a riser board of a computer system; and
 - an adapter board disposed on the adapter cage,wherein the adapter cage is to receive multiple computer components, and the adapter board is to engage with the multiple computer components.
2. The adapter assembly of claim 1, wherein the adapter cage is to receive the multiple computer components and align them with the adapter board such that they may engage with the adapter board.
3. The adapter assembly of claim 2, wherein the adapter cage is to receive the multiple computer components in a stacked fashion such that the computer components are substantially perpendicular to the riser board and the adapter board.
4. The adapter assembly of claim 2, wherein the adapter board is to engage with multiple storage drives.
5. The adapter assembly of claim 4, wherein the adapter board and the adapter cage are to allow the storage drives to be inserted and removed from the computer system in a hot-pluggable fashion.
6. The adapter assembly of claim 5, wherein the storage drives are 7 millimeter small form factor (SFF) storage drives.
7. The adapter assembly of claim 1, wherein the computer system is a 1U height server and the adapter assembly is to fit within the server.
8. An adapter assembly, comprising:
 - a riser board to engage with a computer system;
 - an adapter cage to removably mount to the riser board; and

an adapter board disposed on the adapter cage,
wherein the adapter board is to engage with multiple computer components.

9. The adapter assembly of claim 8, wherein the adapter cage is to mount to the riser board on a same side as an expansion slot disposed on the riser board.

10. The adapter assembly of claim 9, wherein the adapter cage is to receive the computer components such that, while engaged with the adapter board, the computer components are disposed in front of the expansion slot.

11. The adapter assembly of claim 10, wherein the adapter cage is to receive two storage drives in a stacked fashion, such that the storage drives are arranged substantially perpendicular to the adapter board and the riser board.

12. A computer system, comprising:

a system board disposed within the computer system, wherein the system board includes an expansion slot;

a riser board to engage with the expansion slot of the system board;

an adapter cage to removably mount to the riser board; and

an adapter board disposed on the adapter cage,

wherein the adapter cage is to receive multiple storage drives, and the adapter board is to engage with the multiple storage drives.

13. The computer system of claim 12, wherein the riser board includes a first expansion slot and a second expansion slot disposed on opposite sides of the riser board,

wherein the storage drives are located in front of the first expansion slot on the riser board, and the second expansion slot is to engage with an expansion component of the computer system.

14. The computer system of claim 13, wherein the storage drives only electrically communicate with the computer system through the adapter board.

15. The computer system of claim 14, wherein the computer system is a 1U height server.

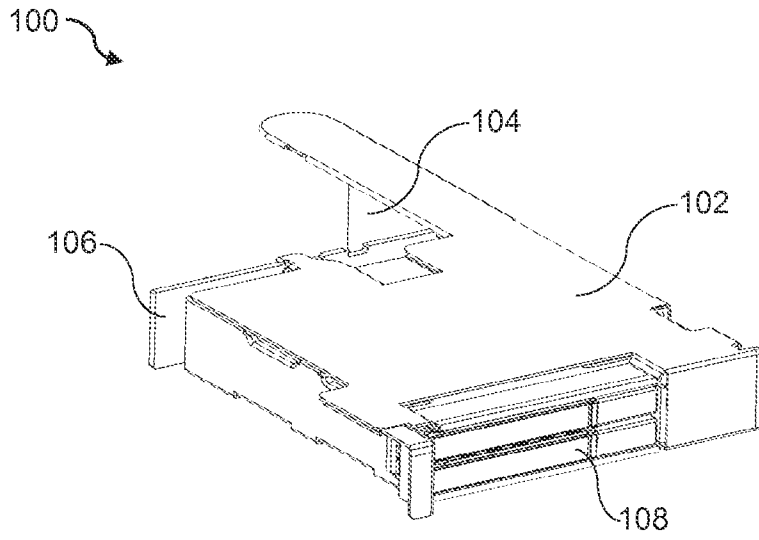

Fig. 1A

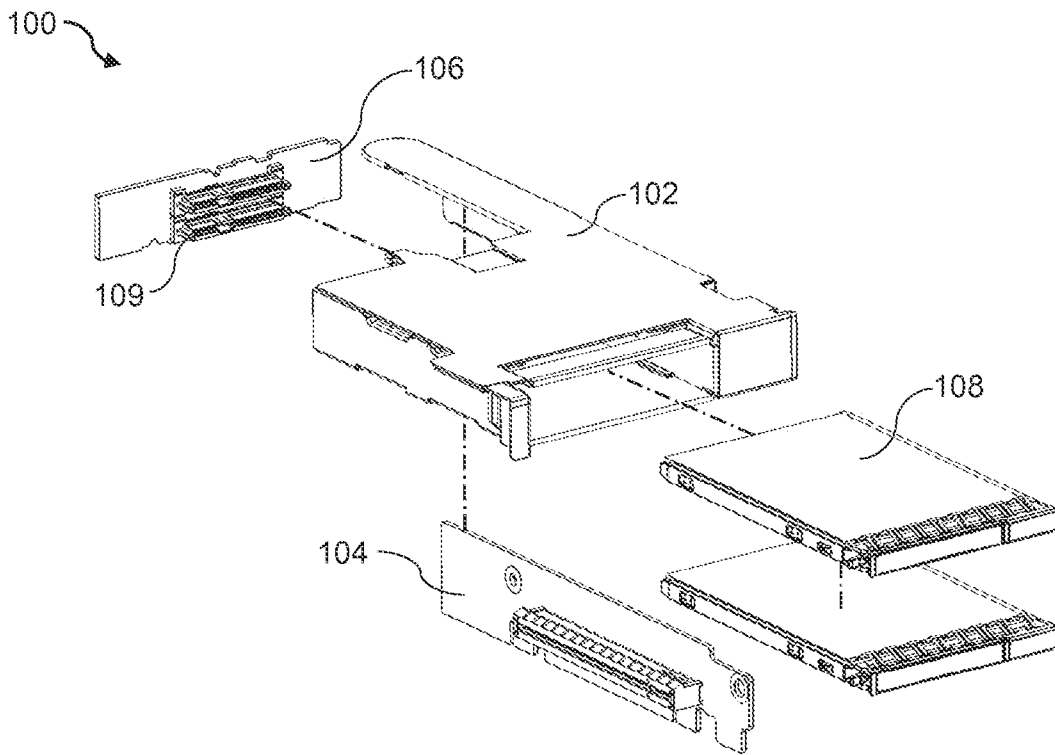

Fig. 1B

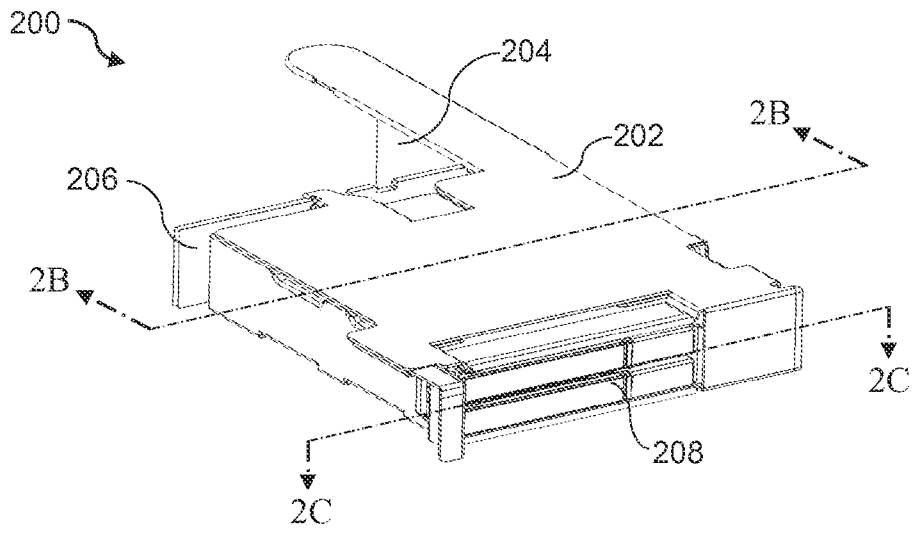

Fig. 2A

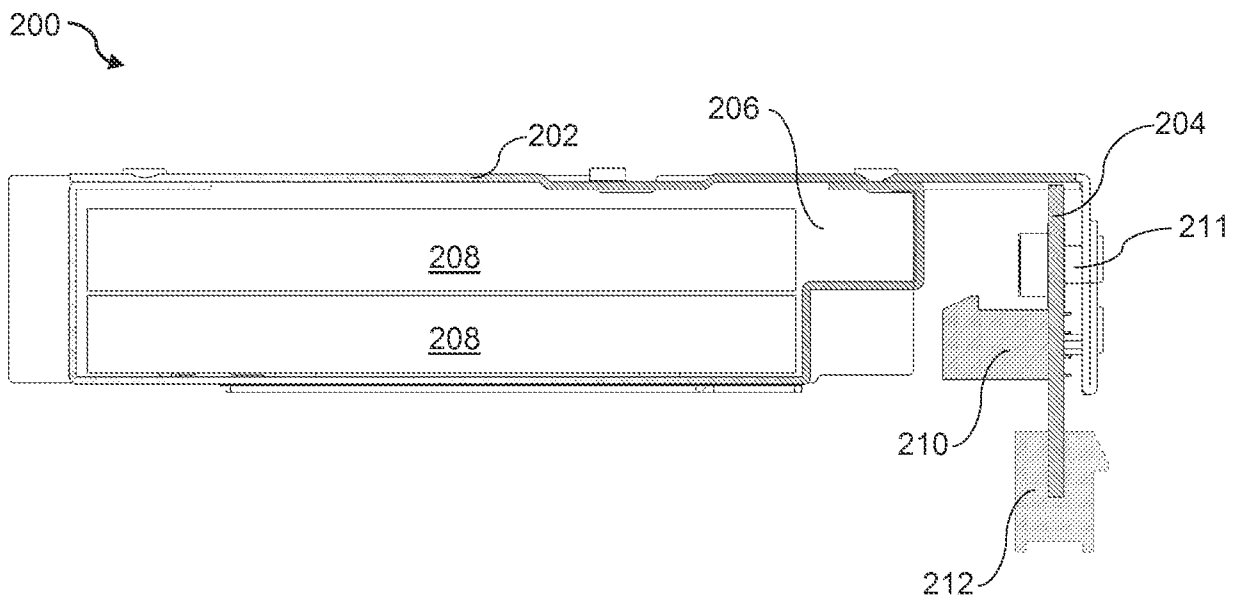

Fig. 2B

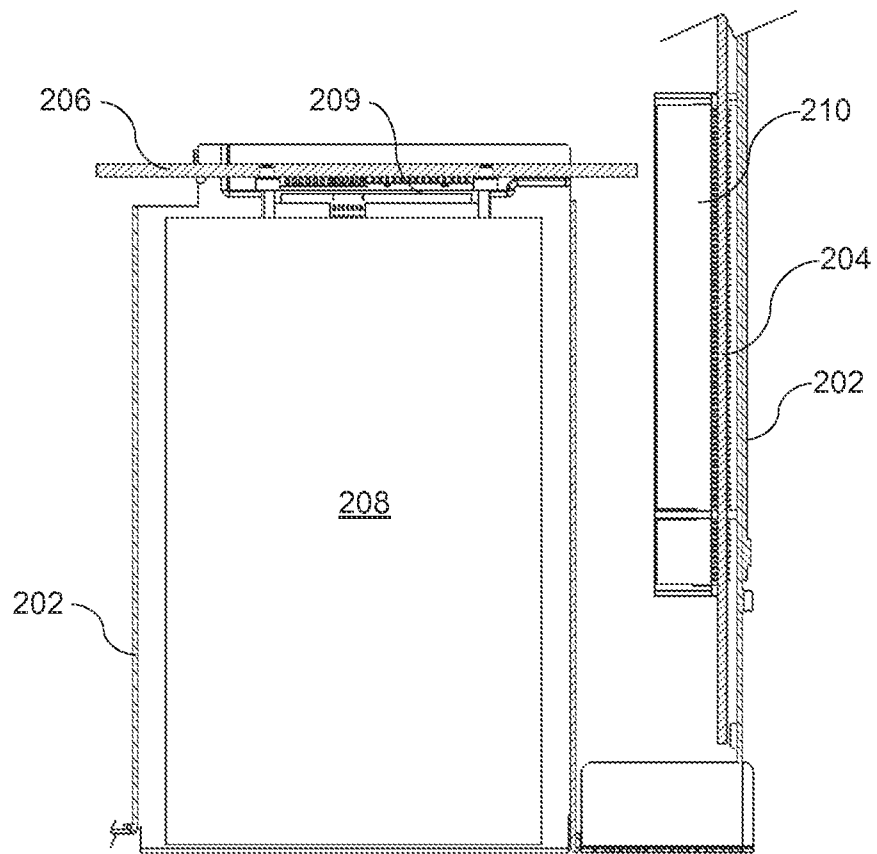

Fig. 2C

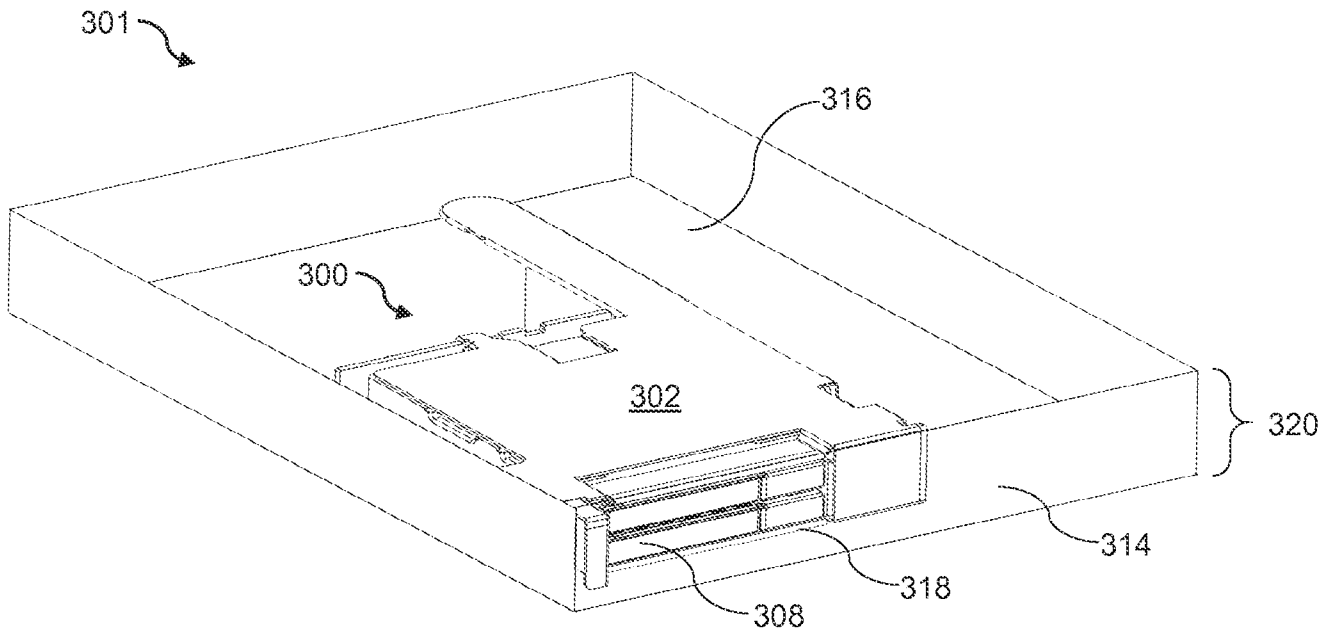

Fig. 3A

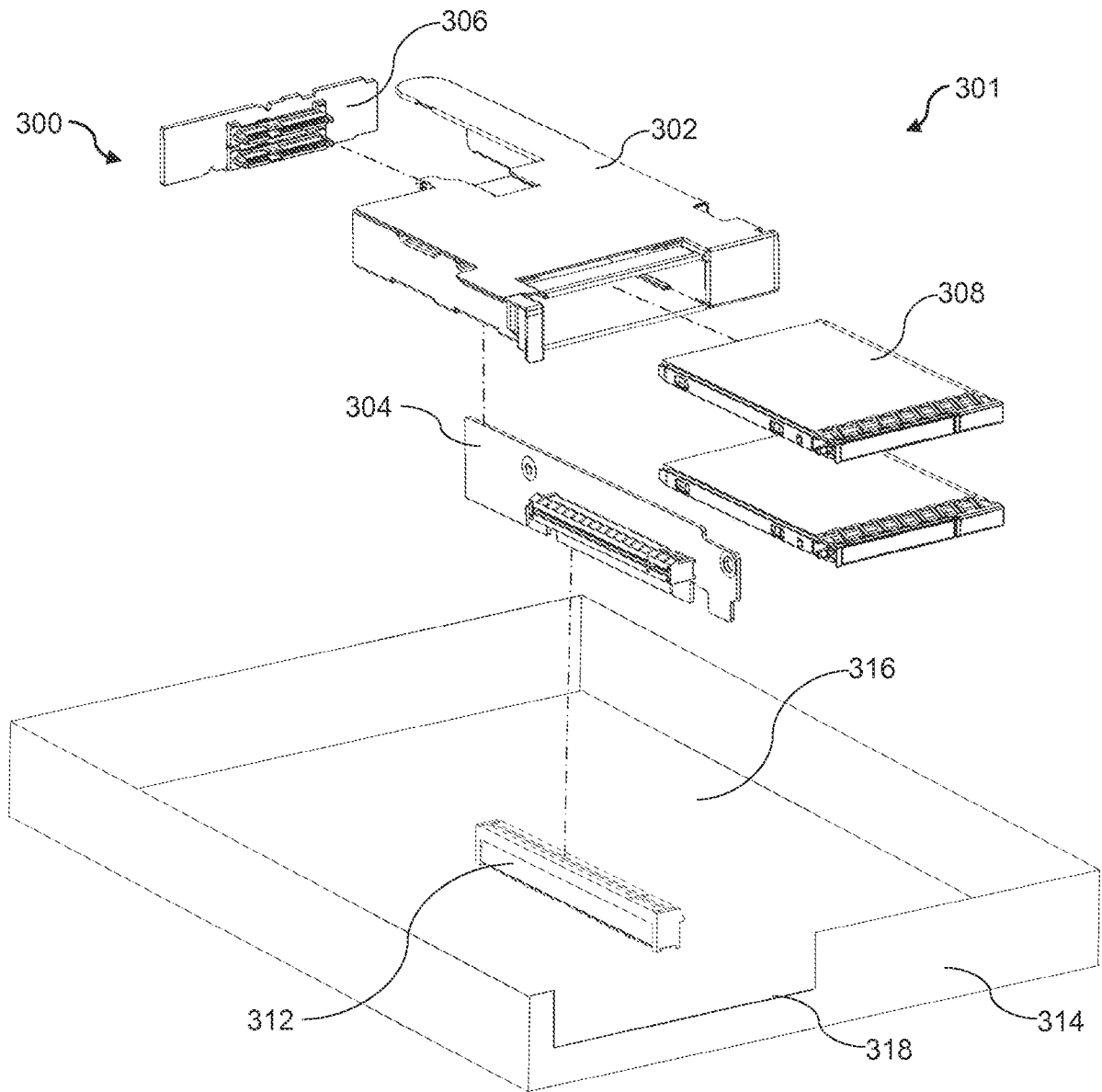

Fig. 3B

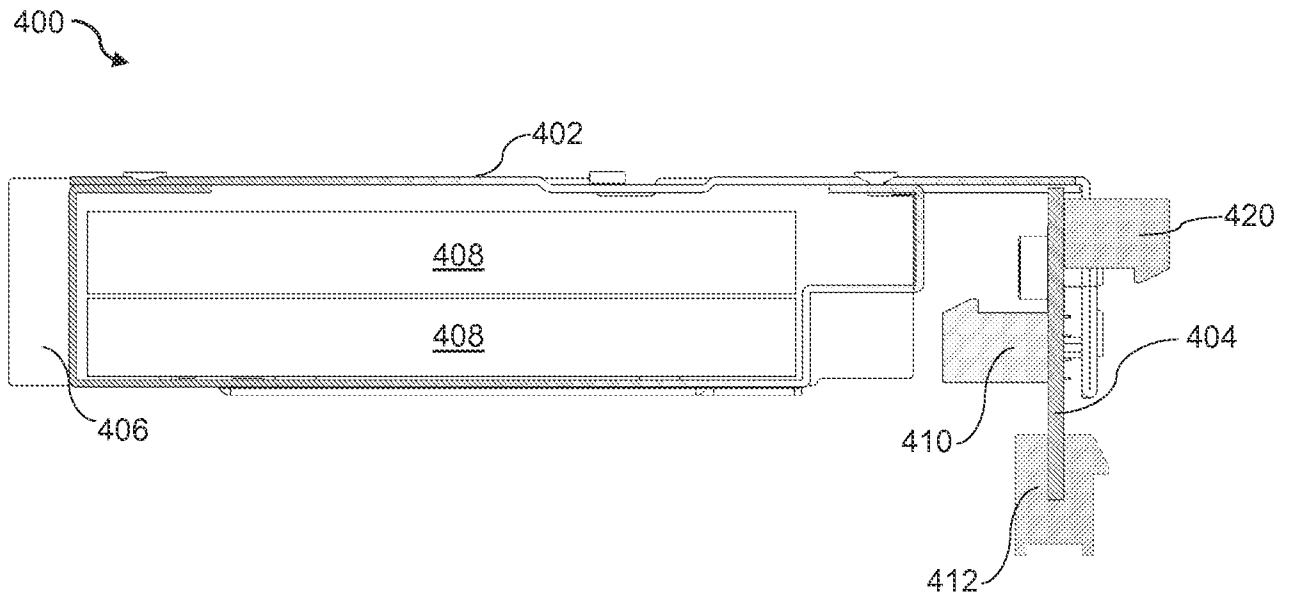

Fig. 4A

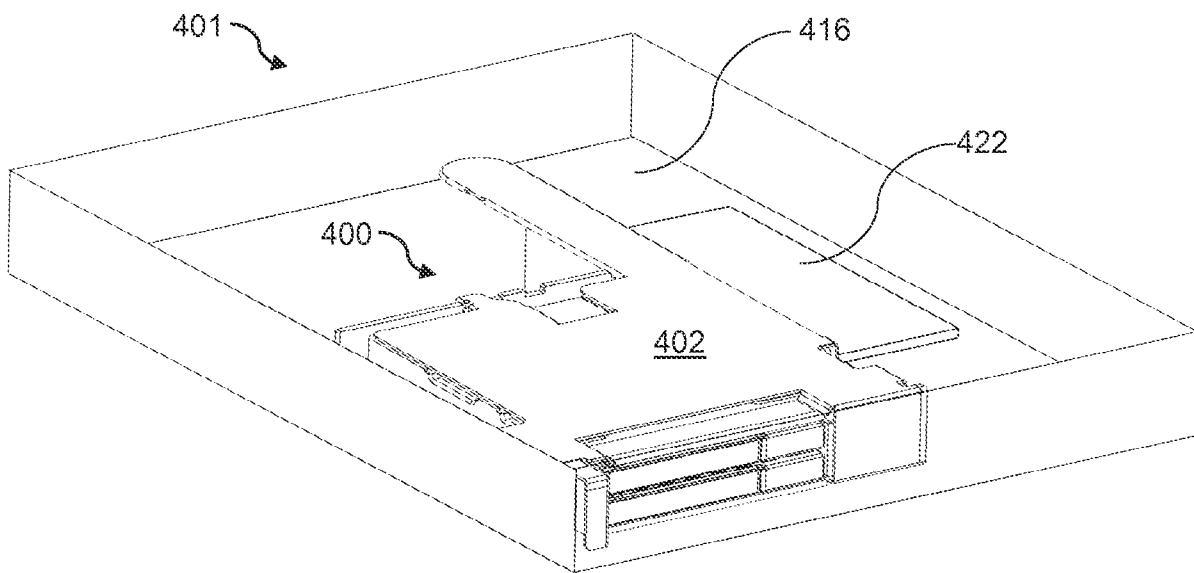

Fig. 4B

A. CLASSIFICATION OF SUBJECT MATTER**H05K 7/14(2006.01)i, H05K 7/18(2006.01)i**

According to International Patent Classification (IPC) or to both national classification and IPC

B. FIELDS SEARCHED

Minimum documentation searched (classification system followed by classification symbols)

H05K 7/14; H01R 12/51; H01R 13/64; H05K 1/14; H05K 7/00; H01R 13/62; H05K 5/00; G06F 1/16; H05K 7/18

Documentation searched other than minimum documentation to the extent that such documents are included in the fields searched

Korean utility models and applications for utility models

Japanese utility models and applications for utility models

Electronic data base consulted during the international search (name of data base and, where practicable, search terms used)

eKOMPASS(KIPO internal) & keywords: adapter assembly, adapter cage, adapter board, riser board, computer component, storage device, stack

C. DOCUMENTS CONSIDERED TO BE RELEVANT

Category*	Citation of document, with indication, where appropriate, of the relevant passages	Relevant to claim No.
Y	US 2012-0021624 A1 (GEORGE TUMA et al.) 26 January 2012 See paragraphs [0015]-[0023], claims 1-3, 14, and figures 4-7.	1-15
Y	US 5726922 A (J. SCOTT WOMBLE et al.) 10 March 1998 See column 3, lines 4-17, column 5, line 66 - column 6, line 13, claim 1, and figures 1-2.	1-15
A	US 6046912 A (MICHAEL V. LEMAN) 04 April 2000 See abstract, claims 1, 9-10, and figures 3-5.	1-15
A	US 2010-0254100 A1 (DAEHWAN KIM et al.) 07 October 2010 See claim 1, and figures 6-9.	1-15
A	US 6118668 A (ERICA SCHOLDER et al.) 12 September 2000 See claims 1-5, and figures 7-10.	1-15

 Further documents are listed in the continuation of Box C. See patent family annex.

* Special categories of cited documents:

"A" document defining the general state of the art which is not considered to be of particular relevance

"E" earlier application or patent but published on or after the international filing date

"L" document which may throw doubts on priority claim(s) or which is cited to establish the publication date of another citation or other special reason (as specified)

"O" document referring to an oral disclosure, use, exhibition or other means

"P" document published prior to the international filing date but later than the priority date claimed

"T" later document published after the international filing date or priority date and not in conflict with the application but cited to understand the principle or theory underlying the invention

"X" document of particular relevance; the claimed invention cannot be considered novel or cannot be considered to involve an inventive step when the document is taken alone

"Y" document of particular relevance; the claimed invention cannot be considered to involve an inventive step when the document is combined with one or more other such documents, such combination being obvious to a person skilled in the art

"&" document member of the same patent family

Date of the actual completion of the international search

22 January 2016 (22.01.2016)

Date of mailing of the international search report

22 January 2016 (22.01.2016)

Name and mailing address of the ISA/KR

International Application Division

Korean Intellectual Property Office

189 Cheongsa-ro, Seo-gu, Daejeon, 35208, Republic of Korea

Facsimile No. +82-42-472-7140

Authorized officer

CHOI, Sang Won

Telephone No. +82-42-481-8291



INTERNATIONAL SEARCH REPORT

Information on patent family members

International application No.

PCT/US2015/027592

Patent document cited in search report	Publication date	Patent family member(s)	Publication date
US 2012-0021624 A1	26/01/2012	US 8585442 B2 WO 2010-123502 A1	19/11/2013 28/10/2010
US 5726922 A	10/03/1998	None	
US 6046912 A	04/04/2000	None	
US 2010-0254100 A1	07/10/2010	US 2010-0254096 A1 US 8174835 B2 US 8199511 B2 WO 2010-114839 A1	07/10/2010 08/05/2012 12/06/2012 07/10/2010
US 6118668 A	12/09/2000	US 5831821 A	03/11/1998