



- (51) **International Patent Classification:**
H01M 8/18 (2006.01) *H01M 8/02* (2006.01)
H01M 8/04 (2006.01)
- (21) **International Application Number:** PCT/US2012/031174
- (22) **International Filing Date:** 29 March 2012 (29.03.2012)
- (25) **Filing Language:** English
- (26) **Publication Language:** English
- (30) **Priority Data:**
61/468,733 29 March 2011 (29.03.2011) US
13/432,243 28 March 2012 (28.03.2012) US
- (71) **Applicant** (for all designated States except US): **ENERVAULT CORPORATION** [US/US]; 1244 Reamwood Avenue, Sunnyvale, CA 94089 (US).
- (72) **Inventors; and**
- (75) **Inventors/Applicants** (for US only): **CHANG, On, Kok** [US/US]; C/o Enervault Corporation, 1244 Reamwood Avenue, Sunnyvale, CA 94089 (US). **SOPCHAK, David, Andrew** [US/US]; C/o Enervault Corporation, 1244 Reamwood Avenue, Sunnyvale, CA 94089 (US). **PHAM, Ai, Quoc** [US/US]; C/o Enervault Corporation, 1244 Reamwood Avenue, Sunnyvale, CA 94089 (US). **KINOSHITA, Kimio** [US/US]; C/o Enervault Corporation, 1244 Reamwood Avenue, Sunnyvale, CA 94089 (US).
- (74) **Agents:** **HANSEN, Robert** et al.; The Marbury Law Group, PLLC, 11800 Sunrise Valley Drive, 15th Floor, Reston, VA 20191 (US).
- (81) **Designated States** (unless otherwise indicated, for every kind of national protection available): AE, AG, AL, AM, AO, AT, AU, AZ, BA, BB, BG, BH, BR, BW, BY, BZ, CA, CH, CL, CN, CO, CR, CU, CZ, DE, DK, DM, DO, DZ, EC, EE, EG, ES, FI, GB, GD, GE, GH, GM, GT, HN, HR, HU, ID, IL, IN, IS, JP, KE, KG, KM, KN, KP, KR, KZ, LA, LC, LK, LR, LS, LT, LU, LY, MA, MD, ME, MG, MK, MN, MW, MX, MY, MZ, NA, NG, NI, NO, NZ, OM, PE, PG, PH, PL, PT, QA, RO, RS, RU, RW, SC, SD, SE, SG, SK, SL, SM, ST, SV, SY, TH, TJ, TM, TN, TR, TT, TZ, UA, UG, US, UZ, VC, VN, ZA, ZM, ZW.
- (84) **Designated States** (unless otherwise indicated, for every kind of regional protection available): ARIPO (BW, GH, GM, KE, LR, LS, MW, MZ, NA, RW, SD, SL, SZ, TZ, UG, ZM, ZW), Eurasian (AM, AZ, BY, KG, KZ, MD, RU, TJ, TM), European (AL, AT, BE, BG, CH, CY, CZ, DE, DK, EE, ES, FI, FR, GB, GR, HR, HU, IE, IS, IT, LT, LU, LV, MC, MK, MT, NL, NO, PL, PT, RO, RS, SE, SI, SK, SM, TR), OAPI (BF, BJ, CF, CG, CI, CM, GA, GN, GQ, GW, ML, MR, NE, SN, TD, TG).
- Published:**
— without international search report and to be republished upon receipt of that report (Rule 48.2(g))



(54) **Title:** MONITORING ELECTROLYTE CONCENTRATIONS IN REDOX FLOW BATTERY SYSTEMS

(57) **Abstract:** Methods, systems and structures for monitoring, managing electrolyte concentrations in redox flow batteries are provided by introducing a first quantity of a liquid electrolyte into a first chamber of a test cell and introducing a second quantity of the liquid electrolyte into a second chamber of the test cell. The method further provides for measuring a voltage of the test cell, measuring an elapsed time from the test cell reaching a first voltage until the test cell reaches a second voltage; and determining a degree of imbalance of the liquid electrolyte based on the elapsed time.

TITLE

MONITORING ELECTROLYTE CONCENTRATIONS IN REDOX FLOW BATTERY SYSTEMS

RELATED APPLICATIONS

[0001] This application claims the benefit of priority to U.S. Provisional Patent Application No. 61/468,733, filed March 29, 2011, and to U.S. Application No. 13/432,243, filed March 28, 2012. The entire contents of both these applications are incorporated herein by reference.

STATEMENT REGARDING FEDERALLY SPONSORED RESEARCH

[0002] Inventions included in this patent application were made with Government support under DE-OE0000225 "Recovery Act - Flow Battery Solution for Smart Grid Renewable Energy Applications" awarded by the US Department of Energy (DOE). The Government has certain rights in these inventions.

FIELD OF THE INVENTION

[0003] This invention generally relates to reduction-oxidation (redox) flow batteries and more particularly to monitoring and characterizing reactant concentrations in liquid flow battery electrolytes.

BACKGROUND

[0004] Flow batteries are electrochemical energy storage systems in which electrochemical reactants are dissolved in liquid electrolytes (sometimes referred to generically as "reactants"), which are pumped through reaction cells where electrical energy is either converted to or extracted from chemical potential energy in the reactants by way of reduction and oxidation reactions. In applications where megawatts of electrical energy must be stored and discharged, a redox flow battery system may be expanded to the required energy storage capacity by increasing tank sizes and expanded to produce the required output power by increasing the number or size of electrochemical cells or cell blocks. A variety of flow battery chemistries and arrangements are known in the art.

[0005] In some redox flow battery systems based on the Fe/Cr redox couple, the catholyte (in the positive half-cell) contains FeCl_3 , FeCl_2 and HCl . The anolyte (in the negative half-cell) contains CrCl_3 , CrCl_2 and HCl . Such a system is known as an "unmixed reactant" system. In a "mixed reactant" system, the anolyte also contains FeCl_2 and the catholyte also

contains CrCl_3 . In an initial state of either case, the catholyte and anolyte typically have equimolar reactant concentrations.

[0006] After a number of charge/discharge cycles, the catholyte and anolyte may become imbalanced because of side reactions during a charge and/or discharge operations. For example, in the case of an Fe/Cr redox flow battery, a hydrogen generation side-reaction occurs at the anode during the charge cycle. Such side reactions cause an imbalance in electrolyte concentrations by converting more reactant in one half-cell to a higher SOC state than occurs in the second electrolyte. In this unbalanced state, for example, the concentration of Fe^{3+} may be higher than that of Cr^{2+} . The imbalance decreases capacity of the battery and is undesirable. The proportion of hydrogen gas generated, and thus the degree of reactant imbalance, also increases as the state-of-charge (SOC) of the flow battery increases.

[0007] The imbalanced state may be corrected by processing the catholyte in a rebalancing cell. One example is an Iron/Hydrogen fuel cell as described in US Patent 4,159,366, which describes an electrolytic rebalance cell configured to oxidize waste hydrogen at a rebalance cell anode and reduce excess Fe^{3+} ions to Fe^{2+} ions at a rebalance cell cathode. H_2 may be recycled from the Cr species electrolyte and directed into the rebalance cell along with a portion of the Fe electrolyte. A catalyst may be used to promote the reaction with or without application of an applied voltage. Another example of a similar cell is provided in "Advancements in the Direct Hydrogen Redox Fuel Cell" by Khalid Fatih, David P. Wilkinson, Franz Moraw, Alan Ilicic and Francois Girard, published electronically by the Electrochemical Society November 26, 2007.

[0008] Monitoring or measuring the state of charge and the imbalance of electrolytes presents additional challenges. Such concentrations may be measured spectroscopically, as described for example in US Patent 7,855,005 to Sahu, or by any number of other methods.

SUMMARY

[0009] In one embodiment method, a degree of electrolyte imbalance in a reduction-oxidation (redox) flow battery system is determined by introducing a first liquid electrolyte into a first chamber of a test cell; introducing a second liquid electrolyte into a second chamber of the test cell; measuring a voltage of the test cell; measuring an elapsed time from the test cell reaching a first voltage until voltage test end-point is reached; and determining a concentration of at least one reactant in the first and second liquid electrolytes based on the elapsed time.

[0010] In another embodiment, an electronic controller has a processor and has a non-transitory computer-readable medium coupled to the processor and containing processor-executable instructions to perform operations for introducing a first liquid electrolyte into a first chamber of a test cell, introducing a second liquid electrolyte into a second chamber of the test cell, measuring a voltage of the test cell, measuring an elapsed time from the test cell reaching a first voltage until voltage test end-point is reached, and determining a concentration of at least one reactant in the first and second liquid electrolytes based on the elapsed time.

[0011] In an additional embodiment, a reduction-oxidation (redox) flow battery system has a redox flow battery, a test cell fluidically coupled to the flow battery, and the electronic controller for monitoring and controlling the test cell.

BRIEF DESCRIPTION OF DRAWINGS

[0012] The accompanying drawings, which are incorporated herein and constitute part of this specification, illustrate exemplary embodiments of the invention, and together with the general description given above and the detailed description given below, serve to explain the features of the invention.

[0013] FIG. 1 is a schematic illustration of a redox flow battery system including an electrolyte monitoring system according to one embodiment.

[0014] FIG. 2 is a cross-sectional view of one embodiment of an electrolyte monitoring test cell according to one embodiment.

[0015] FIG. 3 is an exploded view of one embodiment of an electrolyte monitoring test cell.

[0016] FIG. 4 is an exploded view of another embodiment of an electrolyte monitoring test cell.

[0017] FIG. 5 is a plan view of a chamber layer of the electrolyte monitoring test cell embodiment of FIG. 4.

[0018] FIG. 6A is a schematic illustration of an embodiment of a through-flow fluid delivery system for an electrolyte monitoring system.

[0019] FIG. 6B is a schematic illustration of an embodiment of a reciprocating-flow fluid delivery system for an electrolyte monitoring system.

[0020] FIG. 7A is a graph of electrolyte potential vs. concentration difference for an Fe/Cr flow battery system, with points illustrating a balanced electrolyte solution.

[0021] FIG. 7B is a graph of electrolyte potential vs. concentration difference for an Fe/Cr flow battery system, with points illustrating a positively unbalanced electrolyte solution.

[0022] FIG. 7C is a graph of electrolyte potential vs. concentration difference for an Fe/Cr flow battery system, with points illustrating charging of an unbalanced electrolyte solution.

[0023] FIG. 7D is a graph of test cell OCV vs. change in concentration difference for an Fe/Cr flow battery system, with points illustrating charging of an unbalanced electrolyte solution.

[0024] FIG. 7E is a graph of test cell OCV vs. time during charging of an unbalanced electrolyte in a test cell.

[0025] FIG. 7F is a graph of test cell OCV vs. change in concentration difference illustrating charging of a balanced electrolyte in a test cell.

[0026] FIG. 7G is a graph of electrolyte potential vs. concentration difference for an Fe/Cr flow battery system, with points illustrating a negatively unbalanced electrolyte solution.

[0027] Fig. 8 is a graph of cell voltage vs. time illustrating charging of several samples of known imbalance.

[0028] FIG. 9A is a schematic illustration of one embodiment of a reference electrode.

[0029] FIG. 9B is a schematic illustration of another embodiment of a reference electrode.

[0030] FIG. 9C is a schematic illustration of one embodiment of a reference electrode coupled to a junction in an electrolyte conduit.

[0031] FIG. 10A is a graph illustrating a graph of electrolyte potential vs. concentration difference for an Fe/Cr flow battery system, with points illustrating a process for measuring a reactant concentration using a reference electrode.

[0032] FIG. 10B is a graph illustrating potential versus change in concentration difference for the process of FIG. 10A.

[0033] FIG. 10C is a graph illustrating a graph of electrolyte potential vs. concentration difference for an Fe/Cr flow battery system, with points illustrating a process for measuring a reactant concentration using a reference electrode.

[0034] FIG. 10D is a graph illustrating potential versus change in concentration difference for the process of FIG. 10C.

[0035] FIG. 11A is a graph illustrating a section of an electrolyte potential vs. concentration difference curve for an Fe/Cr flow battery system, with points illustrating a process for measuring a reactant concentration without a reference electrode.

[0036] FIG. 11B is a graph illustrating a section of an electrolyte potential vs. concentration difference curve for an Fe/Cr flow battery system, with points illustrating a process for measuring a reactant concentration without a reference electrode..

[0037] FIG. 11C is a graph illustrating change in test cell OCV versus change in reactant concentration for the process of FIG. 11A.

[0038] FIG. 11D is a graph illustrating change in test cell OCV versus change in reactant concentration for the process of FIG. 11B.

[0039] FIG. 12A is a process flow table illustrating a control process for measuring a degree of imbalance in a pair of flow battery electrolytes.

[0040] FIG. 12B is a schematic illustration of an embodiment of a fluid delivery system that may be used with the process of FIG. 12A

[0041] FIG. 13A is a process flow table illustrating a control process for measuring a concentration of a charged electrolyte reactant in a flow battery electrolyte.

[0042] FIG. 13B is a schematic illustration of an embodiment of a fluid delivery system that may be used with the process of FIG. 13A

[0043] FIG. 14A is a process flow table illustrating a control process for measuring both a concentration of a charged electrolyte reactant in at least one electrolyte and a degree of imbalance in a pair of flow battery electrolytes.

[0044] FIG. 14B is a schematic illustration of an embodiment of a fluid delivery system that may be used with the process of FIG. 14A

[0045] FIG. 15 is a graph of time vs. imbalance for Fe/Cr flow battery electrolytes.

[0046] FIG.16 is a linearized graph of time vs. imbalance for Fe/Cr flow battery electrolytes.

[0047] FIG.17 is a graph of OCV vs. time illustrating several empirically-determined curves for samples of known imbalance.

[0048] FIG. 18 is a schematic diagram of an electronic controller for monitoring and controlling a test cell according to one embodiment.

[0048.1] FIG. 19 is a flow diagram of a method of determining a degree of electrolyte imbalance in a reduction-oxidation (redox) flow battery system according to one embodiment method.

DETAILED DESCRIPTION

[0049] INTRODUCTION AND DEFINITIONS

[0050] As used herein, the phrase “state of charge” and its abbreviation “SOC” refer to the ratio of stored electrical charges (measured in ampere-hour) to charge storage capacity of a complete redox flow battery system. In particular, the terms “state of charge” and “SOC” may refer to an instantaneous ratio of usable charge stored in the flow battery to the full ideal charge storage capacity of the flow battery system. In some embodiments, “usable” stored charge may refer to stored charge that may be delivered at or above a threshold voltage (e.g. about 0.7 V in some embodiments of an Fe/Cr flow battery system). In some embodiments, the ideal charge storage capacity may be calculated excluding the effects of unbalanced electrolytes.

[0051] As used herein the phrase “state of oxidation” and its abbreviation “SOO” refer to the chemical species composition of at least one liquid electrolyte. In particular, state of oxidation and SOC refer to the proportion of reactants in the electrolyte that have been converted (e.g. oxidized or reduced) to a “charged” state from a “discharged” state. For example, in a redox flow battery based on an iron/chromium (Fe/Cr) redox couple, the state of oxidation of the catholyte (positive electrolyte) may be defined as the percent of total Fe which has been oxidized from the ferrous iron (Fe^{2+}) form to the ferric iron (Fe^{3+}) form and the state of oxidation of the anolyte (negative electrolyte) may be defined as the negative percent of total Cr which has been reduced from the Cr^{3+} form to the Cr^{2+} form. Although many of the embodiments herein are described with reference to an Fe/Cr flow battery chemistry, it should be appreciated with the benefit of the present disclosure that some embodiments are applicable to flow battery systems (and some hybrid flow battery systems) using other reactants.

[0052] In some embodiments, the state of oxidation of the two electrolytes may be changed or measured independent of one another. Thus, the terms “state of oxidation” and “SOO” may refer to the chemical composition of only one electrolyte, or of both electrolytes in an all-

liquid redox flow battery system. The state of oxidation of one or both electrolytes may also be changed by processes other than desired charging or discharging processes. For example, undesired side reactions may cause oxidation or reduction of active species in one electrolyte without producing a corresponding reaction in the second electrolyte. Such side reactions may cause the respective SOCs of the positive and negative electrolytes to become imbalanced such that one electrolyte has a higher effective SOC than the other.

[0053] For an Fe/Cr redox flow battery, the SOO of the positive electrolyte may be defined as the ratio of the concentration of Fe^{3+} in the electrolyte to the total concentration of Fe (i.e. the sum of Fe^{3+} and Fe^{2+} concentrations) in the electrolyte. Similarly, the SOO of the negative electrolyte is defined as the ratio of the concentration of Cr^{2+} in the electrolyte to the total concentration of Cr (i.e. the sum of Cr^{3+} and Cr^{2+} concentrations) and may be expressed as a negative number. In equation form, these are:

$$\text{SOO}_{\text{pos}} = \text{Fe}^{3+} / (\text{Fe}^{3+} + \text{Fe}^{2+}) \quad [1]$$

$$\text{SOO}_{\text{neg}} = - \text{Cr}^{2+} / (\text{Cr}^{2+} + \text{Cr}^{3+}) \quad [2]$$

[0054] UNEQUAL MIXED REACTANT

[0055] Flow battery electrolytes may be formulated such that in both positive and negative electrolytes are identical in a fully discharged state. Such a system may be referred to as a “mixed reactant” system, an example of which is described in U.S. Patent No. 4,543,302. In some embodiments, a mixed reactant electrolyte that contains unequal concentrations of FeCl_2 and CrCl_3 in the initial electrolyte (fully discharged) may be used to minimize the inequality in concentrations of CrCl_2 and FeCl_3 , and to mitigate H_2 evolution during operation of a flow battery system. One example of the composition in the fully discharged state is 1M FeCl_2 /1.1M CrCl_3 /2–3M HCl. In such embodiments, the concentration of CrCl_3 is intentionally made higher than that of FeCl_2 in an initially-prepared and fully-discharged electrolyte solution. Upon charge, the SOO of CrCl_2 will be lower than that of FeCl_3 , thereby avoiding high SOO conditions at the Cr electrode where H_2 evolution is a greater problem. With this unequal mixed reactant, the Fe electrode may be charged to nearly 100% while the Cr electrode may be charged to a lower SOO.

[0056] The Fe ionic species (Fe^{3+} , Fe^{2+}) at the positive electrode have a total concentration $\text{Fe}_t = \text{Fe}^{3+} + \text{Fe}^{2+}$. Correspondingly, the Cr ionic species (Cr^{3+} , Cr^{2+}) at the negative electrode have a total concentration $\text{Cr}_t = \text{Cr}^{3+} + \text{Cr}^{2+}$. In embodiments of an unequal mixed reactant

electrolyte, Fe_t does not equal Cr_t , and the concentration of ionic species Fe^{3+} , Fe^{2+} , Cr^{3+} and Cr^{2+} vary widely with SOO.

[0057] The rate of H_2 evolution is enhanced at more negative potentials, which occurs as the Cr electrode becomes more fully charged. During charge, the ratio of the concentration of Cr^{2+} to the concentration of Cr^{3+} (i.e. Cr^{2+} / Cr^{3+}) increases, which is reflected in the more negative potential of the Cr electrode. By adding excess Cr^{3+} , this ratio will be lower and the potential of the Cr electrode will be less negative and H_2 evolution will be mitigated.

[0058] For example, the maximum charge that may be inputted to a cell with a mixed reactant with unequal concentrations of $FeCl_2$ and $CrCl_3$ at 0% SOO (fully discharged) of 1M $FeCl_2$ /1.1M $CrCl_3$ /2M HCl is limited by the lower concentration of the electroactive species in the anolyte or catholyte. In this case, the lower concentration is 1M $FeCl_2$. The effect of excess $CrCl_3$ on SOO may be seen in the following example. During charge, if nearly the entire 1M $FeCl_2$ is oxidized to $FeCl_3$, then PosSOO is nearly 100%. At the same time approximately the same amount (1M) of $CrCl_3$ is reduced to $CrCl_2$, making the NegSOO approximately 91% (1.0/1.1). In this example, the maximum SOO of the unequal mixed reactant composition is a function of the excess amount of $CrCl_3$ and the concentration of $FeCl_2$.

[0059] In some embodiments, an unequal mixed reactant may also provide advantages with respect to cell voltage. The cell voltage calculated using a Nernst potential relationship is 1.104 V for a cell containing equimolar mixed reactant (i.e. 1M $FeCl_2$ /1M $CrCl_3$ /1M HCl) that is charged to 90% SOO.

[0060] This may be compared with a cell with an unequal mixed reactant containing an excess of Cr^{3+} with a composition of 1M $FeCl_2$ /1.1M $CrCl_3$ /1M HCl. When the PosSOO is 90% for the positive electrode (Fe electrode), the negative electrode (Cr electrode) NegSOO is 81.8% and the cell voltage is 1.084 V. By adding a slight excess of Cr^{3+} , the cell voltage is lower by 20 mV and the SOO of the negative electrode is lower by about 8%. These two factors are beneficial for mitigating H_2 evolution at higher SOO, and help enhance energy efficiency.

[0061] Similar advantages may be achieved in flow battery electrolytes based on other redox couples in which parasitic side-reactions become increasingly likely as one electrode approaches a high SOO.

[0062] In some embodiments, if flow battery electrolytes contain unequal concentrations of total active materials, then a perfectly balanced pair of charged electrolytes will each contain equal amounts of both charged species (e.g., equal quantities of Fe^{3+} and Cr^{2+}), but the SOO of the two electrolytes will be different. For example, in an unequal mixed reactant Fe/Cr flow battery, the total concentration of Fe may be less than the total concentration of Cr (e.g., total Fe = 1.3 M and total Cr = 1.4 M in some embodiments). In such a system, the absolute value of SOO of the negative electrolyte may be smaller than the absolute value of SOO of the positive electrolyte even when the charged species are in balance. For example, if Cr^{2+} and Fe^{3+} are both 0.7M, the SOO of the negative electrolyte is $-0.7/1.4 = -0.50$; The SOO of the positive electrolyte is $0.7/1.3 = 0.54$.

[0063] The embodiments below include systems and methods for characterizing concentrations of dissolved reactant species in flow battery electrolytes, including systems and methods for quantifying electrolyte imbalance. Although many of the embodiments are described with reference to Fe/Cr flow batteries, the same principles and concepts may also be applied to other flow battery chemistries.

[0064] The various embodiments will be described in detail with reference to the accompanying drawings. Wherever possible, the same reference numbers will be used throughout the drawings to refer to the same or like parts. References made to particular examples and implementations are for illustrative purposes, and are not intended to limit the scope of the invention or the claims.

[0065] As illustrated in **FIG. 1**, some embodiments of an electrolyte concentration monitoring system **100** may be integrated into a redox flow battery system **102**. A redox flow battery system **102** such as that shown in **FIG. 1** may include electrolyte tanks **104** fluidically joined to a flow battery stack assembly **106**. In some embodiments, a redox flow battery system **102** may include four separate tank volumes that may be configured to keep charged electrolytes separated from discharged electrolytes. Such separated tank volumes may include four separate tanks or two tanks with dividers.

[0066] In some embodiments, a flow battery stack assembly **106** may include a plurality of electrochemical reaction cells configured for charging and discharging active species in the liquid electrolytes. Pumps **108** may be provided to pump electrolytes through the flow battery stack assembly **106** and any other connected systems, such as a rebalancing system **110** and/or an electrolyte concentration monitoring system **100**. In some embodiments, the redox

flow battery system **102** may be electrically connected to a power source **112** and/or an electric load **114**. A main flow battery system controller **116** may also be provided to control the operation of the redox flow battery system **102**, including the operation of pumps, valves, electrical connections, or any other electronic or electromechanical component within the redox flow battery system **102**.

[0067] IRON / CHROMIUM FLOW BATTERY ELECTROCHEMISTRY

[0068] The valence state of the Fe and Cr ionic species in an Fe/Cr flow battery changes between charge and discharge. Information on the concentration of the ionic species may be needed to determine the state-of-charge (SOC) of the battery and the electrolyte balance of the anolyte and catholyte. In some embodiments, the electric potential of an Fe/Cr flow battery cell may be used to monitor the SOC of the battery. A higher voltage suggests that the battery SOC is higher. However, the voltage of a flow battery cell may be ambiguous in that there are four ionic species in an Fe/Cr flow battery (Cr^{2+} , Cr^{3+} , Fe^{3+} and Fe^{2+}) that contribute to the cell voltage. In some embodiments, a more definitive measure of the SOC and concentration of the ionic species may be obtained by measuring the voltage of the anolyte and catholyte separately.

[0069] If charge and discharge are perfectly reversible, the cell is always in balance, with the same concentration of Fe^{3+} in the catholyte as Cr^{2+} in the anolyte. In reality, side reactions typically make the concentration of Fe^{3+} in the catholyte higher than that of Cr^{2+} in the anolyte. In this state, the system is said to be unbalanced and the energy storage capacity of the battery decreases. An unbalanced system must be appropriately rebalanced to regain the energy storage capacity. Insufficient rebalancing still leaves more Fe^{3+} in the catholyte than Cr^{2+} in the anolyte, leading to a condition that will be referred to herein as positive imbalance. Excessive rebalancing results in less Fe^{3+} than Cr^{2+} in the catholyte and anolyte respectively, leading to a condition that will be referred to herein as negative imbalance. In either case, the capacity of the cell is not fully regained.

[0070] In an ideal Fe/Cr redox flow battery, the overall electrochemical reaction during charging is:

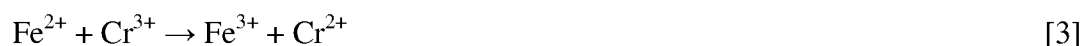

[0071] The Nernst equation gives the relationship between cell electric potential and electrolyte concentration.

$$E_{\text{cell}} = E^0 + (RT/nF) * \ln([\text{Fe}^{3+}][\text{Cr}^{2+}]/[\text{Fe}^{2+}][\text{Cr}^{3+}]) \quad [4]$$

[0072] In some embodiments, if the cell does not suffer from H₂ evolution or other side reactions, then the concentrations of Fe³⁺ and Cr²⁺ may be equal, and may be determined from the cell potential. However, with side reactions, the SOO of both catholyte and anolyte cannot be determined from cell potential measurement. To avoid issues related to the cell potential, separated half-cell redox potential measurements of the anolyte and catholyte may be made to determine the SOO of each electrolyte independently. Measuring the redox potential of the electrolyte may be carried out by using a reference electrode and an indicating electrode. Any suitable reference electrode, such as a calomel electrode or a silver-silver/chloride (Ag/AgCl) electrode may be used. Embodiments of suitable indicating electrodes include platinum, gold or carbon electrodes among others. These electrodes are all commercially available from Sensorex, for example.

[0073] In a measurement arrangement using both an indicating electrode and a reference electrode, the potential of the reference electrode is the same regardless of the concentration of various species in solution. But the potential of the indicating electrode varies linearly according to $\ln([\text{Fe}^{3+}]/[\text{Fe}^{2+}])$ in the catholyte, and $\ln([\text{Cr}^{2+}]/[\text{Cr}^{3+}])$ in the anolyte. However, measurements obtained using reference electrodes in a redox flow battery are subject to several sources of error and may be subject to measurement uncertainty on the order of 10 mV or more.

[0074] INTRODUCTION TO MONITORING

[0075] To control a rebalancing reaction so that it proceeds to the correct extent, it is desirable to know the concentrations of the charged form of the active species in the electrolytes (e.g., Fe³⁺ in the catholyte and Cr²⁺ in the anolyte). It may be sufficient in some embodiments to know the difference between the concentration of Fe³⁺ in catholyte, and that of Cr²⁺ in the anolyte. A very small, ideally zero, difference is usually desired.

[0076] Various techniques for monitoring the concentrations of reactants dissolved in liquid electrolyte are available, including measuring properties of the electrolyte such as redox potential, refractive index, density, concentration (e.g. by spectroscopic analysis) or various combinations of these.

[0077] TEST CELL STRUCTURE

[0078] In some embodiments, SOO and/or imbalance of electrolytes may be measured by placing electrolytes within a suitably configured test cell and monitoring changes in voltage, current, or other electrical quantities over time. A cross-sectional view of one embodiment of

a test cell **120** is shown in **FIG. 2**. As shown in **FIG. 2**, some embodiments of a test cell **120** may include first and second electrolyte chambers **122**, **124** with a separator membrane **126** in between. In some embodiments, each chamber **122**, **124** may be substantially occupied by a porous, conductive material such as a carbon or graphite felt material. In alternative embodiments as illustrated in **FIG. 3**, the first and second electrolyte chambers **122**, **124** may include shallow flow channels **128** separated by ribs **130** or any other structure configured to conduct electrons to and from the liquid electrolyte.

[0079] As shown in **FIG. 2**, the first electrolyte chamber **122** may include fluidic ports **132**, **134** and the second electrolyte chamber **124** may include fluidic ports **136**, **138**, respectively, through which electrolyte may flow into and/or out of the respective electrolyte chamber **122**, **124**. In some embodiments, a pair of the fluidic ports **134**, **138** may be joined by a fluid path **140** in fluid communication with one another such that electrolyte may be directed first as indicated at arrow **142** into the first electrolyte chamber **122** through fluidic port **132**, out of the first electrolyte chamber **122** second through fluidic port **134** through fluid path **140**, and third into the second electrolyte chamber **124** via fluidic port **138** before fourth exiting the test cell **120** via fluidic port **136** as indicated at arrow **144** in the second electrolyte chamber **124**.

[0080] In alternative embodiments, electrolyte as indicated by arrows **146**, **148** may be directed separately and in parallel respectively into fluidic ports **132**, **136** and then out of fluidic ports **134**, **138** as indicated by arrows **146**, **148**. Fluidic ports **132**, **134**, **136**, **138** may take any form and may be any shape and size as desired to deliver electrolyte into and out of the electrolyte chambers **122**, **124** of test cell **120**.

[0081] In some embodiments, one or both electrolyte chambers **122**, **124** may contain porous electrodes of carbon felt or other suitable flow-through electrode material. For example, any material that is conductive and inert in the electrolyte may be used as a porous or solid electrode that may be placed within or formed integrally with a portion of one or both cell chambers. In some embodiments, a surface of one or both electrodes may be treated, plated or otherwise coated with a catalyst material selected to promote desired reactions or to suppress undesired reactions. A test cell **120** may also include electrical terminals **180**, **182** for electrically connecting the test cell **120** to a power source or electric load **156**. The test cell **120** may include one or more bipolar plates or terminal plates **158**, **160** in contact with an electrode within the electrolyte chambers **122**, **124**, respectively.

[0082] FIGs. 3–4 illustrate exploded views of two embodiments of test cells 120. With particular reference to FIG. 4, a test cell 120 may include an upper body portion 162 and a lower body portion 164 that may be clamped, bolted, welded or otherwise sealed together, sandwiching a separator membrane 126 and any other desired components therebetween. In embodiments of a test cell 120 such as that shown in FIG. 4, the electrolyte chambers 122, 124 may be defined by cutouts 166 in a pair of removable chamber layers 168, 170. In some embodiments, the chamber layers 168, 170 may be made of a compressible gasket material, such as rubber or silicone. In other embodiments, chamber layers 168, 170 may be made of any other desired material, such as plastics or solid graphite. In some embodiments, chamber layers 168, 170 may be adhered to respective upper and lower body portions 162, 164. In other embodiments, chamber cavities may be machined, cast, molded or otherwise formed directly into the upper and lower body portions 162, 164, such as depicted in FIG. 3.

[0083] In some embodiments, the upper and lower body portions 162, 164 may be made of graphite, thus allowing upper and lower cell body halves 172, 174 themselves to be used as electrodes to measure the voltage of the test cell 120. In other embodiments, the upper and lower body portions 162, 164 may be made of any other material, electrical contact may be made with porous or other electrodes within the electrolyte chambers 122, 124. For example, the embodiment shown in FIG. 4 may include porous carbon felt electrodes 176, 178 configured to occupy the electrolyte chambers 122, 124.

[0084] In some embodiments, electrical terminals 180, 182 may be provided in electrical connection with each electrolyte chamber 122, 124. In some embodiments, if the entire cell body is conductive, the electrical terminals 180, 182 may be connected to the exterior of the cell body. Electrical terminals 180, 182 may be made of any suitable electrically conductive material. In some embodiments, each cell body half 172, 174 may include more than one electrode for measurement, charging, discharging or other purposes as will be described in further detail below.

[0085] As shown in FIG. 5, in some embodiments, the electrolyte chamber 122 may comprise an almond (or pointed oval) shape. The almond shape may facilitate flow conditions that may substantially prevent stagnation regions within the chamber 122 during flushing and filling of the test cell 120. In alternative embodiments, other chamber shapes may also be used

[0086] In some embodiments, the volumes of the electrolyte chambers **122**, **124** in a test cell **120** may be very small in order to shorten the measurement time. In some embodiments, the volumes of the two electrolyte chambers **122**, **124** may be substantially equal to one another. The volume of each electrolyte chamber **122**, **124** may be less than about 1 mL in some embodiments. In one particular embodiment, the volume of each electrolyte chamber **122**, **124** may be about 0.8 mL. In other embodiments, the electrolyte chambers of a test cell may be larger or smaller as desired.

[0087] In some embodiments as shown in **FIG. 3**, ribs **130** in the electrolyte chambers **122**, **124** may be used to further minimize electrolyte volume and/or to maintain the position of the separator membrane **126** such that the volumes of electrolyte in the two cell body halves **172**, **174** are substantially the same. However, equal electrolyte volumes in the test cell **120** are not necessary in all embodiments. In some embodiments ribs **130** may be included in an almond-shaped electrolyte chamber. One function of the ribs **130** may be to increase reaction surface area and to decrease the distance that an ion has to diffuse to reach the electrode surface.

[0088] In some embodiments the separator membrane **126** of the test cell **120** may be of a porous material. In other embodiments, the separator membrane **126** may be an ion selective membrane, such as a cation exchange membrane or an anion exchange membrane. In some embodiments, the selection of the porosity and/or selectivity of a separator membrane **126** may depend on the active materials under evaluation among other factors.

[0089] In some embodiments, an electrolyte concentration monitoring system **100** for detecting an imbalance such as those described herein may be provided as a stand-alone system configured to be independent of any redox flow battery system **102**. In other embodiments, an electrolyte concentration monitoring system **100** may be integrated into a redox flow battery system **102** as shown for example in **FIG. 1**. Various embodiments of flow-battery-integrated monitoring systems may be configured with different fluid delivery arrangements.

[0090] In some embodiments, a fluid delivery apparatus **190** may be provided to direct liquid electrolytes from a flow battery into the test cell **120**. As shown in **FIG. 1**, in some embodiments a test cell **120** may be joined in fluid communication with electrolyte conduits **184**, **186** downstream from electrolyte pumps **108**. In such embodiments, valves **188**, **189** may be provided to selectively direct electrolytes through the test cell **120** during normal pumping of electrolytes through the flow battery system **102**. In alternative embodiments,

fluidic connections for filling a test cell **120** may be independent of battery pumping apparatus. In some embodiments, a test cell fluid delivery apparatus may be configured to pump electrolytes directly from the tanks **104** into the test cell **120**.

[0091] In some embodiments, a fluid delivery apparatus **190** may be configured to fill a test cell **120** by parallel flow as shown by the solid arrows **146, 148** in **FIG. 2**. In parallel filling, both electrolyte chambers **122, 124** may be filled substantially simultaneously, with electrolyte exiting the electrolyte chambers separately as indicated by solid arrows **146, 148**. Alternatively, in some embodiments, if equal volumes of the two electrolytes are mixed, the test cell halves may be filled with the neutralized electrolyte in series as illustrated by the dashed arrows **142, 140, 144** in **FIG. 2**. During series filling, both electrolyte chambers **122, 124** may be filled in series by directing an outlet (fluidic port **134**) of the first electrolyte chamber **122** into an inlet (fluidic port **138**) of the second electrolyte chamber **124**. A parallel filling arrangement may provide lower flow resistance, while a series filling arrangement may provide improved assurance of electrolyte flow through both electrolyte chambers **122, 224**.

[0092] In some embodiments of a fluid delivery apparatus **190** as shown in **FIG. 6A**, the test cell **120** may be arranged in a through-flow configuration relative to an electrolyte flow conduit **191**. In a through-flow configuration, the test cell **120** may include separate inlet and outlet flow lines **192, 193**, both of which may be joined to an electrolyte flow conduit **191**. In some embodiments, a flow-through arrangement may include one or more pumps **194** to pull electrolyte from the electrolyte conduit and to push electrolyte through the test cell **120**. Any type of pump **194** may be used.

[0093] In some alternative embodiments, as shown for example in **FIG. 6B**, the test cell **120** may be arranged in a reciprocating flow arrangement relative to an electrolyte flow conduit **191**. In a reciprocating flow arrangement, the electrolyte may be taken from one point in an electrolyte conduit **191** and returned to the same point via reciprocating flow line **195**. In a reciprocating flow arrangement, a reciprocating pump **196**, such as a syringe pump may be used. In some embodiments, the stroke volume of a syringe pump may be substantially larger than the volume of the cell chambers and the tubing combined to ensure that the cell will be completely filled with fresh electrolyte. **FIGS. 6A – 6B** illustrate only one electrolyte flow channel for simplicity of illustration.

[0094] In some embodiments, in combination with any of the above-described fluidic arrangements, it may be desirable to mix positive and negative electrolytes prior to directing the neutralized electrolyte solution into the test cell **120**. In such embodiments, an electrolyte mixing device **197** may be included to mix electrolytes prior to injecting neutralized electrolyte into the test cell **120**. In some embodiments, an electrolyte mixing device may simply comprise a common section of electrolyte conduit. In other embodiments, electrolyte mixing devices **197** used in connection with a test cell filling apparatus may include any static or dynamic mixing device. In some embodiments, an electrolyte mixing device **197** may comprise a static mixer device such as those produced by Koflo Corp. (<http://www.koflo.com/>). In other embodiments, other static mixing structures, dynamic mixer bars or other mixing devices or structures may be used.

[0095] In some embodiments, an electrolyte concentration monitoring system **100** may include an electronic controller or electronic module **198** as shown for example in **FIG. 1**. An electronic module **198** may be configured to deliver an electrical current to the test cell in order to discharge and/or charge the electrolyte within the test cell **120** as described in more detail below. The electronic module **198** may also be configured to measure the open-circuit voltage (OCV) and/or the closed-circuit voltage (CCV) of the test cell at regular periodic time intervals. In some embodiments, an electronic module **198** may also be configured to control valves and/or a pump for filling the test cell **120**. In further embodiments, an electronic module **198** may be configured to control an active mixing device or any other electronic or electromechanical component within the electrolyte monitoring system. An electronic module **198** may be electrically connected to the test cell **120** at electric terminals **180**, **182** (e.g. in **FIG. 3** and **FIG. 4**).

[0096] In some embodiments, an electronic module **198** may include or consist of an analog circuit and a micro-computer controller. In some embodiments, the analog circuit may include or consist of a controlled current source and a signal conditioning circuit for reading voltages.

[0097] In some embodiments, a micro-computer controller may comprise one or more analog input channels to measure OCV or potential and at least one digital input channel for operator interfacing. In some embodiments, a micro-computer controller may also comprise a plurality of digital output channels to control pumps, valves and/or other electromechanical components. A micro-computer controller may also include at least one communication port, such as an industrial standard RS232 or USB port, in order to allow for communication

between the electronic module **198** and a main flow battery system controller **116**. Examples of suitable micro-computer controllers include: the open source ARDUINO architecture (<http://arduino.cc>), TEENSY (<http://pjrc.com/teensy>), and BASIC STAMP (<http://parallax.com>). Any other suitable micro-computer controller may also be used. Alternatively, all functions of the electronic module **198** may be incorporated into components within the main flow battery system controller **116**.

[0098] In some embodiments, an electronic module **198** of an imbalance and/or concentration monitoring system **100** may be controlled by the main flow battery system controller **116**. In some embodiments, the electronic module **198** may be configured with two states, “stand-by” and “busy.”

[0099] An example of an interaction between a main flow battery system controller **116** and an electronic module may include the following steps: (1) The main flow battery system controller **116** determines that the electronic module **198** is in standby mode, and then sends a command to the electronic module to begin a specified measurement process. (2) The electronic module **198** acknowledges receiving the command, and changes its state to “busy”. (3) The electronic module **198** may then execute steps to carry out the specified measurement process. (4) On completion of the measurement process, the electronic module **198** may perform data reduction steps, and may transmit data back to the main flow battery system controller **116**. (5) The electronic module **198** may then return to “standby” mode, at which point it stands ready to receive commands from the main flow battery system controller **116** to begin a new measurement process. Examples of various embodiments of measurement processes will now be described.

[0100] COULOMETRIC MONITORING METHODS

[0101] In some embodiments, the degree of imbalance of flow battery electrolytes (or the concentration of electrolyte reactants) may be measured by methods based on the concept of coulometric titration. Such methods are collectively referred to herein as coulometric methods. In some embodiments, coulometric methods of characterizing electrolyte reactant concentrations may generally benefit from mathematical relationships between charging or discharging time and electrolyte reactant concentrations as described below.

[0102] Various embodiments of coulometric methods may generally include placing approximately equal volumes of neutralized electrolyte (i.e. an electrolyte solution obtained by mixing together or substantially entirely discharging approximately equal volumes of

positive and negative electrolyte) into the test cell and then applying a charging current to the test cell while monitoring test cell voltage. As will be described in further detail below, the degree of imbalance of the electrolytes may be determined by measuring the time that elapses between the moment a known charging current is initiated until a pre-determined stop-point (e.g., a pre-determined voltage) is reached.

[0103] In some embodiments, neutralized electrolyte may be obtained by mixing substantially equal volumes of the anolyte and catholyte. When equal volumes of the positive and the negative electrolyte are mixed, the SOO of the resultant electrolyte is the average of the two individual electrolytes. In some embodiments, mixing of electrolytes may be performed in a vessel or flow channel prior to injecting the mixed (neutralized) electrolyte solution into a test cell. Alternatively, any of the mixing devices described above or equivalents thereof may be used.

[0104] Thus, in some embodiments, equal volumes of positive and negative electrolyte may be mixed together and the neutralized electrolyte may be injected into the two sides of a test cell. In such embodiments, after injecting electrolytes into the test cell, the same neutralized electrolyte solution will be present in both half-cell chambers of the test cell.

[0105] In alternative embodiments, neutralized electrolyte may be obtained by electrochemically discharging the electrolytes without necessarily mixing them in a batch process. In these alternative embodiments, instead of mixing the electrolytes, some volume of the positive electrolyte may be pumped through one electrolyte chamber 122 (FIG. 2) of the test cell 120, and some volume of the negative electrolyte may be pumped through the other electrolyte chamber 124 of the test cell 120. The volumes of positive and negative electrolytes pumped through the test cell 120 need not be equal. In some embodiments, the volumes of electrolytes pumped through the test cell 120 may be in excess of the volume of the respective half-cell compartments (electrolyte chambers 122, 124) so as to ensure that any excess liquid from previous tests is flushed out of the electrolyte chambers 122, 124.

[0106] In some embodiments, the electrolytes may then be discharged by short-circuiting the test cell 120, such as by electrically connecting the terminals 180, 182 of the two cell body halves 172, 174. In some embodiments, the test cell 120 may be connected to an electric load 114. The electrolytes in the electrolyte chambers 122, 124 may be discharged until eventually the test cell 120 reaches an open circuit voltage of approximately 0 V. At this point, the electrolytes in the two cell body halves 172, 174 of the test cell 120 will be

chemically the same as they would be if the electrolytes had been directly mixed in equal volumes. In other words, after discharging the test cell 120, the electrolyte in both electrolyte chambers 122, 124 will have an SOO that is the average of the two individual electrolytes.

[0107] In some cases, allowing the test cell 120 to discharge by a short circuit may take an undesirably long time. Thus, in some embodiments, the test cell 120 may be discharged by applying a discharge current. In some embodiments, a discharge current may be applied by repeatedly passing short-duration electric current pulses through the test cell 120 while regularly checking open-circuit-voltage of the test cell 120 in between current pulses. The pulsed-current discharge process may continue until the voltage measurement indicates that the test cell 120 has been discharged substantially to zero (or near enough to zero or less than about 0.002V in some embodiments). In some embodiments, an applied current of about 0.2A or higher may be used as a discharge current. In some embodiments, a higher current may discharge the electrolytes in the test cell 120 faster, but higher currents may also require faster electronics to monitor changes in cell voltage. In other embodiments, smaller discharge currents may be desirable. Thus, in some embodiments, the applied current may depend on the size of the test cell, among other factors.

[0108] Once both electrolyte chambers 122, 124 of the test cell 120 contain neutralized electrolyte, a charging current may be applied to the test cell. The change in cell voltage may then be monitored over time until the test cell OCV or CCV reaches a pre-determined value (or until another stop-point is reached). The total charging time between initiating a charging current and the test cell 120 reaching the pre-determined end-point may be correlated to the degree of imbalance as described in further detail below.

[0109] Embodiments of a coulometric imbalance measurement process for an Fe/Cr flow battery will now be described with reference to FIGs. 7A – 7F. Although the following examples are given with reference to an Fe/Cr redox couple, the same principles will apply to substantially any other redox couple.

[0110] In the case of an Fe/Cr flow battery, the standard reduction potentials are:



[0111] The potential of each electrolyte may be determined from the Nernst equation as a function of the ratio of uncharged to charged concentration. For example:

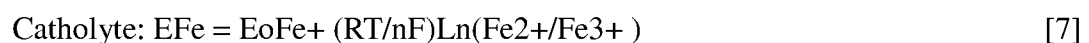

$$\text{Anolyte: } E_{\text{Cr}} = E_{0\text{Cr}} + (RT/nF)\ln(\text{Cr}^{2+}/\text{Cr}^{3+}) \quad [8]$$

[0112] For the special case of a perfectly discharged electrolyte, the entire concentration of the active species will be in their discharged forms. As a result, the second term of the Nernst equations becomes undefined. In most such cases, the potential of each electrolyte is about half the sum of the standard redox potentials:

$$E = (E_{0\text{Fe}} + E_{0\text{Cr}})/2 \quad [9]$$

[0113] Thus, by using equations [5] – [9], the theoretical potential at any state of oxidation may be calculated for a pair of flow battery electrolytes. The double-S shaped curve 200 of FIG. 7A – 7C is a graph of electric potential vs. charged-species concentration difference (i.e. $\text{Fe}^{3+} - \text{Cr}^{2+}$) for an Fe/Cr redox couple. The examples of FIGs. 7A – 7E assume that the total concentration of each active material is the same in both electrolytes (e.g., that total Fe = total Cr = 1M). The corresponding graphs for embodiments with unequal total concentrations will be qualitatively similar, but the positive and negative plateaus will be of different widths.

[0114] The imbalance of the electrolytes may be defined in terms of concentration as the difference between the concentration of Fe^{3+} in the positive electrolyte and that of Cr^{2+} in the negative electrolyte. In a perfectly balanced system, the concentration of Fe^{3+} in the positive electrolyte is equal to the concentration of Cr^{2+} in the negative electrolyte, and the imbalance is zero. Thus, the horizontal axis of the charts in FIGs. 7A – 7C may also be labeled “imbalance.”

[0115] FIGs. 7A - 7D illustrate the theoretical relationship between electrolyte concentration difference ($\text{Fe}^{3+} - \text{Cr}^{2+}$) and electric potential (V) of the positive electrolyte (represented by positive values to the right of zero) and negative electrolyte (represented by negative values to the left of zero). If the electrolytes are balanced (and total Fe = total Cr), the concentration difference of the positive electrolyte will be equal in magnitude and opposite in sign to the concentration difference of the negative electrolyte.

[0116] When positive and negative electrolytes are neutralized (as described above), the catholyte concentration difference decreases (moves to the left) and the anolyte concentration difference increases (moves to the right), until the two concentration difference values meet at a point equal distance in x coordinate from the two original points. If the imbalance is zero, the final point is the midpoint of the double S curve 200, as indicated by the diamond 202 at the center of FIG. 7A. The diamond 202 also represents the midpoint between the starting

SOO values of the anolyte and catholyte indicated by the squares 204, 206. The maximum slope of the double S curve 200 occurs at the point at which $SOO = 0$.

[0117] As shown in FIG. 7B, when the imbalance is greater than zero (i.e. positive imbalance), the final point 210 after SOO-averaging the electrolytes is still an equal distance in x coordinates from the two original points 212, 214, but it is not the mid-point of the double S curve 200. As shown, the final point 210 for a neutral electrolyte of this positively unbalanced electrolyte is shifted to the right of zero on the double S curve 200. (If the electrolyte were negatively unbalanced by the same amount, the final point 210 would be shifted an equal distance to the left of zero on the curve 200). To test the degree of imbalance of this solution within a test cell 120, a charging current may be applied to the test cell 120. At this point, the solution in the positive chamber of the test cell 120 becomes representative of the catholyte, and the solution in the negative chamber of the test cell becomes representative of the anolyte.

[0118] As the test cell 120 is charged, the cell voltage (which is the difference between the positive electrolyte potential and the electrolyte negative potential) will increase as the positive electrolyte concentration difference moves to the right and the negative concentration difference moves to the left from the midpoint (final point 210) along the double S curve 200. As shown in FIG. 7C, as the test cell 120 is charged, the catholyte concentration difference increases from point P1 to point P2 to point P3, while the anolyte concentration difference decreases from point N1 to point N2 to point N3. As the concentration difference values move through these points, the test cell OCV will remain close to zero for a period of time, and will then rise sharply as the concentration difference of the negative electrolyte approaches zero. In some embodiments, this point (i.e. the point at which the concentration difference of the negative electrolyte is substantially equal to zero) is the point at which the time measurement should be stopped, since this is the point at which all the excess charged reactant species in the neutralized electrolyte has been converted (i.e., oxidized or reduced) to its discharged form (e.g., all Fe^{3+} has been reduced to Fe^{2+}). Methods of identifying this end-point during measurement will be described in more detail below.

[0119] As shown in FIG. 7D, the slope of the OCV versus change in concentration difference curve 220 dramatically increases at about the point representing an excess Fe^{3+} concentration of 0.2. The slope of the OCV versus time curve 230 will be similarly shaped in FIG. 7E, and will reach a maximum at the point that corresponds to one of the electrolyte concentration differences passing through zero in the double S curve 200 of FIGs. 7A – 7C.

[0120] By contrast, FIG. 7F illustrates an OCV versus change in concentration difference curve 240 for the balanced electrolyte of FIG. 7A. In this case, because the starting concentration difference is zero, the cell potential immediately increases dramatically before the slope decreases as the charged species concentrations depart from zero.

[0121] FIG. 7G is a graph 250 of electrolyte potential versus concentration difference for an Fe/Cr flow battery system, with points illustrating a negatively unbalanced electrolyte solution.

[0122] When a pre-determined end-point is reached, the charging may be stopped, and the total charge time may be determined. In some embodiments, the cell may be charged by alternately applying charge current pulses and switching off the charging current to measure OCV. For example, in some embodiments, a pulsed charging current may be cycled between applying a current for 0.4 second and switching off the current for 0.1 second. In such an example, a charging current is applied for eight tenths (80%) of each second. Thus, a total charge time may be obtained by multiplying a total elapsed time (i.e., the time between initiating a charge and reaching an end-point) by the proportion of time during which current is applied (i.e., 80% in the above example).

[0123] Charging the cell at a known current for a measured amount of time (t) in seconds, the cumulative quantity of charge (i.e., the number of Coulombs, 'C') introduced into the electrolytes may be calculated based on the definition of electric current (I):

$$C = t * I$$

[10]

[0124] The number of moles ('M') of charged electrolyte species corresponding to the cumulative charge may be obtained by dividing the charge by the Faraday constant ('F'):

$$M = C / F$$

[11]

[0125] This provides the number of moles of the excess charged electrolyte species in the neutralized electrolyte. Because the selected measurement end-point ideally represents the point at which the non-excess electrolyte concentration difference is zero, the number of moles calculated in equation [11] represents the number of moles of excess charged ions in the neutralized electrolyte. Dividing M by the known volume of one test cell chamber provides the molar concentration of the excess species in the neutralized electrolyte. The imbalance of the system is the difference between Fe³⁺ in the catholyte and Cr²⁺ in the

analyte. This is twice the amount of the excess species in the final neutralized electrolyte. Therefore the system imbalance is twice the molar concentration of the excess species.

[0126] FIG. 8 illustrates a graph 260 of several examples of test cell voltage versus time relationships using samples with known excess concentrations of Fe^{3+} / Cr^{2+} in a prototype test cell. The voltage versus time and voltage versus SOO change relationships will vary depending on specific characteristics of the test cell, including the cell's electrical resistance, the volume of the electrolyte chambers, the type of separator membrane used, and other factors.

[0127] In some embodiments, a reference electrode may be useful in distinguishing positive imbalance in which $[\text{Fe}^{3+}] > [\text{Cr}^{2+}]$ from negative imbalance in which $[\text{Cr}^{2+}] > [\text{Fe}^{3+}]$. A practical reference electrode 300 as shown in FIGs. 9A – 9B typically has its own internal solution, the concentration of which remains constant. This gives a constant potential of the reference electrode 300. The internal solution may be placed in contact with a sample electrolyte 302 through a junction made of a porous material, as shown for example in FIG. 9B.

[0128] Some reference electrodes may not be stable in long term contact with liquid electrolytes because the electrolyte being measured can leak into the reference electrode chamber and mix with the reference electrode's internal solution, thereby degrading the accuracy of the measurement. In some embodiments, a reference electrode for long-term use in a redox flow battery electrolyte may be constructed with features designed to limit the rate of migration of electrolyte liquid into the internal solution of the reference electrode. In general, such features may include a leak path that is relatively long and/or has a relatively small cross-sectional area. Additionally, well-sealed chambers may be further beneficial.

[0129] In FIG. 9C, a reference electrode 300 may be incorporated with an imbalance or electrolyte concentration monitoring system test cell 100 such as those described herein by placing the reference electrode in contact with at least one electrolyte somewhere in the flow path. In some embodiments, the point of contact does not need to be inside the imbalance test cell (although, it may be), and may be either in the flow path of the catholyte or the anolyte, either up-stream or down-stream from the cell.

[0130] In some embodiments, measurement of the potential of either the positive or the negative electrolyte may be made with respect to the reference electrode. The value of such a measurement may unambiguously determine whether the system has positive or negative

imbalance. Although measurement with a reference electrode is not highly accurate, and may be subject to an uncertainty on the order of 10 mV, such uncertainty does not affect the use of the reference electrode for this purpose. This is because the cases of positive and negative imbalance give very different potential of the neutralized electrolyte. Because the middle section of the double S curve is very steep, a small difference in concentration corresponds to a large difference in OCV. For example, a positive imbalance of +0.005M and a negative imbalance of -0.005M results in about 0.7V difference in the potential.

[0131] With the internal solution of the reference electrode in contact with the test electrolyte through a porous junction, the chemical species in the test electrolyte will diffuse into the internal solution of the reference electrode over time, negatively affecting its accuracy. This may be greatly delayed by using reference electrode with multiple junctions, as shown in FIG. 9B. In some embodiments, a reference electrode with three or more junctions may also be used.

[0132] In various embodiments, the pre-determined end-point at which the time measurement is stopped may be based on different parameters. In some embodiments, the end point may be a voltage value may be based on a pre-determined value of either the closed circuit voltage (CCV) or open circuit voltage (OCV) of the cell. If CCV is used as the criterion, the charging current may be applied and CCV may be measured continuously. This may simplify the electronic module 198. If OCV is used as the criterion, the end point may be sharper and the accuracy may be improved, but the charging current must be applied in a pulsed manner such that OCV may be measured at regular intervals.

[0133] In some embodiments, a pre-determined end-point cell voltage (OCV or CCV) may be determined based on the known theoretical relationship between voltage and electrolyte concentration as shown and described above with reference to FIGs. 7A – 7F. For example, as shown in FIG. 7D when change in Fe^{3+} – Cr^{2+} is near 0.2 M, the test cell OCV changes sharply. This indicates that 0.2 M is the end point. In some embodiments, an end-point voltage may be at least 0.5 V. In some particular embodiments, an end-point voltage may be about 0.55 V, 0.65 V or about 0.7 V. In some embodiments, the ideal end-point voltage may change over time due to changing resistance of the test cell. Such changes may be identified by calibration and appropriate adjustments to end-point voltage or other adjustments may be made. Different end-point voltage values may be implied by voltage/concentration curves for different redox couples.

[0134] In other embodiments, a time measurement end-point may be based on a point at which the slope of the measured voltage vs. time curve reaches a maximum. For example, in some embodiments, measurement data (e.g., OCV and elapsed time) may be sampled and stored in a digital memory during a single test. Such measurement data may be analyzed by a processor to identify a maximum voltage vs. time slope. In some embodiments, the maximum slope may only be identifiable after it has passed. In such embodiments, the end-point time may be identified and applied retroactively.

[0135] In some embodiments, both a threshold voltage and a peak slope may be used to identify a measurement time end-point. For example, in some embodiments a processor may begin analyzing data to identify a maximum voltage vs. time slope only after a threshold voltage has been reached. In other embodiments, the calculation of a maximum slope may utilize other related quantities, such as voltage versus coulombs or others.

[0136] In some embodiments, a coulometric monitoring method may comprise the following operations: (1) Mix equal volumes (e.g. about 5 mL each in one embodiment) of positive and negative electrolyte; (2) Fill both chambers of the test cell with the neutralized electrolyte solution, flushing out any previously-present liquid from the test cell; (3) Apply a charging current to the test cell (e.g. about 0.2A in one embodiment); and (4) Measure time until the voltage of the test cell reaches a desired set point (e.g. about 0.6 V in one embodiment). (5) Calculate a degree of electrolyte imbalance based on the coulombs of charge transferred to the electrolyte. Alternatively, Step (4) may comprise measuring time until the slope of a voltage versus time curve reaches a maximum or exceeds a pre-determined threshold.

[0137] In alternative embodiments, a coulometric monitoring method may comprise the following steps: (1) Fill each chamber of the test cell with a respective positive or negative electrolyte; (2) Discharge the test cell to approximately zero volts (e.g. by a short-circuit, by connecting a load, or by applying a pulsed discharge current); (3) Apply a charging current to the test cell (e.g. about 0.2A in one embodiment); and (4) Measure time until the voltage of the test cell reaches a desired set point (e.g. about 0.6 V in one embodiment). (5) Calculate a degree of electrolyte imbalance based on the coulombs of charge transferred to the electrolyte. Alternatively, Step (4) may comprise measuring time until the slope of a voltage versus time curve reaches a maximum or exceeds a pre-determined threshold.

[0138] In some embodiments, the system may be calibrated using these steps with

electrolytes of a known imbalance. For example, an electrolyte solution may be prepared with concentrations of total active materials identical to a flow battery system to be monitored. Such a solution may be prepared with a known excess quantity of one charged active species (e.g., with a known unbalanced ratio of Fe³⁺ to Cr²⁺). Alternatively, only one standard solution may be used to avoid difficulties in creating the neutralized electrolyte that is made by mixing two electrolytes and in keeping a Cr²⁺ solution with an accurate concentration. By testing such a known imbalanced electrolyte in a test cell, the test cell may be calibrated by applying a calibration constant to correct any systematic error between an imbalance measured by the test cell and the known imbalance of the test sample.

[0139] EXAMPLE OF IMBALANCE MEASUREMENT OPERATION AND CALCULATION

[0140] In FIG. 7E, a curve 230 of OCV as a function of time is depicted. The volume of an imbalance test cell is 0.8 mL on each side. When the cell is flushed with excess amount of electrolytes to be tested, 0.8 mL of each electrolyte (catholyte and anolyte) is retained in the cell. The cell is discharged until OCV is < 0.002 V five (5) seconds after open circuit starts. Then the cell is charged with 0.2A pulses. The pulse is turned for 0.4 seconds and turn off for 0.1 seconds. During the 0.1 second of open-circuit, the OCV is measured. Thus the current is turned on 80% of the time. This process of alternately charging and monitoring is then continued. When a time 24 seconds has elapsed, the OCV has reached 0.854 V and the charging is stopped. The curve of OCV versus time may be constructed on reviewing the data. The OCV versus time curve 230 for this example is shown in FIG. 7E.

[0141] The slope of the curve 230 is the steepest at time = 23.5 s, which corresponds to the end point of the charging. During the 23.5 seconds, the current was on 80% of the time. Thus, the total charge time was:

$$23.5 \text{ seconds} \times 80\% = 18.8 \text{ seconds.}$$

[0142] Since the current was 0.2A, the cumulative total charge is:

$$0.2 \text{ A} \times 18.8 \text{ s} = 3.76 \text{ Coulombs}$$

[0143] The number of moles corresponding to this is obtained by dividing the cumulative total charge by the Faraday constant:

$$3.76 \text{ C} / (96487 \text{ C/mol}) = 3.90\text{E-}5 \text{ moles}$$

[0144] Dividing by the volume of one electrolyte chamber of the test cell gives the concentration of Fe³⁺ in the neutralized electrolyte (assuming the imbalance is known to be

positive imbalance):

$$3.90\text{E-}5 \text{ moles} / 0.0008 \text{ L} = 0.0487 \text{ M}$$

[0145] The imbalance of the system is the difference between Fe^{3+} in the positive electrolyte and Cr^{2+} in the negative electrolyte. This is twice the amount of Fe^{3+} in the final neutralized electrolyte. Therefore the imbalance is:

$$0.049 \text{ M} \times 2 = 0.0974 \text{ M.}$$

[0146] The imbalance may also be expressed as a %, assuming the electrolyte is 1.3M in both Fe and Cr, then the % imbalance is:

$$0.0974 \text{ M} / 1.3 \text{ M} = 7.5\%$$

[0147] SINGLE REACTANT CONCENTRATION MEASUREMENT USING A REFERENCE ELECTRODE

[0148] In some embodiments, the concentration of a single charged electrolyte reactant may be measured in a test cell. In some embodiments, such measurements may use a reference electrode measurement as described above. For example, using a reference electrode and a test cell, the concentrations of Fe^{3+} and/or Cr^{2+} may be determined individually. In some embodiments, anolyte and catholyte are not pre-mixed before filling the cell. In other words, the positive and negative electrolyte chambers of the test cell should be filled with catholyte and anolyte individually, then discharged at a known (e.g., measured or controlled) current to substantially near zero OCV. The individual concentrations of Fe^{3+} and Cr^{2+} may be determined from the curve of OCV vs. change in charged electrolyte concentrations (e.g., change in $\text{Fe}^{3+} - \text{Cr}^{2+}$) while discharging the separate electrolytes in the test cell. Thus, although current during discharge of the test cell does not need to be known when only measuring imbalance, by monitoring or controlling the current during discharge of the test cell, the concentrations of Fe^{3+} and Cr^{2+} may be measured with minimal additional effort. In any case, the discharge current need not be constant.

[0149] FIGs. 10A and 10B illustrate an example of graphical results 400 and 402, respectively, such a process for a system with positive imbalance. The original catholyte and anolyte in respective chambers of a test cell are represented by points P0 and N0. While discharging the test cell, the two electrolytes move toward each other along the double S curve 404. The positive electrolyte moves progressively along the curve 404 from point P0 to P1, P2, P3 and P4, and at the same time the negative electrolyte moves along the curve from point N0 to N1, N2, N3 and N4 in that order. The horizontal dashed line represents the

potential measured by an Ag/AgCl reference electrode.

[0150] Using a reference electrode and the test cell OCV, the potentials of the positive and the negative electrolytes in the positive and negative test cell halves may be measured throughout the discharge process. From FIGs. 10A and 10B, it may be seen that the potential of the positive half-cell changes little from P0 to P4. By contrast, the potential of the negative half-cell changes little from N0 to N2, but rises sharply at N3. FIG. 10B illustrates a chart of potential (i.e., half-cell potentials relative to the reference potential) vs. change in charged reactant concentration (e.g., Fe^{3+} - Cr^{2+}). As will be clear in view of the above discussion, the x-axis of FIG. 10B is directly related to discharge time when discharging of the test cell proceeds at a known current.

[0151] In contrast to the above embodiments of imbalance measurements by coulometric titration, the methods of the present embodiments may measure the concentrations of both charged electrolyte species (e.g., Fe^{3+} and Cr^{2+}) in a single test cell discharge/charge process in addition to measuring the imbalance. As described above, if only imbalance is to be measured, the test cell may be discharged to substantially 0V to obtain a starting point. In such cases, coulombs need not be counted during the discharge phase. The electrolytes may be physically mixed to obtain the same result as discharging, which would also preclude counting coulombs. By contrast, single reactant concentration measurements may involve measuring two out of three related quantities (i.e., the concentration of each charged species and the imbalance).

[0152] For instance, in a positively imbalanced pair of electrolytes, Cr^{2+} concentration and the imbalance may be measured, from which the concentration of Fe^{3+} may be calculated. In some embodiments in which coulombs are counted during discharge, the discharge stage may have two end points. For example, a first discharge end point may be the point at which a sudden jump in the measured potential of the negative half-cell versus the reference potential occurs. The second discharge end point may be the point at which the cell OCV is substantially zero (similar to the embodiments of imbalance-only measurements described above). Coulombs may be measured between a starting point and the first end point to calculate Cr^{2+} concentration. However, coulombs need not be measured for the second discharge phase between the first end point and the second end point. From that point, the test cell may be charged, and coulombs may be measured during charging to calculate imbalance as described above with reference to embodiments of imbalance measurement methods.

[0153] In FIG. 10B, the potential of the negative half of the cell (filled with anolyte) rises sharply at $X = 0.3$. Up to this point, the potential of the positive half of the cell (filled with catholyte) has changed little. This suggests that there is more Fe^{3+} than Cr^{2+} in the system, and that the Cr^{2+} concentration in the original anolyte is 0.3 M. The discharge continues until OCV reaches nearly zero. At this point the electrolytes are essentially neutralized. The imbalance in the electrolytes (e.g., $\text{Fe}^{3+} - \text{Cr}^{2+}$) may be determined by any of the imbalance measurement embodiments described above using the neutralized electrolyte in the same test cell. Once the concentration of the anolyte reactant (e.g., Cr^{2+}) is known and the imbalance is known, the Fe^{3+} concentration may be calculated from $\text{Fe}^{3+} = \text{imbalance} + \text{Cr}^{2+}$.

[0154] FIGs. 10C–10D illustrate an example with graphical results 420, 422, respectively, of a similar process for a system with negative imbalance. In FIG. 10C, the original catholyte and anolyte are represented by points P0 and N0, respectively. As the test cell is discharged, the two electrolytes move toward each other along the curve 404. The positive electrolyte moves progressively from point P0 to P1, P2, P3 and P4, and at the same time the negative electrolyte moves progressively from point N0 to N1, N2, N3 and N4. The horizontal dashed line represents the potential measured by the reference electrode.

[0155] Using a reference electrode and the test cell OCV, the potentials of the positive and the negative half of the test cell may be measured throughout the discharge process. From FIGs. 10C and 10D, it may be seen that the potential of the negative half-cell changes little from N0 to N4, while the potential of the positive half-cell changes little from P0 to P2, but drops sharply at point P3. FIG. 10D illustrates a chart of the potential (i.e., half-cell potentials relative to the reference potential) vs. change in charged reactant concentration (e.g., $\text{Fe}^{3+} - \text{Cr}^{2+}$) As will be clear in view of the above discussion, the x-axis of FIG. 10D is directly related to discharge time when discharging of the test cell proceeds at a known controlled current.

[0156] In FIG. 10D, the potential of positive half of the cell (filled with catholyte) drops sharply at $X = 0.3$. Up to this point, the potential of the negative half of the cell (filled with anolyte) has changed little. This suggests that there is more Cr^{2+} than Fe^{3+} in the system, and that the Fe^{3+} concentration in the original catholyte is 0.3 M. The discharge continues until OCV reaches nearly zero. At this point the electrolytes are essentially neutralized. The imbalance in the electrolytes (e.g., $\text{Fe}^{3+} - \text{Cr}^{2+}$) may be determined by any of the imbalance measurement embodiments described above using the now-neutralized electrolyte in the same test cell. Once the concentration of the catholyte reactant (e.g., Fe^{3+}) is known and the

imbalance is known, the Cr^{2+} concentration may be calculated from $\text{Cr}^{2+} = \text{Fe}^{3+} -$ imbalance.

[0157] SINGLE REACTANT CONCENTRATION MEASUREMENT WITHOUT A REFERENCE ELECTRODE

[0158] In some embodiments, the concentration of a single electrolyte reactant may be measured without the use of a reference electrode by placing only that electrolyte into both electrolyte chambers of a test cell. For example, the concentration of Fe^{3+} in the catholyte may be measured by placing only the catholyte (without anolyte) in a test cell. Alternately, the concentration of Cr^{2+} in the anolyte may be measured by placing only the anolyte (without catholyte) in the test cell.

[0159] FIG. 11A illustrates a graph 500 mainly the catholyte half of the double S curve for an Fe/Cr redox couple. A catholyte with Fe^{3+} concentration = 0.3M is represented by point 0. Both electrolyte chambers of a test cell may be filled with this catholyte. Since the same electrolyte is in both sides, the OCV is initially zero. The cell may then be charged with a controlled current while the OCV is measured vs. time. The time value may be converted to an equivalent concentration of Fe^{3+} using the equations described above. During charging, electrolyte on the positive side of the test cell progressively passes through points P1, P2 and P3 while the electrolyte in the negative side progresses through points N1, N2, and N3.

[0160] The measured OCV represents the difference between the potentials of the positive and the negative halves of the cell. FIG. 11C illustrates a graph 502 of the OCV vs. the concentration change (i.e., the change in Fe^{3+} from the start of the test at point 0). A sharp rise in the OCV is observed at a concentration difference of $\text{Fe}^{3+} = 0.3$. This indicates that the concentration of Fe^{3+} in the original catholyte is 0.3M.

[0161] FIG. 11B and FIG. 11D illustrate graphs 504, 506, respectively, a similar embodiment for measuring the concentration of Cr^{2+} in the anolyte. FIG. 11B illustrates mainly the anolyte half of the double S curve. An anolyte with Cr^{2+} concentration = 0.3M is represented by point 0. Both electrolyte chambers of a test cell may be filled with this anolyte. Since the same electrolyte is in both cell compartments, the OCV is zero. The cell may then be charged with a controlled current while the OCV is measured vs. time. The time value may be converted to an equivalent concentration of Cr^{2+} using the equations above. During charging, the electrolyte in the positive side of the test cell progressively passes through points P1, P2 and P3 in that order while the electrolyte in the negative side

progresses through points N1, N2, N3.

[0162] The measured OCV is the difference between the potentials of the positive and the negative half of the cell. FIG. 11D illustrates 506 a graph of OCV vs. the change in Cr^{2+} (i.e. the change in concentration difference from the start of the test at point 0). A sharp rise in the OCV is observed at change in $\text{Cr}^{2+} = 0.3$. This indicates that the concentration of Cr^{2+} in the original analyte is 0.3M.

[0163] The above examples illustrate measurement of the concentration of a reactant (e.g., Fe^{3+}) in catholyte using only catholyte, and measurement of the concentration of a reactant (e.g., Cr^{2+}) in the anolyte using only anolyte in the test cell. In either case, no reference is needed. The imbalance of the two electrolytes may then be obtained as the difference between the redox reactant (i.e., $\text{Fe}^{3+} - \text{Cr}^{2+}$).

[0164] However, in the measurement of individual concentrations without the use of a reference electrode, there are two limitations. The identity of the electrolyte being tested must be known independent of the test. A catholyte with $\text{Fe}^{3+} = 0.3\text{M}$ cannot be distinguished from an anolyte with $\text{Cr}^{2+} = 0.3\text{M}$. As a result, the curve in FIG. 11B is very similar to that in FIG. 11D.

[0165] The SOO of the catholyte or the anolyte should be less than about 0.4 to use this method. Otherwise the measured OCV curve may give a false result that folds over around $\text{SOO} = 0.5$. This means that if the total Fe concentration is 1.0, then a catholyte with $\text{Fe}^{3+} = 0.7$ is indistinguishable from that with $\text{Fe}^{3+} = 0.3$; 0.8 is indistinguishable from 0.2, etc. The same applies to the anolyte.

[0166] EXAMPLES OF CONTROL PROCESSES

[0167] FIGs. 12A – 14B provide examples of control process embodiments that may be controlled by an electronic module 198 as described above with reference to FIG. 1. The numeric time values provided in FIGs. 12A, 13A and 14A are provided primarily for reference and simplicity of explanation. Actual times may vary substantially from these values and may depend on many factors such as the time response of various system components.

[0168] FIG. 12A is a process flow diagram 600 illustrating an embodiment of a control process that may be executed by an electronic module 198 to control an imbalance measurement process using an electrolyte monitoring system with a through-flow fluid delivery system 602 as illustrated for example in FIG. 12B. The process s of FIG. 12A

comprises the steps numbered 1 – 8, which may occur at the approximate times in the second column.

[0169] At the start of the measurement process of FIG. 12A, all valves V1, V2, V3 and V4 are all opened in step 1 at time $t = 0$. Step two may begin once all valves are open, which may be at about time $t = 0.1$ minutes. During step two, both pumps P1 and P2 may be started to pump electrolyte through the cell 120. Step two may proceed for a sufficient time and at a sufficient pump flow rate to flush out all electrolyte previously in the test cell 120 and in all tubing of the fluid delivery system 602. Once the test cell 120 is full of fresh electrolytes, the pumps may be shut off at step 3 which may be at a time of about $t = 1.9$ minutes, and the valves may be closed (step 4) at $t = 2$ minutes.

[0170] The test cell may then be discharged in a discharge process (step 5) that may begin at about time $t = 2.1$ minutes. The discharge process (step 5) may continue until a desired near-zero OCV is reached, e.g. about 0.002 V in some embodiments. The time interval needed to discharge the test cell to the desired near-zero point will be variable and is therefore represented in FIG. 12A by the variable 'X'. The variable discharge time 'X' may depend on the value of the desired near-zero OCV, the value of an applied current, the degree of electrolyte imbalance, the SOO of the respective electrolytes, and other factors. As discussed above, some of these variable factors may be known, and in some embodiments the variable discharge time ('X') may be measured and evaluated to determine a reactant concentration. In some embodiments, the timer interval X may be a few seconds up to about three (3) minutes. In some embodiments, the discharge process may be stopped and a charging process may be started (step 6) at a time of about $t = X + 2.1$. As discussed above, the time interval for the charging process (step 6) will also be variable, and may proceed until a desired measurement end-point is reached. The variable test cell charge time is represented as 'Y' in FIG. 12A. Thus, the charging process may be stopped at time $t = X + Y + 2.1$ minutes. In some embodiments, Y may be a few seconds up to about 4 minutes or more.

[0171] Once the time interval Y is determined at the completion of step 7, the electronic module 198 may calculate the imbalance from the value of the time interval Y and other known system variables and constants as described above. In some embodiments, the electronic module may then communicate a measured imbalance value back to the main flow battery control system.

[0172] FIG. 13A is a process flow diagram 700 illustrating an embodiment of a control

process that may be executed by an electronic module 198 to control an electrolyte reactant concentration measurement process using an electrolyte monitoring system with a through-flow fluid delivery system 702 configured to direct only one electrolyte through the test cell 120 as illustrated for example in FIG. 13B. The process of FIG. 13A will now be described with reference to the catholyte of an Fe/Cr flow battery electrolyte. In some embodiments, the same process may be performed to make a corresponding measurement of the concentration of a charged reactant concentration in an anolyte. In some embodiments, the catholyte concentration measurement process and the anolyte concentration measurement process may be performed simultaneously in separate test cells, which may be located adjacent respective electrolyte storage tanks in some embodiments.

[0173] The process of FIG. 13A may begin at time $t=0$ by opening both valves V1 and V2. At time $t = 0.1$ minutes, the pump P1 may be turned on (step 2), and catholyte may be pumped through the test cell 120 for a sufficient time and at a sufficient flow rate to flush out all electrolyte previously in the test cell and all tubing of the fluid delivery system 702. In some embodiments, the pumps may be stopped (step 3) at about time $t = 1.9$ minutes, and both valves V1 and V2 may be closed (step 4) at about time $t = 2.0$ minutes. Once filled with a single electrolyte, the test cell 120 may have an OCV of zero. The test cell 120 may be charged (step 5) beginning at time $t = 2.1$ minutes. The test cell 120 may be charged until a desired end-point is reached as described above. As the test cell 120 is charged, the test cell OCV will increase from zero and the rate of OCV change will eventually reach a maximum before slowing down again. In some embodiments, the end-point may be the point at which the rate of OCV change versus time reaches a maximum before slowing down again. The charging time interval variable is represented by 'X' in FIG. 13A. Charging may be stopped (step 6) once the end-point is reached at time $t = X+2.1$. The electronic module may then calculate the charged electrolyte concentration (e.g., Fe³⁺), and may communicate the measured concentration value to the main flow battery control system.

[0174] FIG. 14A is a process flow diagram 800 illustrating an embodiment of a control process that may be executed by an electronic module to control an electrolyte reactant concentration measurement process and an imbalance measurement using an electrolyte monitoring system with a through-flow fluid delivery system 802, a reference electrode 'RE', and a test cell 120 as illustrated for example in FIG. 14B.

[0175] At the start of the measurement process of FIG. 14A, all valves V1, V2, V3 and V4 are all opened in step 1 at time $t = 0$. Step two may begin once all valves are open, which may

be at about time $t = 0.1$ minutes. During step two, both pumps P1 and P2 may be started to pump electrolyte through the cell 120. Step two may proceed for a sufficient time and at a sufficient pump flow rate to flush out all electrolyte previously in the test cell 120 and in all tubing of the fluid delivery system 802. Once the test cell 120 is full of fresh electrolytes, the pumps may be shut off at step 3 which may be at a time of about $t = 1.9$ minutes, and the valves may be closed (step 4) at about $t = 2$ minutes.

[0176] The test cell 120 may then be discharged in a discharge process (step 5) that may begin at about time $t = 2.1$ minutes. The discharge process (step 5) may continue until a pre-determined end-point. The time interval needed to discharge the test cell to the desired end-point will be variable and is therefore represented in FIG. 14A by the variable 'X'. The end-point at which the discharging process is stopped (step 6) may be based on the rate of change of half-cell potential relative to the reference electrode. For example, if the electrolytes are known to have a negative imbalance (as determined by a reference electrode measurement as described above), the discharging end point may be the point at which the rate of change of the positive half-cell versus the reference electrode potential reaches a maximum before slowing down again. Alternatively, if the electrolytes are known to have a positive imbalance (as determined by a reference electrode measurement as described above), the discharging end-point may be the point at which the rate of change of the negative half-cell versus the reference electrode potential reaches a maximum before slowing down again. In other words, the measurement end-point may be the point at which dV/dt is a maximum (where V is potential, and t is time).

[0177] The electronic module may then determine the value of the elapsed discharge time (X), and may calculate the concentration of the indicated electrolyte. For example, the indicated electrolyte species may be Fe^{3+} if the end point is reached on the positive side, or may be Cr^{2+} if the end point is reached on the negative side. In some embodiments, the electronic module may then communicate the measured concentration value to the main flow battery control system in step 7 at about time $t=X+2.2$.

[0178] The test cell 120 may then be fully discharged to a near-zero point (step 8 at about time $t=X+2.3$ minutes) as described above with reference to the process of FIG. 12A. The discharge process may be stopped when the test cell OCV reaches a desired near-zero point (e.g., about 0.002 V in some embodiments), which may take a few seconds up to about 2 minutes, depending on several factors. The time interval for the second discharge stage may also be variable and is represented as 'Y' in FIG. 14A. Once the near-zero point is reached,

charging of the test cell 120 may begin (step 9). The test cell 120 may be charged until a desired imbalance measurement end-point is reached as discussed above. The charging time interval is represented in FIG. 14A as 'Z'. Thus, the charging process may be stopped (step 10) at time X+Y+Z+2.3 minutes. The electronic module may then calculate the degree of electrolyte imbalance (step 11) and communicate the result to the main flow battery control system.

[0179] CHRONO-POTENTIOMETRY METHODS

[0180] In alternative embodiments, the degree of cell imbalance may be monitored using chrono-potentiometry without reference electrodes. In some embodiments of this method, the electrolytes may be pumped into a test cell (e.g. a cell such as those described above with reference to FIGs. 1 – 2). In some embodiments, a volume of positive electrolyte may be pumped into a positive side of the test cell and an approximately equal volume of negative electrolyte may be pumped into a negative side of the test cell.

[0181] Once the test cell is full of electrolyte, the electrolyte flow may be shut off. The cell may be held at open circuit while the open-circuit voltage (OCV) is recorded over a period of time. As the active species ions diffuse across the separator, the OCV will decrease over time. The imbalance may then be determined from the shape of the OCV-time curve. The total time for a measurable degree of change in OCV is significantly affected by the volume of electrolytes in the test cell. Thus, in some embodiments, the test cell may be made small enough that the OCV-time curve may cover a significant voltage range (e.g., 0.9 to 0.6 V) within a short time (e.g. on the order of minutes).

[0182] At any moment, including during open circuit, the Fe³⁺ in the catholyte diffuses through the separator to the anolyte and reacts with Cr²⁺. The Cr²⁺ in the anolyte diffuses to the catholyte and reacts with Fe³⁺. In either case, the reaction is:

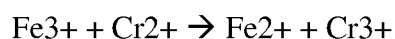

[14]

[0183] The rate of decrease in either Fe³⁺ or Cr²⁺ concentration is proportional to the sum of the two concentrations. This is described by a set of differential equations:

$$d\text{Fe}^{3+}/dt = -k (\text{Fe}^{3+} + \text{Cr}^{2+})$$

[15]

$$d\text{Cr}^{2+}/dt = -k (\text{Fe}^{3+} + \text{Cr}^{2+})$$

[16]

[0184] where 'k' is a rate constant and 't' is time. The magnitude of K may be obtained experimentally, and is mainly dependent on properties of the separator and the operating temperature. For example, K is larger for a more permeable separator.

[0185] When the value of K, and the initial concentrations of Fe³⁺ and Cr²⁺ are known, equations [7] and [8] may be solved numerically to give the concentrations of Fe³⁺ and Cr²⁺ as functions of time. The OCV of the cell may then be calculated from the Nernst equation. Practically, these values are not easily known, but the OCV of the cell at different time may be obtained from measurement. The above model may then be fitted to data of measured OCV vs. time. The initial concentrations of Fe³⁺ and Cr²⁺ and the value of K may be determined from the fitting. A graphical example 900 of such fitting is shown in FIG. 15.

[0186] FIG. 17 illustrates a graph 902 of an embodiment of an experimentally-determined relationship between cell OCV and time for various concentrations of electrolyte active materials for a particular cell arrangement. It has been found that the experimental data closely agrees with the mathematical model.

[0187] Thus, in some embodiments, this model may be used as a response for determining the extent of imbalance. For example, in some embodiments, the electrolyte concentration may be determined by measuring the time between two known voltages along the curve and matching the results to the model. For example, measuring the time between the test cell voltage reaching 0.8V and 0.6V may provide a consistently usable response because it is independent of the starting SOC. Such a relationship is shown in FIG. 15. In one embodiment, a plot of log(time) vs. imbalance raised to the 0.7th power is quite useful because it is linear, as shown in graph 904 in FIG. 16.

[0188] DENSITY MEASUREMENT EMBODIMENT

[0189] In other embodiments, electrolyte concentration, SOO and/or SOC may be monitored by measuring the density of one or both electrolytes. In some embodiments, a mixed reactant system for the fully discharged state may be: [A] 1M FeCl₂/1M CrCl₃/2M HCl, density 1.31585 g/cm³ (calculated); and [A] 2M FeCl₂/1M CrCl₃/3M HCl.

[0190] The discharged reactions are:

negative electrode: Cr²⁺ → Cr³⁺ + e⁻

[12]

positive electrode: Fe³⁺ → Fe²⁺ + e⁻

[13]

[0191] The charge reactions are the opposite of those given in Equations [2] and [3]. During charge and discharge, the valence state of Fe and Cr ions changes. To maintain electrical neutrality, various ions migrate across the separator. During charge, cations move from catholyte and anolyte, and anions move from anolyte to catholyte. During discharge, the opposite occurs. Therefore, the densities of both electrolytes change with SOO. The relationship between SOO and density may be very complex, but may be determined empirically.

[0192] Consider the change in density as a function of SOC for mixed reactant concentrations [A] and [B]. With [A], a change in SOC from 0% (fully discharged) to 100% (fully charged) yields a calculated density change of 0.000355 g/cm³ and 0.00071 g/cm³ with [B].

[0193] These changes in density may be measured with any density-measurement instrument. Such instruments are commercially available, for example from Anton-Paar, GMBH (<http://www.anton-paar.com/>) (US Office is at 10215 Timber Ridge Drive Ashland, VA 23005), using the specifications in Table 1 below.

Instrument	Repeatability	Measuring Range	Temperature Range
DMA 4100	0.00005 g/cm ³	0 to 3 g/cm ³	0 to 90 °C
DMA4500	0.00001 g/cm ³		
DMA 5000	0.000001 g/cm ³		
RXA 156	0.000002 nD	1.32 to 1.56 nD	10 to 70 °C
RXA 170	0.000004 nD	1.30 to 1.70 nD	

Table 1: Density Sensors

[0194] The examples, equations and methods for quantifying and monitoring electrolyte imbalances above are described with reference to an Fe/Cr flow battery chemistry. However the same principles and concepts may be applied to any flow battery chemistry without departing from the spirit of the invention.

[0195] Embodiments of redox flow battery cells, stack assemblies and systems described herein may be used with any electrochemical reactant combinations that include reactants dissolved in an electrolyte. One example is a stack assembly containing the vanadium reactants V(II)/V(III) or V²⁺/V³⁺ at the negative electrode (anolyte) and V(IV)/V(V) or V⁴⁺/V⁵⁺ at the positive electrode (catholyte). The anolyte and catholyte reactants in such a

system are dissolved in sulfuric acid. This type of battery is often called the all-vanadium battery because both the anolyte and catholyte contain vanadium species. Other combinations of reactants in a flow battery that may utilize the features and advantages of the systems described herein include Sn (anolyte)/Fe (catholyte), Mn (anolyte)/Fe (catholyte), V (anolyte)/Fe (catholyte), V (anolyte)/Ce (catholyte), V (anolyte)/Br₂ (catholyte), Fe (anolyte)/Br₂ (catholyte), and S (anolyte)/Br₂ (catholyte). In each of these example chemistries, the reactants are present as dissolved ionic species in the electrolytes, which permits the advantageous use of configured cascade flow battery cell and stack assembly designs in which cells have different physical, chemical or electrochemical properties along the cascade flow path (e.g. cell size, type of membrane or separator, type and amount of catalyst, etc.). A further example of a workable redox flow battery chemistry and system is provided in U.S. Pat. No. 6,475,661, the entire contents of which are incorporated herein by reference. Many of the embodiments herein may be applied to so-called "hybrid" flow batteries (such as a zinc/bromine battery system) which use only a single flowing electrolyte.

[0196] FIG. 18 is a schematic block diagram illustrating an example of a hardware implementation for an electronic module 198 for monitoring and controlling a test cell 120. In this example, the electronic module 198 may be implemented with a bus architecture, represented generally by the bus 1002. The bus 1002 may include any number of interconnecting buses and bridges depending on the specific application of the electronic module 198 and the overall design constraints. The bus 1002 links together various circuits including one or more processors, represented generally by the processor 1004, and computer-readable media, represented generally by the computer-readable medium 1006. The bus 1002 may also link various other circuits such as timing sources, peripherals, sensors, and power management circuits, which are well known in the art, and therefore, will not be described any further. A bus interface 1008 provides an interface between the bus 1002 and the test cell 120. Depending upon the nature of the apparatus, a user interface 1012 (e.g., keypad, display, speaker, microphone, joystick) may also be provided. The processor 1004 is responsible for managing the bus 1002 and general processing, including the execution of software or instructions 1014 stored on the computer-readable medium 1006. The software, when executed by the processor 1004, causes the electronic module 198 to perform the various functions described above for any particular apparatus. The computer-readable medium 1006 may also be used for storing data that is manipulated by the processor 1004 when executing software or instructions 1014. In some embodiments, analog electronics 1016

may also be joined to the bus 1002 by an analog-to-digital converter 1018 (and in some embodiments a digital-to-analog converter). Analog electronics 1016 may be provided to perform various analog functions such as voltage regulation, electric current measurement, current regulation or other functions.

[0197] FIG. 19 illustrates a method 1100 of determining a degree of electrolyte imbalance in a reduction-oxidation (redox) flow battery system. In method 1100, a monitoring system may introduce a first liquid electrolyte into a first chamber of a test cell in block 1102 and introduce a second liquid electrolyte into a second chamber of the test cell in block 1104. The monitoring system may measure a voltage of the test cell in block 1106. The monitoring system may measure an elapsed time from the test cell reaching a first voltage until voltage test end-point is reached in block 1108. In block 1110, a monitoring system may determine a concentration of at least one reactant in the first and second liquid electrolytes based on the elapsed time.

[0198] The foregoing description of the various embodiments is provided to enable any person skilled in the art to make or use the present invention. Various modifications to these embodiments will be readily apparent to those skilled in the art, and the generic principles defined herein may be applied to other embodiments without departing from the spirit or scope of the invention. Thus, the present invention is not intended to be limited to the embodiments shown herein, and instead the claims should be accorded the widest scope consistent with the principles and novel features disclosed herein.

[0199] In particular, materials and manufacturing techniques may be employed as within the level of those with skill in the relevant art. Furthermore, reference to a singular item, includes the possibility that there are plural of the same items present. More specifically, as used herein and in the appended claims, the singular forms "a," "and," "said," and "the" include plural referents unless the context clearly dictates otherwise. As used herein, unless explicitly stated otherwise, the term "or" is inclusive of all presented alternatives, and means essentially the same as the commonly used phrase "and/or." Thus, for example the phrase "A or B may be blue" may mean any of the following: A alone is blue, B alone is blue, both A and B are blue, and A, B and C are blue. It is further noted that the claims may be drafted to exclude any optional element. As such, this statement is intended to serve as antecedent basis for use of such exclusive terminology as "solely," "only" and the like in connection with the recitation of claim elements, or use of a "negative" limitation. Unless defined otherwise

herein, all technical and scientific terms used herein have the same meaning as commonly understood by one of ordinary skill in the art to which this invention belongs.

CLAIMS

What is claimed is:

1. A method of determining a degree of electrolyte imbalance in a reduction-oxidation (redox) flow battery system, the method comprising:
 - introducing a first liquid electrolyte into a first chamber of a test cell;
 - introducing a second liquid electrolyte into a second chamber of the test cell;
 - measuring a voltage of the test cell;
 - measuring an elapsed time from the test cell reaching a first voltage until voltage test end-point is reached; and
 - determining a concentration of at least one reactant in the first and second liquid electrolytes based on the elapsed time.
2. The method of claim 1, further comprising applying a charging current to the test cell, and wherein the first voltage is substantially near zero.
3. The method of claim 2, further comprising measuring an open circuit voltage of the test cell by pulsing the charging current.
4. The method of claim 2, wherein the test end-point comprises a maximum rate of change of the measured voltage with respect to time.
5. The method of claim 1, wherein the first liquid electrolyte is a catholyte and the second liquid electrolyte is an anolyte.
6. The method of claim 5, wherein a quantity of the first electrolyte introduced into the test cell is equal to a quantity of the second electrolyte introduced into the test cell.
7. The method of claim 5, wherein discharging the test cell further comprises mixing an anolyte and a catholyte that comprise the first and first and second liquid electrolytes prior to introduction into the test cell.
8. The method of claim 5, further comprising discharging the test cell after introducing electrolyte into the chambers of the test cell.

9. The method of claim 8, further comprising discharging the test cell by short circuiting a pair of electrodes of the test cell.
10. The method of claim 8, wherein measuring the voltage of the test cell comprises measuring an open-circuit voltage.
11. The method of claim 8, further comprising discharging the test cell by applying a discharge current.
12. The method of claim 11, further comprising measuring an open-circuit voltage of the test cell by pulsing the discharge current.
13. The method of claim 12 further comprising measuring the open circuit voltage during a time interval when the discharge current is not applied.
14. The method of claim 1, wherein the first liquid electrolyte and the second liquid electrolyte are the same liquid electrolyte.
15. The method of claim 14, wherein the first and second electrolytes comprise a selected one of a catholyte and an anolyte, the method further comprising measuring the voltage of the test cell by using open circuit voltage without a reference electrode.
16. The method of claim 14, wherein the liquid electrolyte is one of a catholyte and an anolyte.
17. The method of claim 16, further comprising determining a concentration of a reactant that is generated when the test cell is charged.
18. The method of claim 1, further comprising measuring an electric potential of at least one of the first liquid electrolyte and the second liquid electrolyte with a reference electrode.
19. The method of claim 18, further comprising determining a concentration of a species that is generated when the test cell is charged.

20. The method of claim 1, further comprising determining a degree of imbalance in species that are generated during charging in the first and second liquid electrolytes.
21. The method of claim 1, further comprising determining the degree of imbalance based on empirically obtained data as a function of elapsed time.
22. The method of claim 1, further comprising determining the degree of imbalance based on empirically obtained data as a function of an amount of charge passed through the test cell.
23. The method of claim 1, further comprising a through-flow fluid delivery arrangement.
24. The method of claim 1, further comprising a reciprocating flow fluid delivery arrangement.
25. An electronic controller, comprising:
a processor; and
a non-transitory computer-readable medium coupled to the processor and containing processor-executable instructions to perform operations comprising:
introducing a first liquid electrolyte into a first chamber of a test cell,
introducing a second liquid electrolyte into a second chamber of the test cell,
measuring a voltage of the test cell,
measuring an elapsed time from the test cell reaching a first voltage until voltage test end-point is reached, and
determining a concentration of at least one reactant in the first and second liquid electrolytes based on the elapsed time.
26. A reduction-oxidation (redox) flow battery system, comprising:
a redox flow battery;
a test cell fluidically coupled to the redox flow battery; and
an electronic controller, comprising:
a processor; and
a non-transitory computer-readable medium coupled to the processor and containing processor-executable instructions to perform operations comprising:

introducing a first liquid electrolyte into a first chamber of a test cell,
introducing a second liquid electrolyte into a second chamber of the
test cell,
measuring a voltage of the test cell,
measuring an elapsed time from the test cell reaching a first voltage
until voltage test end-point is reached, and
determining a concentration of at least one reactant in the first and
second liquid electrolytes based on the elapsed time.

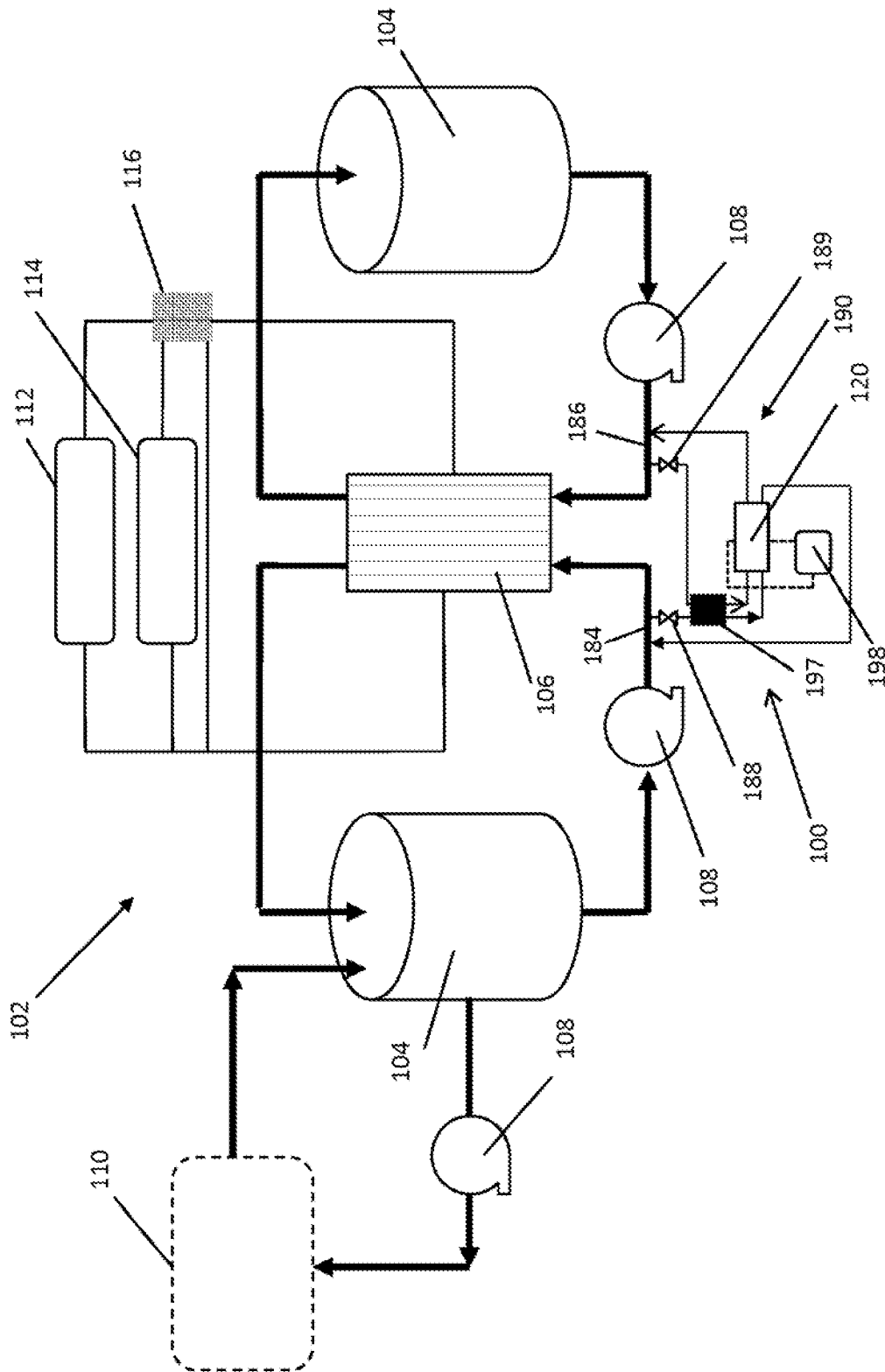

FIG. 1

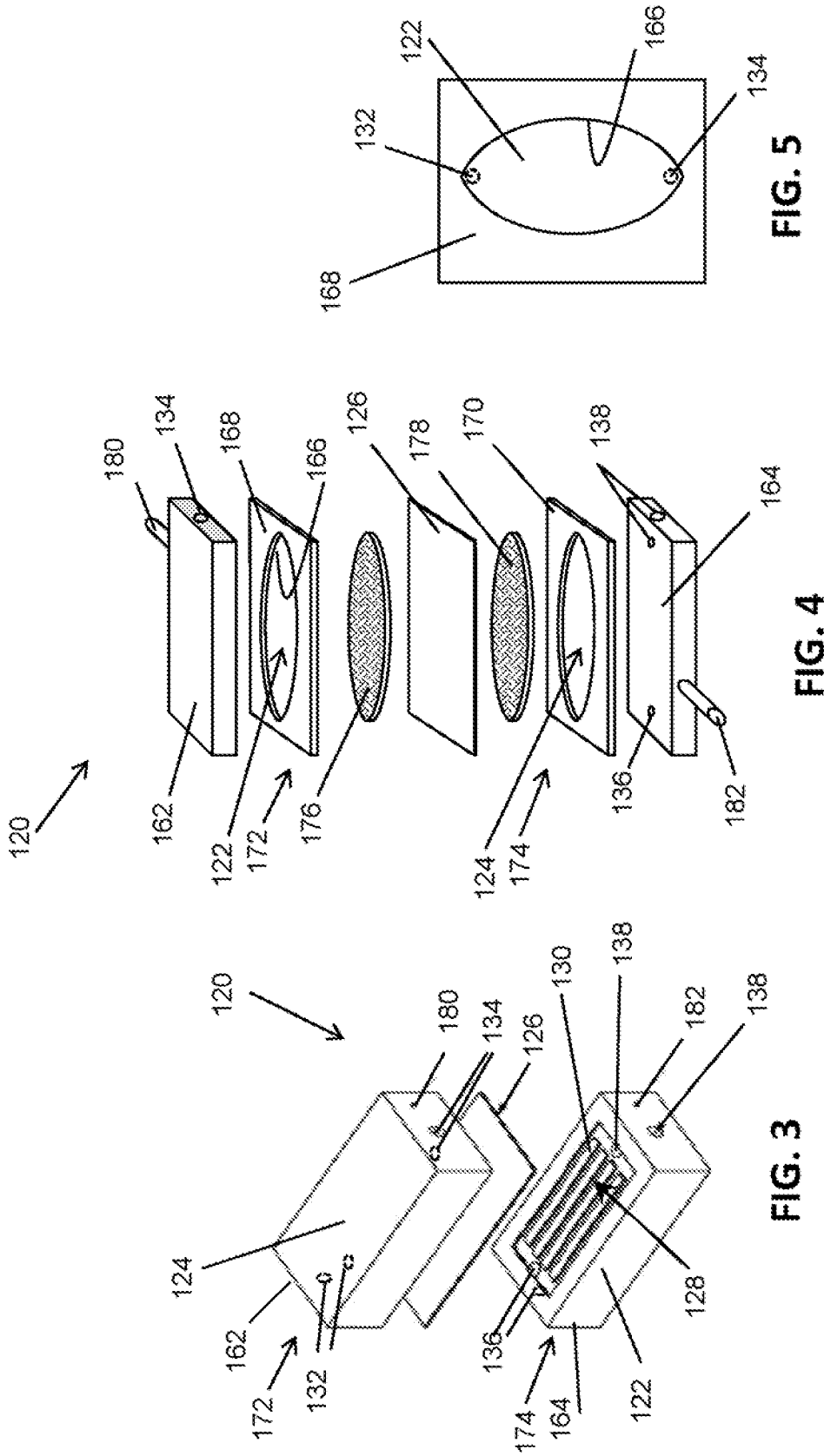

FIG. 5

FIG. 4

FIG. 3

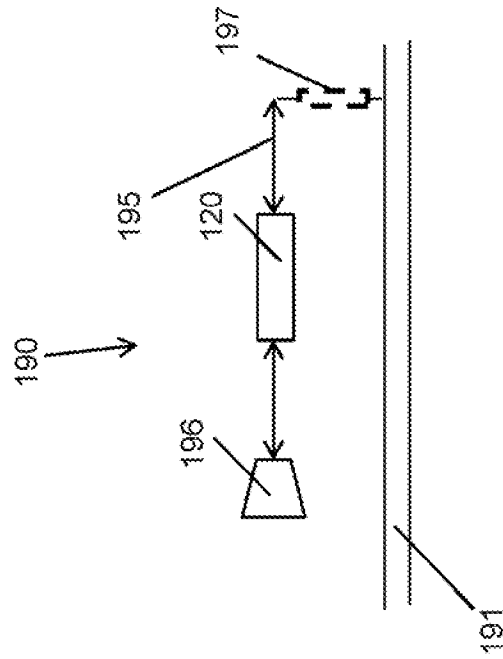

FIG. 6B

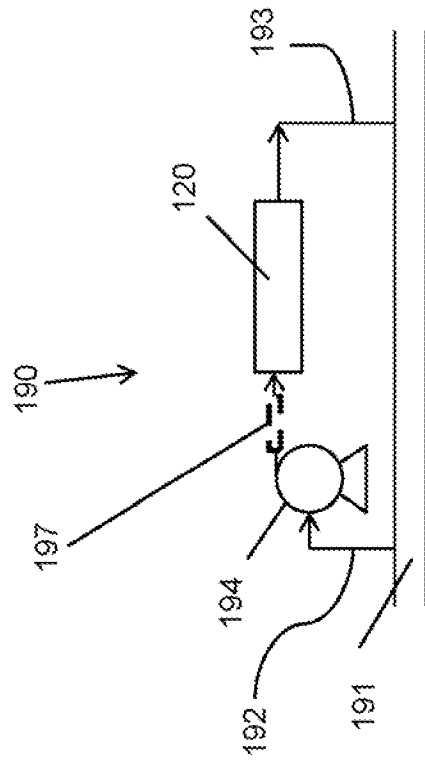

FIG. 6A

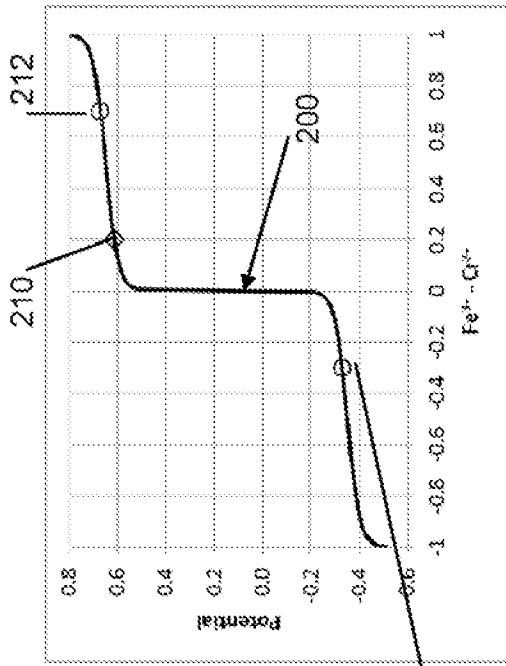

FIG. 7B

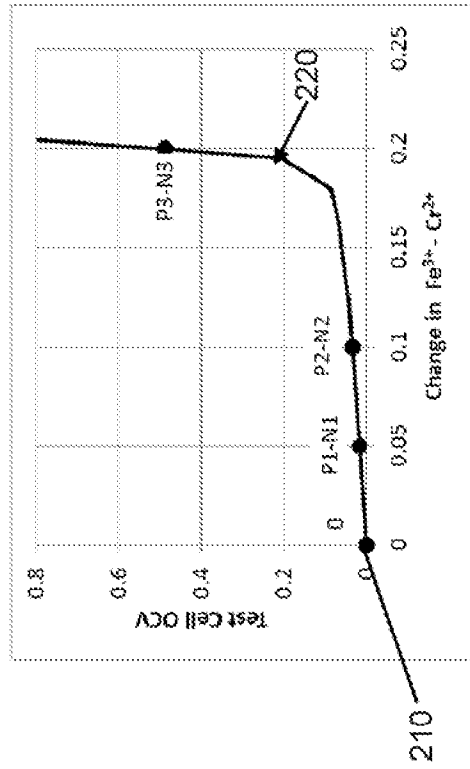

FIG. 7D

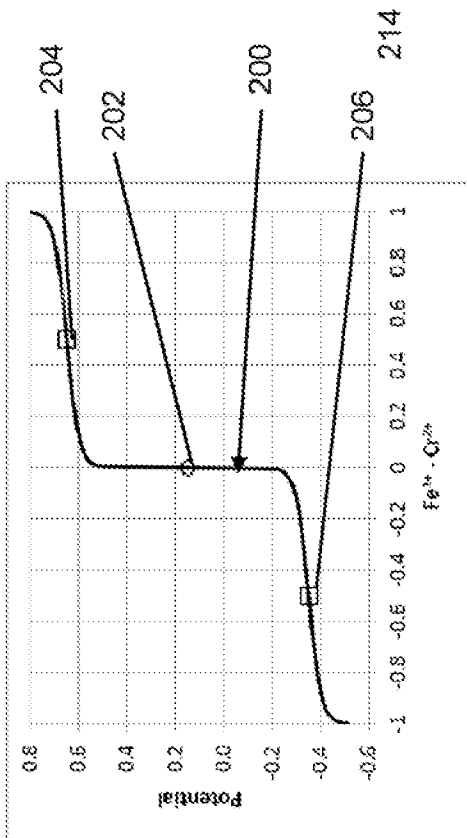

FIG. 7A

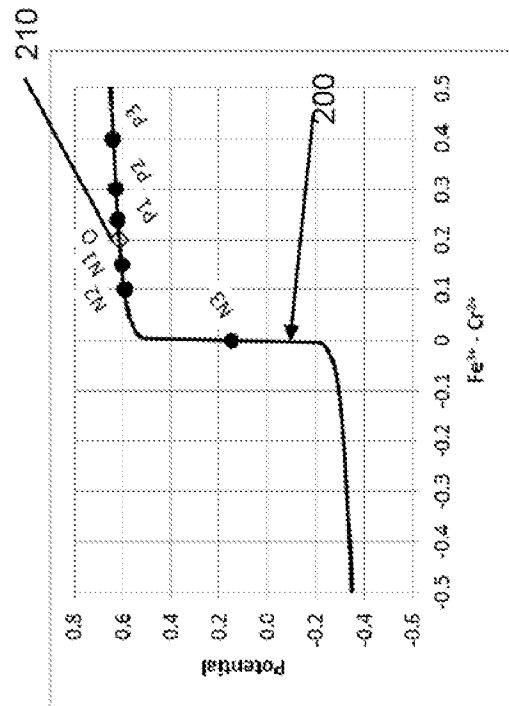

FIG. 7C

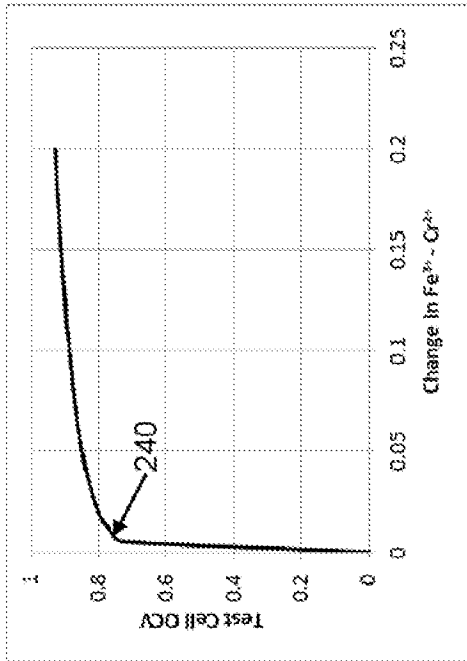

FIG. 7F

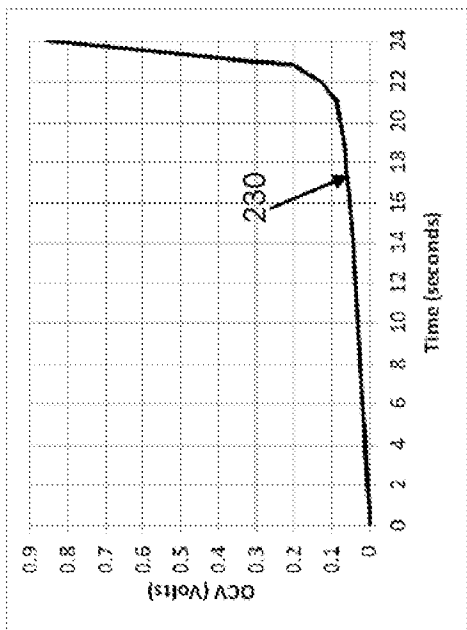

FIG. 7E

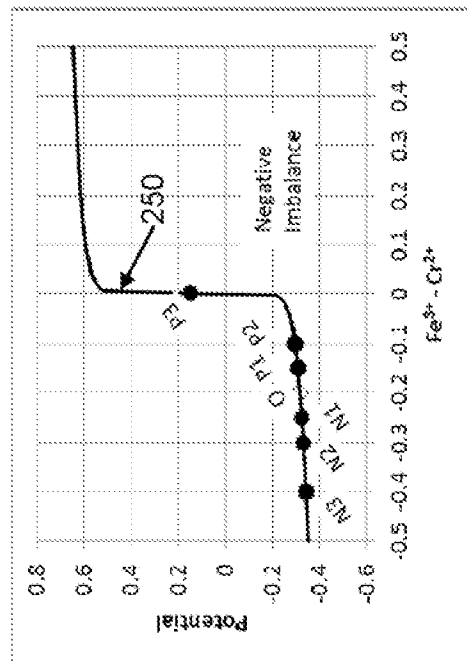

FIG. 7G

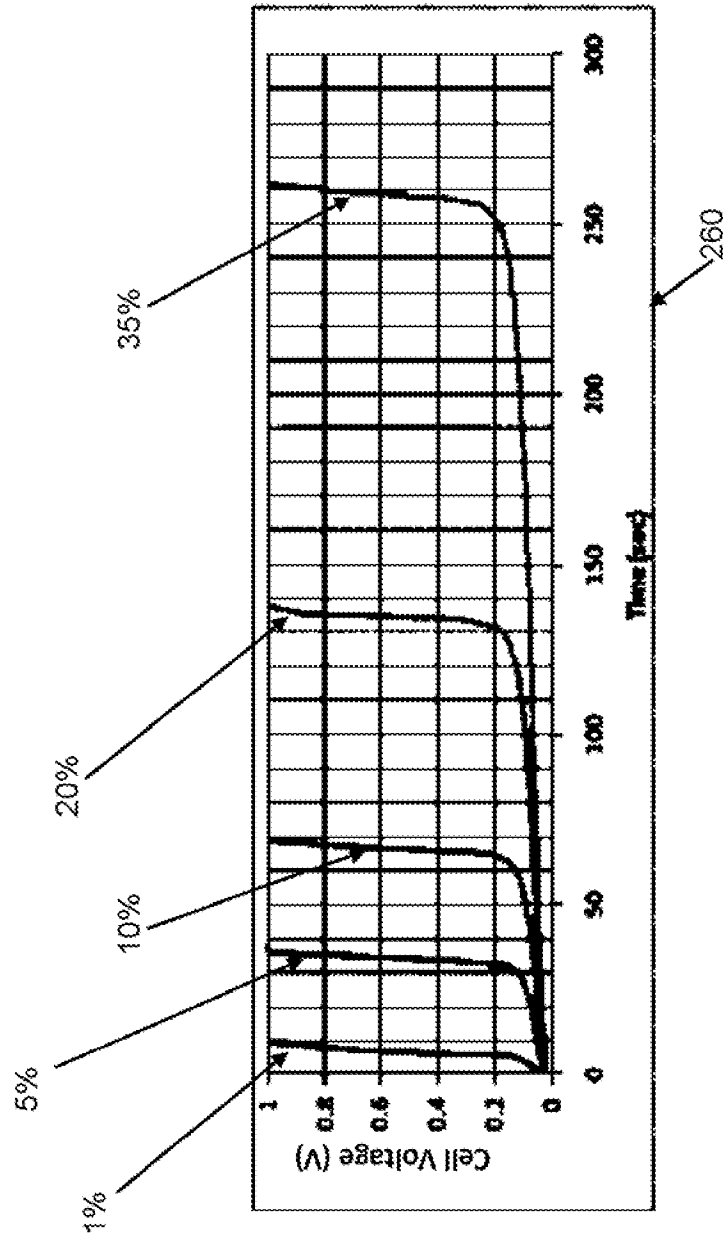

FIG. 8

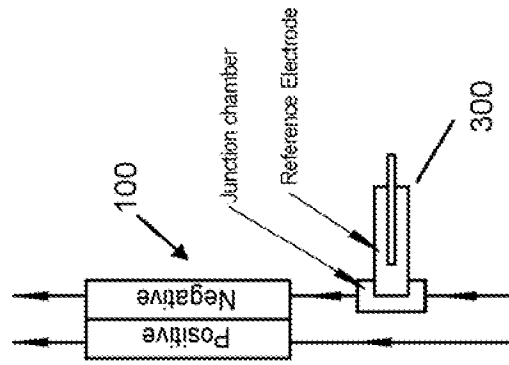

FIG. 9C

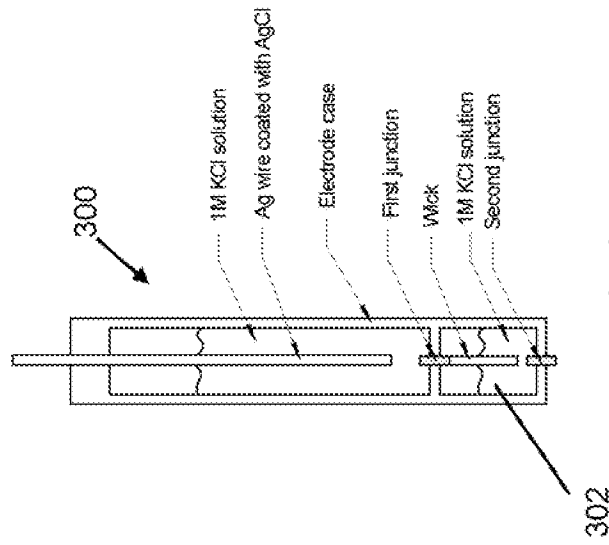

FIG. 9B

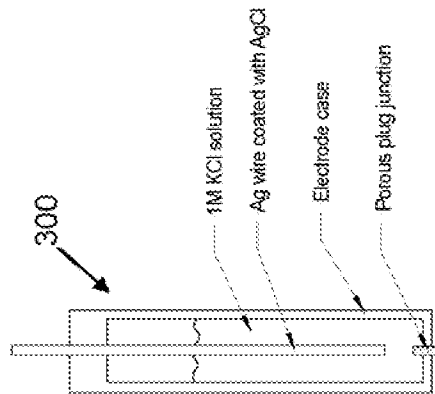

FIG. 9A

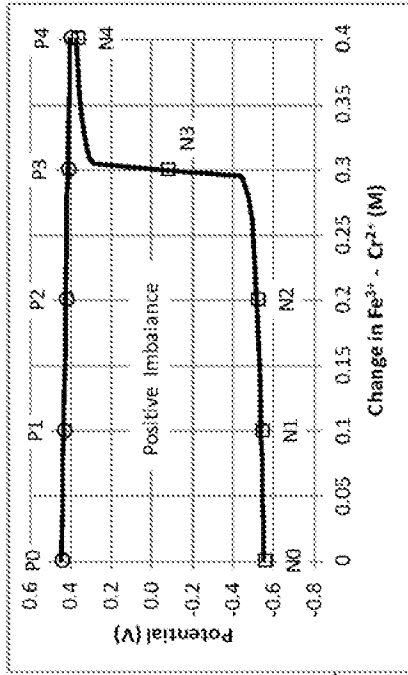

FIG. 10A

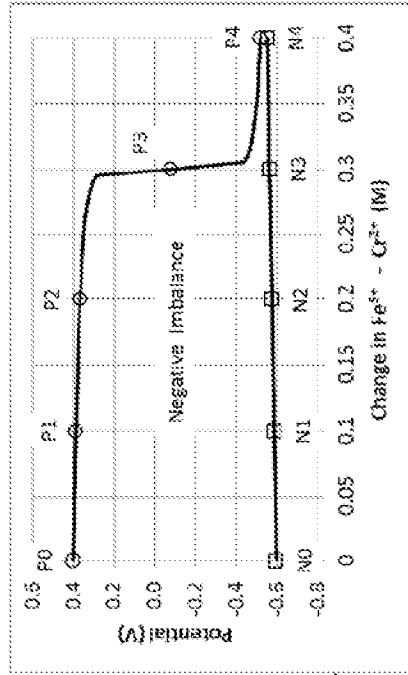

FIG. 10B

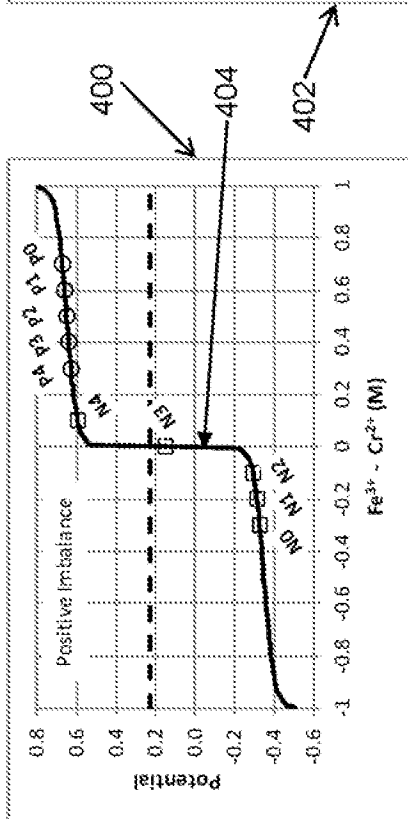

FIG. 10C

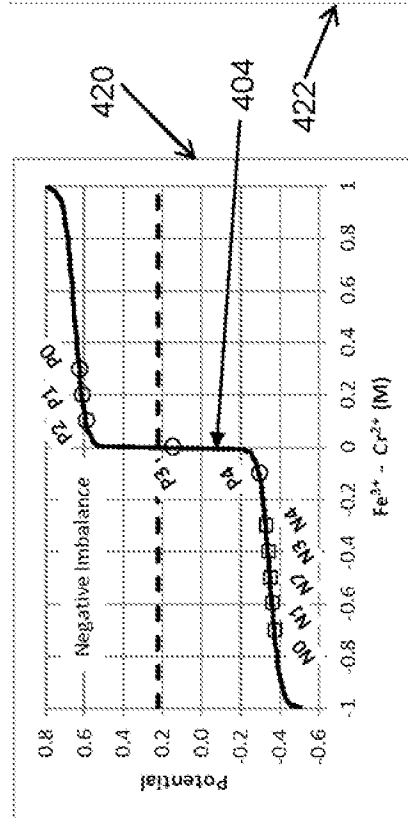

FIG. 10D

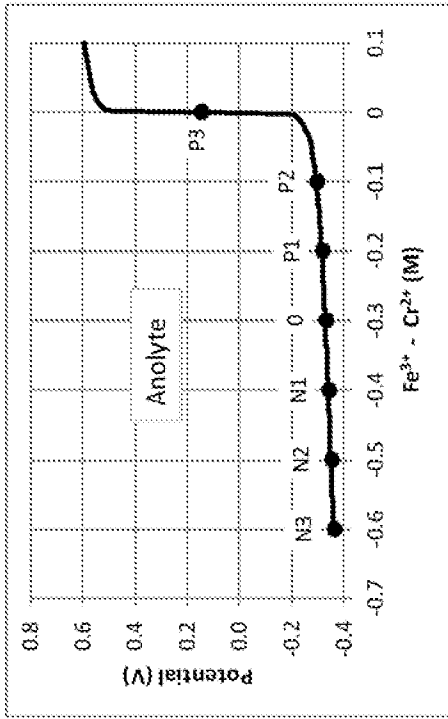

FIG. 11B

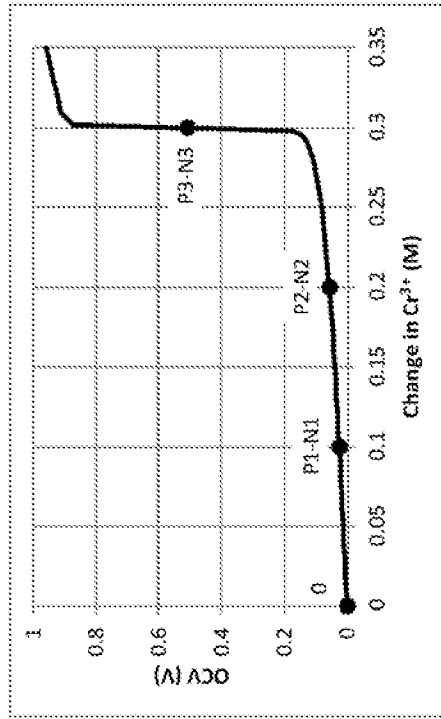

FIG. 11D

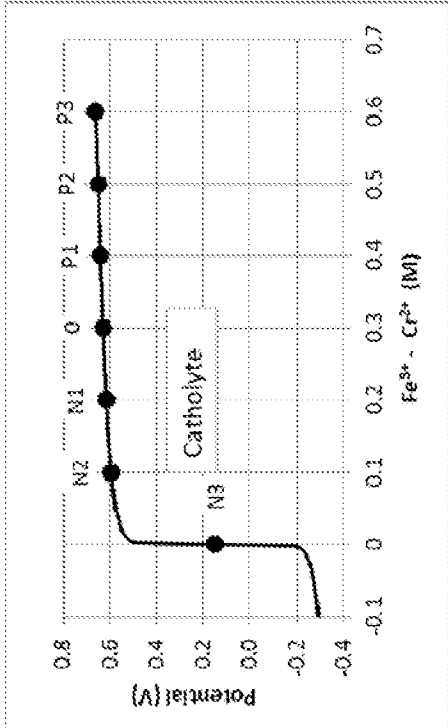

FIG. 11A

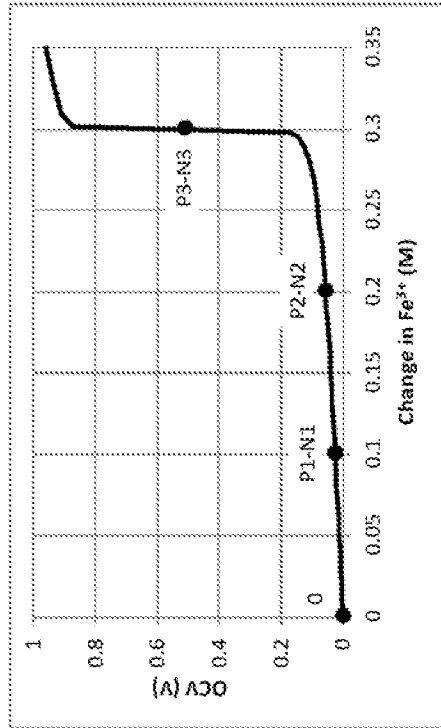

FIG. 11C

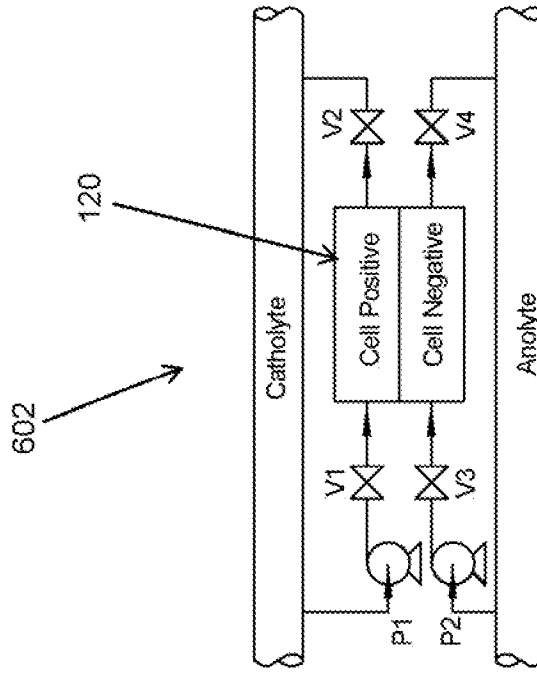

FIG. 12B

Step	Time (minutes)	Action
1	0	Open all valves
2	0.1	Turn on both pumps
3	1.9	Turn off both pumps
4	2.0	Close all valves
5	2.1	Start discharging
6	X+2.1	Stop discharging, Start charging
7	X+Y+2.1	Stop charging
8	X+Y+2.2	Electronic module calculates imbalance from the end point.

FIG. 12A

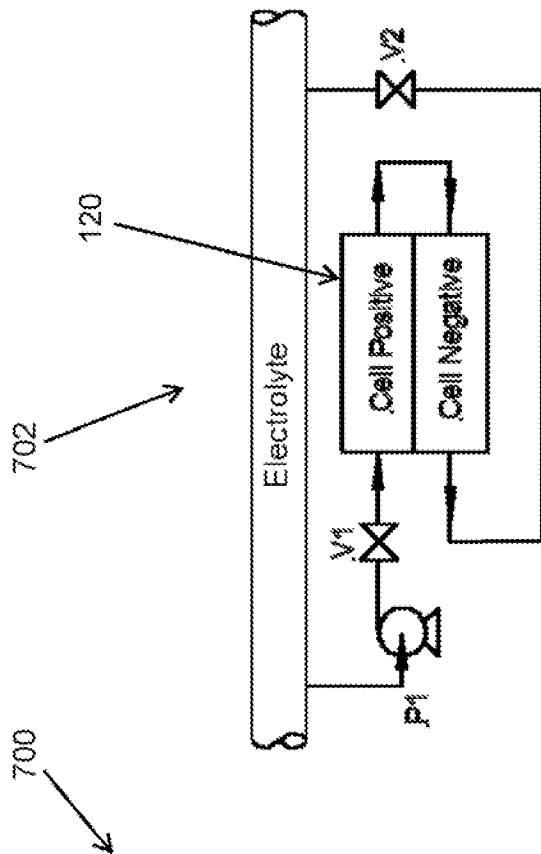

FIG. 13B

Step	Time (minutes)	Action
1	0	Open both valves
2	0.1	Turn on pump
3	1.9	Turn off pump
4	2.0	Close both valves
5	2.1	Start charging
6	X+2.1	Stop charging
7	X+2.2	Electronic module determines the end point and calculates charged reactant concentration in the electrolyte

FIG. 13A

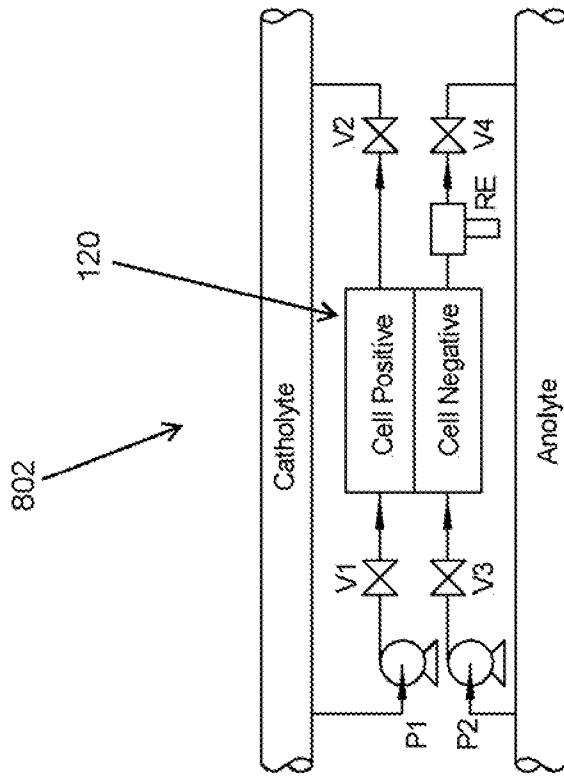

FIG. 14B

Step	Time (minutes)	Action
1	0	Open all valves
2	0.1	Turn on both pumps
3	1.9	Turn off both pumps
4	2.0	Close all valves
5	2.1	Start discharging
6	X+2.1	Stop discharging
7	X+2.2	Electronic module determines the end point, calculates concentration of Fe^{3+} (if end point is reached on the positive side) or Cr^{2+} (if end point is reached on the negative side)
8	X+2.3	Start discharging
9	X+Y+2.3	Stop discharging, Start charging
10	X+Y+Z+2.3	Stop charging
11	X+Y+Z+2.4	Electronic module calculates imbalance and the other concentration,

FIG. 14A

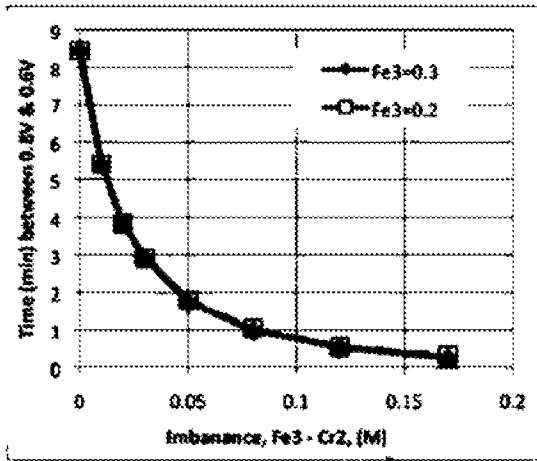

FIG. 15

900

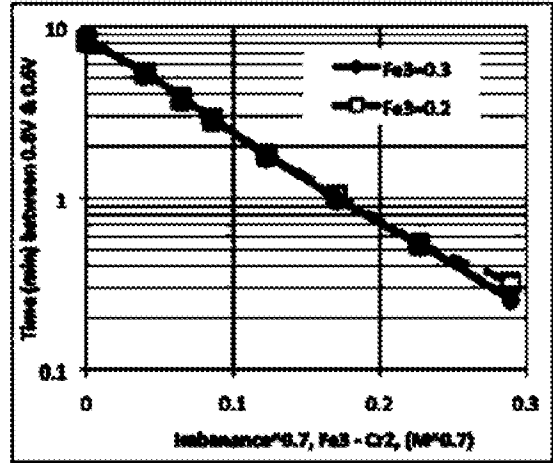

FIG. 16

904

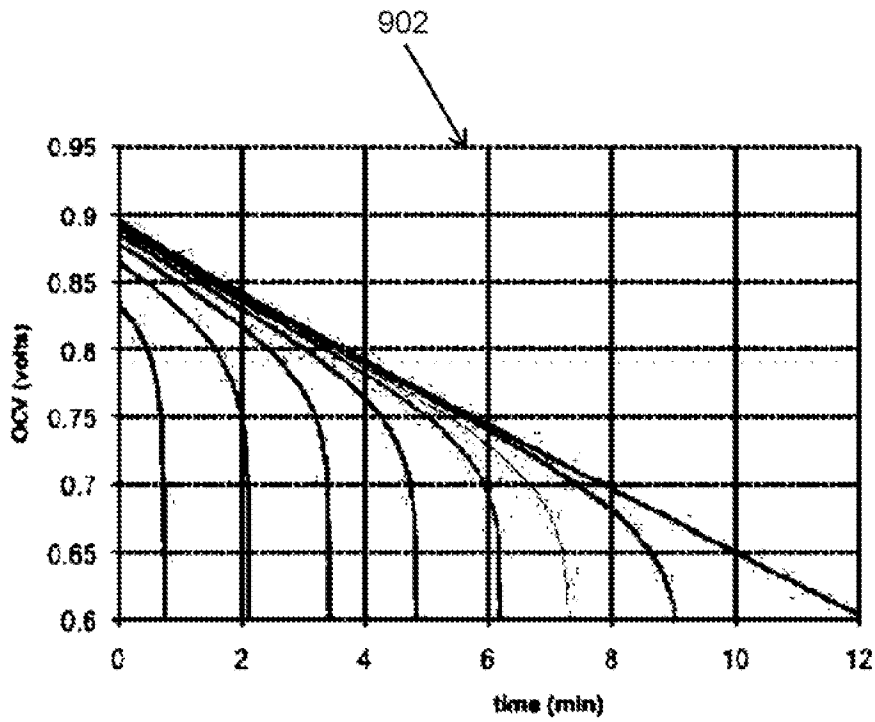

FIG. 17

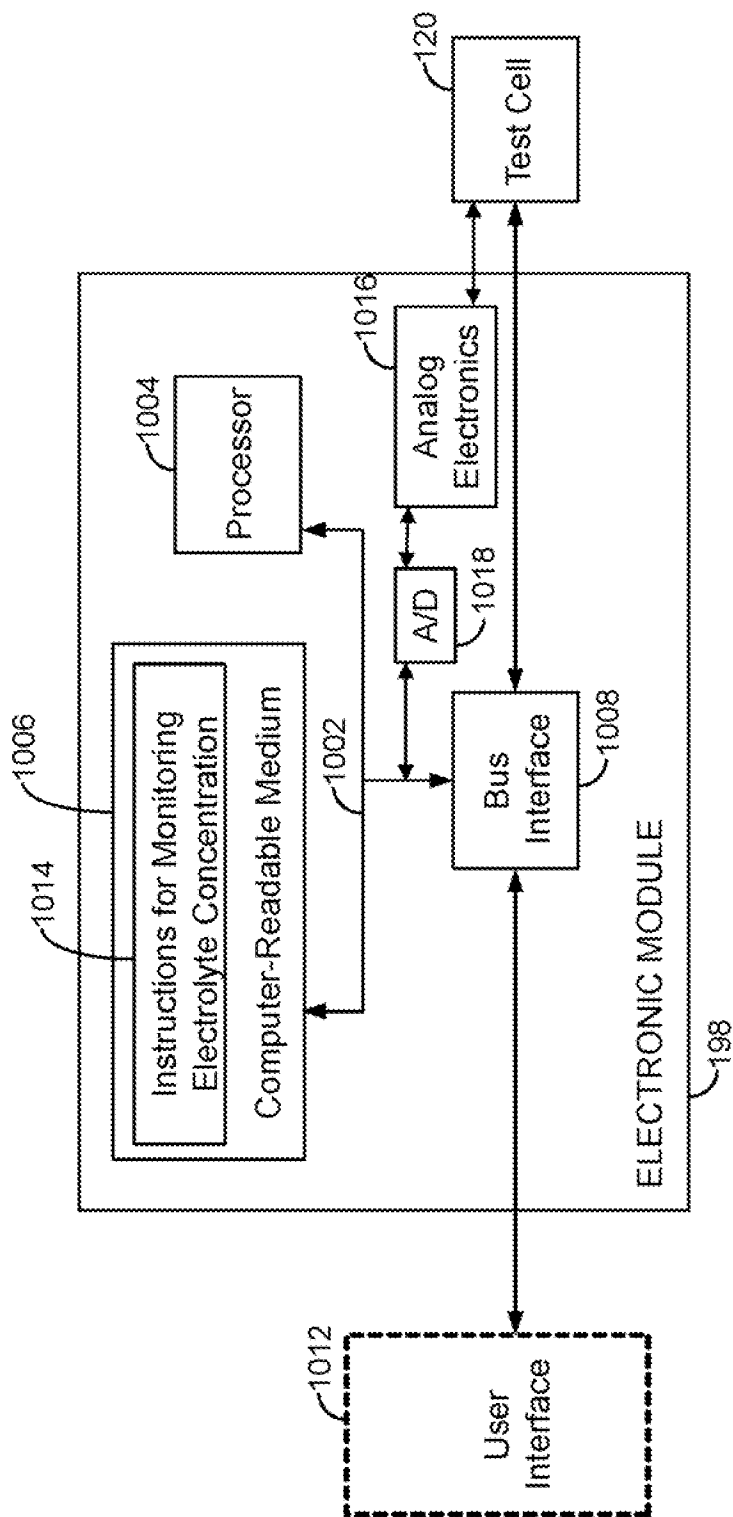

FIG. 18

16/16

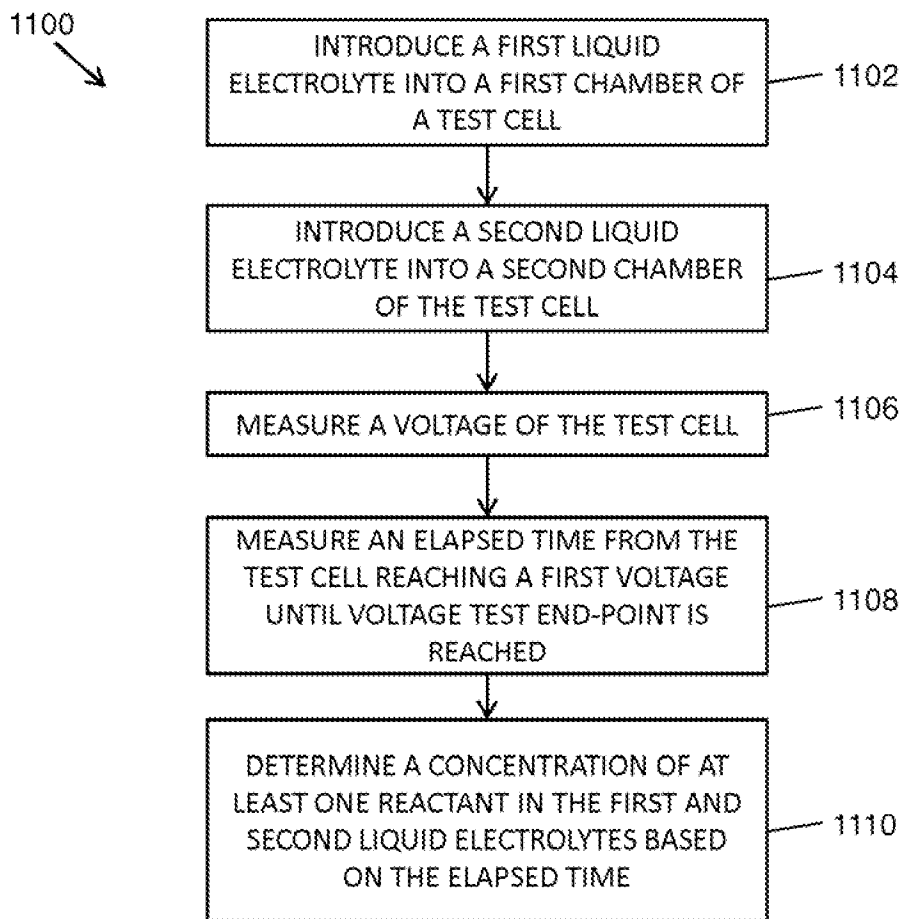

FIG. 19