

(19) World Intellectual Property Organization
International Bureau



(43) International Publication Date
18 October 2001 (18.10.2001)

PCT

(10) International Publication Number
WO 01/77480 A2

- (51) International Patent Classification⁷: E21B
- (21) International Application Number: PCT/GB01/01567
- (22) International Filing Date: 5 April 2001 (05.04.2001)
- (25) Filing Language: English
- (26) Publication Language: English
- (30) Priority Data:
09/547,068 11 April 2000 (11.04.2000) US
- (71) Applicant (for all designated States except US): WEATHERFORD/LAMB, INC. [US/US]; Suite 600, 515 Post Oak Boulevard, Houston, TX 77027 (US).
- (71) Applicant (for GB only): HARDING, Richard, Patrick [GB/GB]; Marks & Clerk, 4220 Nash Court, Oxford Business Park South, Oxford, Oxfordshire OX4 2RU (GB).
- (71) Applicants and
(72) Inventors: BRUNNERT, David, J. [US/US]; 7915 Clarion Way, Houston, TX 77040 (US). CARTER, Thurman, B. [US/US]; 2901 Roseheath Lane, Houston, TX 77073 (US). INGRAM, Gary, D. [US/US]; 6327 Bridlewood Drive, Richmond, TX 77469 (US). TEALE, David [US/US]; 6311 Rippling Hollow, Spring, TX 77379 (US).
- (72) Inventor; and
(75) Inventor/Applicant (for US only): HAUGEN, David, Michael [US/US]; 408 N. Iowa Avenue, League City, TX 77573 (US).
- (74) Agent: HARDING, Richard, Patrick; Marks & Clerk, 4220 Nash Court, Oxford Business Park South, Oxford, Oxfordshire OX4 2RU (GB).
- (81) Designated States (national): AE, AG, AL, AM, AT, AU, AZ, BA, BB, BG, BR, BY, BZ, CA, CH, CN, CR, CU, CZ, DE, DK, DM, DZ, EE, ES, FI, GB, GD, GE, GH, GM, HR,

[Continued on next page]

(54) Title: APPARATUS TO ACTUATE DOWNHOLE TOOL

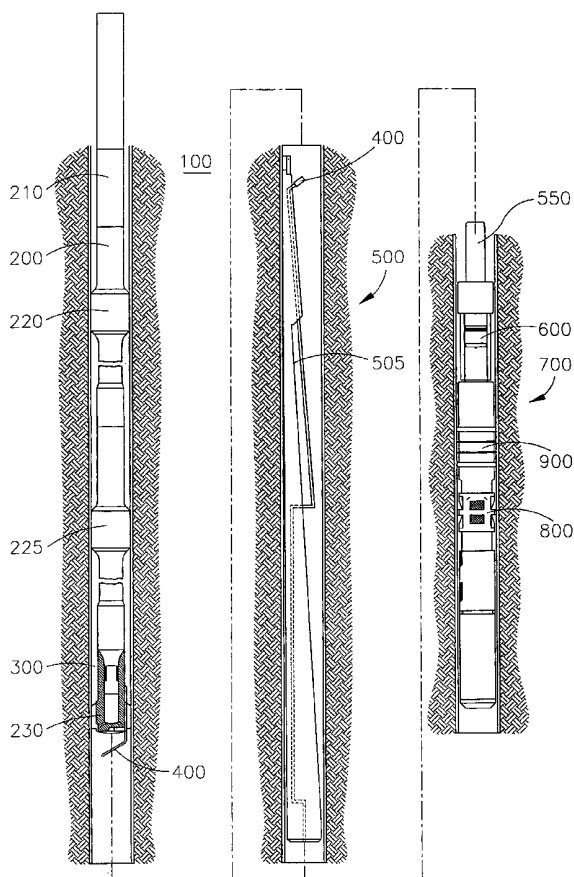

(57) Abstract: The invention provides an apparatus (300, 400) for actuating a downhole tool (700) by utilizing a pressure differential created by fluid flowing through a conduit (315). The conduit is in communication with a pressure sensing line (400) that is selectively exposable to areas of the conduit (316, 317) having different pressures. By exposing the pressure sensing line to a portion of the conduit having a predetermined pressure therein, the pressure sensing line causes actuation of a hydraulic tool therebelow.



WO 01/77480 A2



HU, ID, IL, IN, IS, JP, KE, KG, KP, KR, KZ, LC, LK, LR, LS, LT, LU, LV, MA, MD, MG, MK, MN, MW, MX, MZ, NO, NZ, PL, PT, RO, RU, SD, SE, SG, SI, SK, SL, TJ, TM, TR, TT, TZ, UA, UG, US, UZ, VN, YU, ZA, ZW.

(84) Designated States (regional): ARIPO patent (GH, GM, KE, LS, MW, MZ, SD, SL, SZ, TZ, UG, ZW), Eurasian patent (AM, AZ, BY, KG, KZ, MD, RU, TJ, TM), European patent (AT, BE, CH, CY, DE, DK, ES, FI, FR, GB, GR, IE, IT, LU, MC, NL, PT, SE, TR), OAPI patent (BF, BJ, CF, CG, CI, CM, GA, GN, GW, ML, MR, NE, SN, TD, TG).

Published:

— *without international search report and to be republished upon receipt of that report*

For two-letter codes and other abbreviations, refer to the "Guidance Notes on Codes and Abbreviations" appearing at the beginning of each regular issue of the PCT Gazette.

APPARATUS TO ACTUATE DOWNHOLE TOOL

This invention relates generally to methods and apparatus for actuating a tool in a borehole. More particularly, the invention relates to orienting or positioning a tool in a borehole and, once properly oriented, setting the tool in a fixed position. Still more particularly, the invention relates to an actuation apparatus that uses a pressure differential in a conduit carrying a fluid flow to actuate a downhole tool.

Hydraulically-actuated tools such as packers and anchor assemblies have long been used in the drilling industry. A tool often used in conjunction with anchors or packers is a whipstock. A whipstock includes an inclined face and is typically used to direct a drill bit or cutter in a direction that deviates from the existing borehole. The combination whipstock and anchor (or packer) is frequently termed a sidetrack system. Sidetrack systems have traditionally been used to mill a window in the well casing, and thereafter to drill through the casing window and form the lateral borehole.

Originally, such a sidetrack operation required two trips of the drill string. The first trip was used to run and set the anchor or packing device at the appropriate elevation in the borehole. With the anchor or packer in place, the drill string was then removed from the well and a survey was made to determine the orientation of a key on the upper end of the anchor-packer. With that orientation known, the whipstock was then configured on the surface so that when the whipstock engaged the anchor-packer in the borehole, it would be properly oriented. So configured, the whipstock, along with an attached cutter, was then lowered in the borehole on the drill string and secured to the anchor-packer. Once connected to and supported by the packer, the whipstock directed the cutter so that a window would be milled in the casing of the borehole at the desired elevation and in the preselected orientation. This two-trip operation for setting the anchor-packer and then lowering the whipstock and cutter is time-consuming and expensive, particularly in very deep wells.

30

To eliminate the expense associated with two trips of the drill string, an improved sidetrack system was developed which required only a single trip. Such a system includes a whipstock having an anchor-packer connected at its lower end, and a

cutter assembly at its upper end connected by a shearable connection. Using such a system, the whipstock is oriented by first lowering the apparatus into the cased borehole on a drill string. A wireline survey instrument is then run through the drill string to check for the proper orientation of the suspended whipstock. After the whipstock is properly oriented in the borehole, and the anchor-packer set, the drill string is then lowered causing the cutter assembly to become disconnected from the whipstock. As the cutter is lowered further, the inclined surface of the whipstock cams the rotating cutter against the well casing, causing the cutter to mill a window in the casing at the predetermined orientation and elevation.

10

To be contrasted with wireline devices, there exist today a variety of systems that are capable of collecting and transmitting data from a position near the drill bit while drilling is in progress. Such measuring-while-drilling ("MWD") systems are typically housed in a drill collar at the lower end of the drill string. In addition to being used to detect formation data, such as resistivity, porosity, and gamma radiation, all of which are useful to the driller in determining the type of formation that surrounds the borehole, MWD tools are also useful in surveying applications, such as, for example, in determining the direction and inclination of the drill bit. Present MWD systems typically employ sensors or transducers which, while drilling is in progress, continuously or intermittently gather the desired drilling parameters and formation data and transmit the information to surface detectors by some form of telemetry, most typically a mud pulse system. The mud pulse system creates acoustic signals in the drilling mud that is circulated through the drill string during drilling operations. The information acquired by the MWD sensors is transmitted by suitably timing the formation of pressure pulses in the mud stream. The pressure pulses are received at the surface by pressure transducers which convert the acoustic signals to electrical pulses which are then decoded by a computer.

20

MWD tools presently exist that can detect the orientation of the drill string without the difficulties and drawbacks described above that are inherent with the use of wireline sensors. However, known MWD tools typically require drilling fluid flow rates of approximately 250 gallons per minute to start the tool, and 350 to 400 gallons per minute to gather the necessary data and transmit it to the surface via the mud pulse

30

telemetry system. The conventional bypass valves used in present-day sidetrack systems for circulating drilling fluid and transporting a wireline sensor to the whipstock tend to close, and thereby actuate the anchor-packer, at flow rates of approximately 100 gallons per minute, or even less. Thus, while it might be desirable to combine MWD sensors in a sidetrack system, if drilling mud was circulated through the drill string at the rate necessary for the MWD tool to detect and communicate to the driller the orientation of the whipstock, the bypass valve might close and the anchor-packer would be set prematurely, before the whipstock was properly oriented.

10 An improved apparatus for setting a hydraulically actuatable downhole tool in a borehole is disclosed in U.S. Patent No. 5,443,129, incorporated herein by reference in its entirety. This apparatus utilizes a bypass valve located in the run-in string below the MWD device and above the cutter. The valve is in an open position while the MWD device is operating thereby diverting fluid flow and pressure from the tubular to the annulus without creating a pressure sufficient to actuate a downhole tool. Upon completion of operation of the MWD device, the bypass valve is remotely closed. Thereafter, selectively operable ports in the cutter are opened and the tubular therebelow is pressurized to a point necessary to actuate the tool. While this apparatus allows operation of a MWD device without the inadvertent actuation of a downhole tool, the bypass valve is complex requiring many moving parts and prevents the continuous flow of fluid through the cutter. Additionally, fluid borne sediment tends to settle and collect in the cutter, creating a potential for operational problems.

25 There is a need therefore, for a single trip sidetrack apparatus permitting a continuous flow of well fluid therethrough while allowing the actuation of a hydraulically actuated tool at a predetermined position in the borehole. There is a further need therefore, for a single trip sidetrack apparatus that includes a MWD device that can be continuously operated. There is a further need for a single trip sidetrack apparatus that does not depend on a valve to prevent inadvertent actuation of a downhole tool. There is yet a further need for an actuation apparatus that allows fluid to flow therethrough before and during actuation of a downhole tool.

In accordance with one aspect of the present invention there is provided an apparatus for actuating a downhole tool comprising a first conduit for flowing fluid therethrough, a pressure sensing line in communication with the first conduit, the pressure sensing line sensing pressure in the first conduit and communicating a
5 predetermined pressure to the downhole tool to actuate the downhole tool.

Further aspects and preferred features are set out in claims 2 *et seq.*

Preferred embodiments of the invention provide an apparatus for actuating a
10 downhole tool by utilizing a pressure differential created by fluid flowing through a conduit. The conduit is in communication with a pressure sensing line that is selectively exposable to areas of the conduit having different pressures. By exposing the pressure sensing line to a portion of the conduit having a predetermined pressure therein, the pressure sensing line causes actuation of a hydraulic tool therebelow.

15

In one embodiment of the invention, fluid flowing through the conduit is utilized to operate a MWD. Thereafter, the pressure line is exposed to a predetermined pressure and the hydraulic tool is actuated. In one embodiment of the invention, the pressure in a given area of the conduit is increased due to a restriction therein. At a predetermined
20 time, the pressure line is exposed to the given area and pressure therein actuates the hydraulic tool. Preferred embodiments of the invention include a running assembly on a drill string, the assembly including an MWD, a pressure changing and sensing mechanism and a cutter.

25 Some preferred embodiments of the invention will now be described by way of example only and with reference to the accompanying drawings, in which:

Figure 1 is an elevation view, partly in cross-section, of a borehole with a sidetrack system in accordance with the present invention suspended therein;

30

Figure 2A is a section view showing an upper actuation apparatus in an un-actuated state;

Figure 2B is a section view showing the upper actuation apparatus in an actuated state;

Figure 3A is a section view showing a lower actuation apparatus in an unactuated state;

Figure 3B is a section view showing the lower actuation apparatus in an actuated state;

Figure 4A is a section view showing a hydraulically operated downhole tool in an unactuated state;

Figure 4B is a section view showing a hydraulically operated downhole tool in an actuated state; and

Figure 5 is a section view of the upper portion of a hydraulic tool having an explosive member for actuation.

The invention comprises a sidetrack system 100 useful for offsetting a borehole by directing a drill bit or cutter at an angle from the existing borehole. As will be understood by those skilled in the art, however, the principles of the invention can be applied to orient and fix other downhole, hydraulically-actuated tools in a single trip of the drill string. Thus, it being understood that the sidetrack system 100 is merely the preferred embodiment of practising the invention, and that the invention is not limited to a sidetrack system, a preferred embodiment will now be described in greater detail.

Figure 1 is an elevation view, partially in section, of a sidetrack system 100 in accordance with the present invention. The sidetrack system 100 is shown attached at the lower end of a tubular string 200 that is run into a borehole 105 that is lined with casing. The invention is not limited to use in a cased borehole, but is equally applicable to open, noncased boreholes. Thus, throughout this disclosure, the term "borehole" refers both to cased holes and open holes.

Sidetrack system 100 generally includes a MWD device 210, an upper actuation apparatus 300, a window mill 230, a whipstock 500, a lower actuation supporter 600, and a hydraulically operated downhole tool 700. Secondary mill 225 and stabilizer mill 220 aid in formation of the new borehole. At a lower end, whipstock 500 is disposed
5 over an extension member 550 which is fixed to the lower actuation apparatus 700. Extension member 550 is slightly bent at an angle of about $1/2^\circ$ in order to ensure the non-concave side of the whipstock remains flush against the borehole wall 105. At the upper end of apparatus 100 is MWD subassembly 210. To provide the driller with intelligible information at the surface of borehole 105 that is representative of the
10 orientation of the sidetrack system 100, and to provide a variety of other downhole measurements and data, the MWD sub 210 includes a conventional mud pulse telemetry system. The mud pulse telemetry system is well understood by those skilled in the art, thus only a brief description of the system is provided herein. Mud pumps located at the surface of the well circulate drilling mud into the top of the drill string. The mud is
15 conducted through the drill string into MWD sub 210 where it passes through a mud pulser that repeatedly interrupts the mud flow to produce a stream of pressure pulses in the circulating drilling mud that can be detected at the surface by pressure transducers.

After the mud passes through pulser valve in MWD sub 210, it flows through a
20 turbine which provides electrical power for the MWD components. Alternatively, batteries may be used to provide the needed power. Housed in MWD sub 210 are a number of sensors which include a three axis accelerometer which measures the earth's gravitational vector relative to the tool axis and a point along the circumference of the tool called a scribe line (not shown), from which the driller can determine the
25 inclination of MWD sub 24 and "tool face."

The rate of rotation of pulser valve is modulated by an electronic controller in response to a train of signals received from an electronic package. The measurements and data from the various MWD sensors, which are electrically interconnected with
30 electronics package, form discrete portions of the control train of signals sent to controller by electronics package. Thus, the pressure pulses that are received at the surface by transducers are representative of the directional measurements and other data detected downhole by MWD sensors. These signals are then analyzed by computer on a

continuous basis to determine the inclination, azimuth and other pertinent information which is displayed to an operator by means of a monitor and recorded by a recorder. As described hereafter, operation of the MWD can be performed without actuating the downhole tool because a greater amount of pressure is required to actuate the tool than
5 is required to operate the MWD. After operation of the new device, the downhole tool can be actuated prior to separation of the cutter, from the whipstock 500. Whipstock 500 comprises an elongated generally tubular member having an inclined face 505 which, once properly oriented in the borehole, is used to cam window mill 230 into engagement with the casing 105. The interior of whipstock 500 includes a pressure
10 sensing line 400 for transmitting pressure from an upper actuation apparatus 300 to a lower actuation apparatus 600 as will be described fully herein.

In the embodiment illustrated, the downhole tool 700 includes a packer 900 and a anchor 800. Packer 900 is a hydraulically actuated subassembly which, upon
15 actuation, attaches to the borehole casing at a predetermined elevation so as to seal the portion of the borehole below the packer from the portion above it. Anchor 800 is a hydraulically-actuatable mechanism which, upon delivery of a pressurized fluid at a predetermined pressure through internal conduit system becomes set in the casing 105 so as to support whipstock 500. Anchor 800 includes a set of slips and cones that fix
20 the sidetrack system in the borehole.

In the preferred embodiment, the downhole tool 700 is actuated by sequential actions of upper 300 and lower 400 actuation apparatus. The components making up upper actuation apparatus 300 are visible in Figures 2A and 2B. Upper actuation
25 apparatus 300 is installed in a tubular member 301 above window mill 230. The window mill 230 includes a plurality of cutters 231 and flow ports 235 which provide an exit for fluids pumped through tubular member 301 from the well surface. Figure 2A is a section view of upper actuation apparatus 300 in an unactuated state and Figure 2B is a section view of upper actuation apparatus 300 in its actuated state. The
30 apparatus 300 includes a moveable sleeve 310. In the unactuated position illustrated in Figure 2A, the moveable sleeve 310 is attached to an upper stationary portion 305 with a shearable connection 320 comprising at least one shearable member which is constructed and arranged to fail upon application of a certain force thereto. The force

exerted upon the shearable connection is determined by the flow rate of fluid through apparatus 300. While a shearable connection with shear members or pins is used in the preferred embodiment, the invention can be used with any releasable connection means.

5 Moveable sleeve 310 includes restriction 315 in the inner diameter thereof which serves to restrict the flow of fluid through tubular member 301. As fluid passes through upper actuation apparatus 300 and encounters restriction 315, the pressure of the fluid drops in a region 316 directly below restriction 315 and increases in a region 317 directly above restriction 315 thereby creating a pressure differential between the
10 two regions 316, 317. Conversely, the velocity of the fluid decreases in area 317 and increases in area 316. Formed in a wall of tubular member 301 is a pressure port 410. Connected in fluid communication to pressure port 410 through a fitting 405 is a pressure sensing line 400. As depicted in Figure 2A, when the upper actuation apparatus is in its unactuated state, the pressure sensing line is in communication with
15 lower pressure region 316 on the downhole side of restriction 315.

In order to actuate the upper actuation apparatus 300, fluid at a predetermined flow rate is applied through tubular member 301. As the fluid moves through restriction 315, pressure rises in region 317. A certain flow rate will produce a force at restriction
20 315 corresponding to the pressure differential and adequate to overcome the shear strength of the shearable members making up the shearable connection 320. Thereafter, the lower moveable sleeve 310 will move into the position illustrated in Figure 2B.

As shown in Figure 2B, in its actuated position, the upper actuation apparatus
25 300 places pressure sensing line 400 in fluid communication with region 317 of tubular member 301 above the restriction 315. In this manner, the pressure sensing line 400 is exposed to the high side pressure created by the flow of fluid through restriction 315. The pressure sensing line 400 transmits this increased pressure to lower actuation apparatus 600 described hereafter.

30

Using upper actuation apparatus 300, the sidetrack system of the present invention can pass a flow rate of fluid therethrough sufficient to operate a MWD device located in a running string without actuating a hydraulically operated tool therebelow.

After operation of the MWD, the flow rate of fluid can be increased to that level which creates a force sufficient to overcome the shear resistance of shearable connection 320 of the upper actuation apparatus 300 and the downhole tool may then be actuated directly or indirectly.

5

Lower actuation assembly 600 is installed directly above downhole tool 700 and is depicted in Figures 3A and 3B. Figure 3A is a section view showing lower actuation assembly 600 in an unactuated position and Figure 3B shows the assembly 600 in an actuated position. The actuation assembly 600 is installed in the inner bore 612 of a tubular member 601. The assembly comprises a piston 610 which is fixed to inner bore 10 612 with a shearable connection 605 including at least one shear pin 606. Located above piston 610 is area 602 in fluid communication with a pressure bore 401. Pressure bore 401 communicates with pressure sensing line 400 thereabove and places a face 607 of piston 610 in fluid communication with pressurized fluid in pressure sensing line 15 400. Communication between the pressure sensing line 400 and face 607 of piston 610 exposes the piston face to that pressure present in pressure sensing line 400. Shearable connection 605 is designed to withstand a force created by the pressure present in the pressure sensing line 400 while the upper actuation apparatus is in its unactuated position and the pressure sensing line 400 is in communication with lower pressure are 20 316 on the downhole side of restriction 315 (Figure 2A).

When shearable connection 320 of upper actuation apparatus 300 fails and lower movable sleeve 310 moves to the position illustrated in Figure 2B, the change in observed or communicated pressure creates a force causing shearable connection 605 of 25 lower actuation assembly 600 to fail and piston 610 moves into the position depicted in Figure 3B. Piston 610, on its lower face 608, includes a puncture pin 615 extending downward therefrom which is designed to puncture an atmospheric chamber or rupture disk formed in downhole tool 700 as described hereafter. Also formed in tubular member 601 is at least one access port 620, arranged to place the inner bore 612 of 30 tubular member 601 into fluid communication with borehole fluid present in the annular space between tubular member 601 and borehole 105.

In the present embodiment, lower actuation assembly 600 is constructed and arranged to actuate a hydraulically actuatable downhole tool 700 which utilizes at least one atmospheric chamber therein. Such a downhole tool is illustrated in Figures 4A and 4B. Figure 4A is a section view of a downhole tool in an unactuated position and
5 Figure 4B is a section view of the tool in an actuated position. In the example shown in Figures 4A and 4B, hydraulically actuated downhole tool 700 includes an anchor assembly 800 designed to fix the tool 700 in a borehole and a packer 900 designed to seal an annular area between the tool 700 and the borehole. As shown in Figure 4A, the tool is located in a tubular 701 and includes an inner 712 and an outer piston 715 axially
10 movable within the tubular 701 and an upper piston portion 720, also movable within the tubular 701. Disposed between the upper piston portion 720 and the outer piston 715 is a set of slips 830 which, when forced against the wall of the borehole, anchors the tool in the borehole.

15 A packer 900 with expandable members 905 is located above the anchor and is also actuated by force upon the expandable members from the outer piston 715 and upper piston portion 720. An atmospheric chamber 710 formed inside the tool communicates with borehole fluid at a different pressure when the tool is actuated by failure of a rupture disk 725. While the chamber 710 is referred to as an atmospheric
20 chamber it will be understood that the contents of the chamber need not be at atmospheric pressure but only at some pressure different than the borehole pressure therearound.

Piston areas formed on the inner 712 and outer 715 pistons cause the outer
25 piston 715 to move in relation to the inner piston 712. Slips 830 are urged outwards by sloped surfaces at the bottom of upper piston portion 720 and the top of outer piston 715 to assume that position against the borehole as shown in Figure 4B. Likewise, relative axial movement between the upper piston portion 720 and inner piston 712 compresses the packer elements 905 and seals the annulus between the tool and the borehole. In the
30 embodiment shown, the chamber 710 includes a rupture disk 725 formed at top thereof and designed to expose the atmospheric chamber to the borehole pressure in communication with the interior of the tool through at least one access port 620 (Figure 3A). Figure 4B illustrates the hydraulic tool 700 in its actuated state. Rupture disk 725

of atmospheric chamber 710 has been punctured by puncture pin 615 formed at the bottom of piston 610. In this manner, the interior of atmospheric chamber 710 has been exposed to borehole pressure through a channel formed in part by access port 620. The pressure differential between the atmospheric chamber 710 and the borehole pressure has caused pistons 715, 712 to move relative to one another. Slips 830 have been forced outwards, setting the anchor assembly and fixing the tool in the borehole. Additionally, the movement of the outer piston 715 and upper piston portion 720 has squeezed expandable members 905 of packer 900 causing them to expand and seal the annulus created between the body 705 and the inner wall of casing 105. With the sidetrack system set in place in the borehole and the annulus therearound sealed, the window mill 230 may be separated from whipstock 500 and the formation of the lateral borehole can begin.

The sidetrack system 100 of the present invention, when used with a MWD is operated in the following steps: The apparatus is lowered into the borehole with the MWD, a stabilizer mill 220, a second mill 225, the upper actuation apparatus 300 and the window mill 230 arranged in series in the string of drill pipe. A shearable connection 250 connects the window mill to whipstock 500 and at the lower end of whipstock 500 an extension 550 connects the whipstock 500 to lower actuation apparatus 600 and also ensures that whipstock 500 is positioned properly against the wall of borehole 105. Below lower actuation apparatus 600 is hydraulically actuated downhole tool 700 including packer 900 and anchor 800.

After the apparatus 100 is at a predetermined depth in the borehole, the MWD device is operated by well fluid flowing therethrough. As the MWD device operates, well fluid travels down tubular string 200, through upper actuation apparatus 300, into window mill 230 and exits through flow ports 235. Throughout the operation of the MWD, the shearable connection 320 of the upper actuation apparatus 300 withstands forces generated by fluid flowing therethrough and pressure sensing line 400 continues to sense pressure on the downhole side of restriction of 315.

After the MWD device operation has been completed, the flow rate of fluid is increased and the force generated by the flowing fluid upon restriction 315 causes the

shearable connection 320 to fail and the lower moveable sleeve 310 to break free and move downward in the tubular member 301 to a second position. At this point, pressure sensing line 400 is exposed to the uphole pressure generated by fluid flow against restriction 315. The pressure and pressure sensing line 400 is a predetermined pressure adequate to cause shearable connection 605 holding piston 610 in place in lower actuation assembly 600. As shear pin 606 fails and piston moves to a second position within tubular member 601, the frangible member sealing the atmospheric chamber of the downhole tool is ruptured and the atmospheric chamber is exposed to fluid at borehole pressure via access ports 620. The pressure differential between the atmospheric chamber and borehole fluid causes the annular piston in the hydraulically operated downhole tool 700 to move towards the surface of the well, thereby actuating packer 900 which seals the annular area between the tool and the casing wall and anchor 800 which fixes the downhole tool vertically in the casing wall.

While the atmospheric chamber 710 formed in downhole tool 700 relies upon a puncture pin in the embodiment disclosed herein, it will be understood that the rupture disk of the downhole tool could be caused to fail in any number of ways and the invention is not limited to an apparatus specifically relying upon a puncture pin. For example, Figure 5 is a section view of the upper portion of a hydraulic tool 950 with an explosive member used for actuation. Specifically, an explosive charge 960 is disposed directly above rupture disk 965. In order to cause the rupture disk 965 to fail and fluid in atmospheric chamber 970 to be exposed to borehole pressure through ports 975, the explosive charge 960 is detonated using an electrical signal which travels in an electrical wire 980.

25

CLAIMS:

1. An apparatus for actuating a downhole tool comprising:
a first conduit for flowing fluid therethrough;
5 a pressure sensing line in communication with the first conduit; and
the pressure sensing line sensing pressure in the first conduit and communicating
a predetermined pressure to the downhole tool to actuate the downhole tool.
2. An apparatus as claimed in claim 1, where the first conduit includes a pressure
10 charging restriction therein for creating a greater pressure in the conduit thereabove than
therebelow.
3. An apparatus as claimed in claim 2, wherein the restriction is movable from a
first to a second position within the first conduit.
15
4. An apparatus as claimed in claim 3, whereby movement of the restriction from
the first to the second position exposes the pressure sensing line to the greater pressure.
5. An apparatus as claimed in claim 2, 3 or 4, whereby when the greater pressure
20 reaches a predetermined pressure, the downhole tool is actuated.
6. An apparatus as claimed in claim 2, 3, 4 or 5, wherein the pressure sensing line
and the restriction are movable relative to one another.
- 25 7. An apparatus for actuating a downhole tool comprising:
a conduit for flowing fluid therethrough;
a restriction within the conduit arranged so that the fluid has a lower pressure
below the restriction and a greater pressure above the restriction, the restriction movable
from a first position to a second position within the conduit upon a predetermined
30 increase in the fluid flow therethrough;
a pressure sensor in fluid communication at an upper end with the conduit
proximate the restriction, the sensor carrying the lower pressure when the restriction is

in the upper position and the greater pressure when the restriction is in the lower position; and

a piston having a piston surface in fluid communication with a lower end of the pressure sensor, the piston constructed and arranged to move from a first to a second position upon the predetermined increase in the fluid flow through the restriction.

8. An apparatus as claimed in claim 7, further including a hydraulically operated tool disposed below the apparatus, the hydraulically operated tool actuatable by the movement of the piston to the second position.

10

9. An apparatus as claimed in claim 8, wherein the hydraulically operated tool is an anchor and the movable member cooperates with at least one gripping member of the anchor to engage the anchor with a borehole wall.

15

10. An apparatus as claimed in claim 8 or 9, wherein the hydraulically operated tool includes a packer and the movable member cooperates with an opposing surface to actuate packer material and seal an annular area around the packer.

11. An apparatus as claimed in claim 8, 9 or 10, wherein the piston further includes a second surface having a projection for puncturing an atmospheric chamber formed within the hydraulically operated tool.

12. An apparatus as claimed in claim 11, wherein the atmospheric chamber of the hydraulically operated tool is arranged to be exposed to a borehole pressure by the movement of the piston to the second position so that the borehole pressure acts upon a piston surface of the hydraulically operated tool to move a movable member within the tool from a first position to a second position.

13. An apparatus as claimed in any of claims 7 to 12, further including a cutter disposed below the restriction.

14. An apparatus as claimed in claim 13, further including a whipstock disposed between the cutter and the piston.

15. A two position, flow through piston assembly for actuating a hydraulically actuated tool in a borehole, the assembly comprising:

a housing;

5 a piston member disposed within the housing in a first position;

a restriction formed within the piston, the restriction allowing the flow of fluid therethrough while creating a higher pressure area thereabove and a lower pressure area therebelow, the piston movable to a second position when the higher pressure is increased to a predetermined level; and

10 a pressure sensor, the first end of which is attached to the body proximate the piston the pressure sensor carrying the lower pressure when the piston is in the first position and the higher pressure when the piston is in the second position, the second end of the pressure sensor attached proximate a hydraulically operated tool and constructed and arranged to actuate the tool when the piston moves to the second position.

15

16. A hydraulically actuatable downhole tool comprising:

an outer body for disposal in a tubular;

at least one piston formed within the body having a first and second position therein; and

20 an atmospheric chamber formed within the tool for creating a pressure differential between the contents of the chamber and a borehole pressure, the chamber having a rupture disk at an upper end thereof; the tool being arranged so that when the rupture disk fails, the pressure differential causes the at least one piston to move to the second position, thereby actuating the tool.

25

17. A tool as claimed in claim 16, wherein the tool is an anchor and includes at least one gripping member that is set by movement of the at least one piston.

30 18. A tool as claimed in claim 16, wherein the tool is a packer with an expandable portion that is set by the movement of the at least one piston.

19. A tool as claimed in claim 16, 17 or 18, wherein the rupture disk is rupturable by an explosive device located proximate the rupture disk and controlled by an electrical signal.
- 5 20. A method of setting a hydraulically-actuatable mechanism and commencing drilling in a single trip of a drill string comprising the steps of:
- assembling a drill string having a MWD subassembly capable of detecting downhole parameters and communicating the detected data to the surface of the borehole, a pressure sensing line for actuating the hydraulically-actuatable mechanism;
 - 10 running the assembled drill string in the borehole and positioning the hydraulically-actuatable mechanism at a predetermined location;
 - sensing the orientation of the drill string using the MWD subassembly;
 - orienting the drill string in the desired orientation;
 - changing the pressure in the drill string whereby the pressure sensing line sets
 - 15 the hydraulically-actuatable mechanism; and
 - lowering, lifting and/or rotating the drill string to release the cutter assembly from the hydraulically-actuatable mechanism and to commence drilling.

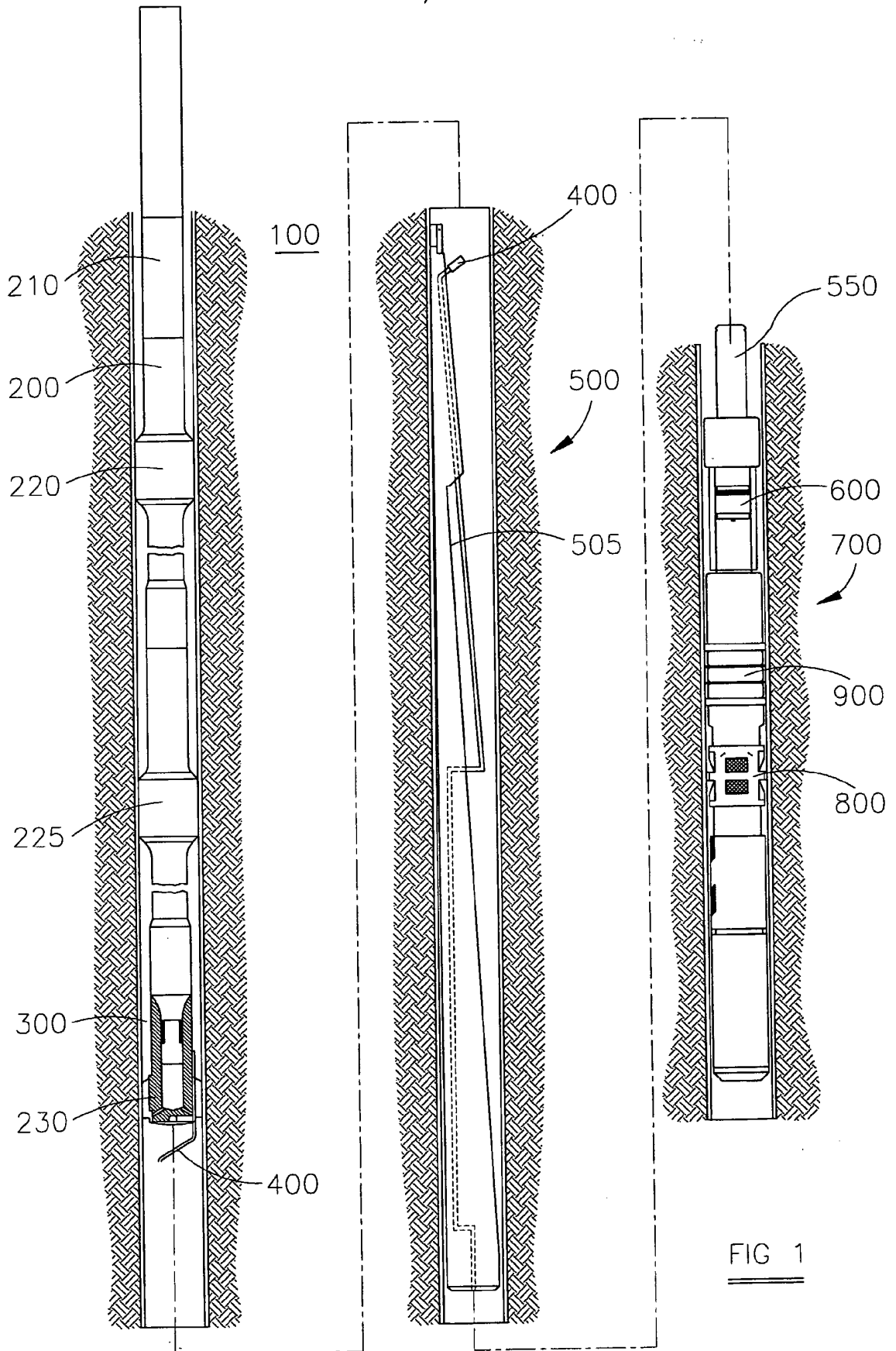

FIG 1

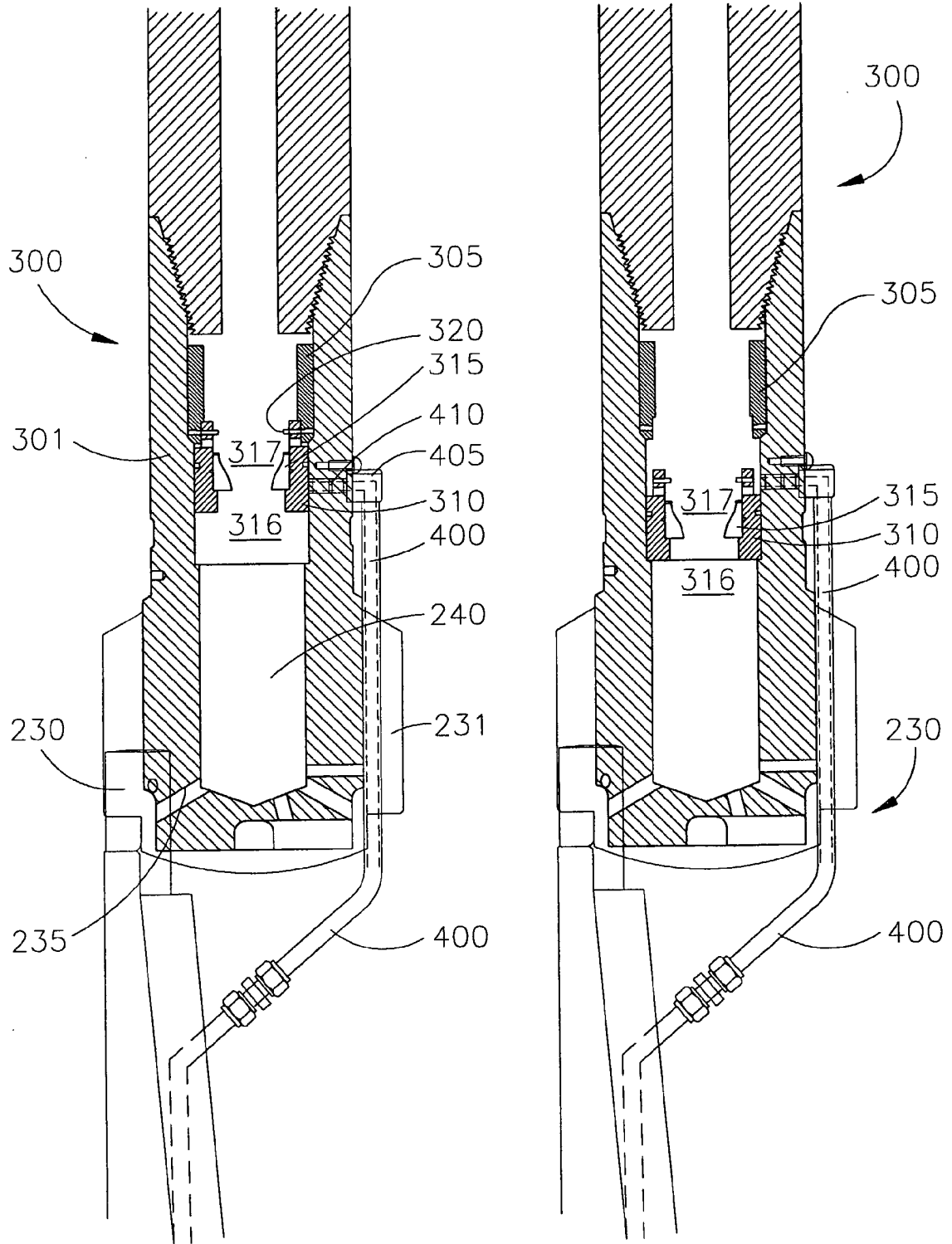

FIG 2A

FIG 2B

3 / 7

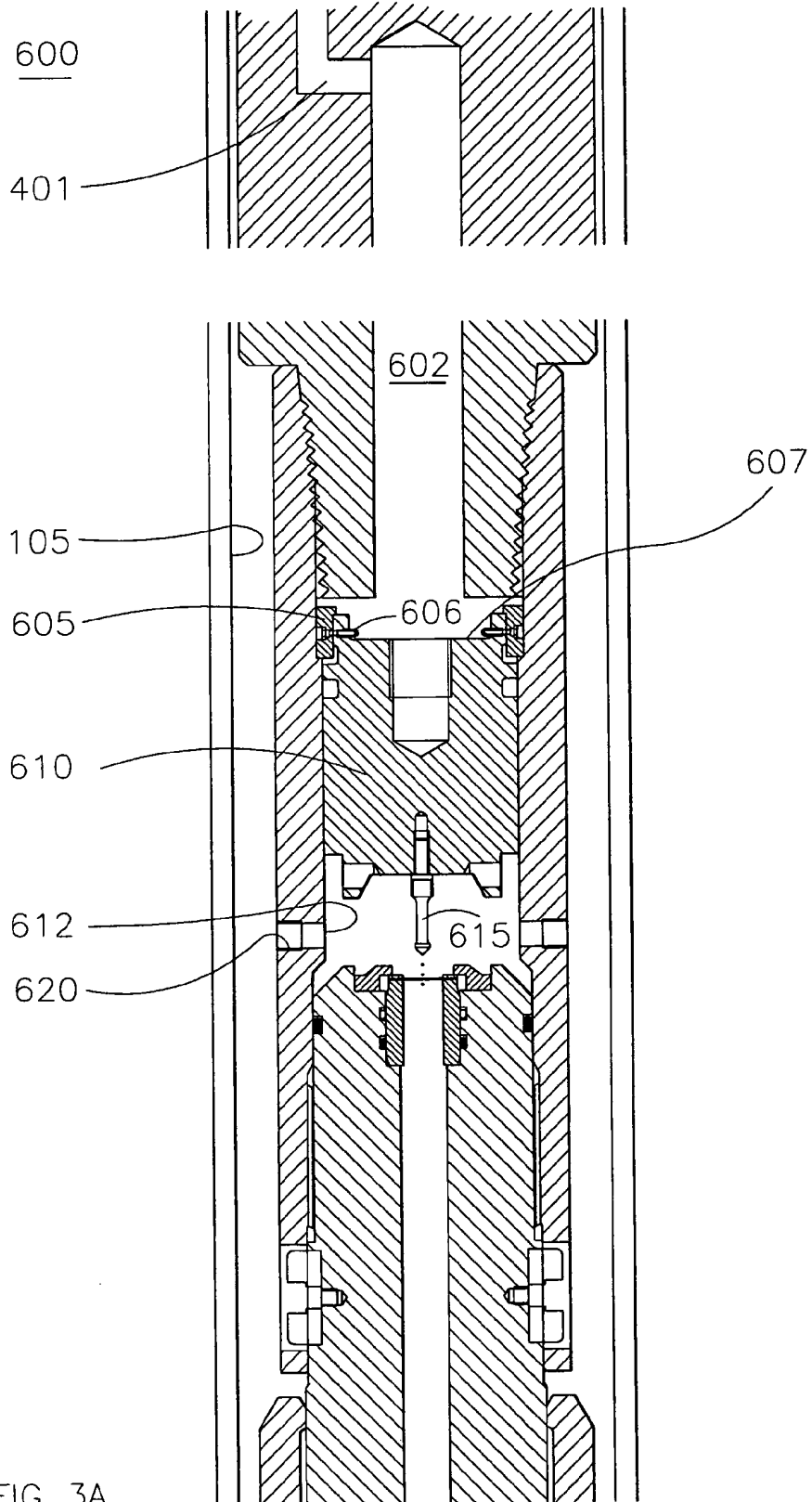
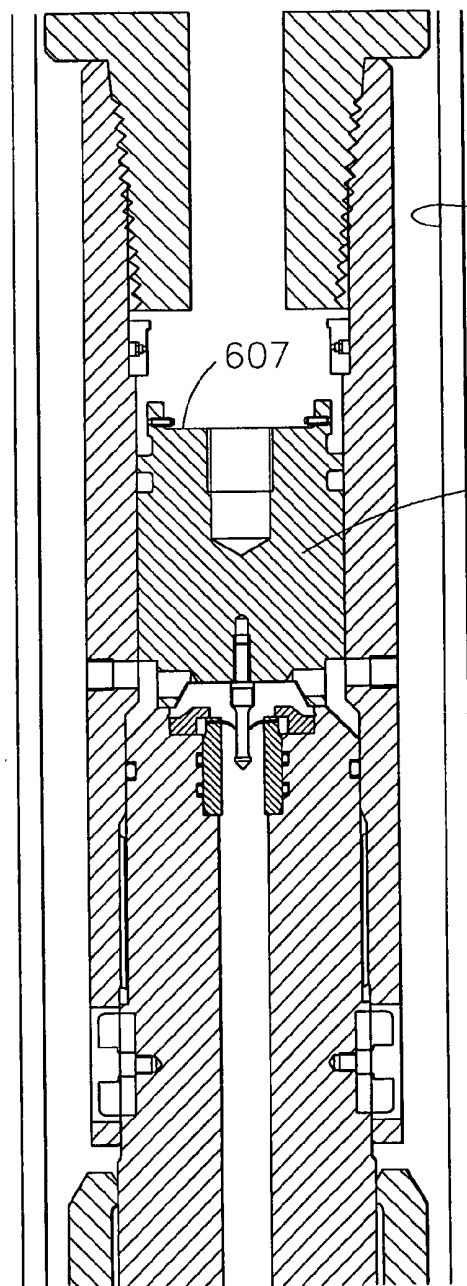
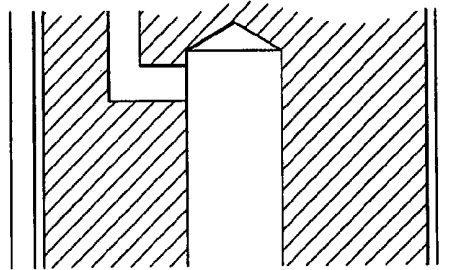

FIG 3A

4 / 7

600



105

607

610

FIG 3B

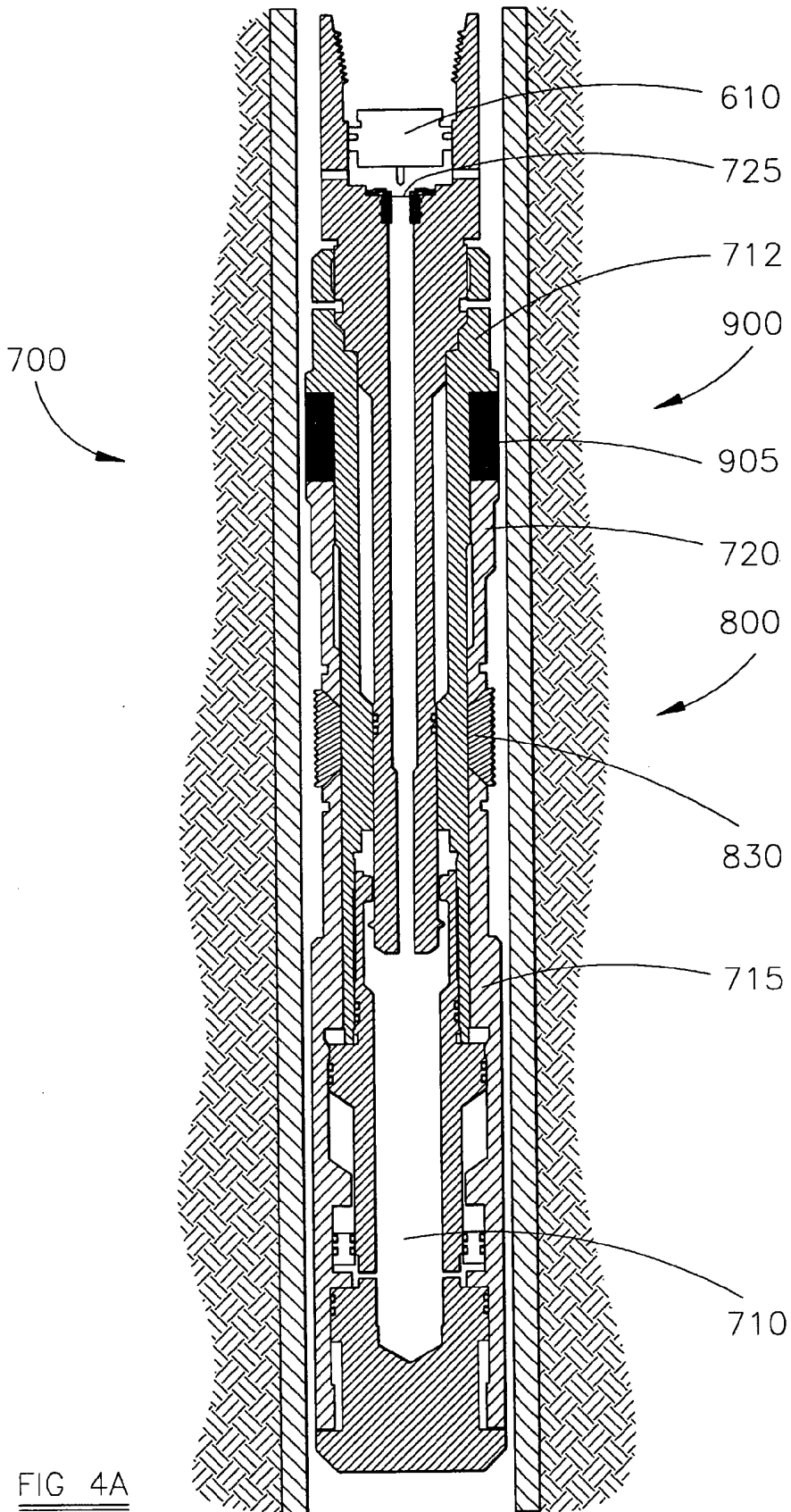

FIG 4A

6 / 7

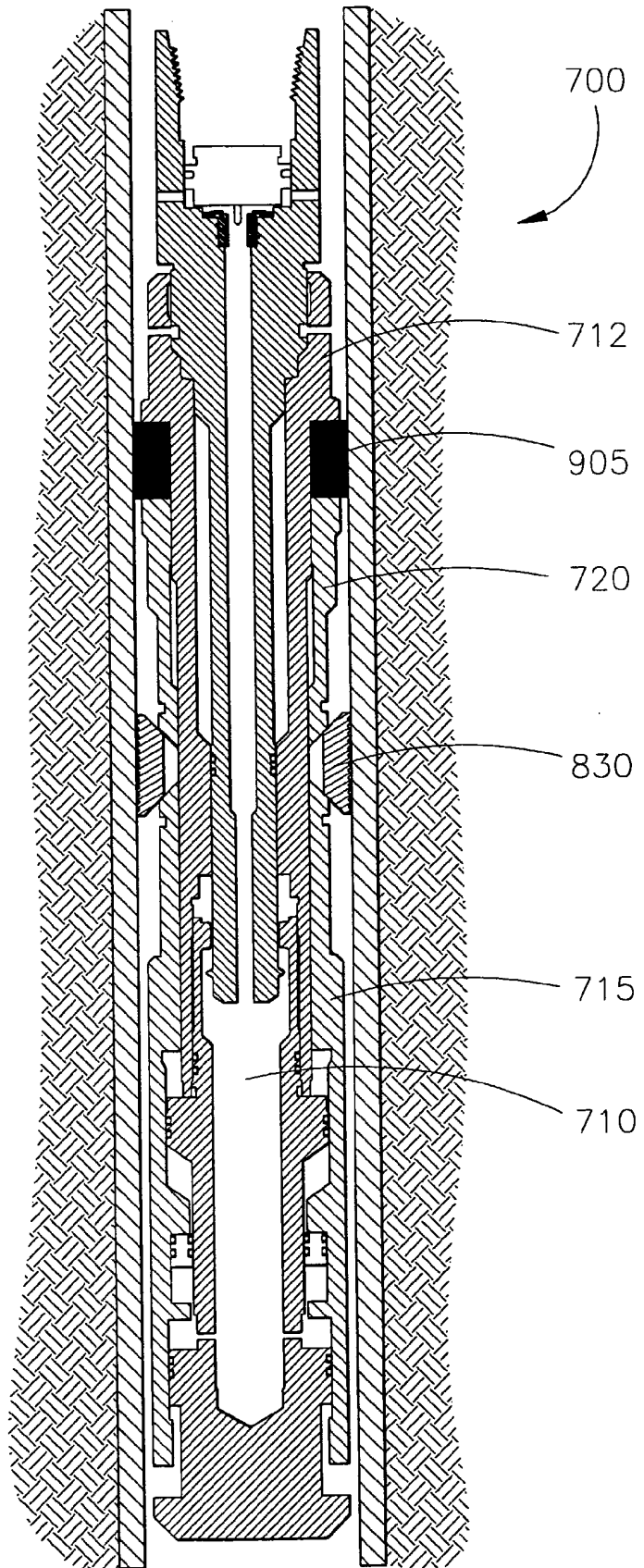

FIG 4B

7 / 7

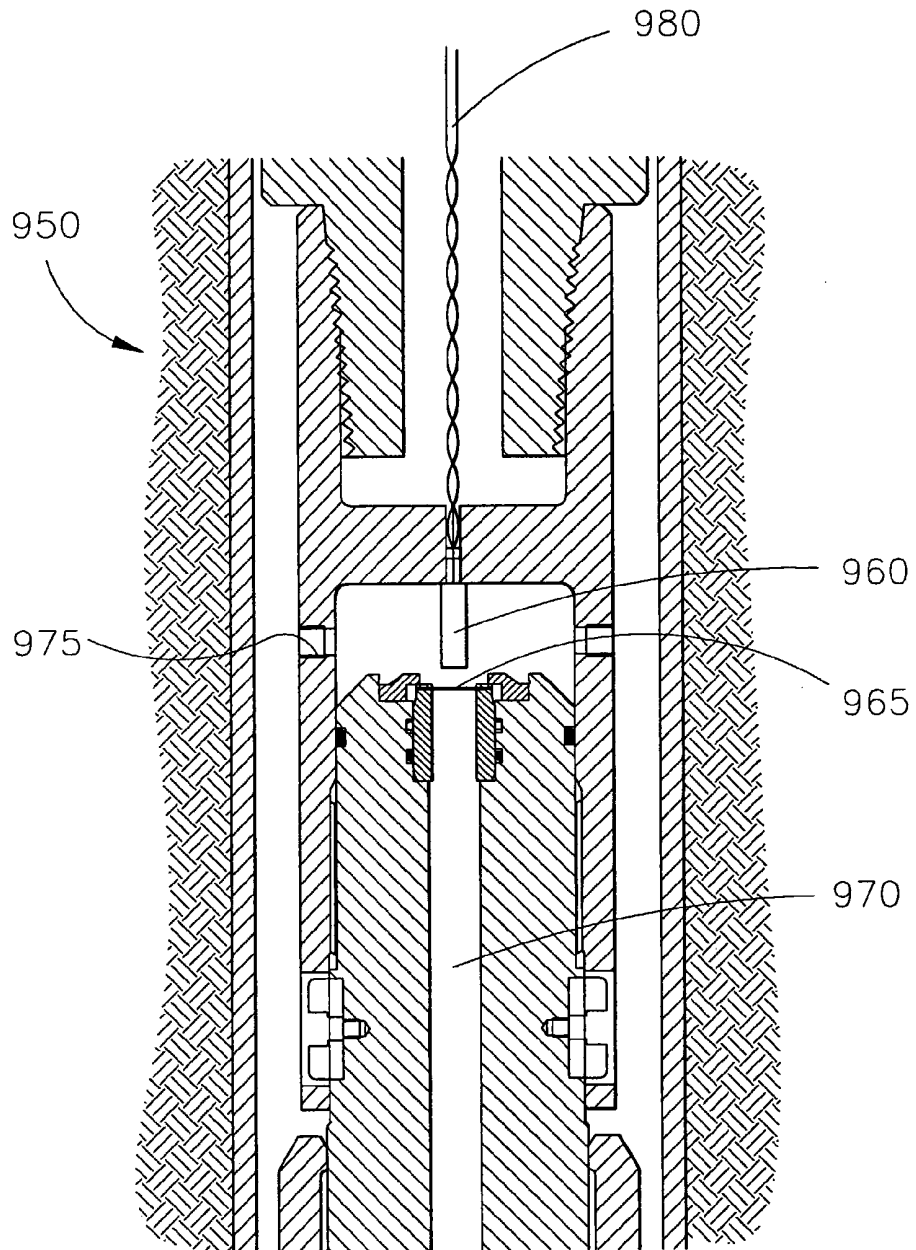

FIG 5