



(51) International Patent Classification:

H04W 48/18 (2009.01) H04W 4/02 (2009.01)
H04L 29/08 (2006.01) H04W 64/00 (2009.01)
G06Q 30/02 (2012.01)

(21) International Application Number:

PCT/EP2017/059252

(22) International Filing Date:

19 April 2017 (19.04.2017)

(25) Filing Language:

English

(26) Publication Language:

English

(30) Priority Data:

1607947.7 06 May 2016 (06.05.2016) GB

(71) Applicant: IP.ACCESS LIMITED [GB/GB]; Building 2020, Cambourne Business Park, Cambourne, Cambridge Cambridgeshire CB23 6DW (GB).

(72) Inventors; and

(71) Applicants (for US only): HARROW, James [GB/GB]; 25 Cherry Orchard, Fulbourn, Fulbourn, Cambridge Cambridgeshire CB21 5EH (GB). BROCK, David [GB/GB]; 65A Shelford Road, Trumpington, Trumpington, Cambridge Cambridgeshire CB2 9NB (GB).

(74) Agent: WRAY, Antony; Optimus Patents Limited, Peak Hill House, Steventon, Basingstoke Hampshire RG25 3AZ (GB).

(81) Designated States (unless otherwise indicated, for every kind of national protection available): AE, AG, AL, AM, AO, AT, AU, AZ, BA, BB, BG, BH, BN, BR, BW, BY, BZ, CA, CH, CL, CN, CO, CR, CU, CZ, DE, DJ, DK, DM, DO, DZ, EC, EE, EG, ES, FI, GB, GD, GE, GH, GM, GT, HN, HR, HU, ID, IL, IN, IR, IS, JP, KE, KG, KH, KN, KP, KR, KW, KZ, LA, LC, LK, LR, LS, LU, LY, MA, MD, ME, MG, MK, MN, MW, MX, MY, MZ, NA, NG, NI, NO, NZ, OM, PA, PE, PG, PH, PL, PT, QA, RO, RS, RU, RW, SA, SC, SD, SE, SG, SK, SL, SM, ST, SV, SY, TH, TJ, TM, TN, TR, TT, TZ, UA, UG, US, UZ, VC, VN, ZA, ZM, ZW.

(84) Designated States (unless otherwise indicated, for every kind of regional protection available): ARIPO (BW, GH, GM, KE, LR, LS, MW, MZ, NA, RW, SD, SL, ST, SZ, TZ, UG, ZM, ZW), Eurasian (AM, AZ, BY, KG, KZ, RU, TJ, TM), European (AL, AT, BE, BG, CH, CY, CZ, DE, DK, EE, ES, FI, FR, GB, GR, HR, HU, IE, IS, IT, LT, LU, LV, MC, MK, MT, NL, NO, PL, PT, RO, RS, SE, SI, SK, SM, TR), OAPI (BF, BJ, CF, CG, CI, CM, GA, GN, GQ, GW, KM, ML, MR, NE, SN, TD, TG).

(54) Title: NETWORK ENTITIES, A WIRELESS COMMUNICATION SYSTEM AND A METHOD FOR PROVIDING SELECTIVE FEATURES TO MOBILE HANDSETS

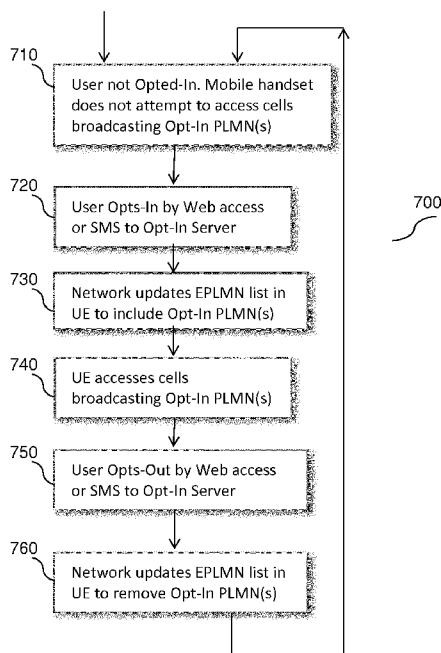

FIG. 7

(57) Abstract: A method for at least one mobile network operator to provide selective features to at least one mobile handset is described. The method comprises, at a Network Operator allocating at least one public land mobile network, PLMN, identifier, ID, to at least one service offered by the at least one mobile network operator, wherein the allocated PLMN ID is distinct from said mobile network operator's normal PLMN ID; and assigning the at least one PLMN ID as an Equivalent PLMN (EPLMN) ID for Opted-In mobile handsets only. The method further comprises, at the at least one base station: broadcasting the at least one distinct PLMN ID; and supporting provision of a range of services to the at least one mobile handset on an individual opt-in or opt-out basis based on the assigned EPLMN ID. In this manner, a provision of user control of opt-in or opt-out of particular services is supported, such that individual mobile handsets will discover and access the appropriate base stations to access services. In this manner, end users are able to control whether their handset automatically provides access to particular services provided by the network operator.

WO 2017/190953 A1

Declarations under Rule 4.17:

- *as to the applicant's entitlement to claim the priority of the earlier application (Rule 4.17(iii))*

Published:

- *with international search report (Art. 21(3))*

NETWORK ENTITIES, A WIRELESS COMMUNICATION SYSTEM AND A METHOD FOR PROVIDING SELECTIVE FEATURES TO MOBILE HANDSETS.

5 **Field of the invention**

The field of this invention relates to network entities, a wireless communication system and methods therefor and particularly to a method for providing selective features or services to wireless communications units. The field of this invention relates to allowing 'opt-in' capability, e.g. for presence applications.

Background of the Invention

15 Wireless communication systems, such as the 3rd Generation (3G) of mobile telephone standards and technology, are well known. An example of such 3G standards and technology is the Universal Mobile Telecommunications System (UMTS™), developed by the 3rd Generation Partnership Project (3GPP™) (www.3gpp.org). The 3rd generation of wireless communications has generally been developed to support macro-cell mobile phone communications. Such macro cells utilise high power base stations (NodeBs in 3GPP™ parlance) to communicate with wireless communication units within a relatively large geographical coverage area. Typically, mobile wireless communication units, or User Equipment (UEs) as they are often referred to in 3G parlance, communicate with a Core Network (CN) of the 3G wireless communication system via a Radio Network Subsystem (RNS). A wireless communication system typically comprises a plurality of radio network subsystems, each radio network subsystem comprising one or more cells to which UEs may attach, and thereby connect to other communication units within, or through, the wireless communication system. 3GPP™ has recently proposed a Long Term Evolution (LTE) solution, namely, an Evolved Universal Mobile Telecommunication System Terrestrial Radio Access Network, (E-UTRAN), for a mobile access network, and a System Architecture Evolution (SAE) solution, namely, an Evolved Packet Core (EPC), for a mobile core network.

30 User Equipment (UE) can access a core network through a 2G/3GRAN such as the (Enhanced Data Rate for GSM Evolution, EDGE) Radio Access Network (Radio Access Network, GERAN) or a Universal Mobile Telecommunication System Terrestrial Radio Access Network (Universal Mobile Telecommunication System Terrestrial Radio Access Network, UTRAN), and access the EPC through the E-UTRAN. Generally, the Core Network is responsible for switching and routing voice calls and data to and from wired telephone networks or the Internet. A RAN is located between the Core Network and the UE.

Operators are seeking to exploit their radio spectrum by providing micro-location based tracking of anonymised UEs in their networks. The operators already provide large-scale macro location insights using probes to monitor which UEs are using which macro cells and then combine

this with other data sources (such as their CRM information, billing data and the web sites that the users visit). By combining these data sets in an anonymised form they can provide valuable data insights into what type of consumer visits what areas and what their typical journeys are. These can be provided to governments and transportation providers in order to assist with planning future capacity requirements or to aid in optimising of traffic routes.

Lower power (and therefore smaller coverage area) cells are a recent development within the field of wireless cellular communication systems. Such small cells are effectively communication coverage areas supported by low power base stations. The terms 'picocell' and 'femtocell' are often used to mean a cell with a small coverage area, with the term femtocell being more commonly used with reference to residential small cells. Herein, the term 'small cell' means any cell having a relatively small coverage area (a coverage area less than a typical macro cell) and includes picocells and femtocells. The low power base stations that support small cells are referred to as Access Points (APs), with the term Home Node B (HNBs) or Evolved Home Node B (eHNB) identifying femtocell access points. These small cells are intended to augment the wide area macrocell network and support communications to User Equipment in a restricted, for example, indoor environment. An additional benefit of small cells is that they can offload traffic from the macrocell network, thereby freeing up valuable macrocell network resources.

With the increasing use of small cell HNB type devices instead of macro cells the operators can now provide location data at a much finer granularity (i.e. within a few meters). This has numerous retail applications, such as allowing a retailer to have insight into the type of people who frequent their stores (based on anonymous aggregated sightings). The use of HNB-type devices to provide location information is often referred to as a 'Presence Cell', which works much like a HNB operating in a closed access mode. In this manner, the HNB appears like any other cell in the operator's network in terms of UE reselection behaviour. The Presence Cell would first ask UEs trying to access it for their unique identity and would then reject the UE back to the normal macro network. This can then provide a timestamp, UE identity and location (based on the fact that the coverage area of the Presence Cell is relatively small).

Referring now to FIG. 1, an example of part of a 3G wireless communication system is illustrated and indicated generally at 100, referred to as a 'core network connected mode' and comprises a Node B 102 that supports wireless communications in a macrocell. The Node B 102 is connected with a radio network controller (RNC) 104 which in turn is linked with a Core Network 106 that includes a Mobile Switching Centre and other conventional network elements or subsystems (not shown). A plurality of HNB's are represented in FIG. 1 although only two 110, 125 are shown for the sake of clarity. An example of a typical HNB for use within a 3GPP 3G system may comprise Node-B functionality and some aspects of RNC functionality, as specified in 3GPP TS 25.467. The HNBs 110, 120 provide a radio access network connectivity to the UE 108 using the so-called luh interface to a network Access Controller, also known as a Home Node B Gateway (HNB-GW) 140, which in turn is connected to the MSC of the Core Network 106. An Access Point Management System (AMS) 130 is also connected to the HNB-GW 140 and thereafter to each HNB 110, 120. A presence server 150 is

also connected with the HNB-GW 140. A User Equipment 108 may roam in and out of the coverage areas of the Node B 102 or the HNB's 100, 120 and request access to the Core Network through any one of these access nodes. The HNB-GW 140 provides Presence Indications to the Presence Server 150 that offers a Presence API to presence-based applications that may be subscribed to by a commercial enterprise.

The MSC of the Core Network 106 routes services for both the small cell and macrocell networks of FIG.1. The UE 108 roams between a coverage area of the macrocell network and the coverage areas of the small cell network, with each network utilising the same MSC of the Core Network 106. The MSC is aware of the location area codes (LACs) for the areas covered by the Node B 102 and the HNBs 110, 120. Initially the Core Network 106 allocates a set of LACs to the AMS 130. These are available for use as over-the-air (OTA) programmed LACs and for at least one lu LAC interface. The AMS 130 then decides which of the allocated OTA LACs to assign, initially, to each HNB 110-120. Each HNB 110, 120 is informed of its OTA LAC and of the lu LAC. The AMS 130 also decides which new LACs to assign to each HNB 110, 120 and when to make this change. The AMS 130 is arranged to change the LACs after a pre-set period of time or at variable time periods depending on communications traffic patterns, such as network loading or usage history.

The AMS 130 is configured to monitor the traffic on the small cell networks. The HNB-GW 140 is configured to generate a location presence notification message and send this to the presence server 150 each time it receives a registration request from a UE 108 via any one of the HNB's 110, 120 to which it is linked. A location presence notification message contains information relating to the identity of the UE 108 (e.g. it's IMSI) and the identity of the HNB that received the initial request for registration. The cell identity may be its OTA LAC or some other identifier derived from this. The presence server 150 may then map an HNB identifier to a geographic location or some other identifier useful to presence applications.

In some geographic territories there are very strict data privacy requirements that must have user opt-in permissions granted before data can be transmitted. For example in some countries it would be forbidden to send a short message service (SMS) message with a voucher to a user when they enter a store. Users in these territories must first explicitly 'opt-in' to such a service before they can be targeted. In other territories the users are 'opted-in' by default, and may have to explicitly 'opt-out' if they did not want to receive such SMS messages. There is therefore a legislative need for the users to be able to 'opt-in' or 'opt-out' from such a service.

In order to use network resources more efficiently, it is known for multiple Core Networks belonging to different Operators to share a common RAN, referred to as a Multi-Operator Core Network (MOCN). The design goal of MOCN is that the RAN broadcasts multiple public land mobile network (PLMN) Identities and UEs can request to attach/update to the identity that they see as the most appropriate (which would typically be their Home PLMN in their home country). A PLMN is any wireless communications system intended for use by terrestrial subscribers in vehicles or on foot. Such a system can stand alone, but often it is interconnected with a fixed system such as the public switched telephone network (PSTN). To this end, the RAN broadcasts Multiple PLMN IDs in the

Multiple PLMN List information element (IE) of the Master Information Block, as described in the 3GPP 25.331 RRC specification Release 6. Those UEs conforming to earlier 3GPP specifications only interpret the original 'PLMN Identity' IE in the Master Information Block.

5 Equivalent PLMN (EPLMN) is a known mechanism for informing a UE that a PLMN Identity broadcast by a network in the Master Information Block should be considered equivalent to the PLMN to which the UE is currently registered. EPLMN dates back to Release 99 specifications and is thus supported by all current UEs. It can be relayed to a UE when a UE registers or performs an Area update (LA update, RA Update) to a network. If one (or more) EPLMN(s) are sent then they only have a 'lifetime' of the current registration, i.e. if not repeated on the next Area update the EPLMN(s) are
10 deleted. Equivalent Home PLMN (EHPLMN) is a known mechanism for informing a UE that a PLMN broadcast by the network should be considered Equivalent to the UE's Home PLMN. EHPLMNS(s) are configured in the USIM (preconfigured or updated over-air). USIM support for EHPLMN (via Elementary File EF_{EHPLMN}) was only introduced in Release 7 31.102 and may not be supported by all UEs (strictly UE & USIM combination). Both mechanisms are intended for network sharing of various
15 forms. Examples include operator usage of different PLMN IDs for 2G & 3G; and operator mergers resulting in multiple different broadcast identities during network consolidation.

A UE that supports network sharing (termed a 'supporting UE') is configured to select a particular Core Network (CN) as its 'serving Core Network' in the shared network and to signal this selection to the RAN (via a HNB-GW or RNC) to which the UE is attached. The RAN will then
20 automatically route the registration for this UE to the selected Core Network. A supporting UE bases its CN selection on additionally broadcast MOCN system information (the Multiple PLMN List mentioned above). However, a UE not supporting network sharing (termed a 'non-supporting UE') ignores such additional system information and leaves Core Network selection to the RAN. Conventionally, a RAN bases its Core Network selection on a Network Resource Indicator (NRI)
25 initially received from the UE. A description of registration processes for supporting and non-supporting UE's can be found in 3GPP TS 23.251 In the case of non-supporting UE's the registration request is speculatively sent to an Operator and then redirected to further Operators until one is found that will accept the UE. This process is undesirable as it increases load on both the RAN and Core Networks and lengthens set-up time.

30 Thus, a need exists for an improved method and apparatus to handle opt-in to certain services, whilst also considering some of the scenarios above, such as shared networks and handling older UEs (i.e. 'non-supporting UEs') that are unable to decode the 'Multiple PLMN List' information element, which mitigates the aforementioned disadvantages.

35 **Summary of the invention**

Aspects of the invention provide a method for at least one mobile network operator to provide selective features to at least one mobile handset, a presence collector, a base station and a communication system as described in the appended claims.

In a first aspect of the invention, a method for at least one mobile network operator to provide selective features to at least one mobile handset is described. The method comprises, at a Network Operator allocating at least one public land mobile network, PLMN, identifier, ID, to at least one service offered by the at least one mobile network operator, wherein the allocated PLMN ID is distinct
5 from said mobile network operator's normal PLMN ID; and assigning the at least one PLMN ID as an Equivalent PLMN (EPLMN) ID for Opted-In mobile handsets only. The method further comprises, at the at least one base station: broadcasting the at least one distinct PLMN ID; and supporting provision of a range of services to the at least one mobile handset on an individual opt-in or opt-out basis based on the assigned EPLMN ID. In this manner, a provision of user control of opt-in or opt-out of particular
10 services is supported, such that individual mobile handsets will discover and access the appropriate base stations to access services. In this manner, end users are able to control whether their handset automatically provides access to particular services provided by the network operator. The Network Operator is the owner of the list of PLMN IDs and allocates the PLMN ID as a policy or management decision.

15 In an optional example, the method may further comprise, at a mobile handset: effecting opt-in or opt-out by sending a short message service, SMS, message to the at least one mobile network operator or via a web portal that updates an opt-in or opt-out status of the mobile handset.

In an optional example the method may further comprise updating an opt-in or opt-out list of allowed, assigned EPLMNs to a plurality of mobile handsets via universal subscriber identity module, USIM, updates of Equivalent HPLMN, and/or updating a list of allowed, assigned EPLMNs to a
20 plurality of mobile handsets via at least one registration message.

In an optional example, supporting provision of a range of services to the at least one mobile handset on an individual opt-in or opt-out basis based on the assigned EPLMN ID may comprise supporting opt-in access to Core Network-based services via a Core Network connection.

25 In an optional example the method may further comprise broadcasting the allocated EPLMN to the plurality of users to enable any requesting end user that has previously opted-in to receive the at least one service feature via the base station.

In an optional example supporting provision of a range of services to the at least one mobile handset on an individual opt-in or opt-out basis based on the assigned EPLMN ID may comprise
30 supporting opt-in access to network-based services via a cell shared by multiple Operators, and/or supporting opt-in access to presence services. In an optional example, the method may further comprise, at the at least one base station: access to the base station by the mobile handset being considered an automatic trigger for presence notification.

In an optional example, the at least one base station may be coupled to (or comprise) a
35 presence collector, wherein the method further comprises, at the base station: receiving and processing presence sightings for multiple Network Operators to obtain presence sighting information and forwarding this information to the presence collector; and at the presence collector, routing presence sighting information to the relevant Network Operator's data analytics system. For example, receiving and processing presence sightings to obtain presence sighting information may comprise:

receiving a mobile handset identity (e.g. an International Mobile Subscriber Identity (IMSI) or temporary mobile subscriber identity (TMSI)); and extracting a first subset of digits (for example 5-6 digits) of the mobile handset's identity to derive the home PLMN (HPLMN) or using an address of a target PLMN provided by the handset. In an optional example, at the base station, the method may
5 further comprise applying an Operator-specific hash function to obscure the mobile handset identity and the Presence Collector forwarding the hashed mobile handset identity to the at least one Network Operator, selected based on a PLMN identity relayed by the base station. In some examples, it is preferable to hash inside the base station (e.g. HNB) rather than transferring un-hashed data to the Presence Collector. Since the base station knows the Operator target (from IMSI, etc.) it can apply the
10 relevant hashing parameters to the data.

In an optional example, supporting an opt-in presence service to end users based on the allocated EPLMN may be performed without involvement of a connection to a core network of a cellular communication system.

In an optional example, the EPLMN may be an equivalent HPLMN (EHPLMN).

15 According to a second aspect of the invention, a base station supporting a presence cell (e.g. in a form of a HNB or a HeNB) comprising: a transceiver; and a signal processor operably coupled to the transceiver is described. The signal processor is configured to: receive a mobile handset International Mobile Subscriber Identity (IMSI) or temporary mobile subscriber identity (TMSI) or a hashed equivalent of the IMSI or TMSI; obtain a public land mobile network, PLMN, identity associated with
20 the mobile handset; and send the hashed identity and the PLMN identity to a presence collector for relay to an appropriate Network Operator.

According to a third aspect of the invention, a base station for supporting a provision of selective features to mobile handsets is described. The base station comprises: a transmitter for communicating with a plurality of mobile handsets and configured to broadcast at least one allocated PLMN ID that is
25 associated with at least one service offered by at least one mobile network operator, wherein the at least one allocated PLMN ID is distinct from a mobile network operator's normal PLMN ID; and a processor, operably coupled to the transmitter and configured to support provision of the at least one service to at least one mobile handset on an individual opt-in basis based on the at least one allocated PLMN ID that is assigned as an Equivalent PLMN (EPLMN) for Opted-In mobile handsets only. In an
30 optional example, the base station may be at least one from an evolved Node B (eNB), a Home Node B (HNB).

According to a fourth aspect of the invention, a wireless communication system comprises at least one base station, at least one mobile handset and at least one mobile network operator, wherein the wireless communication system is configured to provide selective features to the at least one
35 mobile handset. The Operator Network is configured to: allocate at least one public land mobile network, PLMN, identifier, ID, to at least one service offered by the at least one mobile network operator, wherein the allocated PLMN ID is distinct from said mobile network operator's normal PLMN ID; and assign the at least one PLMN ID as an Equivalent PLMN (EPLMN) ID for Opted-In mobile handsets only. The at the at least one base station is configured to: broadcast the at least one distinct

PLMN ID; and support provision of a range of services to the at least one mobile handset on an individual opt-in or opt-out basis based on the assigned EPLMN ID.

These and other aspects, features and advantages of the invention will be apparent from, and elucidated with reference to, the embodiments described hereinafter.

5

Brief Description of the Drawings

Further details, aspects and embodiments of the invention will be described, by way of example only, with reference to the drawings. Elements in the figures are illustrated for simplicity and clarity and have not necessarily been drawn to scale. Like reference numerals have been included in the respective drawings to ease understanding.

10

FIG. 1 illustrates a known wireless communication system comprising access point management, a gateway and a presence server.

FIG. 2 illustrates a part of an example wireless communication system comprising multi-operator core networks sharing a common radio access network providing features under opt-in control and operating in accordance with an example embodiment of the invention.

15

FIG. 3 illustrates a part of an example wireless communication system comprising multi-operator core networks with a presence collector and operating in accordance with an example embodiment of the invention.

FIG. 4 illustrates an example block diagram of a base station (for example a HNB or presence cell) configured to operate in accordance with an example embodiment of the invention.

20

FIG. 5 illustrates a part of an example wireless communication system comprising single-operator core networks with a presence collector and operating in accordance with an example embodiment of the invention.

FIG. 6 illustrates a part of an example wireless communication system comprising single-operator core networks sharing a common radio access network and operating in accordance with an example embodiment of the invention.

25

FIG. 7 is a simplified flowchart of an example embodiment of a method of explicit 'opt-in' for mobile handsets in a wireless communication system.

FIG. 8 illustrates a part of an example wireless communication system comprising single-operator core networks sharing a common radio access network and operating in accordance with an example embodiment of the invention.

30

Detailed Description

Examples of the invention propose a mechanism to use a shared PLMN identity associated with a particular service or services, in conjunction with an approach that uses an explicit 'opt-in' by subscriber units. Here, an individual user (identified as a mobile handset or user equipment (UE)) may choose to opt-in to whatever service is offered. This is in contrast to a use of a "Common PLMN" in conventional MOCN, whereby the Network Operators come to a network-sharing agreement that is applied to all of their users/subscribers.

35

Some examples of the inventive concept find applicability in a wireless communication system comprising multiple operators sharing a common radio access network. One known problem of a typical mobile operator based presence solution is that only UEs belonging to a single operator can be detected. Some examples of the inventive concept also find applicability in a wireless communication system comprising a single operator.

However, in accordance with example embodiments of the invention, a use of EPLMN identity or EHPLMN identity is employed and described here that allows multiple operators to share a Presence Service. For example, Home Node Bs are configured to transmit in their broadcast messages a PLMN identity associated with a Presence Service requiring Opt-In. This PLMN identity (sometimes referred to as a Presence PLMN) is configured into the UE of Opted-In users as an EPLMN or EHPLMN. As a consequence, opted-in users/UEs/handsets from one or more network operators recognise this Presence PLMN and attempt to access it, allowing their presence to be detected.

Those UEs that had opted out, or had not explicitly opted-in, would ignore the Home Node Bs broadcasting the Presence PLMN. As the UE does not even attempt to access such a presence service, the need for opted-out data to be deleted after the event is removed. Furthermore, since the UE does not even attempt to access the service, there is a benefit in reduced network signalling and impact to the UE behaviour. As such, the invention has applicability even where the Home Node B services a single Operator.

In some examples, the opt-in/opt-out concepts may be employed for a single Operator, and in some examples this can be extended in various ways to cover multiple operators, non-supporting UEs and can also apply to LTE™ as well as 3G devices.

In one non-presence cell example, therefore, multiple Operators share a cell using a single broadcast 'opt-in PLMN' ID. In this example, each participating Operator supplies the 'opt-in PLMN' ID as an EPLMN to its opted-in UEs. In this manner, non-supporting UEs as well as supporting UEs may recognise any cell using the broadcast 'opt-in PLMN' ID as being equivalent to their normal network and will thus attempt to access the service.

In another example, the different Operators, or even different services of the same operator, may use separate PLMN IDs for the Opt-In services, with each Operator supplying the relevant PLMN IDs as EPLMNs to its Opted-In users and the cell providing Opt-in services broadcasting the multiple PLMN IDs associated with the Opt-In services.

The above examples are distinguished over, say, a conventional MOCN system with multiple PLMN-IDs on-air, as a conventional MOCN system is unable to support such an opt-in feature: namely the participating Operators update their network configuration such that all of their UEs are configured to use the shared cells. In this invention, each individual user is given the control of whether to opt-in to a service, where the access to the service is associated with a distinct PLMN identity separate to that used by the Operator for normal mobile telephony services.

In some examples, the opt-in/opt-out concepts herein described may be applied to existing UEs as well as for new UEs that are, say, compliant with the LTE standard (and where there are no such legacy UEs).

Those skilled in the art will recognise and appreciate that the specifics of the specific examples described are merely illustrative of some embodiments and that the teachings set forth herein are applicable in a variety of alternative settings. For example, implementations within cellular communication systems conforming to different standards are contemplated and are within the scope of the various teachings described.

Network-based Service Opt-in

10

Referring now to FIG. 2, a part of an example wireless communication system comprising multi-operator core networks sharing a common radio access network providing features under opt-in control and operating in accordance with an example embodiment of the invention is illustrated and indicated generally at 200. The example wireless communication system comprises a Core Network Connection whereby the UEs are registered to the cells and receive opted-in services.

15

Three core networks, represented by three MSCs 240, 242, and 244, are operated by three different Operators. Each MSC 240, 242, 244 has a link to a Radio Access Network (RAN) subsystem over the so-called lu interface. A core network may typically comprise many network elements but for clarity purposes only the MSCs are shown in FIG.2. Similarly, a typical RAN may comprise many subsystems. However, for clarity purposes only, just one RAN comprising two network elements is shown in the example of FIG. 1, namely radio network controllers (RNCs) 220, 222, 224 being coupled to respective NodeBs 210, 212, 214. UEs 200, 202, 204 are subscribers of the respective separate operator networks and have chosen to opt-in to specific services in those operator networks.

20

Specifically, the RAN subsystem also comprises two Access Points comprising Opt-in Home Node B (HNB) 230, 232 offering Opt-In service and a Home Node B Gateway (HNB-GW) 250. The Opt-in HNBS 230, 232 and HNB-GW 250 are linked via the so-called luh interface. The HNB-GW 250 is provided with a signal processor and a database in the form of a look-up table. The Opt-in HNBS 230, 232 broadcast a single PLMN ID associated with a service restricted to Opted-In users. This same PLMN-ID is provided to User Equipment (UE) 202, 204, 206 as an EPLMN. The Opt-in HNBS 230, 232 provide a wireless link to one or more User Equipment (UE) 202, 204, 206 over the so-called Uu interface. The Opt-in HNBS 230, 232 provide wireless coverage over a relatively small area, e.g. a femtocell. Thus, when in the coverage area of Opt-in HNBS 230, 232, the UEs 202, 204, 206 will consider the PLMN ID of the HNBS as equivalent to their normal Home PLMN and will access the HNBS to receive service.

25

30

35

Thus, one example of the invention proposes a mechanism to use a shared PLMN in conjunction with an approach that uses an explicit 'opt-in' by subscriber units. Here, an individual user may choose to opt-in to whatever service is offered. This is in contrast to a use of a 'Common PLMN'

in conventional MOCN, whereby the Network Operators come to a network-sharing agreement that is applied to all of their users/subscribers.

Although FIG. 2 is illustrated showing multiple operators and their network services, it is envisaged that the concept described works equally as well with a single operator, as illustrated in FIG. 6.

Service Opt-in with multi-operator presence

Referring now to FIG. 3, a part of an example wireless communication system 300 comprising multi-operator core networks with a presence collector is illustrated operating in accordance with an example embodiment of the invention.

Again, three core networks, represented by three MSCs 340, 342, and 344, are operated by three different Operators. Each MSC 340, 342, 344 has a link to a Radio Access Network (RAN) subsystem over the so-called lu interface. A core network may typically comprise many network elements but for clarity purposes only the MSCs are shown in FIG.2. Similarly, a typical RAN may comprise many subsystems. However, for clarity purposes only, just one RAN comprising two network elements is shown in the example of FIG. 1, namely RNCs 320, 322, 324 being coupled to respective Macro cell NodeBs 310, 312, 314. Thus, Macro cell Node Bs 310, 312, 314 each represent separate operator macro networks. UEs 302, 304, 306 are subscribers of the respective separate operator networks and are opted-in to Presence Service offered by their operator.

Specifically, the RAN subsystem also comprises two Access Points comprising Home Node Bs (HNBs) 330, 332 offering Opt-In Presence service and a Presence collector 360. The Presence collector 360 is provided with a signal processor 361, a transceiver 363 to transmit or receive information (in wireless, wireline or any other form) and optionally a database in the form of a look-up table (not shown), amongst many other components and circuits. The HNBS 330, 332 broadcast a single PLMN ID associated with a Presence service restricted to Opted-In users. This same PLMN-ID is provided to User Equipment (UE) 302, 304, 306 as an EPLMN. The HNBS 330, 332 provide a wireless link to one or more User Equipment (UE) 302, 304, 306 over the so-called Uu interface. The HNBS 330, 332 provide wireless coverage over a relatively small area, e.g. a femtocell. Thus, when in the coverage area of HNBS 330, 332, the UEs 302, 304, 306 will consider the PLMN ID of the HNBS as equivalent to their normal Home PLMN and will access the HNBS to receive service.

When one or more of the UEs 302, 304, 306 moves within coverage of one of HNBS 330, 332, and establishes a communication link therewith, the respective HNB 330, 332 captures the respective UE's International mobile subscriber identity (IMSI)/temporary mobile subscriber identity (TMSI) and passes the UE's IMSI/TMSI or a hashed equivalent of the UE's IMSI/TMSI to Presence Collector 360. The processor 361 of the Presence Collector 360 then performs operator-specific processing & passes, via transceiver 363, the UE's IMSI/TMSI to a respective Presence Server 362, 364, 366, based on the UE's IMSI/TMSI or any other PLMN information provided by the HNB.

In an optional example, providing a range of service features on an opt-in or opt-out basis to end users may comprise an opt-in access to presence services. For example, the method may further

comprise the Presence Collector 360: receiving the end user International Mobile Subscriber Identity (IMSI) or temporary mobile subscriber identity (TMSI); and extracting a first subset of (5-6) digits of the end user's IMSI to derive the home PLMN (HPLMN). In an optional example, the method may further comprise forwarding details of the end user's identity to the presence service to a selected Network Operator's data analytics system (e.g. presence server) based on the HPLMN.

In another example, the different Operators may use separate PLMN IDs for the Opt-In Presence services, with each Operator supplying the relevant PLMN IDs to its Opted-In users and the cell providing Opt-in Presence services broadcasting the multiple PLMN IDs associated with the Opt-In services. In this case the UEs 302, 304, 306 will indicate to the HNBs 330, 332 which PLMN ID they wish to access (the target PLMN). In an optional example, the base station may be coupled to a presence collector and the method may further comprise: receiving presence sightings for multiple Network Operators from the presence collector; and routing to the relevant Network Operator's data analytics system. The HNB 330, 332 relays the target PLMN along with the UE's identity (IMSI/TMSI) to the Presence Collector 360 which will perform operator-specific processing & passes the UE's IMSI/TMSI to a respective Presence Server 362, 364, 366, based on the UE's indication.

In some examples, the HNB 330, 332 may use the UE's IMSI/TMSI prefix (e.g. the first 5 or 6 digits), or the knowledge of target PLMN to determine an operator-specific hash to obscure the identity. The Presence Collector 360 may then relay the hashed identities to the appropriate Operator via the relevant respective Presence Server 362, 364, 366. In some examples, the Presence Collector may be considered as an aggregator of data from lots of Presence Cells and configured to push the data onwards to Operator Analytics systems. In an optional example, providing an opt-in presence service to end users based on the allocated EPLMN may be provided without involvement of a connection to a core network of a cellular communication system.

Referring now to FIG. 4, a block diagram of a wireless communication unit, adapted in accordance with some example embodiments of the invention, is shown. In practice, purely for the purposes of explaining embodiments of the invention, the wireless communication unit is described in terms of a wireless base station 400, such as an Opt-in HNB 230, 232, 330, 332. The base station 400 contains an antenna 402, antenna array, or plurality of antennas for receiving and transmitting signals 421 coupled to an antenna switch or duplexer 404 that provides isolation between receive and transmit chains within the base station 400. One or more receiver chains, as known in the art, include receiver front-end circuitry 406 (effectively providing reception, filtering and intermediate or base-band frequency conversion). The receiver front-end circuitry 406 is coupled to a signal processor 428 (generally realized by a digital signal processor (DSP)). A skilled artisan will appreciate that the level of integration of receiver circuits or components may be, in some instances, implementation-dependent.

The controller 414 maintains overall operational control of the base station 400. The controller 414 is also coupled to the receiver front-end circuitry 406 and the signal processor 428. In some examples, the controller 414 is also coupled to a buffer module 417 and a memory device 416 that

selectively stores operating regimes, such as decoding/encoding functions, synchronization patterns, code sequences, and the like, as well as information related to UEs that it is communicating with. A timer 418 is operably coupled to the controller 414 to control the timing of operations (e.g. transmission or reception of time-dependent signals) within the base station 400.

5 As regards the transmit chain, this essentially includes an input module 420, coupled in series through transmitter/modulation circuitry 422 and a power amplifier 424 to the antenna 402, antenna array, or plurality of antennas. The transmitter/ modulation circuitry 422 and the power amplifier 424 are operationally responsive to the controller 414.

10 In accordance with examples of the invention, base station 400 is configured such that the transmitter and receiver circuits (often referred to as a transceiver) are configured to communicate with a plurality of mobile handsets, e.g. users of UEs 202, 204, 206 or UEs 302, 304, 306 from FIG. 3. In particular, the base station 400 is configured to broadcast at least one allocated PLMN ID that is associated with at least one service offered by at least one mobile network operator, wherein the at least one allocated PLMN ID is distinct from a mobile network operator's normal PLMN ID. The at
15 least one PLMN ID is assigned as an Equivalent PLMN (EPLMN) for Opted-In mobile handsets only by a collection of entities in the Operator network, prior to the mobile handset(s) requesting access to the base station.

In accordance with examples of the invention, memory device 416, operably coupled to the signal processor 428, may be configured to store user-specific data relating to opt-in or opt-out
20 services supported by the base station 400. In particular, the processor is configured to support provision of a range of services to the at least one mobile handset on an individual opt-in or opt-out basis based on the assigned EPLMN ID.

The signal processor 428 in the transmit chain may be implemented as distinct from the signal processor in the receive chain. Alternatively, a single processor may be used to implement a
25 processing of both transmit and receive signals, as shown in FIG. 4. Clearly, the various components within the base station 400 can be realized in discrete or integrated component form, with an ultimate structure therefore being an application-specific or design selection.

Service Opt-in with single-operator presence

30

Referring now to FIG. 5, a part of an example wireless communication system 500 comprising single-operator core networks 540 with a presence collector 560 is illustrated in accordance with an example embodiment of the invention.

Here, a core network, represented by a single MSC 540 is operated by a single Operator. The
35 MSC 540 has a link to a Radio Access Network (RAN) subsystem over the so-called Iu interface. The RAN comprises two network elements, namely RNC 520 coupled to respective Macro cell NodeB 510.

Specifically, the RAN subsystem in this example also comprises two Access Points comprising Home Node Bs (HNBs) 530, 532 offering Opt-In Presence service and a Presence collector 560. The Presence collector 560 is provided with a signal processor and a database in the

form of a look-up table (not shown), amongst many other components and circuits. The HNBs 530, 532 broadcast a single PLMN ID associated with a Presence service restricted to Opted-In users. This same PLMN-ID is provided to User Equipment (UE) 502 as an EPLMN. The HNBs 530, 532 provide a wireless link to one or more User Equipment (UE) 502 over the so-called Uu interface. The HNBs 530, 532 provide wireless coverage over a relatively small area, e.g. a femtocell. Thus, when in the coverage area of HNBs 530, 532, the UE 302 will consider the PLMN ID of the HNBs as equivalent to its normal Home PLMN and will access the HNBs to receive service.

When UE 502 moves within coverage of one of HNBs 530, 532, and establishes a communication link therewith, the respective HNB 530, 532 captures the respective UE's IMSI/TMSI and passes the UE's IMSI/TMSI or a hashed equivalent of the UE's IMSI/TMSI to Presence Collector 560. In essence, in this example, Presence Collector 560 may function as a server that aggregates the UE sightings information from each Presence Cell (e.g. HNB 530, 532) and route the relevant sightings data to the operator for further down-stream processing. In this regard, the Presence Collector 360 then performs operator-specific processing & passes the UE's IMSI/TMSI, or a hashed equivalent of the UE's IMSI/TMSI, to a respective Presence Server (not shown) associated with a Network Operator, based on the UE's IMSI/TMSI or a target PLMN identity passed by the base station.

In some examples, the HNB 530, 532 may use a well-known sequence (such as used for IMSI-based Access Control) to obtain the IMSI of the UE before rejecting the registration in order to send the UE 502 back to the macro network. Alternatively, the HNB 530, 532 may simply capture a TMSI (without issuing an Identity Request) and allow the operator to post-process this to a subscriber identity at a later point.

Network-based Service Opt-in with single-operator

Referring now to FIG. 6, a part of an example wireless communication system comprising a single-operator core network sharing a common radio access network and operating in accordance with an example embodiment of the invention is illustrated and indicated generally at 600. The example wireless communication system comprises a Core Network Connection whereby the UEs are registered to the cells and receive opted-in services.

A single core network, represented by MSC 640 is operated by a single Network Operator. MSC 640 has a link to a Radio Access Network (RAN) subsystem over the so-called Iu interface. A RAN comprises, in this example, two network elements, namely radio network controller (RNC) 620, coupled to respective macro cell NodeB 610. UEs 602, 604 are both subscribers of the Operator Network, but only UE 604 has chosen to opt-in to specific services offered by that Operator Network. Macro cell NodeB 610 represent an Operator's primary macro network offering service to all of its subscribers.

Specifically, the RAN subsystem also comprises two Access Points comprising Opt-In Home Node B (HNB) 630, 632 offering Opt-In service and a Home Node B Gateway (HNB-GW) 650. The Opt-In HNBs 630, 632 and HNB-GW 650 are linked via the so-called luh interface. The HNB-GW 650 is provided with a signal processor and a database in the form of a look-up table. The Opt-In HNBs 630, 632 broadcast a single PLMN ID associated with a service restricted to Opted-In users. This same PLMN-ID is provided to User Equipment (UE) 604 as an EPLMN. The Opt-In HNBs 630, 632 provide a wireless link to one or more User Equipment (UE) 602, 604, over the so-called Uu interface. The Opt-In HNBs 630, 632 provide wireless coverage over a relatively small area, e.g. a femtocell.

In this example, the UE 602 is a subscriber of the Operator Network and is not 'opted-in'. The UE 602 moves into the coverage area of the Opt-In HNB 632. In accordance with example embodiments, Opt-In HNB 632 is configured to broadcast a shared Opt-In PLMN. However, the UE 602 does not view the broadcast opt-in PLMN as an Equivalent PLMN and remains registered on the macro network via NodeB 610.

In contrast, UE 604 is a subscriber of the operator network & is 'opted-in'. The UE 604 moves into the coverage area of the Opt-In HNB 632. In accordance with example embodiments, HNB 632 is configured to broadcast a shared Opt-In PLMN that UE 602 considers an Equivalent PLMN. In response thereto, UE 604 registers to Opt-In HNB 632.

Thereafter, UE 604 is able to obtain one or more opted-in service(s) from Core Network MSC 640.

Referring now to FIG. 7, a simplified flowchart 700 of an example embodiment of a method of explicit 'opt-in' for mobile handsets in a wireless communication system is described. At 710, in this example flowchart, it is assumed that the user/mobile handset has not 'Opted-In'. Thus, at 710, the mobile handset does not attempt to access cells broadcasting the Opt-In PLMN(s). At 720, the mobile handset user Opts-In, say by Web access or sending an SMS to an Opt-In Server. In some examples, the web portal may not necessarily be accessed via the handset, for example the web portal may be a PC-based web access to a customer portal. At 730, the Network Operator (or server) updates the EPLMN list in the mobile handset to include Opt-In PLMN(s). At 740, the mobile handset accesses cells broadcasting Opt-In PLMN(s), in order to receive the opted-in service(s). At 750, the mobile handset user Opts-Out of receiving the service(s), say by Web access or sending a further SMS to the Opt-In Server. At 760, the Network updates EPLMN list in the mobile handset to remove the Opt-In PLMN(s). The flowchart 700 then returns to 710, with the user/mobile handset being not 'Opted-In'.

FIG. 8 illustrates a part of an example wireless communication system 800 comprising at least one Opt-in server operating in accordance with an example embodiment of the invention. In this example, UE 802 may opt-in by any of the following mechanisms:

- (i) send an SMS to an Opt-in SMS number/receiver 840. While this logical path is shown as a dotted line, note that the SMS is actually transferred via the normal macro network communication paths 810, 820, 830 to reach 840,

(ii) by providing their MSISDN phone number via, say a Web (opt-in) server 860, for example where the Opt-In may be added to the operator's existing customer web portal used for managing a user's existing online account.

In this example, Opt-in server 870 may then look up the UE's MSISDN phone number and
5 determine which host operator owns the SIM. In some examples, the Opt-in server 870 may convert UE's MSISDN phone number to the IMSI of the mobile handset. The OTA Update Message generator 880 ensures that the Core Network 830 sends a message or messages to the UE 802 via the normal radio access network, e.g. RNC 820 and Node B 810 to establish the PLMN ID associated with the Opt-In service as an Equivalent PLMN (EPLMN) for the specific UE. In some examples, such an OTA
10 Update to the UE 802 may enable an EPLMN to be permanently stored in the UE's SIM (E-HPLMN), or temporarily stored as an EPLMN that may be refreshed on each Registration. The existence of the EPLMN in the UE 802 means that it will attempt to access a cell that is publishing an Opt-in service by broadcast of the Opt-in PLMN as its PLMN identity.

15 The signal processing functionality of the embodiments of the invention, particularly the function of the signal processor 428, may be achieved using computing systems or architectures known to those who are skilled in the relevant art. Computing systems such as, a desktop, laptop or notebook computer, hand-held computing device (PDA, cell phone, palmtop, etc.), mainframe, server, client, or any other type of special or general purpose computing device as may be desirable or
20 appropriate for a given application or environment can be used. The computing system can include one or more processors which can be implemented using a general or special-purpose processing engine such as, for example, a microprocessor, microcontroller or other control module.

The computing system can also include a main memory, such as random access memory (RAM) or other dynamic memory, for storing information and instructions to be executed by a
25 processor. Such a main memory also may be used for storing temporary variables or other intermediate information during execution of instructions to be executed by the processor. The computing system may likewise include a read only memory (ROM) or other static storage device for storing static information and instructions for a processor.

The computing system may also include an information storage system which may include, for
30 example, a media drive and a removable storage interface. The media drive may include a drive or other mechanism to support fixed or removable storage media, such as a hard disk drive, a floppy disk drive, a magnetic tape drive, an optical disk drive, a compact disc (CD) or digital video drive (DVD) read or write drive (R or RW), or other removable or fixed media drive. Storage media may include, for example, a hard disk, floppy disk, magnetic tape, optical disk, CD or DVD, or other fixed or
35 removable medium that is read by and written to by media drive. The storage media may include a computer-readable storage medium having particular computer software or data stored therein.

In alternative embodiments, an information storage system may include other similar components for allowing computer programs or other instructions or data to be loaded into the computing system. Such components may include, for example, a removable storage unit and an

interface, such as a program cartridge and cartridge interface, a removable memory (for example, a flash memory or other removable memory module) and memory slot, and other removable storage units and interfaces that allow software and data to be transferred from the removable storage unit to computing system.

5 The computing system can also include a communications interface. Such a communications interface can be used to allow software and data to be transferred between a computing system and external devices. Examples of communications interfaces can include a modem, a network interface (such as an Ethernet or other NIC card), a communications port (such as for example, a universal serial bus (USB) port), a PCMCIA slot and card, etc. Software and data transferred via a
10 communications interface are in the form of signals which can be electronic, electromagnetic, and optical or other signals capable of being received by a communications interface medium.

 In this document, the terms 'computer program product', 'computer-readable medium' and the like may be used generally to refer to tangible media such as, for example, a memory, storage device, or storage unit. These and other forms of computer-readable media may store one or more
15 instructions for use by the processor comprising the computer system to cause the processor to perform specified operations. Such instructions, generally referred to as 'computer program code' (which may be grouped in the form of computer programs or other groupings), when executed, enable the computing system to perform functions of embodiments of the present invention. Note that the code may directly cause a processor to perform specified operations, be compiled to do so, and/or be
20 combined with other software, hardware, and/or firmware elements (e.g., libraries for performing standard functions) to do so.

 In an embodiment where the elements are implemented using software, the software may be stored in a computer-readable medium and loaded into computing system using, for example, removable storage drive. A control module (in this example, software instructions or executable
25 computer program code), when executed by the processor in the computer system, causes a processor to perform the functions of the invention as described herein.

 Furthermore, the inventive concept can be applied to any circuit for performing signal processing functionality within a network element. It is further envisaged that, for example, a semiconductor manufacturer may employ the inventive concept in a design of a stand-alone device,
30 such as a microcontroller of a digital signal processor (DSP), or application-specific integrated circuit (ASIC) and/or any other sub-system element.

 It will be appreciated that, for clarity purposes, the above description has described embodiments of the invention with reference to a single processing logic. However, the inventive concept may equally be implemented by way of a plurality of different functional units and processors
35 to provide the signal processing functionality. Thus, references to specific functional units are only to be seen as references to suitable means for providing the described functionality, rather than indicative of a strict logical or physical structure or organisation.

 Aspects of the invention may be implemented in any suitable form including hardware, software, firmware or any combination of these. The invention may optionally be implemented, at

least partly, as computer software running on one or more data processors and/or digital signal processors or configurable module components such as FPGA devices. Thus, the elements and components of an embodiment of the invention may be physically, functionally and logically implemented in any suitable way. Indeed, the functionality may be implemented in a single unit, in a plurality of units or as part of other functional units.

Although the present invention has been described in connection with some embodiments, it is not intended to be limited to the specific form set forth herein. Rather, the scope of the present invention is limited only by the accompanying claims. Additionally, although a feature may appear to be described in connection with particular embodiments, one skilled in the art would recognize that various features of the described embodiments may be combined in accordance with the invention. In the claims, the term 'comprising' does not exclude the presence of other elements or steps.

Furthermore, although individually listed, a plurality of means, elements or method steps may be implemented by, for example, a single unit or processor. Additionally, although individual features may be included in different claims, these may possibly be advantageously combined, and the inclusion in different claims does not imply that a combination of features is not feasible and/or advantageous. Also, the inclusion of a feature in one category of claims does not imply a limitation to this category, but rather indicates that the feature is equally applicable to other claim categories, as appropriate.

Furthermore, the order of features in the claims does not imply any specific order in which the features must be performed and in particular the order of individual steps in a method claim does not imply that the steps must be performed in this order. Rather, the steps may be performed in any suitable order. In addition, singular references do not exclude a plurality. Thus, references to 'a', 'an', 'first', 'second', etc. do not preclude a plurality.

Claims

1. A method for at least one mobile network operator to provide selective features to at least one mobile handset, the method comprising, at a Network Operator:
 - allocating at least one public land mobile network, PLMN, identifier, ID, to at least one service offered by the at least one mobile network operator, wherein the allocated PLMN ID is distinct from said mobile network operator's normal PLMN ID; and
 - assigning the at least one PLMN ID as an Equivalent PLMN (EPLMN) ID for Opted-In mobile handsets only;the method further comprising, at the at least one base station:
 - broadcasting the at least one distinct PLMN ID; and
 - supporting provision of a range of services to the at least one mobile handset on an individual opt-in or opt-out basis based on the assigned EPLMN ID.
2. The method of Claim 1 further comprising, at a mobile handset: effecting opt-in or opt-out by sending a short message service, SMS, message to the at least one mobile network operator or via a web portal that updates an opt-in or opt-out status of the mobile handset.
3. The method of Claim 1 or Claim 2 further comprising updating an opt-in or opt-out list of allowed, assigned EPLMNs to a plurality of mobile handsets via universal subscriber identity module, USIM, updates of Equivalent HPLMN.
4. The method of Claim 1 or Claim 2 further comprising updating a list of allowed, assigned EPLMNs to a plurality of mobile handsets via at least one registration message.
5. The method of any preceding Claim wherein supporting provision of a range of services to the at least one mobile handset on an individual opt-in or opt-out basis based on the assigned EPLMN ID comprises supporting opt-in access to Core Network-based services via a Core Network connection.
6. The method of any preceding Claim wherein supporting provision of a range of services to the at least one mobile handset on an individual opt-in or opt-out basis based on the assigned EPLMN ID comprises supporting opt-in access to network-based services via a cell shared by multiple Operators.
7. The method of any of preceding Claims 1 to 5 wherein supporting provision of a range of services to the at least one mobile handset on an individual opt-in or opt-out basis based on the assigned EPLMN ID comprises supporting an opt-in access to presence services.

8. The method of Claim 7 wherein once a mobile handset has opted-in, the method further comprises, at the at least one base station:
automatically triggering for presence notification following access to the base station by the mobile handset.
9. The method of Claim 7 or Claim 8 wherein the at least one base station is coupled to a presence collector and the method further comprises, at the base station:
receiving and processing presence sightings for multiple Network Operators to obtain presence sighting information;
forwarding this information to the presence collector; and
routeing, by the presence collector, presence sighting information to the relevant Network Operator's data analytics system.
10. The method of Claim 7 or Claim 8 wherein the at least one base station comprises a presence collector and the method further comprises, at the base station:
receiving and processing presence sightings for multiple Network Operators to obtain presence sighting information; and
routeing, by the presence collector, presence sighting information to the relevant Network Operator's data analytics system.
11. The method of Claim 9 or Claim 10 wherein receiving and processing presence sightings to obtain presence sighting information comprises:
receiving a mobile handset identity; and extracting a first subset of digits of the mobile handset's identity to derive a home PLMN, HPLMN; or
using an address of a target PLMN provided by the mobile handset.
12. The method of Claim 11 further comprising, at the base station, applying an Operator-specific hash function to obscure the mobile handset identity and forwarding the hashed mobile handset identity to the at least one Network Operator.
13. The method of any of preceding Claims 11 to 12 whereby the mobile handset identity used for presence service is one from a group comprising: an International mobile subscriber identity, IMSI, temporary mobile subscriber identity, TMSI.
14. The method of any of preceding Claims 7 to 13 wherein supporting an opt-in presence server to the at least one mobile handset based on the allocated EPLMN is performed without involvement of a connection to a core network of a cellular communication system.
15. A base station supporting presence cell comprising:

a transceiver,
a signal processor operably coupled to the transceiver and configured to:
 receive a mobile handset International Mobile Subscriber Identity, IMSI, or temporary mobile subscriber identity, TMSI, or a hashed equivalent of the IMSI or TMSI;
 obtain a public land mobile network, PLMN, identity associated with the mobile handset; and
 send the hashed identity and the PLMN identity to a presence collector for relay to an appropriate Network Operator.

16. A base station for supporting a provision of selective features to mobile handsets, the base station comprising:

 a transmitter for communicating with a plurality of mobile handsets and configured to broadcast at least one allocated PLMN ID that is associated with at least one service offered by at least one mobile network operator, wherein the at least one allocated PLMN ID is distinct from a mobile network operator's normal PLMN ID; and

 a processor, operably coupled to the transmitter and configured to support provision of the at least one service to at least one mobile handset on an individual opt-in basis based on the at least one allocated PLMN ID that is assigned as an Equivalent PLMN (EPLMN) for Opted-In mobile handsets only.

17. The base station of Claim 16 wherein the base station is at least one from an evolved NodeB, eNB, a home NodeB, HNB.

18. A wireless communication system comprising at least one base station, at least one mobile handset and at least one Operator mobile network, wherein the wireless communication system is configured to provide selective features to the at least one mobile handset, wherein the Operator mobile Network is configured to:

 allocate at least one public land mobile network, PLMN, identifier, ID, to at least one service offered by the at least one mobile network operator, wherein the allocated PLMN ID is distinct from said mobile network operator's normal PLMN ID; and

 assign the at least one PLMN ID as an Equivalent PLMN (EPLMN) ID for Opted-In mobile handsets only; and

wherein the at the at least one base station is configured to:

 broadcast the at least one distinct PLMN ID; and

 support provision of a range of services to the at least one mobile handset on an individual opt-in or opt-out basis based on the assigned EPLMN ID.

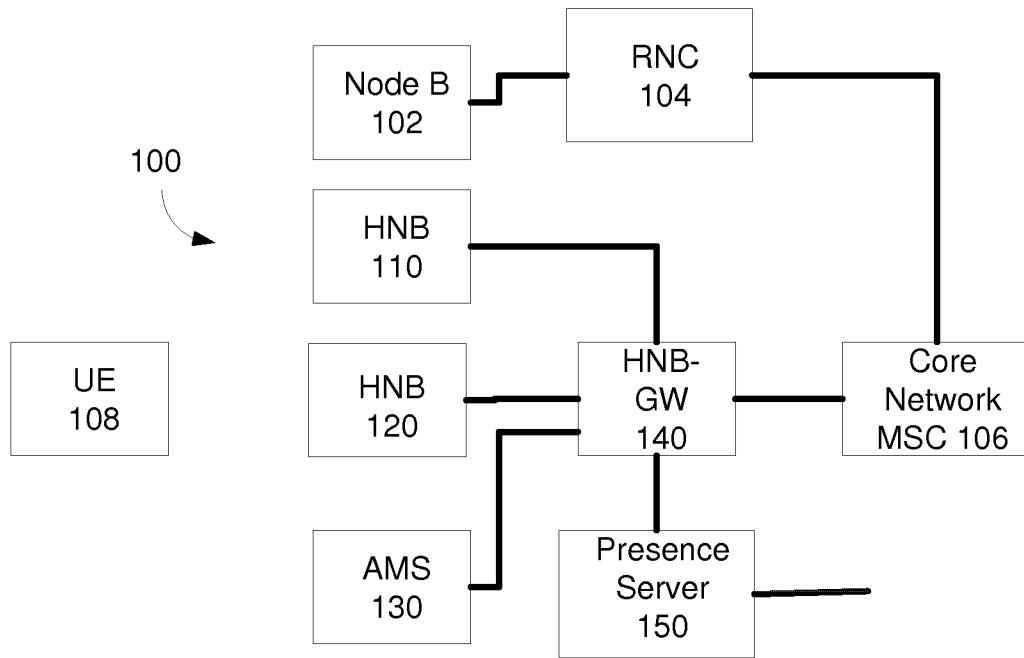

FIG. 1 – Prior art

Multi-operator
network services

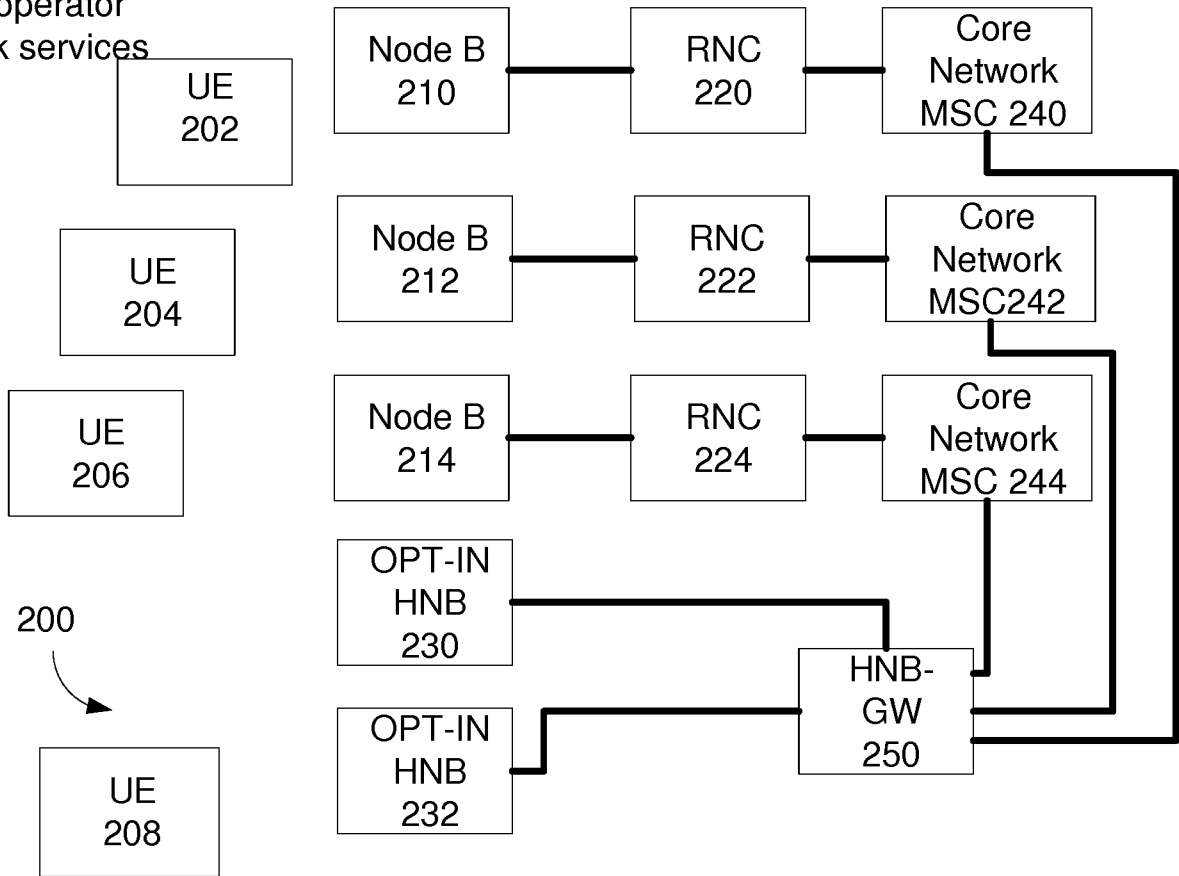

FIG. 2

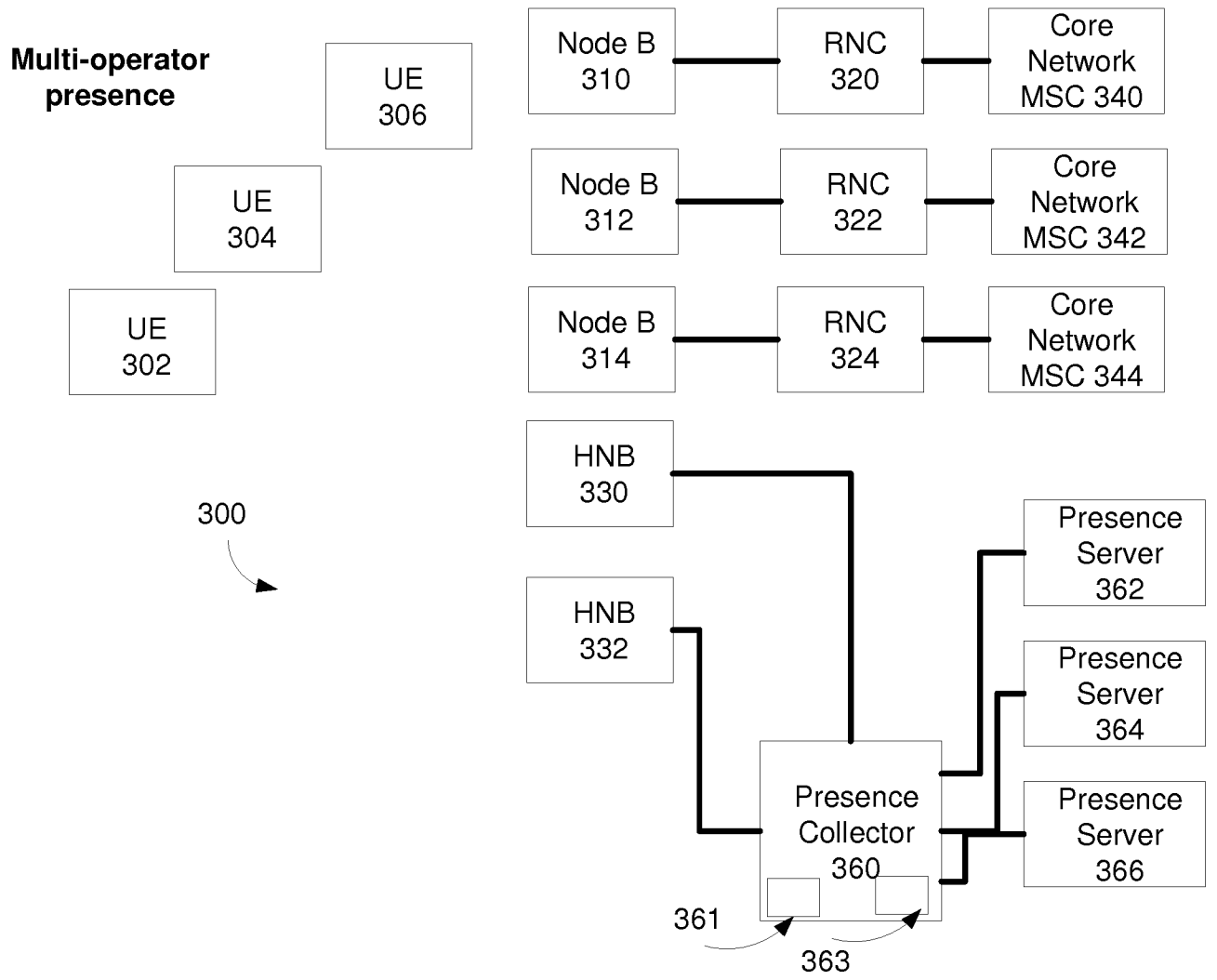

FIG. 3

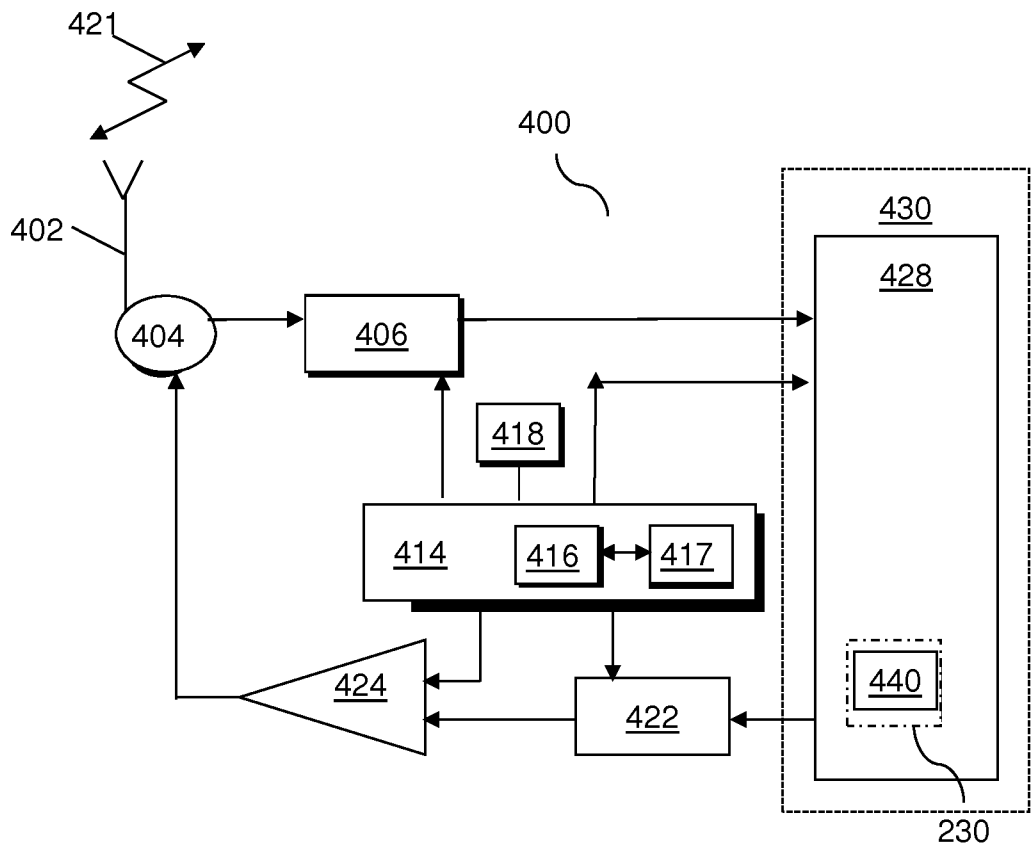
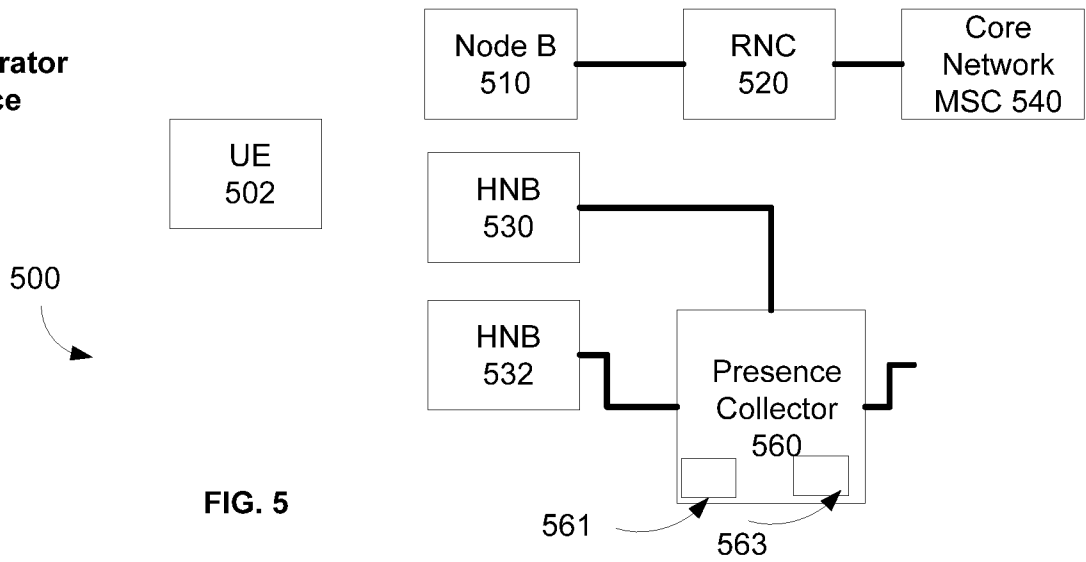
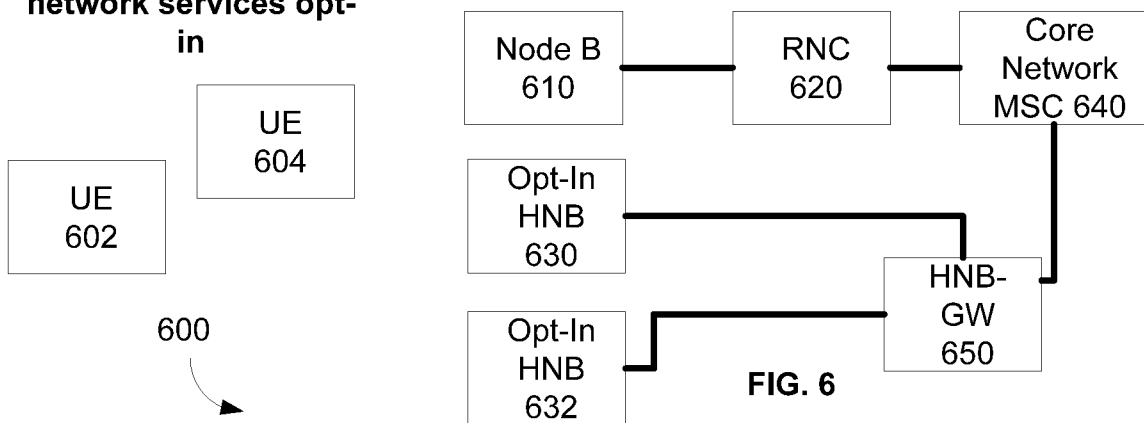

FIG. 4

Single-operator presence



Single-operator network services opt-in



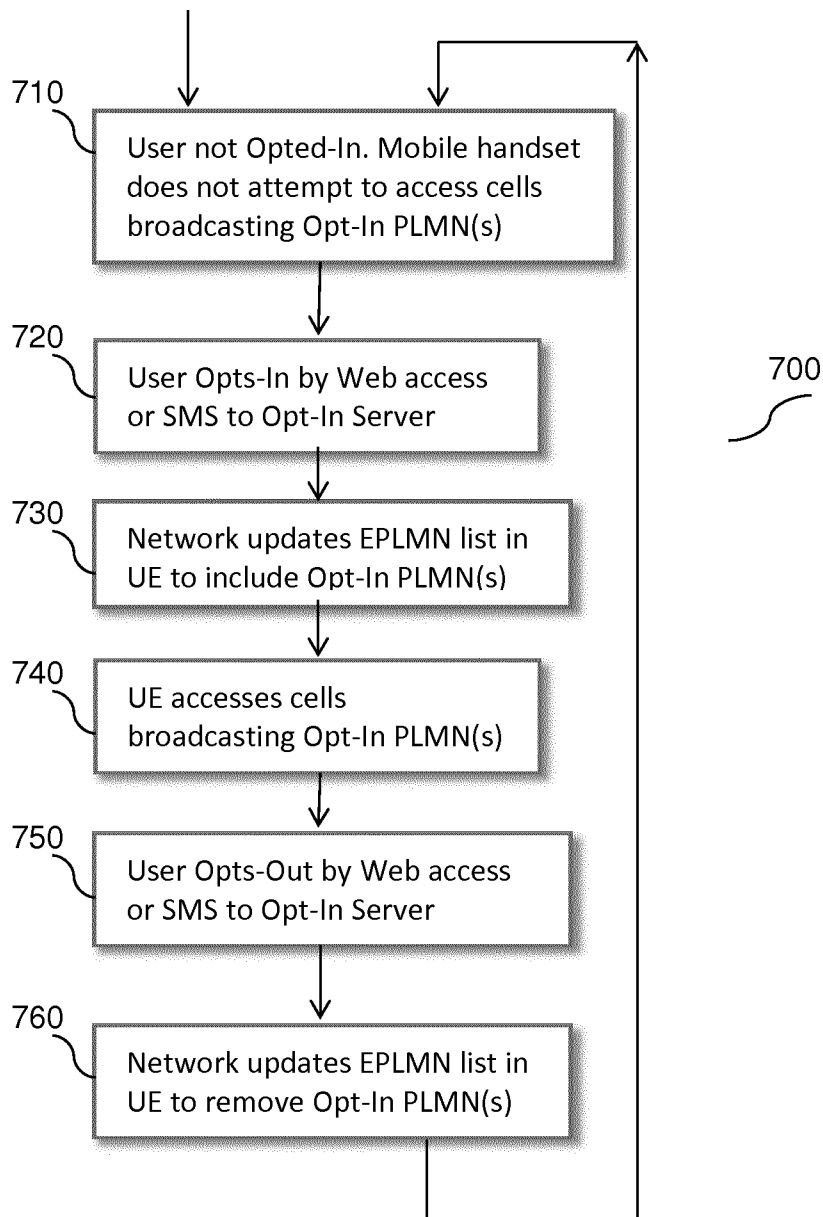
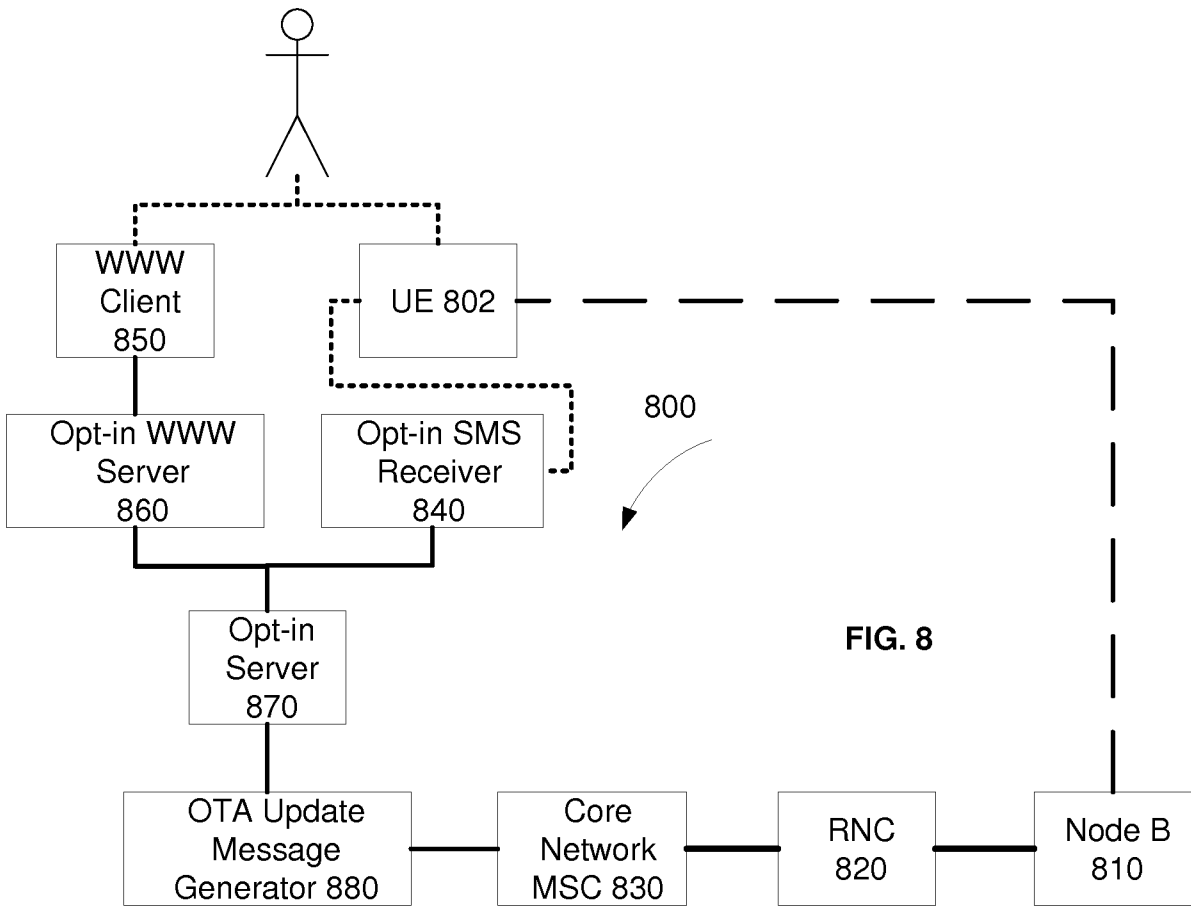

FIG. 7



INTERNATIONAL SEARCH REPORT

International application No
PCT/EP2017/059252

A. CLASSIFICATION OF SUBJECT MATTER
INV. H04W48/18 H04L29/08 G06Q30/02 H04W4/02 H04W64/00
ADD.
According to International Patent Classification (IPC) or to both national classification and IPC

B. FIELDS SEARCHED
Minimum documentation searched (classification system followed by classification symbols)
H04W H04L G06Q
Documentation searched other than minimum documentation to the extent that such documents are included in the fields searched

Electronic data base consulted during the international search (name of data base and, where practicable, search terms used)
EPO-Internal, WPI Data

C. DOCUMENTS CONSIDERED TO BE RELEVANT		
Category*	Citation of document, with indication, where appropriate, of the relevant passages	Relevant to claim No.
X Y A	US 2015/045025 A1 (LIM HAN NA [KR] ET AL) 12 February 2015 (2015-02-12) paragraph [0002] - paragraph [0007] paragraph [0010] - paragraph [0012] paragraph [0030] - paragraph [0033] paragraph [0055]	1-5, 16-18 6-14 15
X A	WO 2016/003818 A1 (INTEL IP CORP [US]) 7 January 2016 (2016-01-07) page 1, line 14 - line 16 page 4, line 1 - line 35 page 5, line 30 - line 33 page 8, line 8 - line 10 page 13, line 3 - line 6 page 17, line 4 - line 15	1-5, 16-18 6-15
	----- -/--	

Further documents are listed in the continuation of Box C.

See patent family annex.

* Special categories of cited documents :

<p>"A" document defining the general state of the art which is not considered to be of particular relevance</p> <p>"E" earlier application or patent but published on or after the international filing date</p> <p>"L" document which may throw doubts on priority claim(s) or which is cited to establish the publication date of another citation or other special reason (as specified)</p> <p>"O" document referring to an oral disclosure, use, exhibition or other means</p> <p>"P" document published prior to the international filing date but later than the priority date claimed</p>	<p>"T" later document published after the international filing date or priority date and not in conflict with the application but cited to understand the principle or theory underlying the invention</p> <p>"X" document of particular relevance; the claimed invention cannot be considered novel or cannot be considered to involve an inventive step when the document is taken alone</p> <p>"Y" document of particular relevance; the claimed invention cannot be considered to involve an inventive step when the document is combined with one or more other such documents, such combination being obvious to a person skilled in the art</p> <p>"&" document member of the same patent family</p>
---	---

Date of the actual completion of the international search 16 August 2017	Date of mailing of the international search report 22/08/2017
--	---

Name and mailing address of the ISA/ European Patent Office, P.B. 5818 Patentlaan 2 NL - 2280 HV Rijswijk Tel. (+31-70) 340-2040, Fax: (+31-70) 340-3016	Authorized officer Gutiérrez García, J
--	--

INTERNATIONAL SEARCH REPORT

International application No
PCT/EP2017/059252

C(Continuation). DOCUMENTS CONSIDERED TO BE RELEVANT		
Category*	Citation of document, with indication, where appropriate, of the relevant passages	Relevant to claim No.
Y A	US 2015/365829 A1 (GRAYSON MARK [GB] ET AL) 17 December 2015 (2015-12-17) paragraph [0024] -----	6 1-5,7-18
X Y A	US 2014/287772 A1 (SAUNDERS SIMON [GB] ET AL) 25 September 2014 (2014-09-25) paragraph [0022] - paragraph [0033] -----	15 7-14 1-6, 16-18

INTERNATIONAL SEARCH REPORT

International application No.
PCT/EP2017/059252

Box No. II Observations where certain claims were found unsearchable (Continuation of item 2 of first sheet)

This international search report has not been established in respect of certain claims under Article 17(2)(a) for the following reasons:

1. Claims Nos.:
because they relate to subject matter not required to be searched by this Authority, namely:

2. Claims Nos.:
because they relate to parts of the international application that do not comply with the prescribed requirements to such an extent that no meaningful international search can be carried out, specifically:

3. Claims Nos.:
because they are dependent claims and are not drafted in accordance with the second and third sentences of Rule 6.4(a).

Box No. III Observations where unity of invention is lacking (Continuation of item 3 of first sheet)

This International Searching Authority found multiple inventions in this international application, as follows:

see additional sheet

1. As all required additional search fees were timely paid by the applicant, this international search report covers all searchable claims.

2. As all searchable claims could be searched without effort justifying an additional fees, this Authority did not invite payment of additional fees.

3. As only some of the required additional search fees were timely paid by the applicant, this international search report covers only those claims for which fees were paid, specifically claims Nos.:

4. No required additional search fees were timely paid by the applicant. Consequently, this international search report is restricted to the invention first mentioned in the claims; it is covered by claims Nos.:

Remark on Protest

- The additional search fees were accompanied by the applicant's protest and, where applicable, the payment of a protest fee.
- The additional search fees were accompanied by the applicant's protest but the applicable protest fee was not paid within the time limit specified in the invitation.
- No protest accompanied the payment of additional search fees.

FURTHER INFORMATION CONTINUED FROM PCT/ISA/ 210

This International Searching Authority found multiple (groups of) inventions in this international application, as follows:

1. claims: 1-6, 16-18

Method, apparatus and system for providing selective service features to mobile devices in a multi-operator cell.

2. claims: 7-15

Method and apparatus for managing presence sightings of users in order to manage presence services.

INTERNATIONAL SEARCH REPORT

Information on patent family members

International application No

PCT/EP2017/059252

Patent document cited in search report	Publication date	Patent family member(s)	Publication date
US 2015045025	A1	12-02-2015	CN 104247509 A
			EP 2813105 A1
			EP 2814287 A1
			KR 20140122268 A
			KR 20150002648 A
			US 2013203418 A1
			US 2015045025 A1
			US 2015181471 A1
			US 2015382247 A1
			US 2015382248 A1
			US 2015382249 A1
			US 2015382256 A1
			US 2015382257 A1
			WO 2013119017 A1
			WO 2013119025 A1

WO 2016003818	A1	07-01-2016	CN 106465234 A
			EP 3162124 A1
			JP 2017521978 A
			KR 20170002515 A
			US 2016345243 A1
			WO 2016003818 A1

US 2015365829	A1	17-12-2015	NONE

US 2014287772	A1	25-09-2014	AU 2012213341 A1
			EP 2485546 A1
			ES 2628341 T3
			JP 6081377 B2
			JP 2014510442 A
			KR 20140045333 A
			US 2014287772 A1
			WO 2012104425 A1
