



INTERNATIONAL APPLICATION PUBLISHED UNDER THE PATENT COOPERATION TREATY (PCT)

<p>(51) International Patent Classification ⁶ : A61F 2/16</p>	<p>A1</p>	<p>(11) International Publication Number: WO 99/36003 (43) International Publication Date: 22 July 1999 (22.07.99)</p>
<p>(21) International Application Number: PCT/IL99/00004 (22) International Filing Date: 5 January 1999 (05.01.99) (30) Priority Data: 09/007,380 15 January 1998 (15.01.98) US (71) Applicant (for all designated States except US): VISIONCARE LTD. [IL/IL]; 3 Moshe Dayan Street, 56101 Yehud (IL). (72) Inventors; and (75) Inventors/Applicants (for US only): LIPSHITZ, Isaac [IL/IL]; 89a Hanasi Street, 46448 Herzelia Pituach (IL). GROSS, Yosef [IL/IL]; 205 Moshav Mazor, 73160 (IL). DOTAN, Gideon [IL/IL]; 32 Havradim Street, 56275 Yehud (IL). AHARONI, Eli [IL/IL]; 20/136 Habad Street, 75302 Rishon le Zion (IL). (74) Agents: COLB, Sanford, T. et al.; Sanford T. Colb & Co., P.O. Box 2273, 76122 Rehovot (IL).</p>		<p>(81) Designated States: AL, AM, AT, AT (Utility model), AU, AZ, BA, BB, BG, BR, BY, CA, CH, CN, CU, CZ, CZ (Utility model), DE, DE (Utility model), DK, DK (Utility model), EE, EE (Utility model), ES, FI, FI (Utility model), GB, GD, GE, GH, GM, HR, HU, ID, IL, IN, IS, JP, KE, KG, KP, KR, KZ, LC, LK, LR, LS, LT, LU, LV, MD, MG, MK, MN, MW, MX, NO, NZ, PL, PT, RO, RU, SD, SE, SG, SI, SK, SK (Utility model), SL, TJ, TM, TR, TT, UA, UG, US, UZ, VN, YU, ZW, ARIPO patent (GH, GM, KE, LS, MW, SD, SZ, UG, ZW), Eurasian patent (AM, AZ, BY, KG, KZ, MD, RU, TJ, TM), European patent (AT, BE, CH, CY, DE, DK, ES, FI, FR, GB, GR, IE, IT, LU, MC, NL, PT, SE), OAPI patent (BF, BJ, CF, CG, CI, CM, GA, GN, GW, ML, MR, NE, SN, TD, TG).</p> <p>Published <i>With international search report.</i></p>

(54) Title: INTRAOCULAR CARRYING MEMBER WITH ATTACHMENT FOR TELESCOPE

(57) Abstract

An intraocular lens implant (10, 80) including a carrying member (11), a telescope (22), and at least one mechanical fastener (82, 84) that fixedly attaches the telescope (22) to the carrying member (11). Either the carrying member (11) or the telescope (22) may be integrally formed with the at least one mechanical fastener. For example, the carrying member (11) may be formed with a female fastener (82) which mates with a corresponding male fastener (84) formed on the telescope (22). Alternatively, the carrying member (11) may be formed with a male fastener (84) which mates with a corresponding female fastener (82) formed on the telescope (22).

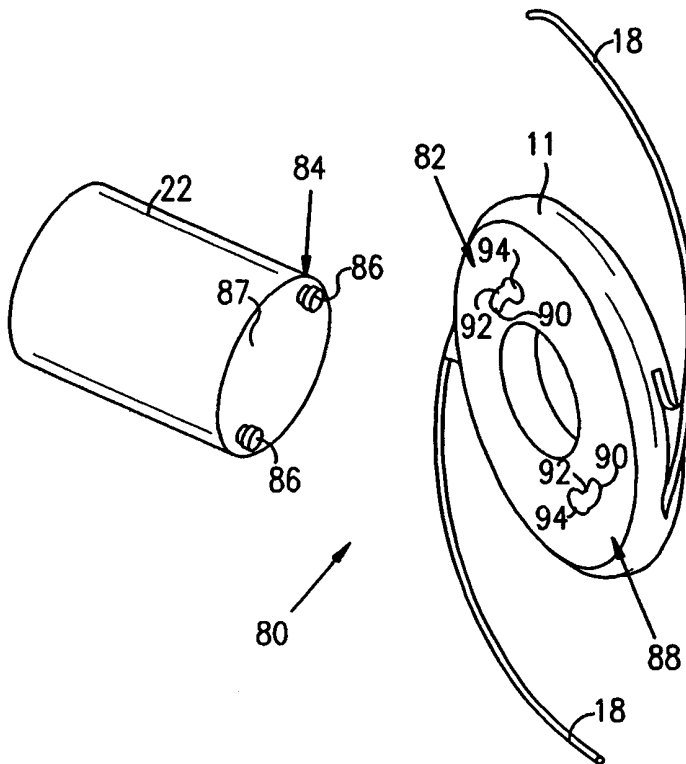

FOR THE PURPOSES OF INFORMATION ONLY

Codes used to identify States party to the PCT on the front pages of pamphlets publishing international applications under the PCT.

AL	Albania	ES	Spain	LS	Lesotho	SI	Slovenia
AM	Armenia	FI	Finland	LT	Lithuania	SK	Slovakia
AT	Austria	FR	France	LU	Luxembourg	SN	Senegal
AU	Australia	GA	Gabon	LV	Latvia	SZ	Swaziland
AZ	Azerbaijan	GB	United Kingdom	MC	Monaco	TD	Chad
BA	Bosnia and Herzegovina	GE	Georgia	MD	Republic of Moldova	TG	Togo
BB	Barbados	GH	Ghana	MG	Madagascar	TJ	Tajikistan
BE	Belgium	GN	Guinea	MK	The former Yugoslav Republic of Macedonia	TM	Turkmenistan
BF	Burkina Faso	GR	Greece	ML	Mali	TR	Turkey
BG	Bulgaria	HU	Hungary	MN	Mongolia	TT	Trinidad and Tobago
BJ	Benin	IE	Ireland	MR	Mauritania	UA	Ukraine
BR	Brazil	IL	Israel	MW	Malawi	UG	Uganda
BY	Belarus	IS	Iceland	MX	Mexico	US	United States of America
CA	Canada	IT	Italy	NE	Niger	UZ	Uzbekistan
CF	Central African Republic	JP	Japan	NL	Netherlands	VN	Viet Nam
CG	Congo	KE	Kenya	NO	Norway	YU	Yugoslavia
CH	Switzerland	KG	Kyrgyzstan	NZ	New Zealand	ZW	Zimbabwe
CI	Côte d'Ivoire	KP	Democratic People's Republic of Korea	PL	Poland		
CM	Cameroon	KR	Republic of Korea	PT	Portugal		
CN	China	KZ	Kazakstan	RO	Romania		
CU	Cuba	LC	Saint Lucia	RU	Russian Federation		
CZ	Czech Republic	LI	Liechtenstein	SD	Sudan		
DE	Germany	LK	Sri Lanka	SE	Sweden		
DK	Denmark	LR	Liberia	SG	Singapore		
EE	Estonia						

INTRAOCCULAR CARRYING MEMBER WITH ATTACHMENT FOR TELESCOPE
FIELD OF THE INVENTION

The present invention relates generally to intraocular lens (IOL) implants and particularly to an intraocular carrying member with mechanical attachments for telescopes.

5 BACKGROUND OF THE INVENTION

Intraocular inserts comprising telescopes are known. European Published Patent Application EP-A-212616 describes an intraocular lens that includes an anterior convex lens and a posterior concave lens. The contour of the lens can be selectively changed by varying the amount of fluid therein in order to change its refractive power. The lens is intended
10 solely as a replacement for the natural lens of the eye.

US Patent 4,074,368 also describes an intraocular lens that includes an anterior convex lens and a posterior concave lens with high magnification proposed for the relief of conditions such as macular degeneration and diabetic retinopathy. The lens has many relatively low power lens surfaces arranged in a relatively long lens assembly which extends, when
15 implanted, through almost the entire depth of the eye, from the pupil nearly to the retina. Implanting such a lens would necessitate major surgery. Moreover, the proposed lens does not provide a replacement for the natural lens for a wide field of view.

French Published Patent Application 2,666,735 describes an implant that includes a lens-shaped optical portion and a fastening assembly for securing the implant in the
20 eye. The optical portion includes at least one closed internal cavity which contains a fluid or vacuum, forming a refraction chamber changing the optical properties of the lens.

Applicant/assignee's US Patents 5,354,335 and 5,391,202, the disclosures of which are incorporated herein by reference, describe intraocular inserts with a positive (converging) lens facing the anterior side of the eye and a negative (diverging) lens facing the
25 posterior side, the two lenses forming a Galilean telescopic system. In US Patent 5,354,335, the lenses are assembled in a body member, the positive lens being generally flush with the anterior face of the body member. The negative lens may either be flush with the posterior face of the body member, or may project posteriorly therefrom. The body member anterior and/or posterior faces may be convex. In US Patent 5,391,202, the positive lens projects anteriorly
30 from the anterior face of the body member which is preferably a soft lens constructed from a material such as a silicone.

In US Patent Application 08/882,972, the disclosure of which is incorporated herein by reference, the present applicant/assignee discloses a further intraocular implant

comprising a telescope body having an anterior end and a posterior end and including one or more windows sealed to the telescope body at the anterior end and/or the posterior end. There are at least two lenses disposed within the telescope body intermediate the anterior and posterior ends. The lenses may be a so-called reverse Galilean telescope, i.e., a negative lens faces the anterior side of the eye while a positive lens faces the posterior side of the eye. One of the features of the system is that the lenses are doublet lenses. The windows may be formed without optical power, or alternatively, may comprise a prism.

In US Patent Application 08/882,973, the disclosure of which is incorporated herein by reference, the present applicant/assignee discloses yet another intraocular implant comprising a telescope (either Galilean or reverse Galilean) which extends through at least a portion of a lens capsule of the eye and forwardly thereof toward the anterior side of the eye, the telescope not penetrating the vitreous of the eye. The intraocular lens implant is supported within the lens capsule by loops, in the absence of a lens within the lens capsule. One of the features of the system is that the telescope may be tilted such that light from outside the eye is focused by the telescope on a low resolution but operative section of the retina. Other optional features of the system include one or more lenses having a graded index of refraction, holographic (diffusing) lenses, and/or doublet lenses which help prevent chromatic aberrations. The patent application also discloses a method for manufacturing an intraocular insert telescope employing laser fusing to join the lenses to the telescope body. Alternatively or additionally, the method employs glass particles having a low temperature melting point as a joining medium.

SUMMARY OF THE INVENTION

The present invention seeks to provide an improved telescopic lens system extending from an IOL. The present invention provides an intraocular carrying member with mechanical attachments for telescopes. In one embodiment of the present invention, the carrying member is constructed like a retaining ring for supporting a telescope. (It is noted that throughout the specification and claims the terms retaining ring and circlip are interchangeable.) The carrying member snaps onto the body of the telescope, thereby providing an inexpensive and quick method for constructing a telescoping intraocular insert. The finished assembly may be readily attached in an eye, typically in the capsular bag. Other mechanical attachments, such as threaded fasteners, snaps and studs, are also disclosed.

The present invention thus provides a novel method of constructing an intraocular implant with a telescope, either in the factory or *in situ* during implantation in the

eye. It is noted that the "carrying member" of the present invention is *not* a lens, but rather any structure suitable for implantation in the eye and which is used to support the telescope in the eye. The carrying member is illustrated herein as having the general shape of a lens. However, it is appreciated that any other shape may be used and is in the scope of the present invention.

5 There is thus provided in accordance with a preferred embodiment of the present invention an intraocular lens implant including a carrying member, a telescope, and at least one mechanical fastener that fixedly attaches the telescope to the carrying member.

 In accordance with a preferred embodiment of the present invention at least one of the carrying member and the telescope is integrally formed with the at least one mechanical
10 fastener.

 Further in accordance with a preferred embodiment of the present invention the carrying member is formed with a female fastener which mates with a corresponding male fastener formed on the telescope. Alternatively, the carrying member is formed with a male fastener which mates with a corresponding female fastener formed on the telescope. Preferably
15 the fastener of the telescope is formed at an end of the telescope.

 In accordance with a preferred embodiment of the present invention the carrying member includes a ring having a bore formed therethrough defining an inner diameter and an outer diameter, the ring being split at one point by a gap extending from the inner to the outer diameter, the ring being constructed of a material that is biocompatible for insertion into
20 a human eye, the material having sufficient resiliency so that the ring can be sprung open from an initial configuration by widening the gap upon application of a force to the ring and the ring generally returns to the initial configuration upon removal of the force, and the telescope includes a body with a perimeter shaped to receive therearound the bore of the ring, wherein the ring is attached to the telescope body by springing open the ring with the force, passing the
25 ring over the body and removing the force to allow the ring to fixedly grip the perimeter. Preferably the carrying member includes at least one haptic extending therefrom.

 Further in accordance with a preferred embodiment of the present invention the ring has a pair of holes formed in a portion of the ring intermediate the inner and outer diameters and in propinquity to the gap, one hole being on one side of the gap and the other
30 hole being on an opposite side of the gap. Preferably the perimeter is defined by an annular recess formed on the body. Additionally or alternatively, at least one annular ridge is formed on the telescope body.

In accordance with a preferred embodiment of the present invention the male fastener includes at least one stud and the female fastener is a groove formed by a first socket connected by a notch to a second socket, the notch being narrower than the sockets, wherein the at least one stud is fixedly inserted into the second socket by first inserting the at least one stud into the first socket and forcibly passing the at least one stud past the notch into the second socket.

Further in accordance with a preferred embodiment of the present invention the fasteners are threadably engageable with each other.

Still further in accordance with a preferred embodiment of the present invention the male fastener includes at least one protrusion and wherein the female fastener includes at least one tab, wherein rotation of the telescope with respect to the carrying member snugly and fixedly mates the at least one protrusion with the at least one corresponding tab.

In accordance with a preferred embodiment of the present invention the male fastener includes a flange and wherein the female fastener includes at least one elastic tongue, wherein the flange snaps together with the at least one tongue.

Further in accordance with a preferred embodiment of the present invention the at least one mechanical fastener is provided separately from the carrying member and the telescope. The telescope may include an end face which has a curvature to match a curvature of the carrying member. The telescope may include an anteriorly positioned positive lens and a posteriorly positioned negative lens. Alternatively, the telescope may include an anteriorly positioned negative lens and a posteriorly positioned positive lens.

BRIEF DESCRIPTION OF THE DRAWINGS

The present invention will be understood and appreciated more fully from the following detailed description, taken in conjunction with the drawings in which:

Fig. 1 is a simplified pictorial illustration of an intraocular carrying member implant shaped like a retaining ring, constructed and operative in accordance with a preferred embodiment of the present invention;

Fig. 2 is a simplified pictorial, exploded illustration of the intraocular carrying member implant of Fig. 1 before assembly on a telescope;

Fig. 3 is a simplified pictorial illustration of the intraocular carrying member implant of Fig. 1 assembled on the telescope in accordance with a preferred embodiment of the present invention;

Fig. 4 is a simplified pictorial illustration of a telescope with annular ridges formed thereon, constructed and operative in accordance with a preferred embodiment of the present invention;

Fig. 5 is a simplified pictorial illustration of an intraocular lens implant
5 constructed and operative in accordance with another preferred embodiment of the present invention, wherein the telescope is formed with a male thread which mates with a corresponding female thread formed on the carrying member;

Fig. 6 is a simplified pictorial illustration of an intraocular lens implant
10 constructed and operative in accordance with yet another preferred embodiment of the present invention, wherein the telescope is attached to the carrying member with separate mechanical fasteners;

Fig. 7 is a simplified pictorial illustration of an intraocular lens implant
15 constructed and operative in accordance with still another preferred embodiment of the present invention, wherein the telescope is formed with a flange which snaps together with elastic tongues formed on the carrying member;

Fig. 8 is a simplified pictorial illustration of an intraocular lens implant
constructed and operative in accordance with another preferred embodiment of the present invention, wherein the telescope has studs which mate with grooves in the carrying member;

Fig. 9 is a simplified pictorial illustration of an intraocular lens implant
20 constructed and operative in accordance with yet another preferred embodiment of the present invention, wherein the carrying member has studs which mate with grooves in the telescope;

Fig. 10 is a simplified pictorial illustration of an intraocular lens implant
constructed and operative in accordance with still another preferred embodiment of the present invention, wherein the telescope has annular protrusions which mate with tabs formed on the
25 carrying member; and

Fig. 11 is a simplified pictorial illustration of an intraocular lens implant
constructed and operative in accordance with another preferred embodiment of the present invention, wherein the telescope is bonded to the carrying member.

DETAILED DESCRIPTION OF A PREFERRED EMBODIMENT

30 Reference is now made to Fig. 1 which illustrates an intraocular carrying member implant 10 constructed and operative in accordance with a preferred embodiment of the present invention.

Lens implant 10 includes a carrying member 11 shaped in the form of a ring 12 having a bore 14 formed therethrough defining an inner diameter and an outer diameter. Bore 14 is most preferably formed through the center of ring 12. Ring 12 is split at one point by a gap 16 extending from the inner to the outer diameter. Ring 12 is constructed of a material that is biocompatible for insertion into a human eye, which material having sufficient resiliency so that ring 12 acts like a circlip. In other words, ring 12 can be sprung open from an initial configuration by widening gap 16 upon application of a force to ring 12. Ring 12 generally returns to the initial configuration upon removal of the force. A suitable material for ring 12 is polymethylmethacrylate (PMMA), for example.

Ring 12 preferably includes one or more haptics 18 extending therefrom. A pair of holes 20 are formed in a portion of ring 12 intermediate the inner and outer diameters and in propinquity to 16 gap. One hole 20 is on one side of gap 16 and the other hole 20 is on an opposite side of gap 16.

Reference is now made to Figs. 2 and 3 which illustrate assembling ring 12 on a telescope 22. Telescope 22 may be constructed in accordance with the teachings of applicant/assignee's US Patents 5,354,335 and 5,391,202, or US Patent Applications 08/882,972 or 08/882,973. As described in these references, telescope 22 may be either Galilean (having an anteriorly positioned positive lens and a posteriorly positioned negative lens) or reverse Galilean (having an anteriorly positioned negative lens and a posteriorly positioned positive lens). Telescope 22 has a body 24 with a perimeter shaped to receive therearound bore 14. As seen in Fig. 2, ring 12 may be attached to telescope body 24 by springing open ring 12 with a force generally in the direction of arrows 26 so as to widen gap 16. As is known in the art of retaining rings, a circlip tool (not shown) with nose jaws may be inserted in holes 20 to apply the force to widen gap 16. Ring 12 may then be passed over telescope body 24, whereupon the force in the direction of arrows 26 is removed to allow ring 12 to fixedly grip the perimeter of telescope body 24, as shown in Fig. 3. An annular recess 28 may be formed on telescope body 24 for receiving therein ring 12.

Alternatively, as seen in Fig. 4, one or more annular ridges 30 may be formed on telescope body 24 and ring 12 may be passed over telescope body 24 to firmly sit between ridges 30.

Reference is now made to Fig. 5 which illustrates an intraocular lens implant 50 constructed and operative in accordance with another preferred embodiment of the present invention. In lens implant 50, telescope 22 is formed with a male thread 52 which mates with a

corresponding female thread 54 formed on carrying member 11. Of course, alternatively, the female thread could be formed on the telescope and the male thread on the carrying member.

Reference is now made to Fig. 6 which illustrates an intraocular lens implant 60 constructed and operative in accordance with yet another preferred embodiment of the present invention. In lens implant 60, telescope 22 is attached to carrying member 11 with separate mechanical fasteners 62, such as screws. For purposes of example only, fasteners 62 may fit through holes 64 formed in a flange 66 of telescope 22 and mate with threaded holes 68 formed in carrying member 11. It is seen in Fig. 6 that telescope 22 may include an end face which has a curvature (e.g., concavity) to match a curvature of carrying member 11 (e.g., convexity). This feature, of course, may be provided in any of the other intraocular lens implants of the present invention.

Reference is now made to Fig. 7 which illustrates an intraocular lens implant 70 constructed and operative in accordance with still another preferred embodiment of the present invention. In lens implant 70, telescope 22 is formed with a flange 72 which snaps together with one or more elastic tongues 74 formed on carrying member 11. Of course, alternatively, the tongues could be formed on the telescope and the flange on the carrying member.

Reference is now made to Fig. 8 which illustrates an intraocular lens implant 80 constructed and operative in accordance with another preferred embodiment of the present invention. In lens implant 80, carrying member 11 is formed with one or more female fasteners 82 and telescope 22 is formed with one or more corresponding male fasteners 84.

Male fastener 84 preferably includes one or more studs 86 protruding from an end 87 of telescope 22, and female fastener 82 includes one or more grooves 88 corresponding to studs 86. Each groove 88 is preferably formed by a first socket 90 connected by a notch 92 to a second socket 94. Notch 92 is preferably narrower than sockets 90 and 94 so that each stud 86 may be inserted into first socket 90, and then fixedly seated in second socket 94 by turning telescope 22 so as to forcibly pass stud 86 past notch 92. The outer dimension of stud 86, in the case of a cylindrical stud the diameter, and the material of stud are selected so that stud 86 is preferably slightly compressed as it passes through notch 92. A suitable material for stud 86, as well as for the rest of lens implant 80, is polymethylmethacrylate (PMMA), for example.

Reference is now made to Fig. 9 which illustrates an intraocular lens implant 96 constructed and operative in accordance with still another preferred embodiment of the present invention. Lens implant 96 is basically the same as lens implant 80 except that carrying member

11 is formed with male fasteners 84 which mate with the corresponding female fasteners 82 formed on telescope 22.

Reference is now made to Fig. 10 which illustrates an intraocular lens implant 100 constructed and operative in accordance with yet another preferred embodiment of the present invention. In lens implant 100, telescope 22 is formed with one or more annular protrusions 102 which snugly and fixedly mate with one or more tabs 104 formed on carrying member 11. Protrusions 102, preferably formed at an end of telescope 22, are forcibly slid under tabs 104 by suitably rotating telescope 22 and carrying member 11 with respect to each other. Protrusions 102 thus act as male fasteners and tabs 104 act as female fasteners. Of course, alternatively, the tabs could be formed on the telescope and the protrusions on the carrying member.

Reference is now made to Fig. 11 which illustrates an intraocular lens implant 106 constructed and operative in accordance with still another preferred embodiment of the present invention. In lens implant 106, telescope 22 is bonded to carrying member 11, such as by means of a biocompatible adhesive 108.

It will be appreciated by persons skilled in the art that the present invention is not limited by what has been particularly shown and described hereinabove. Rather the scope of the present invention includes both combinations and subcombinations of the features described hereinabove as well as modifications and variations thereof which would occur to a person of skill in the art upon reading the foregoing description and which are not in the prior art.

C L A I M S

What is claimed is:

1. An intraocular lens implant (10, 80) comprising a carrying member (11), a telescope (22), and at least one mechanical fastener (12, 52, 54, 82, 84) that fixedly attaches
5 said telescope (22) to said carrying member (11).
2. The implant (10, 80) according to claim 1 wherein at least one of said carrying member (11) and said telescope (22) is integrally formed with said at least one mechanical fastener (12, 52, 54, 82, 84).
3. The implant (10, 80) according to claim 1 wherein said carrying member (11) is
10 formed with a female fastener (54, 82) which mates with a corresponding male fastener (52, 84) formed on said telescope (22).
4. The implant (80) according to claim 1 wherein said carrying member (11) is formed with a male fastener (84) which mates with a corresponding female fastener (82) formed on said telescope (22).
- 15 5. The implant (80) according to claim 1 and wherein said fastener (82, 84) of said telescope (22) is formed at an end (87) of said telescope (22).
6. The implant (10) according to claim 1 wherein said carrying member (11) comprises:
a ring (12) having a bore (14) formed therethrough defining an inner diameter
20 and an outer diameter, said ring (12) being split at one point by a gap (16) extending from the inner to the outer diameter, said ring (12) being constructed of a material that is biocompatible for insertion into a human eye, said material having sufficient resiliency so that said ring (12) can be sprung open from an initial configuration by widening said gap (16) upon application of a force to said ring (12) and said ring (12) generally returns to said initial configuration upon
25 removal of said force; and
said telescope (22) comprises a body (24) with a perimeter shaped to receive therearound said bore (14) of said ring (12), wherein said ring (12) is attached to said telescope body (24) by springing open said ring (12) with said force, passing said ring (12) over said body (24) and removing said force to allow said ring (12) to fixedly grip said
30 perimeter.
7. The implant (10) according to claim 1 wherein said carrying member (11) comprises at least one haptic (18) extending therefrom.

8. The implant (10) according to claim 6 or claim 7 wherein said ring (12) has a pair of holes (20) formed in a portion of said ring (12) intermediate the inner and outer diameters and in propinquity to said gap (16), one hole (20) being on one side of said gap (16) and the other hole (20) being on an opposite side of said gap (16).
- 5 9. The implant (10) according to claim 8 and wherein said perimeter is defined by an annular recess (28) formed on said body (24).
10. The implant (10) according to claim 8 and wherein at least one annular ridge (30) is formed on said telescope body (24).
11. The implant (80) according to claim 3 or claim 4 and wherein said male fastener (84) comprises at least one stud (86) and said female fastener (82) is a groove (88) formed by a first socket (90) connected by a notch (92) to a second socket (94), said notch (92) being narrower than said sockets (90, 94), wherein said at least one stud (86) is fixedly inserted into said second socket (94) by first inserting said at least one stud (86) into said first socket (90) and forcibly passing said at least one stud (86) past said notch (92) into said second socket (94).
- 15 12. The implant (10) according to claim 3 or claim 4 and wherein said fasteners (52, 54) are threadably engageable with each other.
13. The implant (100) according to claim 3 or claim 4 and wherein said male fastener comprises at least one protrusion (102) and wherein said female fastener comprises at least one tab (104), wherein rotation of said telescope (22) with respect to said carrying member (11) snugly and fixedly mates said at least one protrusion (102) with said at least one corresponding tab (104).
- 20 14. The implant (70) according to claim 3 or claim 4 and wherein said male fastener comprises a flange (72) and wherein said female fastener comprises at least one elastic tongue (74), wherein said flange (72) snaps together with said at least one tongue (74).
- 25 15. The implant (60) according to claim 1 wherein said at least one mechanical fastener (62) is provided separately from said carrying member (11) and said telescope (22).
16. The implant (60) according to claim 1 and wherein said telescope (22) comprises an end face which has a curvature to match a curvature of said carrying member (11).
- 30 17. The implant (106) according to claim 1 and wherein said telescope (22) is bonded to said carrying member (11).

18. The implant (10) according to claim 1 and wherein said telescope (22) comprises an anteriorly positioned positive lens and a posteriorly positioned negative lens.

19. The implant (10) according to claim 1 and wherein said telescope (22) comprises an anteriorly positioned negative lens and a posteriorly positioned positive lens.

FIG. 1

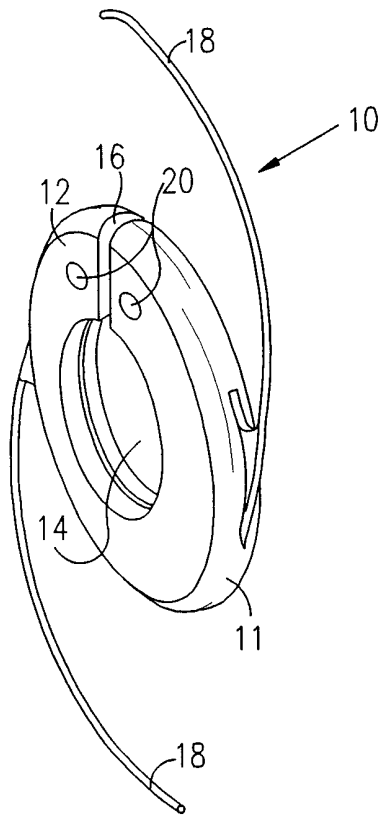

FIG. 2

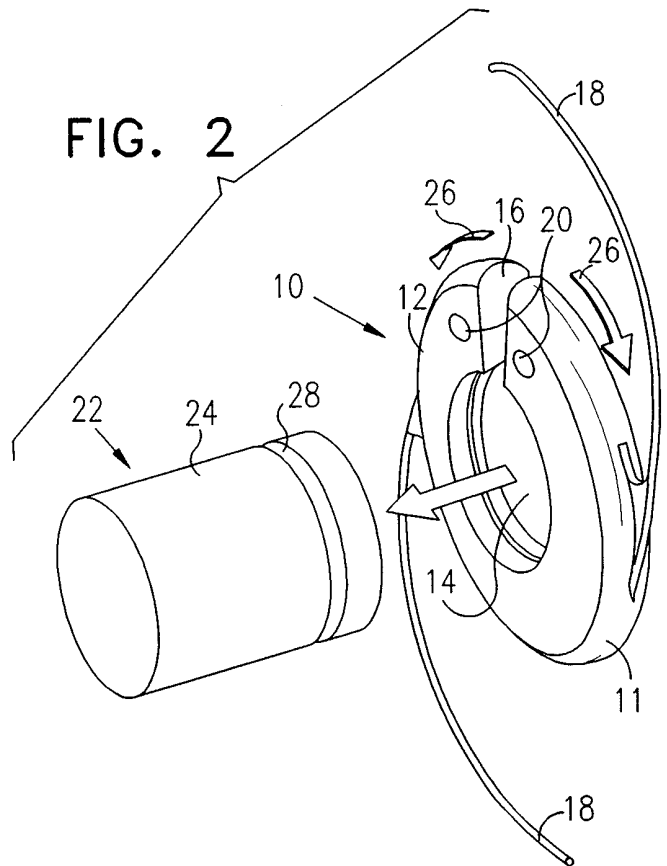

FIG. 3

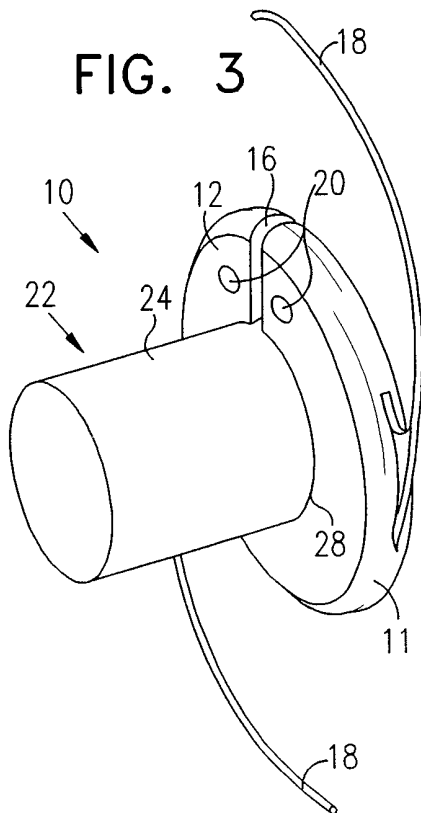
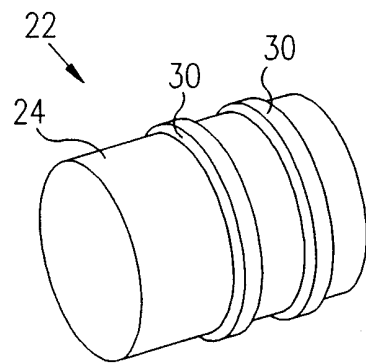

FIG. 4



2/4

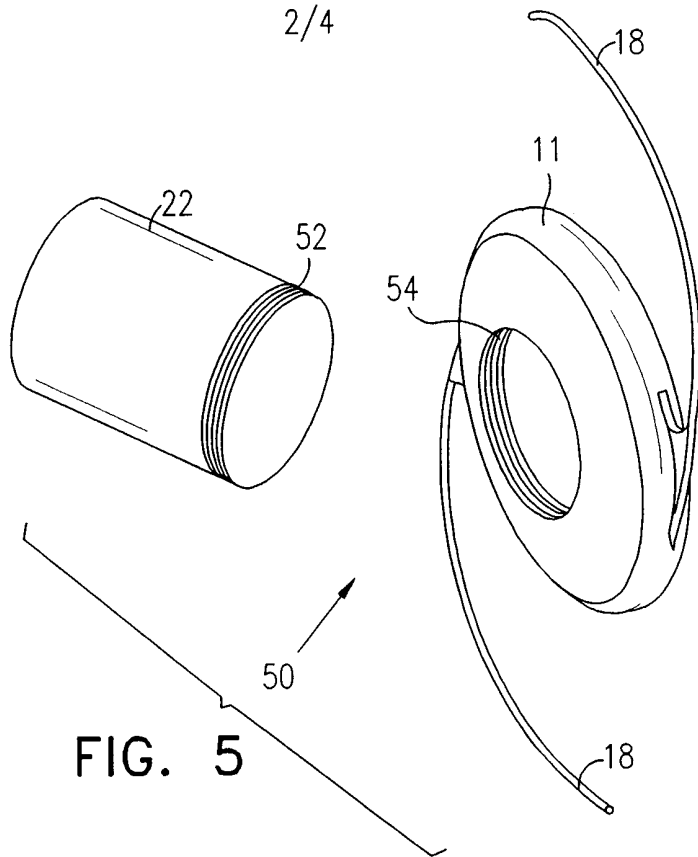

FIG. 5

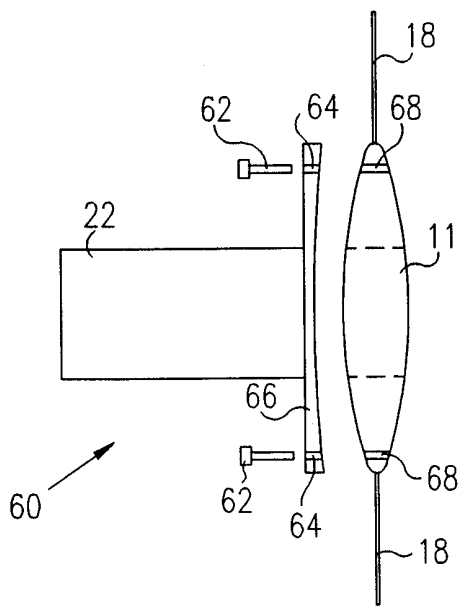

FIG. 6

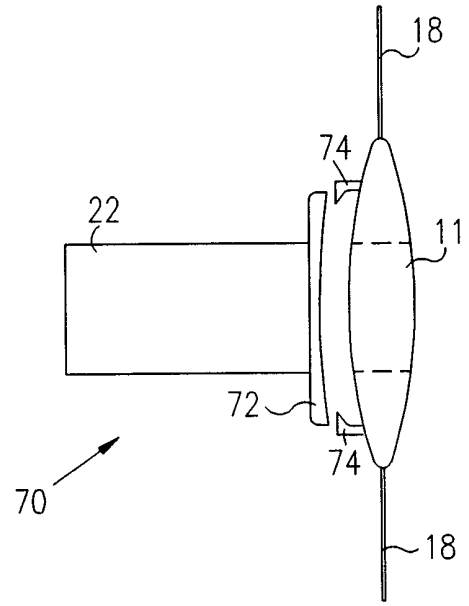
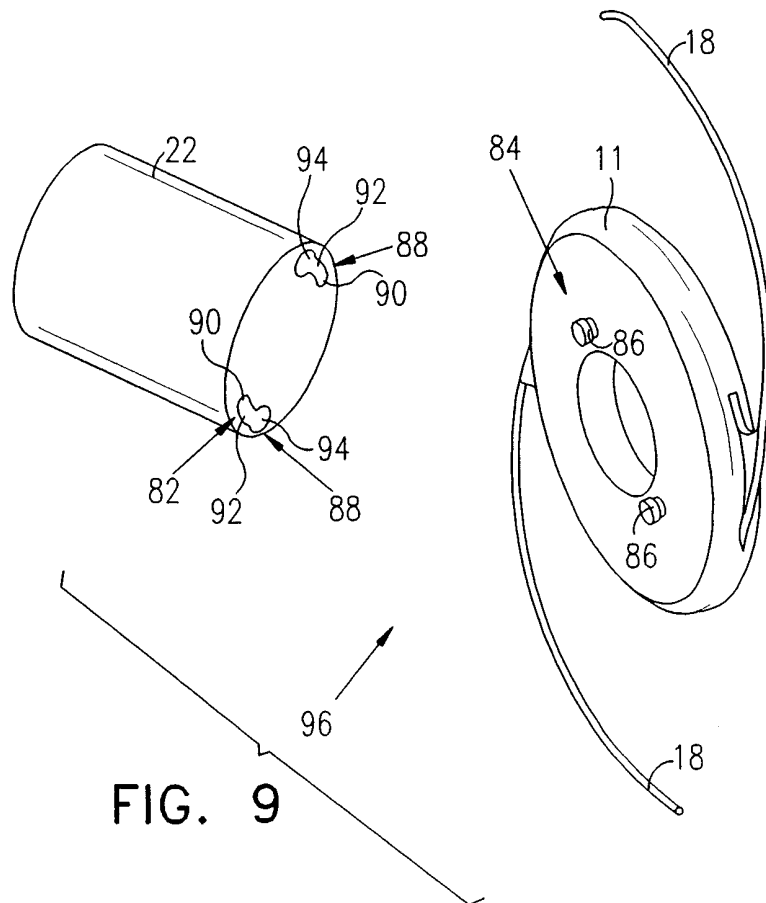
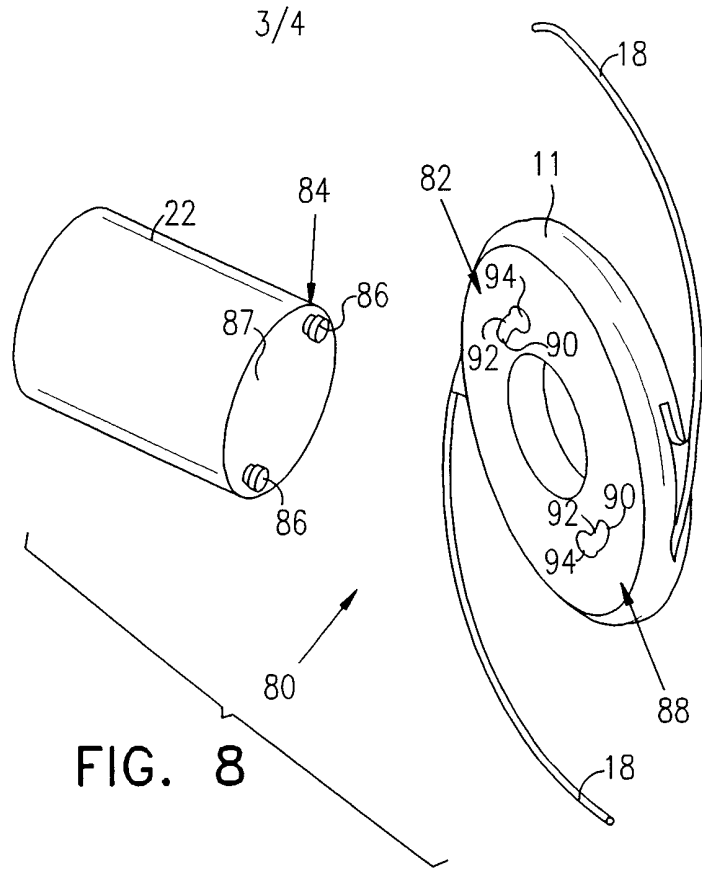

FIG. 7



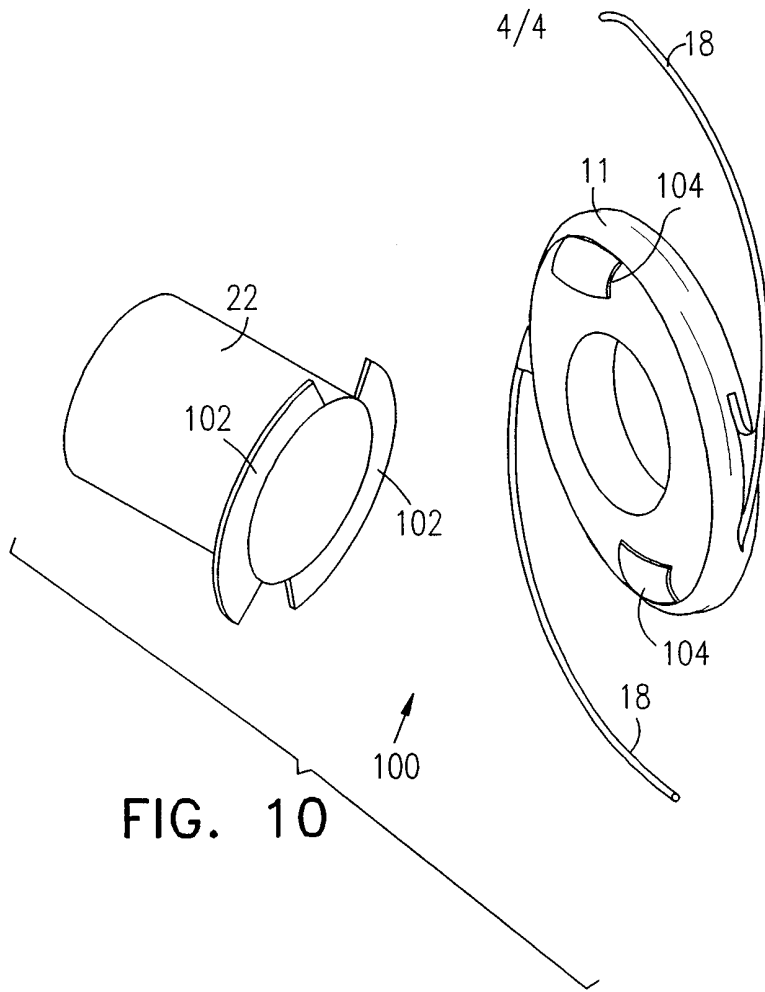
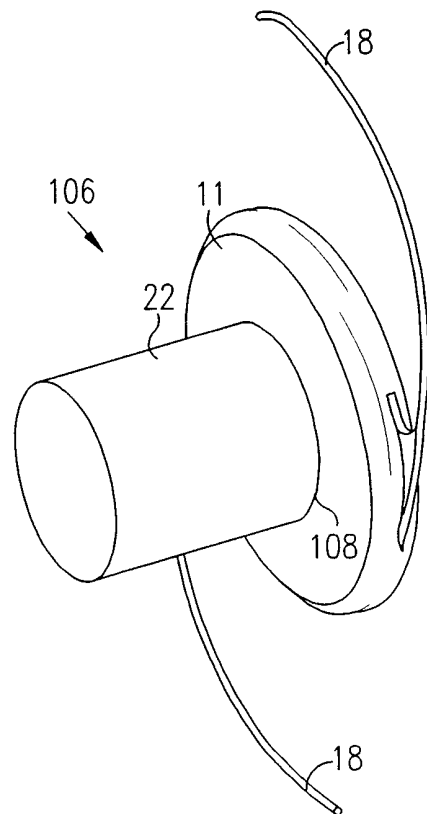

FIG. 10

FIG. 11



INTERNATIONAL SEARCH REPORT

International Application No

PCT/IL 99/00004

A. CLASSIFICATION OF SUBJECT MATTER
IPC 6 A61F2/16

According to International Patent Classification (IPC) or to both national classification and IPC

B. FIELDS SEARCHED

Minimum documentation searched (classification system followed by classification symbols)

IPC 6 A61F

Documentation searched other than minimum documentation to the extent that such documents are included in the fields searched

Electronic data base consulted during the international search (name of data base and, where practical, search terms used)

C. DOCUMENTS CONSIDERED TO BE RELEVANT

Category °	Citation of document, with indication, where appropriate, of the relevant passages	Relevant to claim No.
Y A	US 4 994 082 A (W.D. RICHARDS ET AL.) 19 February 1991 see column 3, line 41 - line 47; figures 1,2 see column 8, line 35 - line 50; figures 5,6	1-5,7, 12-19 9,10
Y	--- US 5 391 202 A (I. LIPSHITZ ET AL.) 21 February 1995 cited in the application see the whole document	1-5,7, 12-19
Y A	--- US 5 628 798 A (H.C. EGGLESTON ET AL.) 13 May 1997 see abstract; figures	12,13 6
	--- -/--	

Further documents are listed in the continuation of box C.

Patent family members are listed in annex.

° Special categories of cited documents :

"A" document defining the general state of the art which is not considered to be of particular relevance

"E" earlier document but published on or after the international filing date

"L" document which may throw doubts on priority claim(s) or which is cited to establish the publication date of another citation or other special reason (as specified)

"O" document referring to an oral disclosure, use, exhibition or other means

"P" document published prior to the international filing date but later than the priority date claimed

"T" later document published after the international filing date or priority date and not in conflict with the application but cited to understand the principle or theory underlying the invention

"X" document of particular relevance; the claimed invention cannot be considered novel or cannot be considered to involve an inventive step when the document is taken alone

"Y" document of particular relevance; the claimed invention cannot be considered to involve an inventive step when the document is combined with one or more other such documents, such combination being obvious to a person skilled in the art.

"&" document member of the same patent family

Date of the actual completion of the international search

27 April 1999

Date of mailing of the international search report

06/05/1999

Name and mailing address of the ISA

European Patent Office, P.B. 5818 Patentlaan 2
NL - 2280 HV Rijswijk
Tel. (+31-70) 340-2040, Tx. 31 651 epo nl,
Fax: (+31-70) 340-3016

Authorized officer

Wolf, C

INTERNATIONAL SEARCH REPORT

International Application No

PCT/IL 99/00004

C.(Continuation) DOCUMENTS CONSIDERED TO BE RELEVANT

Category *	Citation of document, with indication, where appropriate, of the relevant passages	Relevant to claim No.
Y	WO 94 07435 A (NESTLE S.A.) 14 April 1994 see page 12, line 30 - page 13, line 2; figures 25-27 ---	14,16
Y	US 5 222 981 A (T.P. WERBLIN) 29 June 1993 see column 3, line 30 - line 36; figures 2A-2C ---	15
Y	EP 0 212 616 A (KINGSTON TECHNOLOGIES) 4 March 1987 cited in the application see figure 6 ---	19
A	DE 44 03 326 C (H.R. KOCH) 22 June 1995 -----	

INTERNATIONAL SEARCH REPORT

Information on patent family members

Int tional Application No
PCT/IL 99/00004

Patent document cited in search report	A	Publication date	Patent family member(s)	Publication date
US 4994082	A	19-02-1991	NONE	
US 5391202	A	21-02-1995	US 5354335 A	11-10-1994
			AU 6125894 A	29-08-1994
			CA 2155428 A	18-08-1994
			EP 0682506 A	22-11-1995
			WO 9417756 A	18-08-1994
US 5628798	A	13-05-1997	US 5800533 A	01-09-1998
WO 9407435	A	14-04-1994	AU 5127393 A	26-04-1994
			CA 2145990 A	14-04-1994
			EP 0662808 A	19-07-1995
			JP 8501715 T	27-02-1996
			US 5358520 A	25-10-1994
			US 5366502 A	22-11-1994
US 5222981	A	29-06-1993	DE 69215600 D	16-01-1997
			DE 69215600 T	24-04-1997
			EP 0528325 A	24-02-1993
			JP 7178126 A	18-07-1995
EP 212616	A	04-03-1987	US 4731078 A	15-03-1988
			JP 62079054 A	11-04-1987
DE 4403326	C	22-06-1995	AU 1574695 A	21-08-1995
			WO 9520926 A	10-08-1995
			DE 59502105 D	10-06-1998
			EP 0742702 A	20-11-1996
			US 5824074 A	20-10-1998