



(43) International Publication Date  
19 June 2014 (19.06.2014)

(51) International Patent Classification:

F23D 1/00 (2006.01) F23D 14/22 (2006.01)  
F23D 1/02 (2006.01) F23D 14/24 (2006.01)

(21) International Application Number:

PCT/US2013/074115

(22) International Filing Date:

10 December 2013 (10.12.2013)

(25) Filing Language:

English

(26) Publication Language:

English

(30) Priority Data:

13/709,939 10 December 2012 (10.12.2012) US

(71) Applicant: **ZILKHA BIOMASS POWER I LLC**  
[US/US]; 1001 McKinney, Suite 1925, Houston, TX  
77002 (US).

(72) Inventor: **FORSBERG, Lars Bjorn**; Balinge Tybble Mel-  
langarden 1, SE-611 99 Tystberga (SE).

(74) Agent: **SMITH, Michael, H.**; Hall Estill Law Firm, 100  
North Broadway, Suite 2900, Oklahoma City, OK 73102  
(US).

(81) Designated States (unless otherwise indicated, for every kind of national protection available): AE, AG, AL, AM, AO, AT, AU, AZ, BA, BB, BG, BH, BN, BR, BW, BY, BZ, CA, CH, CL, CN, CO, CR, CU, CZ, DE, DK, DM, DO, DZ, EC, EE, EG, ES, FI, GB, GD, GE, GH, GM, GT, HN, HR, HU, ID, IL, IN, IR, IS, JP, KE, KG, KN, KP, KR, KZ, LA, LC, LK, LR, LS, LT, LU, LY, MA, MD, ME, MG, MK, MN, MW, MX, MY, MZ, NA, NG, NI, NO, NZ, OM, PA, PE, PG, PH, PL, PT, QA, RO, RS, RU, RW, SA, SC, SD, SE, SG, SK, SL, SM, ST, SV, SY, TH, TJ, TM, TN, TR, TT, TZ, UA, UG, US, UZ, VC, VN, ZA, ZM, ZW.

(84) Designated States (unless otherwise indicated, for every kind of regional protection available): ARIPO (BW, GH, GM, KE, LR, LS, MW, MZ, NA, RW, SD, SL, SZ, TZ, UG, ZM, ZW), Eurasian (AM, AZ, BY, KG, KZ, RU, TJ, TM), European (AL, AT, BE, BG, CH, CY, CZ, DE, DK, EE, ES, FI, FR, GB, GR, HR, HU, IE, IS, IT, LT, LU, LV, MC, MK, MT, NL, NO, PL, PT, RO, RS, SE, SI, SK, SM, TR), OAPI (BF, BJ, CF, CG, CI, CM, GA, GN, GQ, GW, KM, ML, MR, NE, SN, TD, TG).

Published:

— with international search report (Art. 21(3))

(54) Title: COMBUSTOR ASSEMBLY AND METHODS OF USING SAME

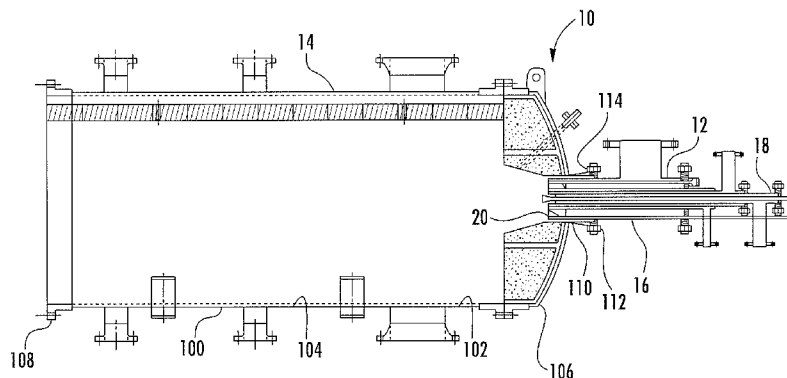

FIG. 1

(57) Abstract: One embodiment of the present disclosure relates to a combustor assembly which has a burner assembly and a combustor. The burner assembly has a body having a first end and a second end and a center passageway. The center passageway extends between the first end and the second end of the body. The body of the burner assembly is provided with a biomass inlet for receiving biomass, a primary air inlet for receiving air, a gas inlet for receiving gas, and a secondary air inlet for receiving air. The biomass inlet is in communication with the center passageway.

WO 2014/093336 A1

# **COMBUSTOR ASSEMBLY AND METHODS OF USING SAME**

## **FIELD OF THE INVENTION**

**[0001]** One embodiment of the present disclosure relates generally to a combustor assembly, more particularly, but not by way of limitation, to an improved combustor assembly and method for improving slagging in a combustor.

## **BACKGROUND OF THE INVENTION**

**[0002]** Many power systems have a combustor which is operated by the controlled combustion of various solid fuel sources or feedstocks to generate electricity by driving gas turbines. Examples of solid fuel sources utilized in the systems are conventional fossil fuels, other hydrocarbons, and biomass. Examples of biomass include, but are not limited to sawdust, bark, twigs, branches, and other waste wood, bagasse, corn cobs, rice hulls, orchard and vine trimmings, and the like. However, typically, combustion of these fuels is incomplete, producing large amounts of waste material.

**[0003]** All solid fuels contain a mineral fraction that is mostly non-combustible and produces waste material, such as ash. Incomplete combustion of biomass produces ash that accumulates on a heat transfer or interior surface of a combustor. As molten ash cools, the ash accumulates on the interior surfaces of the combustion chamber causing various problems with the operation of the combustor and the power system. Deposit of formations of ash ("slagging") is one of the biggest

problems of combustion of biomass. The ability of a system to reduce/improve slagging would lead to reduced investment and operational costs, increased performance efficiency, and reduced emissions.

**[0004]** To this end, although combustor assemblies are known in the art, further improvements are desirable to improve or reduce slagging in the combustor and to enhance the combustor assembly for complete combustion of a fuel source. It is to such an assembly and process that one embodiment of the present disclosure is directed.

### **SUMMARY OF THE INVENTION**

**[0005]** A burner assembly includes a body, a biomass inlet, a primary air inlet, a gas inlet, and a secondary inlet. The body has a first end, an open second end, and a center passageway extending therebetween. The biomass inlet receives biomass such that the biomass inlet is in communication with the center passageway so that biomass is injected from the center passageway by the open second end along a tangential centerline of the body. The primary air inlet receives primary air. The gas inlet receives a gas. The secondary air inlet receives secondary air.

**[0006]** A combustor assembly includes a burner assembly and a combustor. A burner assembly includes a body, a biomass inlet, a primary air inlet, a gas inlet, and a secondary inlet. The body has a first end, an open second end, and a center passageway extending therebetween. The biomass inlet receives biomass such that the biomass inlet is in communication with the center passageway so that biomass is

injected from the center passageway by the open second end along a tangential centerline of the body. The primary air inlet receives primary air. The gas inlet receives a gas. The secondary air inlet receives secondary air. The burner assembly is connected to a combustor.

**[0007]** A method of operating a combustor assembly. Biomass feed material is injected into a center passageway of a body of a burner assembly. Primary air, gas, and secondary air are injected into the body of the burner assembly. The biomass feed material is injected along a tangential centerline of the body of the burner assembly into a combustor.

#### **BRIEF DESCRIPTION OF THE SEVERAL VIEWS OF THE DRAWINGS**

**[0008]** FIG. 1 is a cross-sectional view of a combustor assembly constructed in accordance with the present invention.

**[0009]** FIG. 2 is a cross-sectional view of a burner assembly of the combustor assembly of FIG. 1.

**[0010]** FIG. 3 is a front view of a second end of the burner assembly of FIG. 2.

**[0011]** FIG. 4 is a cross-sectional view of a portion of a combustor of the combustor assembly of FIG. 1.

#### **DETAILED DESCRIPTION OF THE INVENTION**

**[0012]** Referring now to the drawings, and more particularly to FIG. 1, shown therein is one embodiment of a combustor assembly 10 constructed in accordance with the present disclosure. The combustor

assembly 10 includes a burner assembly 12 and a combustor 14. It should be understood by one of ordinary skill in the art that the combustor assembly 10 may be utilized in a system having a feed system and a gas turbine. The feed system may be any such system for feeding biomass into a system known to one of ordinary skill in the art so long as the feed system functions in accordance with the present invention. Further, the gas turbine may be any suitable gas turbine known by one of ordinary skill in the art. For example, the gas turbine may be a gas-fired turbine. Also, the gas turbine may have any of a variety of pressure ratios, for example, gas turbines suitable for use may have pressure ratios in the range of from about 4:1 to about 20:1. Furthermore, the gas turbine may be capable of dual firing, wherein the gas turbine may be fired using an auxiliary fuel, for example, gas, propane, or a liquid fuel.

**[0013]** Referring now to FIGS. 1-3, generally, one embodiment of the burner assembly 12 includes a body 16 having a first end 18, a second end 20, a biomass inlet 22, a primary air inlet 24, a gas inlet 26, and a secondary air inlet 28 and a powder cone assembly 30. The body 16 may be any size and shape so long as the body 16 functions in accordance with the present disclosure. The biomass inlet 22 is provided for receiving biomass from a feed system (not shown). Biomass may include any suitable source of biomass, including, sawdust, bark, twigs, branches, other waste wood, bagasse, corn cobs, rice hulls, orchard and vine trimmings, sludge, manure, and combinations thereof. In one embodiment, the biomass supplied to the combustor assembly 10

includes a wood-based biomass. The biomass supplied to the combustor assembly 10 may be sized so that it has a major dimension of less than about 3 millimeters ("mm"). Further, the biomass also may have moisture content suitable for combustion, for example, the biomass may be dried so that they have a moisture content of less than about 30% and, in one embodiment, a moisture content in the range of from about 0% to about 20%. Those of ordinary skill in the art should recognize that combustion generally may have various feed requirements (e.g., size, moisture content, etc.). Further, it should be understood by one of ordinary skill in the art that although biomass is used, by way of example, as the fuel source for the combustor assembly 10, any known fuel source may be utilized, such as fossil fuels and the like, so long as the fuel used allows the combustor assembly 10 to function in accordance with the present disclosure as described herein.

**[0014]** Biomass is fed through the biomass inlet 22 to the biomass intake tube 32 which is in communication with a substantially center passageway 34 extending between the first end 18 and the second end 20 of the body 16 of the burner assembly 12. The position and configuration of the center passageway 34 of the burner assembly 12 allows for centerline tangential injection of the biomass feed into the combustor 14. Centerline injection of the feed into the combustor 14 keeps ash off an interior surface of the combustor 14 which improves slagging in the combustor 14.

**[0015]** Primary air is provided to the body 16 through the primary air inlet 24 to the primary air intake tube 40 which is in communication with a primary air tube 42. The primary air tube 42 is in communication with a primary air register 44.

**[0016]** Gas, such as propane, butane, propane-butane mix, methane, and the like, is provided to the body 16 through the gas inlet 26 to the gas intake tube 50 which is in communication with a gas tube 52. The gas tube 52 is in communication with a gas ring 54.

**[0017]** Secondary air is fed to the body 16 through the secondary air inlet 28 to the secondary air intake tube 60 which is in communication with a secondary air tube 62. The secondary air tube 62 is in communication with a secondary air register 64. It should be understood by one of ordinary skill in the art that the primary air and the secondary air may be air, pure oxygen, and/or oxygen-enriched air in various proportions.

**[0018]** The primary air register 44, the gas ring 54, and the secondary air register 64 are disposed in a concentric configuration about the center passageway 34 (FIG. 3). The concentric configuration allows for the centerline tangential injection of the biomass feed from the center passageway 34 into the combustor 14.

**[0019]** The powder cone assembly 30 is provided with a rod 70, a powder cone 72, and a threaded rod 74. The rod 70 having a first end 76 and a second end 78 is substantially disposed in the center passageway 34 of the body 16 of the combustor assembly 10. The

powder cone 72 is disposed on the first end 76 of the rod 70. One end of the threaded rod 74 is connected to the second end 78 of the rod 70 with a pin 80. The threaded rod 74 is connected to an internally threaded flange 82 which is connected to a flange 84 disposed on the first end 18 of the body 16 of the burner assembly 12. The distance between the powder cone 72 and the open second end 20 of the body 16 of the burner assembly 12 may be varied by moving the threaded rod 74 so that the rod 70 moves between a first direction and a second direction. In the first direction, the powder cone 72 moves away from the second end 20 of the body 16 of the burner assembly 12 and in the second direction, the powder cone 72 moves toward the second end 20 of the body 16 of the burner assembly 12. It should be understood that the powder cone 72 may be configured in various ways so long as the powder cone 72 is movable between the first and second directions as described herein.

**[0020]** The body 16 of the burner assembly 12 is also provided with a flame detector 90 for monitoring the formation of a stable combustion region in the burner assembly 12 and a sight glass 92.

**[0021]** Referring now to FIGS. 1 and 4, broadly, the combustor 14 includes a housing 100 and a chamber 102 having a sidewall 104 disposed in the housing 100. The housing 100 has a first end 106 and a second end 108. The first end 106 of the housing 100 is provided with an opening 110 disposed substantially along a centerline of the housing 100 of the combustor 14. The opening 110 substantially tapers outwardly

from the first end 106 of the housing 100 of the combustor 14 toward the chamber 102 of the housing 100.

**[0022]** The second end 20 of the body 16 of the burner assembly 12 and the first end 106 of the housing 100 of the combustor 14 are shaped and configured so that the second end 20 of the body 16 of the burner assembly 12 is disposed in the chamber 102 of the housing 100 of the combustor 14. The second end 20 of the body 16 of the burner assembly 12 is provided with a flange 112 for connecting to an external flange 114 extending a distance from the first end 106 of the housing 100 of the combustor 14 which connects the burner assembly 12 to the combustor 14. It should be understood by one of ordinary skill in the art that the combustor 14 may be any size and shape so long as the combustor 14 functions in accordance with the present disclosure as described herein.

**[0023]** From the above description, it is clear that the present disclosure is well adapted to carry out the objects and to attain the advantages mentioned herein, as well as those inherent in the invention. While present embodiments have been described for purposes of this disclosure, it will be understood that numerous changes may be made which will readily suggest themselves to those skilled in the art and which are accomplished within the spirit of the invention as disclosed and claimed herein.

**What is claimed is:**

1. A burner assembly, comprising:
  - a body having a first end and an open second end and a center passageway extending therebetween;
  - a biomass inlet for receiving biomass such that the biomass inlet is in communication with the center passageway so that biomass is injected from the center passageway by the open second end along a tangential centerline of the body;
  - a primary air inlet for receiving primary air;
  - a gas inlet for receiving a gas; and
  - a secondary air inlet for receiving secondary air.
2. The burner assembly of claim 1 further comprising a biomass intake tube in communication with the center passageway of the body.
3. The burner assembly of claim 1 wherein the primary air inlet is in communication with a primary air register.
4. The burner assembly of claim 1 further comprising a gas ring in communication with the gas inlet.
5. The burner assembly of claim 1 wherein the primary air is air, pure oxygen, or oxygen-enriched air.
6. The burner assembly of claim 1 wherein the secondary air is air, pure oxygen, or oxygen-enriched air.

7. The burner assembly of claim 1 further comprising a powder cone substantially disposed in the center passageway of the body of the burner assembly.

8. The burner assembly of claim 7 wherein the powder cone is movable so that the distance varies between the powder cone and the second end of the body of the burner assembly.

9. A combustor assembly, comprising:

a burner assembly comprising:

a body having a first end and an open second end and a center passageway extending therebetween;

a biomass inlet for receiving biomass such that the biomass inlet is in communication with the center passageway so that biomass is injected from the center passageway by the open second end along a tangential centerline of the body;

a primary air inlet for receiving primary air;

a gas inlet for receiving a gas; and

secondary air inlet for receiving secondary air; and

a combustor connected to the burner assembly.

10 The combustor assembly of claim 9 further comprising a biomass intake tube in communication with the center passageway of the body.

11. The combustor assembly of claim 9 wherein the primary air inlet is in communication with a primary air register.
12. The combustor assembly of claim 9 further comprising a gas ring in communication with the gas inlet.
13. The combustor assembly of claim 9 wherein the primary air is air, pure oxygen, or oxygen-enriched air.
14. The combustor assembly of claim 9 wherein the secondary air is air, pure oxygen, or oxygen-enriched air.
15. The combustor assembly of claim 9 further comprising a powder cone substantially disposed in the center passageway of the body of the burner assembly.
16. The combustor assembly of claim 15 wherein the powder cone is movable so that the distance varies between the powder cone and the second end of the body of the burner assembly.
17. The combustor assembly of claim 9 wherein the second end of the body of the burner assembly and an end of the combustor are shaped and configured so that the second end of the body of the burner assembly is disposed in a portion of the combustor.

18. A method of operating a combustor assembly, comprising the steps of:

injecting a biomass feed material into a center passageway of a body of a burner assembly;

injecting primary air into the body of the burner assembly;

injecting gas into the body of the burner assembly;

injecting secondary air into the body of the burner assembly; and

injecting the biomass feed material along a tangential centerline of the body of the burner assembly into a combustor.

19. The method of claim 18 further comprising drying the biomass feed material to a moisture content of less than about 30%.

20. The method of claim 18 further comprising:

moving a powder cone of the burner assembly a distance between the powder cone and an end of the body of the burner assembly.

1/4

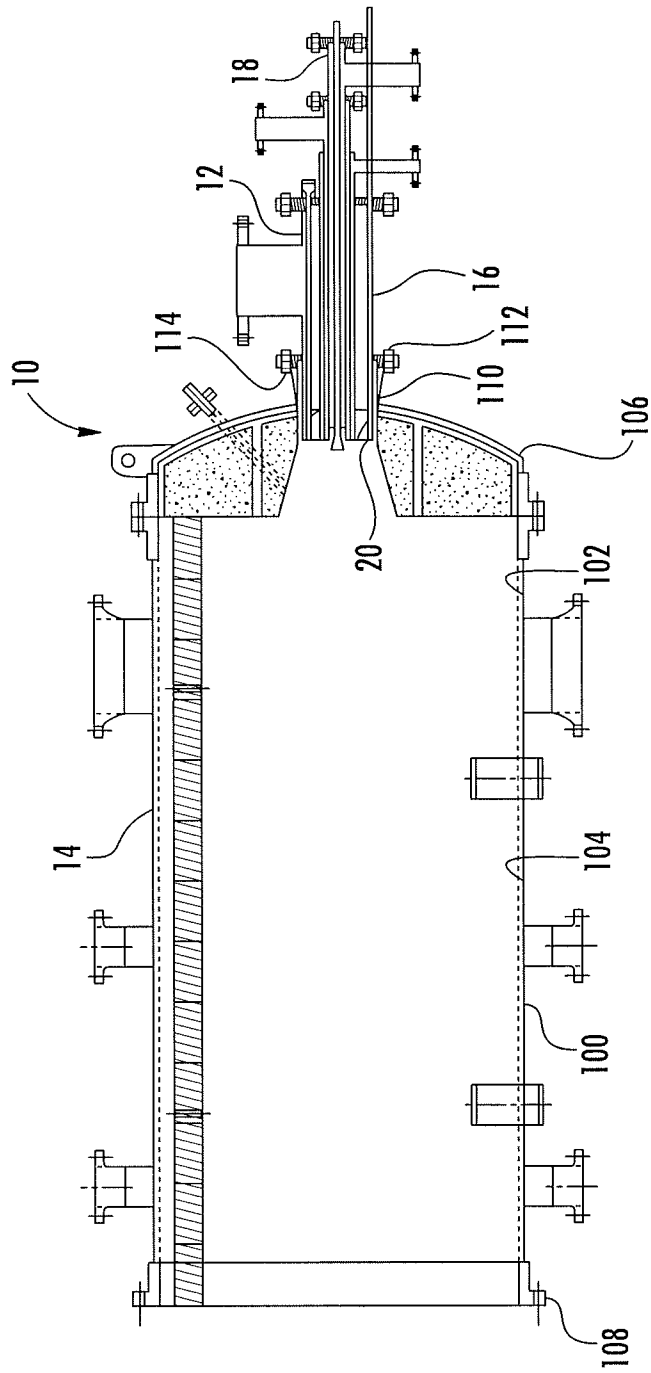

FIG. 7

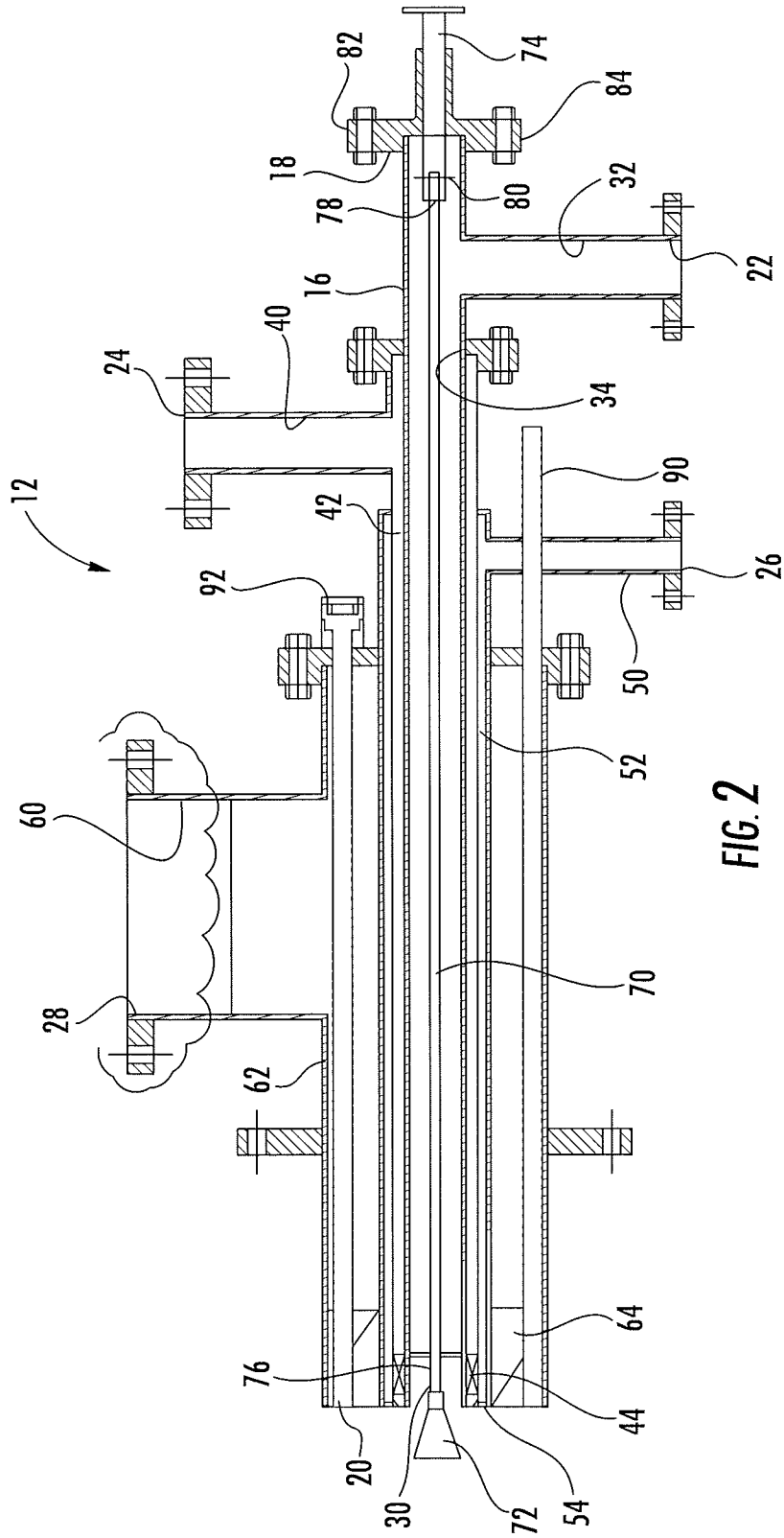

FIG. 2

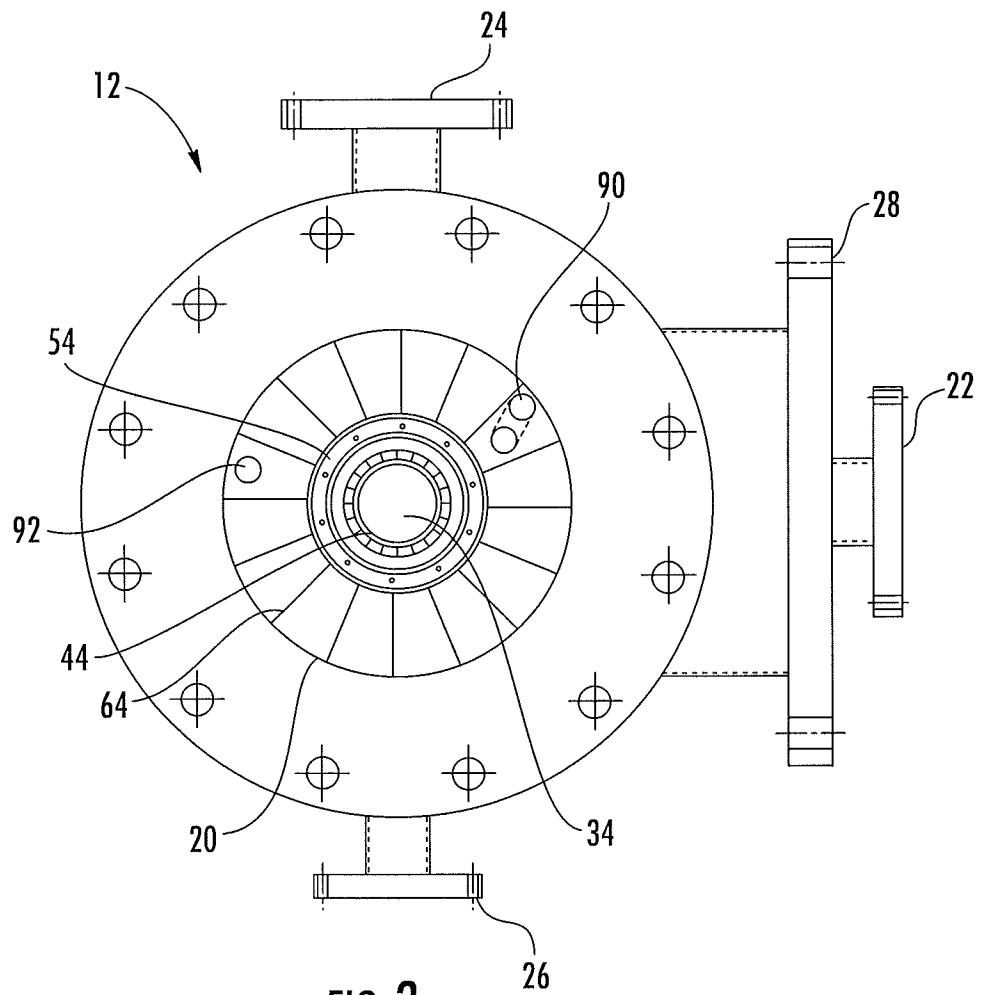
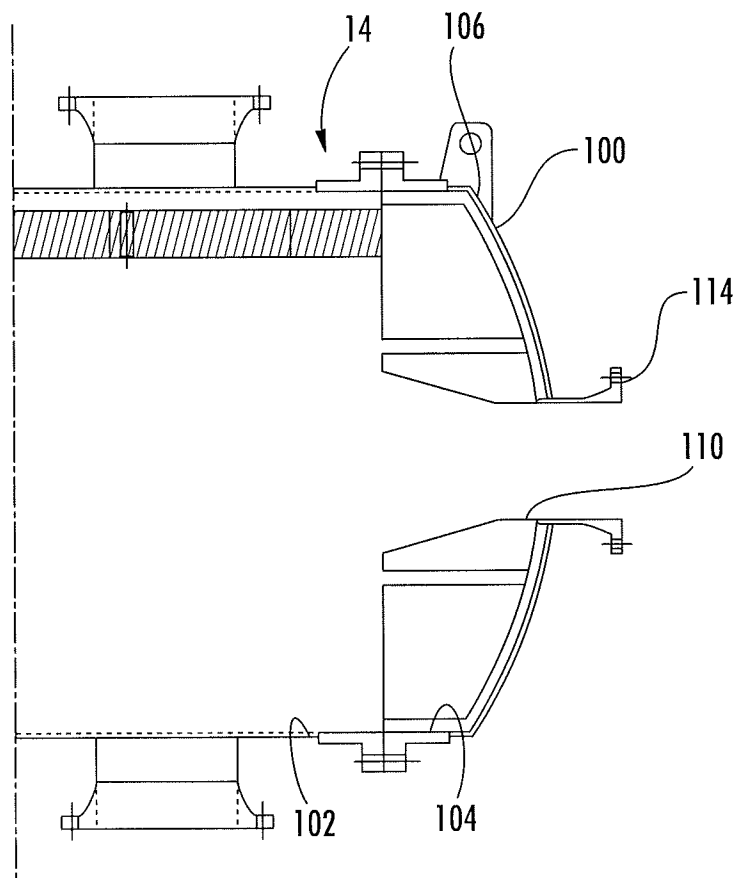

FIG. 3



**FIG. 4**

## INTERNATIONAL SEARCH REPORT

International application No.  
**PCT/US2013/074115****A. CLASSIFICATION OF SUBJECT MATTER****F23D 1/00(2006.01)i, F23D 1/02(2006.01)i, F23D 14/22(2006.01)i, F23D 14/24(2006.01)i**

According to International Patent Classification (IPC) or to both national classification and IPC

**B. FIELDS SEARCHED**Minimum documentation searched (classification system followed by classification symbols)  
F23D 1/00; F23K 5/00; F23D 1/02; F23D 14/22; F23D 14/24Documentation searched other than minimum documentation to the extent that such documents are included in the fields searched  
Korean utility models and applications for utility models  
Japanese utility models and applications for utility modelsElectronic data base consulted during the international search (name of data base and, where practicable, search terms used)  
eKOMPASS(KIPO internal) & Keywords: combustor, burner, biomass, wood, inlet, air, gas, tangential, and slag**C. DOCUMENTS CONSIDERED TO BE RELEVANT**

Category*	Citation of document, with indication, where appropriate, of the relevant passages	Relevant to claim No.
Y	US 4,206,712 A (VATSKY, JOEL) 10 June 1980 See abstract; column 3, lines 25-30,48-59, column 4, lines 4-11,17-23, column 5, lines 27-38, column 6, lines 27-29, column 8, lines 16-19; and figures 1-4.	1-20
Y	US 4,724,780 A (HOFFERT et al.) 16 February 1988 See abstract; column 5, lines 48-61, column 6, lines 6-9,36-47, column 7, lines 35-44; and figures 1-3,6.	1-20
Y	US 4,457,241 A (ITSE et al.) 03 July 1984 See abstract; column 3, lines 60-66, column 4, lines 18-21,33-35, column 5, lines 39-46; and figures 1-3.	7,8,15,16,20
A		1-6,9-14,17-19
A	JP 2008-196741 A (IHI CORP.) 28 August 2008 See abstract; paragraphs [0033]-[0035],[0040],[0042],[0046],[0050]; and figures 1,2.	1-20
A	US 4,879,959 A (KORENBERG, JACOB) 14 November 1989 See abstract; column 6, lines 25-31, column 7, lines 12-17,22-63; and figures 3-5,8,13,14.	1-20

 Further documents are listed in the continuation of Box C. See patent family annex.

\* Special categories of cited documents:

"A" document defining the general state of the art which is not considered to be of particular relevance

"E" earlier application or patent but published on or after the international filing date

"L" document which may throw doubts on priority claim(s) or which is cited to establish the publication date of another citation or other special reason (as specified)

"O" document referring to an oral disclosure, use, exhibition or other means

"P" document published prior to the international filing date but later than the priority date claimed

"T" later document published after the international filing date or priority date and not in conflict with the application but cited to understand the principle or theory underlying the invention

"X" document of particular relevance; the claimed invention cannot be considered novel or cannot be considered to involve an inventive step when the document is taken alone

"Y" document of particular relevance; the claimed invention cannot be considered to involve an inventive step when the document is combined with one or more other such documents, such combination being obvious to a person skilled in the art

"&amp;" document member of the same patent family

Date of the actual completion of the international search

21 March 2014 (21.03.2014)

Date of mailing of the international search report

**21 March 2014 (21.03.2014)**

Name and mailing address of the ISA/KR

International Application Division  
Korean Intellectual Property Office  
189 Cheongsu-ro, Seo-gu, Daejeon Metropolitan City, 302-701,  
Republic of Korea

Facsimile No. +82-42-472-7140

Authorized officer

HAN, Joong Sub

Telephone No. +82-42-481-5606

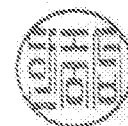

**INTERNATIONAL SEARCH REPORT**

Information on patent family members

International application No.

**PCT/US2013/074115**

Patent document cited in search report	Publication date	Patent family member(s)	Publication date
US 4206712 A	10/06/1980	US 4249470 A US 4253403 A US 4270895 A	10/02/1981 03/03/1981 02/06/1981
US 4724780 A	16/02/1988	BR 8507271 A DE 236334 T1 DE 3584679 D1 EP 0188525 A1 EP 0189459 A1 EP 0236334 A1 EP 0236334 B1 JP 02506708 B2 JP 63-500735 A NO 871827 A NO 871827 D0 US 4671192 A US 4850288 A WO 86-00375 A1 WO 86-00387 A1 WO 87-01432 A1	27/10/1987 14/01/1988 19/12/1991 30/07/1986 06/08/1986 16/09/1987 13/11/1991 12/06/1996 17/03/1988 04/05/1987 04/05/1987 09/06/1987 25/07/1989 16/01/1986 16/01/1986 12/03/1987
US 4457241 A	03/07/1984	JP 58-164910 A JP 62055562 B US 4479442 A	29/09/1983 20/11/1987 30/10/1984
JP 2008-196741 A	28/08/2008	JP 04998001 B2	15/08/2012
US 4879959 A	14/11/1989	AU 1989-03089 A KR 10-1989-0701952 A WO 89-04438 A1	01/06/1989 22/12/1989 18/05/1989