

(No Model.)

2 Sheets—Sheet 1.

A. G. Lyster.
HOPPER AND VALVE FOR HOPPER DREDGERS.

No. 520,210.

Patented May 22, 1894.

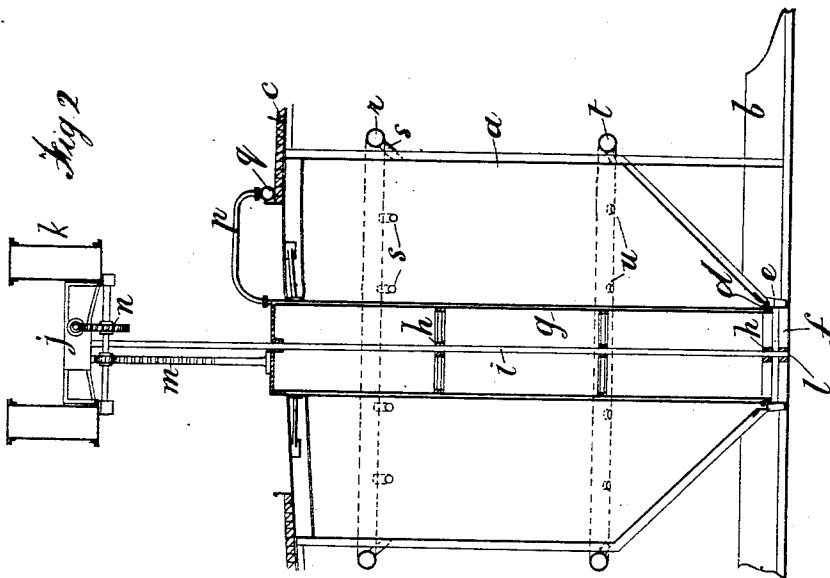
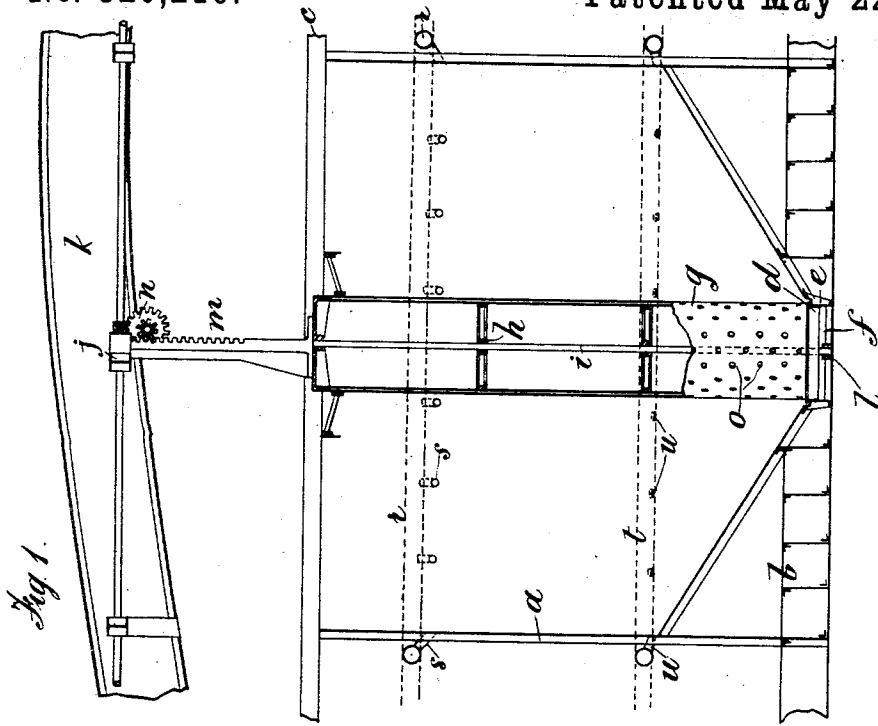

Witnesses
James Johnson
Geo. Procott

Inventor

Arthur G. Lyster

A. G. LYSTER.

HOPPER AND VALVE FOR HOPPER DREDGERS.

No. 520,210.

Patented May 22, 1894.

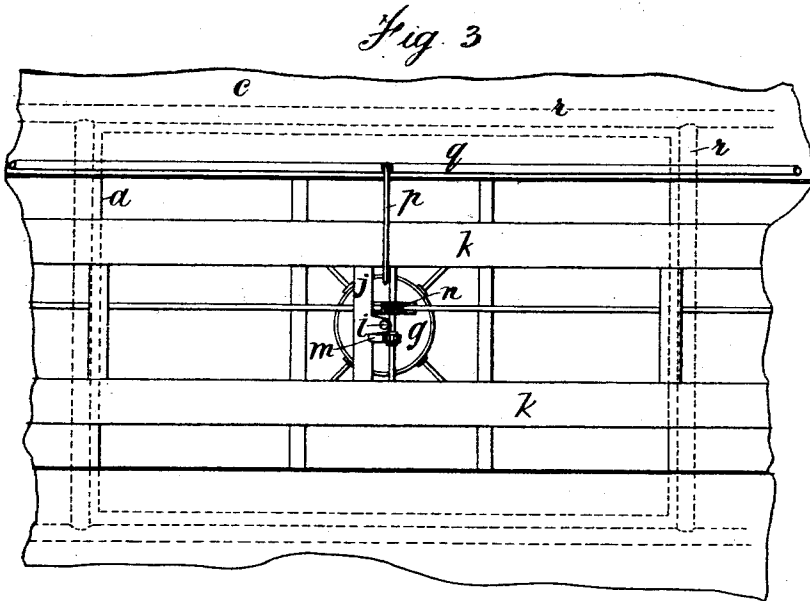
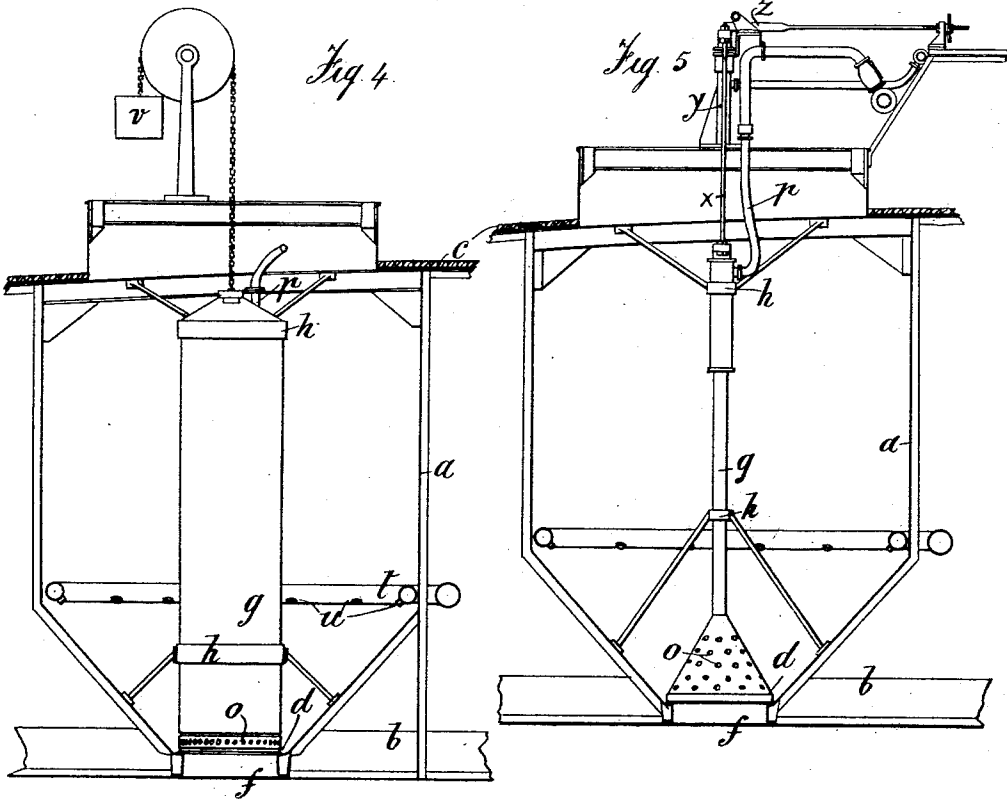

Witnesses

James Johnson
Geo. Brocott

Inventor

Arthur G. Lyster

UNITED STATES PATENT OFFICE.

ANTHONY GEORGE LYSTER, OF LIVERPOOL, ENGLAND.

HOPPER AND VALVE FOR HOPPER-DREDGERS.

SPECIFICATION forming part of Letters Patent No. 520,210, dated May 22, 1894.

Application filed December 30, 1893. Serial No. 495,231. (No model.) Patented in England April 23, 1892, No. 7,676.

To all whom it may concern:

Be it known that I, ANTHONY GEORGE LYSTER, a subject of the Queen of Great Britain, residing at Liverpool, in the county of Lancaster, England, have invented a new and useful Improvement in Hoppers and Valves for Hopper Dredgers or Barges, (for which I have obtained a patent in Great Britain, No. 7,676, bearing date April 23, 1892,) of which the following is a specification.

Figure 1 is a longitudinal vertical section, Fig. 2 is a transverse vertical section, and Fig. 3 a plan of an improved hopper and valve under my invention and Figs. 4 and 5 are vertical sectional views of modified forms.

In the drawings, in which similar letters indicate corresponding parts, *a* are the walls of the hopper or receptacle for containing the dredged matter or spoil.

b is part of the framework of a barge or dredger.

c is the deck of the barge.

d is an annular valve closing against a seat *e* around the discharge opening *f* in the bottom of the barge or dredger. From the said valve a cylindrical jacketed or double walled stem *g* is carried upward above the deck of the barge or dredger through the dredged matter or spoil. The valve *d* is provided with guides *h* which fit freely around a spindle *i* secured at its upper end to a frame *j* carried by crossbeams *k* on the barge and at its lower end to a bearing *l* secured to the sides of the discharge opening *f*.

m is a rack secured to the top of the valve stem *g* and engaging with worm and wheel gearing *n* carried by frame *j* and beams *k*. The jacketed valve stem *g* has the outer wall made with perforations *o* therethrough.

p is a flexible pipe connected to the space between the double walls of the valve stem and to the water supply pipe *q*, so that water may enter the space between the walls of the valve stem and pass out through the perforations so as to lubricate the outer surface of the valve stem and allow of its being easily raised and also to assist in washing down and discharging the dredged matter or spoil when the valve is open.

r is a water supply pipe near the top of the hopper, provided with nozzles *s* which direct water down the inner surface of the hopper

or receptacle and so lubricate it and facilitate the discharge of the dredged matter or spoil. The hopper or receptacle may be made with double walls like the valve stem, the inner one being perforated and the space between being connected to a water supply, but this is more costly without an equivalent increase of efficiency.

t is a water supply pipe near the bottom of the hopper or receptacle provided with nozzles *u* which admit jets of water into the hopper or receptacle so as to propel the dredged matter or spoil toward the opening *f*. The pipes *t* are connected to a main or tank and are provided with taps by which the water is shut off and supplied as required. As many hoppers or receptacles are arranged in the barge or dredger as are found convenient.

When it is desired to discharge a hopper, water is allowed to flow through the perforations *o* over the surface of the valve stem and the valve is then readily raised by actuating the worm gear, after which, water is caused to flow through the nozzles *s* so as to lubricate the surface of the hopper or receptacle and free the dredged matter or spoil therefrom, and through the nozzles *u* to force the dredged matter or spoil out of the opening *f*.

In the modified construction of Fig. 4, the stem *g* of the cylindrical valve *d* is carried by external guides *h*. The said valve stem *g* is in the form of a closed chamber having perforations *o*, and water is caused to flow into the valve stem and out of the perforations through the sliding pipe *p*. The valve is here shown provided with a balance weight *v* so that it may be readily raised and lowered by hand or otherwise. The upper pipe *r* of Figs. 1, 2 and 3 may be dispensed with as shown and the dredged matter or spoil moved by water passing through the lower pipe *t*, only.

Either of the above forms of valve may be constructed in the form of an inverted truncated cone.

Fig. 5 is a vertical section of a modification of apparatus in which a conical perforated valve *d* is used instead of a cylindrical valve. The said valve is provided with a hollow stem *g* which may move freely in guides *h*. The upper end of the said stem is connected to a flexible pipe *p* through which water flows into the valve and out through the perforations *o*.

The said stem g is also connected by rods x to the piston of a hydraulic cylinder y by which the said valve may be raised and lowered. The said cylinder and operating mechanism is of any usual type.

z is a wedge for preventing the valve from rising owing to the pressure of water beneath.

It will be obvious that many modifications may be made without departing from the main features of my invention.

I claim—

1. A hopper or receptacle, having an opening in its bottom, a hollow perforated valve arranged to close said opening, and means for forcing a fluid outwardly through the perforations in order to interpose a fluid film between the valve and the material contained in the hopper; substantially as described.

2. A hopper or receptacle, having a valved bottom outlet, a series of jet openings in the perimeter of the valve thereof, and means for forcing water through said openings in order to interpose a film of water between the hop-

per and the contained material; substantially as described.

3. A hopper or receptacle, having a valved bottom outlet, a series of jet openings in the lower portion of the valve thereof, and means for forcing water through said openings to force out the contained material; substantially as described.

4. A hopper or receptacle, having an opening in its bottom, a hollow perforated valve arranged to close said opening, means for forcing a fluid outwardly through the perforations, a series of jet openings around the perimeter of the hopper, and means for forcing a fluid therethrough; substantially as described.

In testimony whereof I have hereunto set my hand this 15th day of December, A. D. 1893.

ANTHONY GEORGE LYSTER.

Witnesses:

JAMES JOHNSON,
JNO. GROCOTT.