



US008800753B2

(12) **United States Patent**
Kearney et al.

(10) **Patent No.:** **US 8,800,753 B2**
(45) **Date of Patent:** **Aug. 12, 2014**

(54) **SYSTEM FOR CONVEYING AN ARTICLE USING VORTEX SUCTION UNITS**

(75) Inventors: **Peter Xavier Kearney**, Fridingen (DE);
Andreas Wardak, Rottwell (DE)

(73) Assignee: **BDT Media Automation GmbH**,
Rottweil (DE)

(*) Notice: Subject to any disclaimer, the term of this patent is extended or adjusted under 35 U.S.C. 154(b) by 812 days.

(21) Appl. No.: **12/717,505**

(22) Filed: **Mar. 4, 2010**

(65) **Prior Publication Data**

US 2011/0056804 A1 Mar. 10, 2011

Related U.S. Application Data

(63) Continuation of application No. 12/556,734, filed on Sep. 10, 2009, now abandoned.

(51) **Int. Cl.**
B65G 47/00 (2006.01)

(52) **U.S. Cl.**
USPC **198/617**; 198/689.1; 198/811; 271/197

(58) **Field of Classification Search**
USPC 198/689.1, 811, 617; 406/77, 78;
271/3.23, 195, 197
See application file for complete search history.

(56) **References Cited**

U.S. PATENT DOCUMENTS

3,620,526 A * 11/1971 Iles et al. 271/96
3,847,383 A 11/1974 Wojtowicz et al.

3,902,647 A * 9/1975 Neumann et al. 226/97.3
4,148,476 A * 4/1979 Brekell 271/194
4,193,469 A 3/1980 Graf
4,270,879 A * 6/1981 Kacirek 414/788.9
4,368,973 A 1/1983 Silverberg
4,643,413 A 2/1987 Ward et al.
4,822,022 A 4/1989 Attenasio
4,998,715 A * 3/1991 Milan et al. 271/297
5,046,272 A * 9/1991 Vogt et al. 38/143
5,090,676 A 2/1992 Matsuno et al.
5,110,110 A 5/1992 Wirz et al.
5,232,213 A 8/1993 Parsons et al.
5,425,217 A * 6/1995 Lobash et al. 53/435
5,645,274 A 7/1997 Ubayashi et al.
5,671,920 A 9/1997 Acquaviva et al.

(Continued)

FOREIGN PATENT DOCUMENTS

DE 102007022700 A1 11/2008
EP 1975735 A1 10/2008

(Continued)

OTHER PUBLICATIONS

Co-pending U.S. Appl. No. 12/775,522, filed May 7, 2010 entitled "Vortex Suction Separator Device".

(Continued)

Primary Examiner — Joseph Dillon, Jr.

(74) *Attorney, Agent, or Firm* — Leydig, Voit & Mayer, Ltd.

(57) **ABSTRACT**

A system for conveying an article along a transfer path includes at least a first and a second vortex suction unit disposed in sequence in a direction of the transfer path. A conveyor is configured to support the article relative to at least one of the suction units and a main controller is configured to separately control the vortex suction units so as to convey the article along the transfer path using the conveyor.

12 Claims, 12 Drawing Sheets

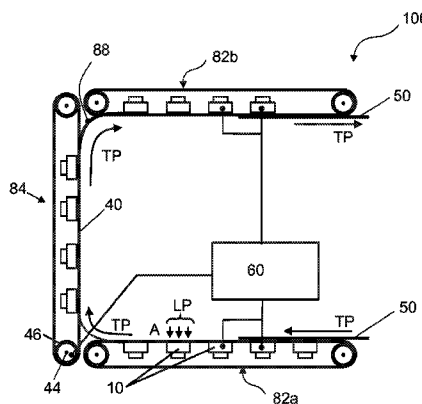
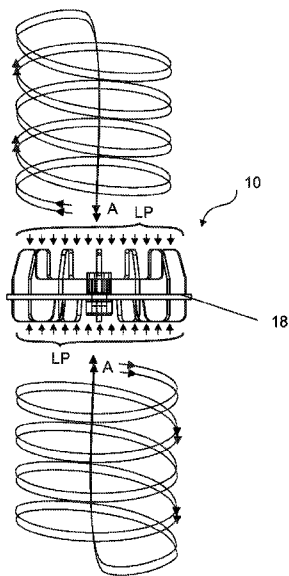

(56)

References Cited

U.S. PATENT DOCUMENTS

5,699,707 A * 12/1997 Campbell, Jr. 83/100
 5,893,554 A 4/1999 Okahashi et al.
 5,971,134 A * 10/1999 Trefz et al. 198/460.1
 6,000,528 A * 12/1999 van Maanen 198/461.1
 6,015,144 A 1/2000 Yoshii et al.
 6,082,728 A 7/2000 Ubayashi
 6,120,016 A 9/2000 Watkiss
 6,216,848 B1 * 4/2001 Zens 198/689.1
 6,402,843 B1 6/2002 Siniaguine et al.
 6,419,217 B1 * 7/2002 Hartmann et al. 270/52.12
 6,497,553 B2 12/2002 Illingworth et al.
 6,565,321 B1 5/2003 Illingworth et al.
 6,595,739 B1 * 7/2003 LaPlace et al. 414/793
 6,595,753 B1 7/2003 Illingworth et al.
 6,729,614 B2 5/2004 Okazaki et al.
 6,729,839 B1 5/2004 Illingworth et al.
 6,802,881 B2 10/2004 Illingworth et al.
 6,811,678 B2 11/2004 Strezov et al.
 6,863,172 B2 * 3/2005 Spatafora et al. 198/370.12
 6,941,973 B2 * 9/2005 Hehmann 138/42
 6,960,063 B2 11/2005 Reinfeld et al.
 7,204,672 B2 4/2007 Sewell
 7,240,465 B2 * 7/2007 Davi' et al. 53/58
 7,284,945 B2 * 10/2007 Ikehata et al. 414/676
 7,293,770 B2 * 11/2007 Edinger 271/276
 7,364,150 B2 4/2008 Nakane
 7,380,781 B2 * 6/2008 Ikeda 271/98
 7,384,035 B2 * 6/2008 Detloff 271/194
 7,568,574 B2 * 8/2009 Nagatomo 198/493
 7,731,186 B2 * 6/2010 Krause et al. 271/193

7,748,697 B2 7/2010 Fujita et al.
 7,841,591 B2 11/2010 Ueda et al.
 7,913,993 B2 3/2011 Kosugi et al.
 7,922,174 B2 * 4/2011 Panides et al. 271/276
 7,958,988 B2 * 6/2011 Miyamoto 198/689.1
 7,987,964 B2 * 8/2011 McCabe 198/471.1
 8,016,115 B2 * 9/2011 Fryars 209/138
 8,083,462 B2 * 12/2011 Barge 414/797.2
 2001/0040062 A1 11/2001 Illingworth
 2002/0155001 A1 * 10/2002 Reinfeld et al. 416/185
 2004/0018089 A1 * 1/2004 Illingworth et al. 416/185
 2004/0089994 A1 5/2004 Koga et al.
 2004/0099504 A1 * 5/2004 Spatafora et al. 198/438
 2005/0133980 A1 6/2005 Koga
 2007/0267274 A1 * 11/2007 Steffen et al. 198/689.1
 2008/0006565 A1 * 1/2008 Fryars 209/718
 2008/0237968 A1 10/2008 Suzuki
 2009/0127768 A1 5/2009 Shima et al.
 2010/0007082 A1 1/2010 Mueller et al.
 2010/0148419 A1 6/2010 Suzuki
 2011/0293346 A1 * 12/2011 Sato 400/578

FOREIGN PATENT DOCUMENTS

GB 2295799 A 7/1996
 GB 2343879 A1 5/2000
 JP 62016947 A 1/1987

OTHER PUBLICATIONS

Co-pending U.S. Appl. No. 12/900,029, filed Oct. 7, 2010, entitled "Stack Feeding Aeration Device and Method".

* cited by examiner

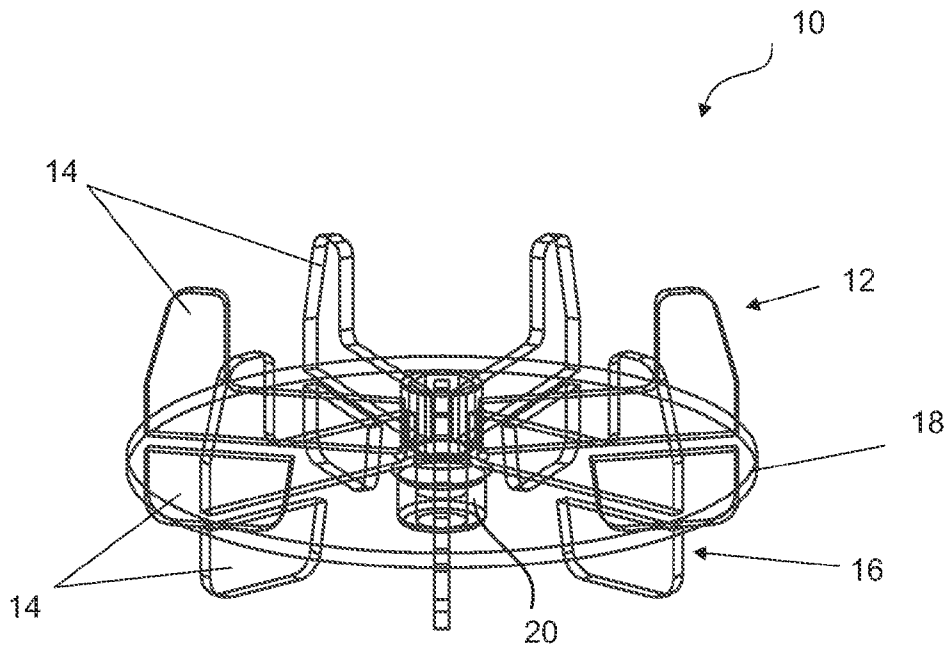

Fig. 1

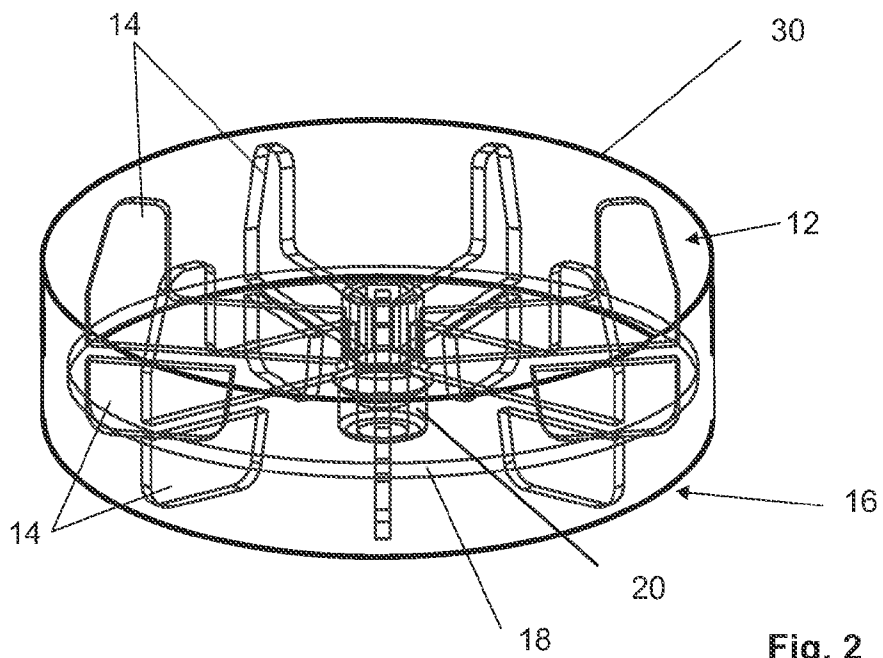
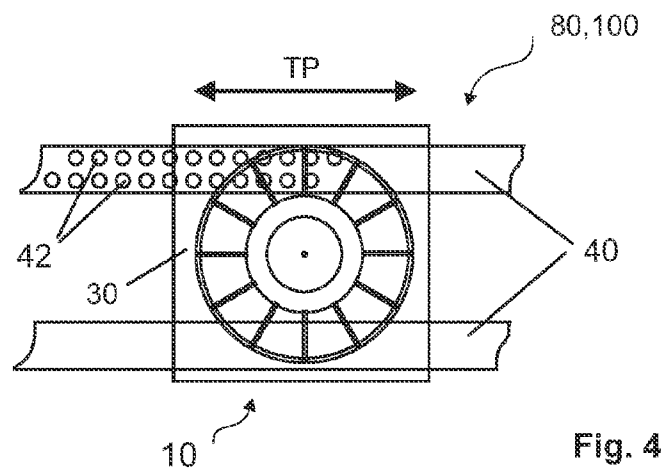
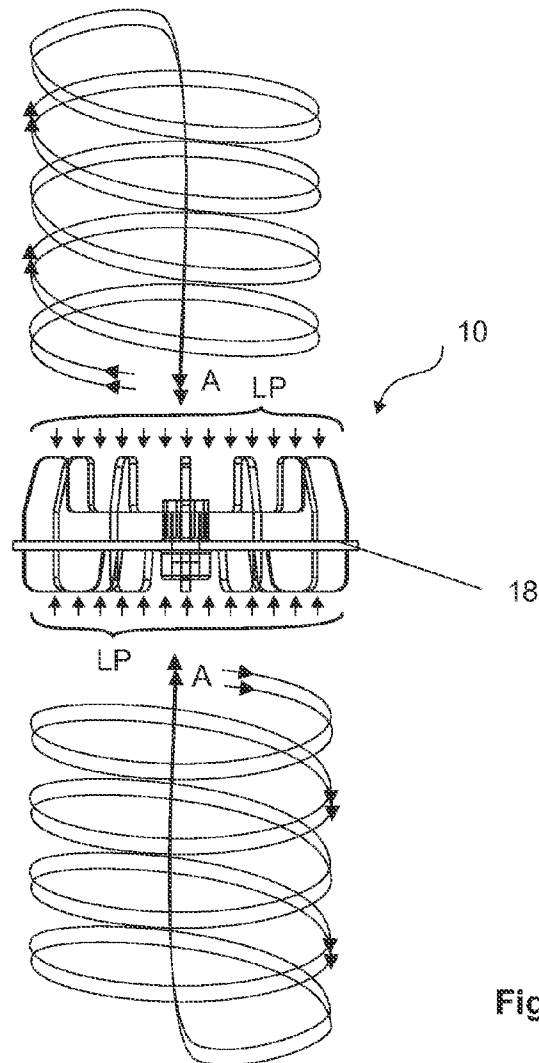

Fig. 2



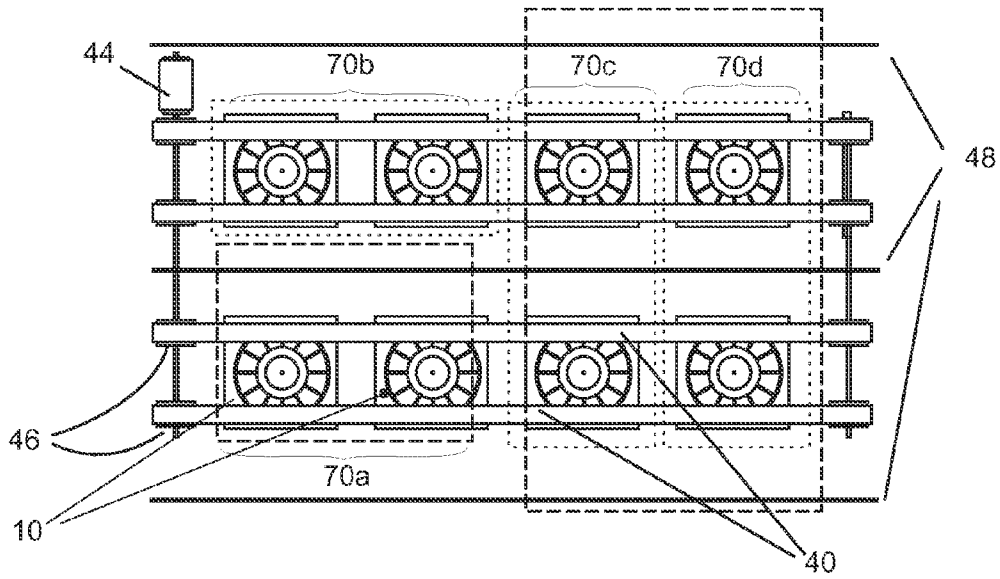

Fig. 5

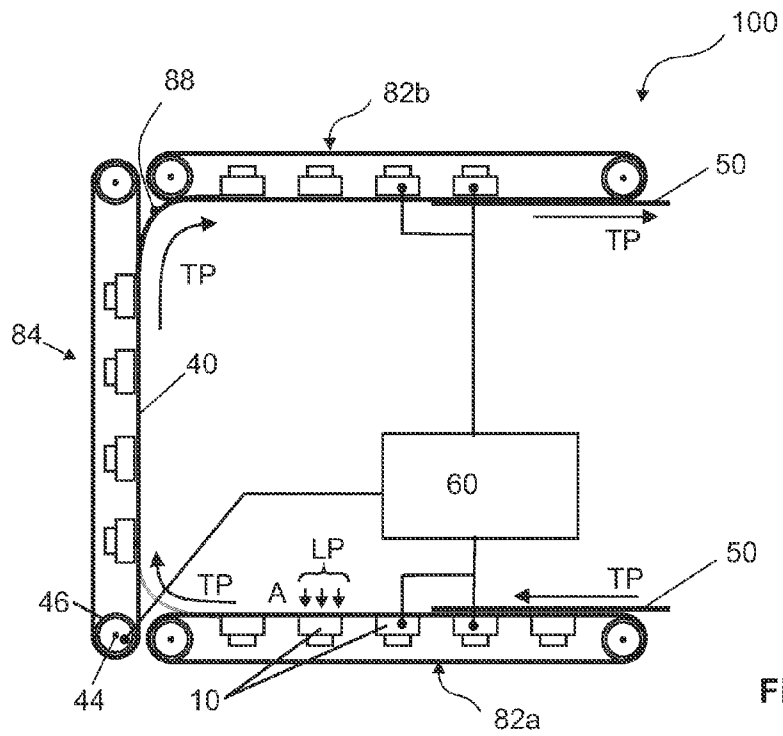

Fig. 6

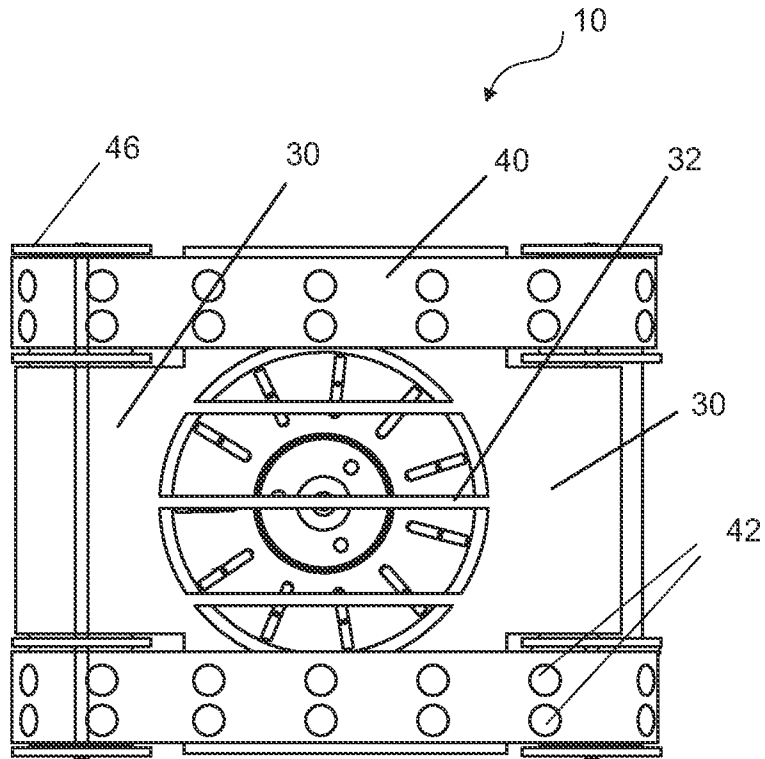

Fig. 7

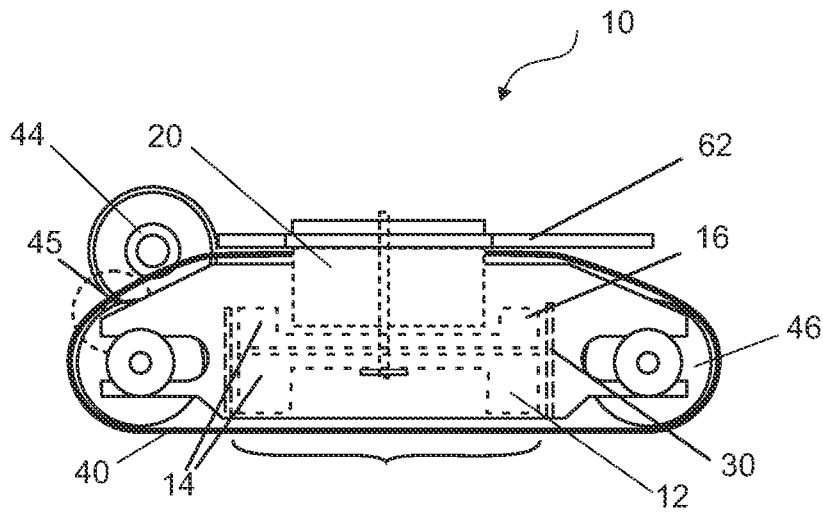

Fig. 8

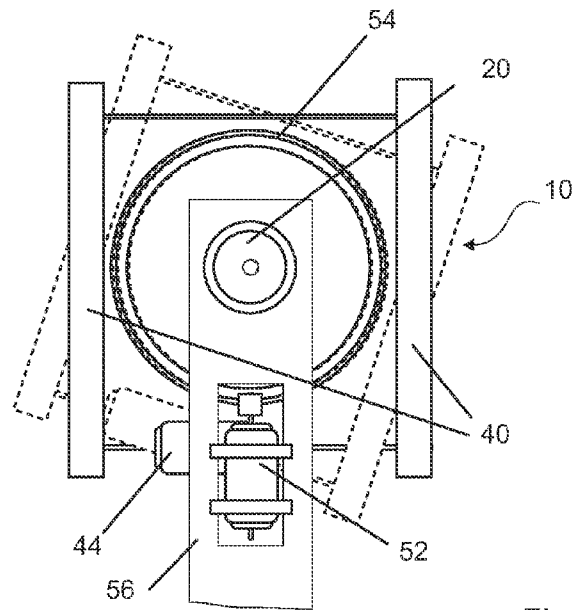

Fig. 9

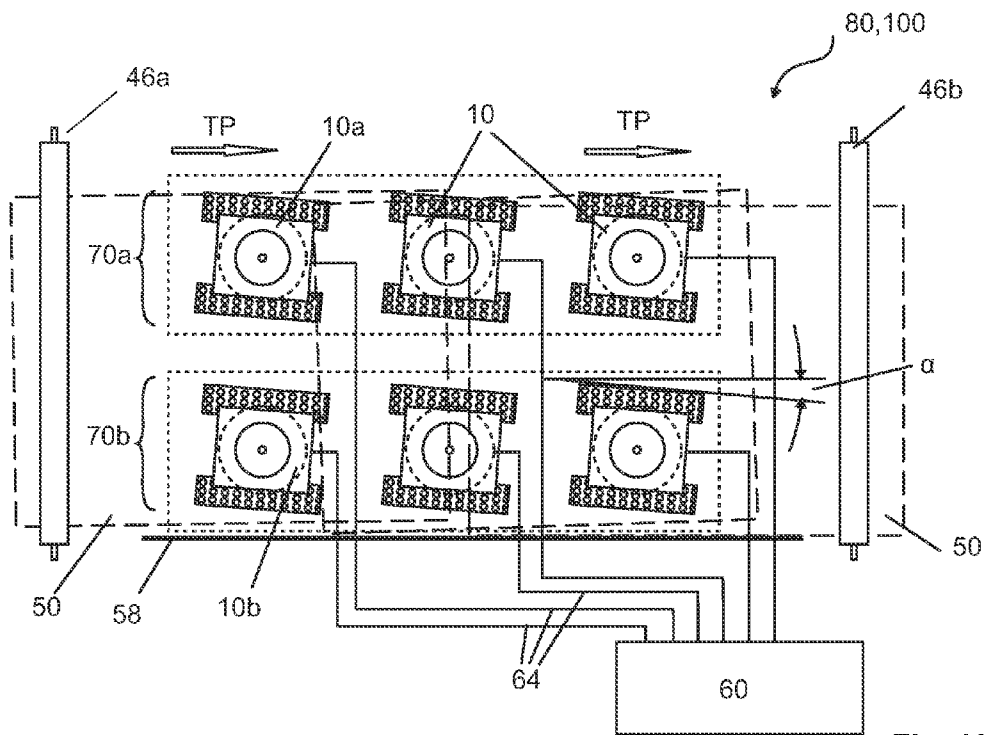

Fig. 10

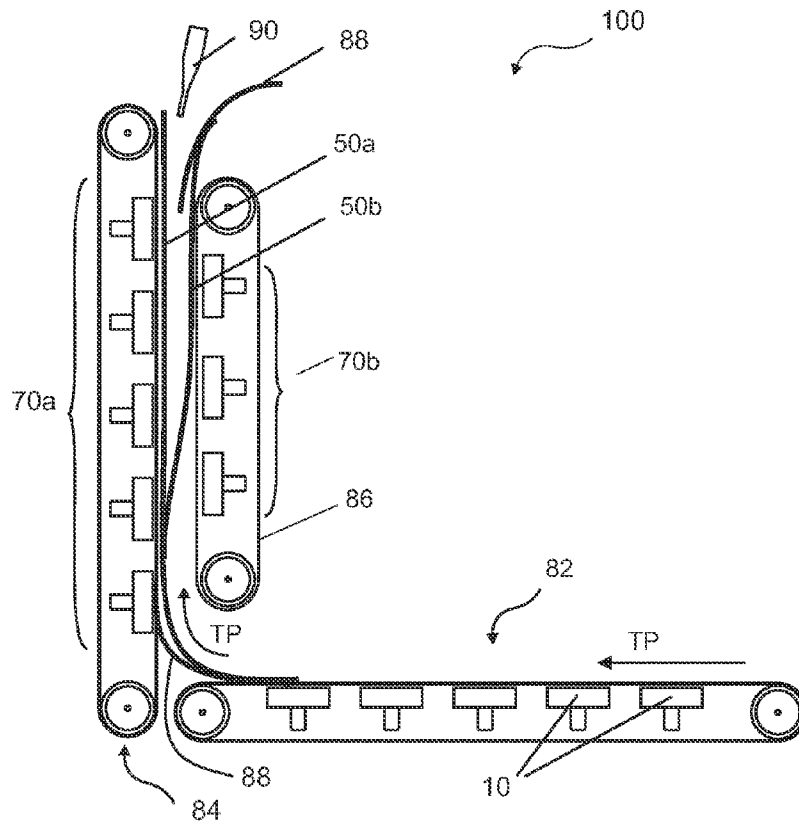

Fig. 11

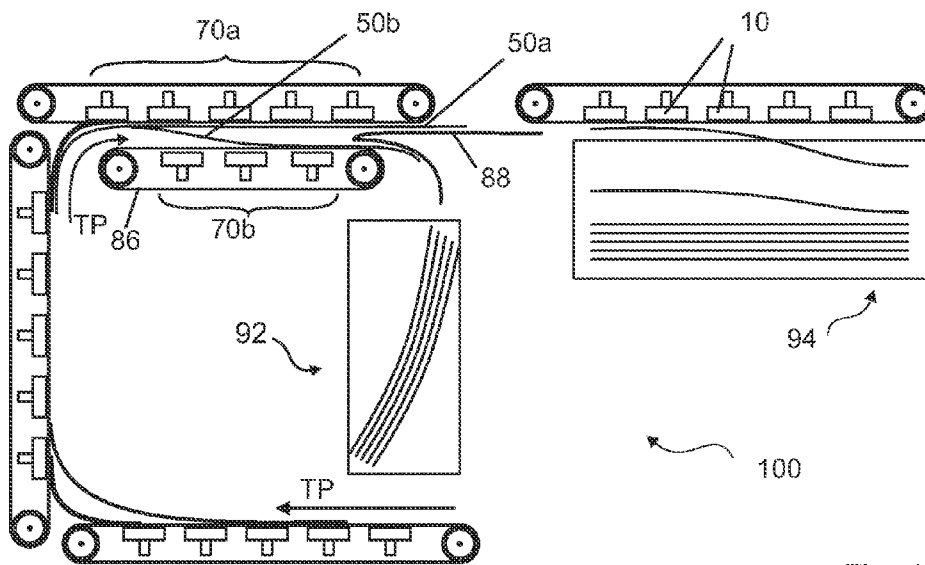

Fig. 12

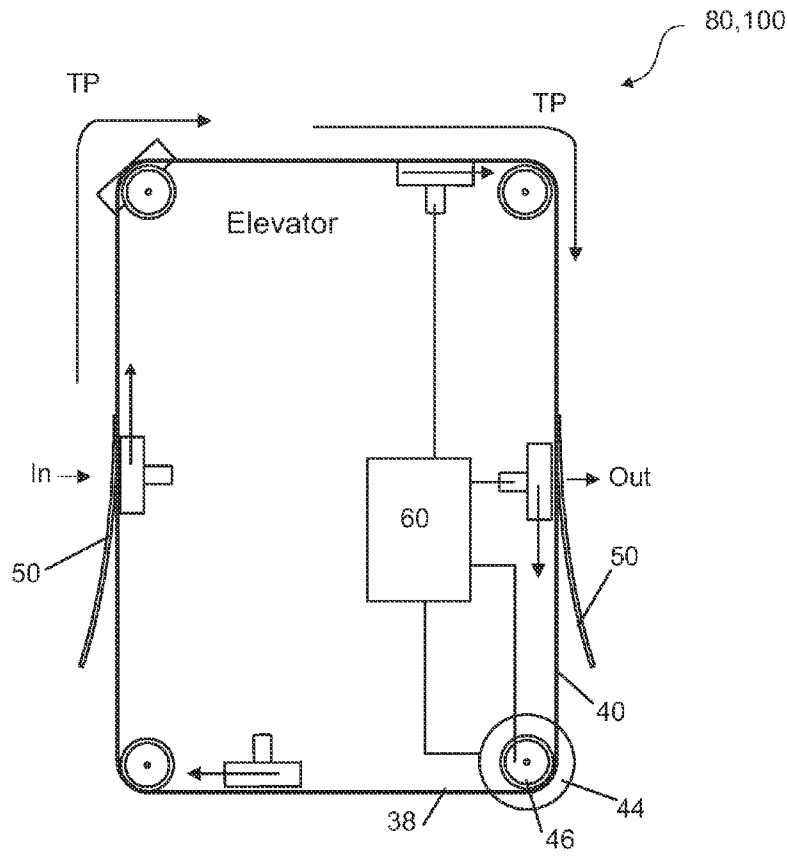

Fig. 13

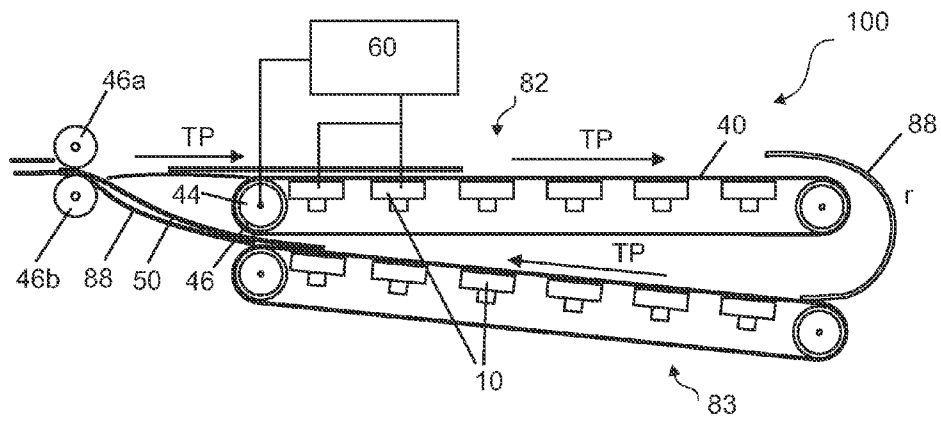

Fig. 14

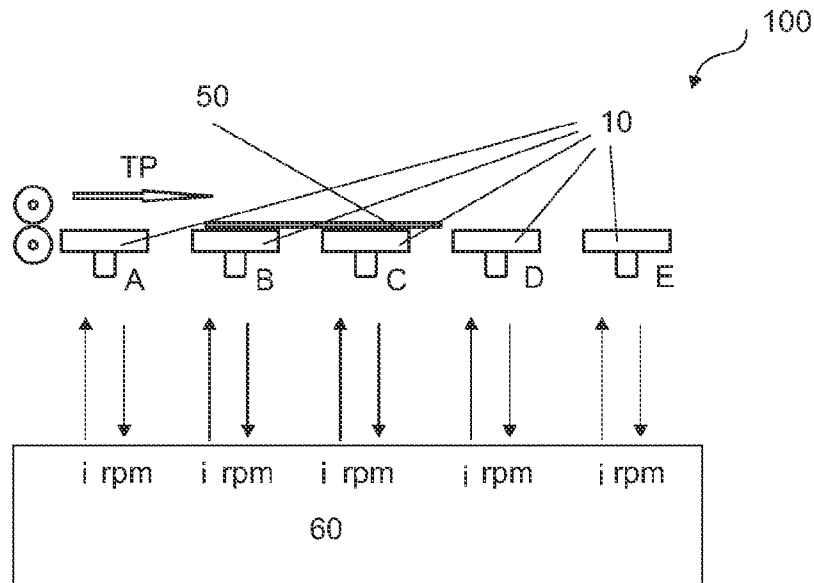

Fig. 15

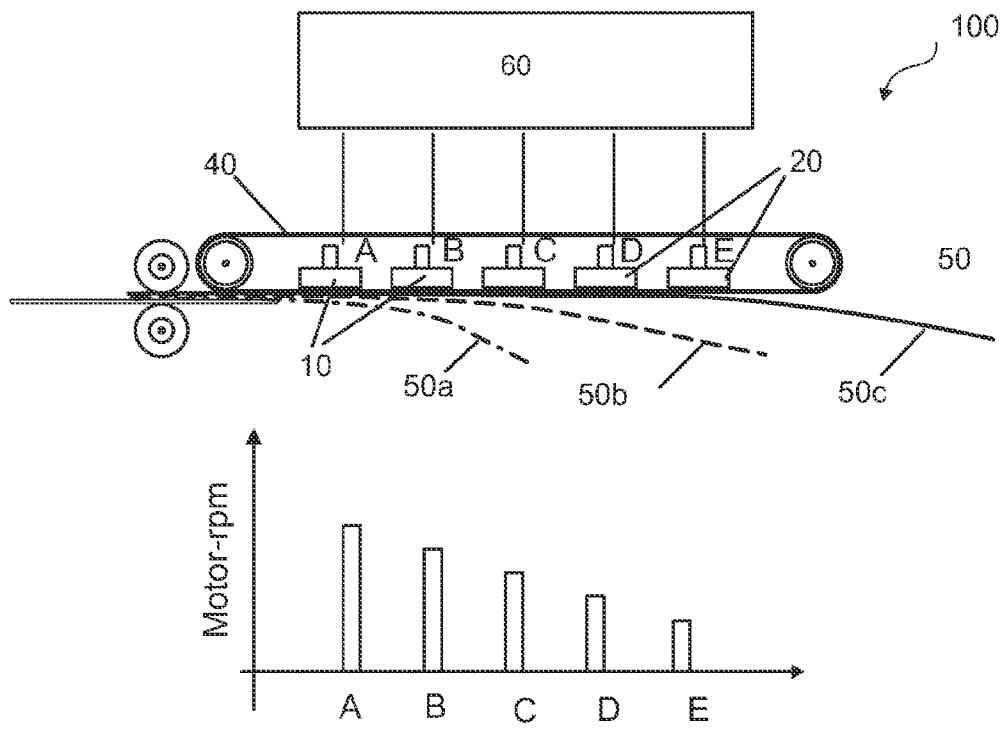

Fig. 16

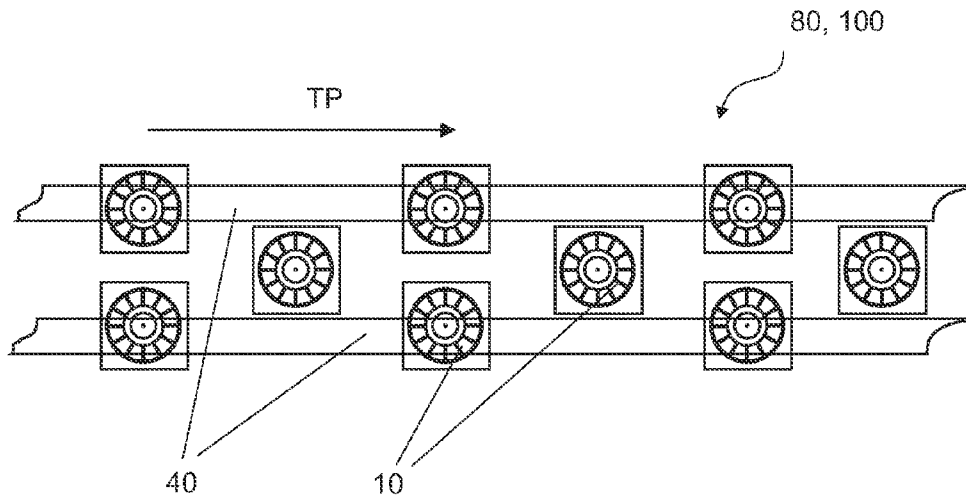

Fig. 17

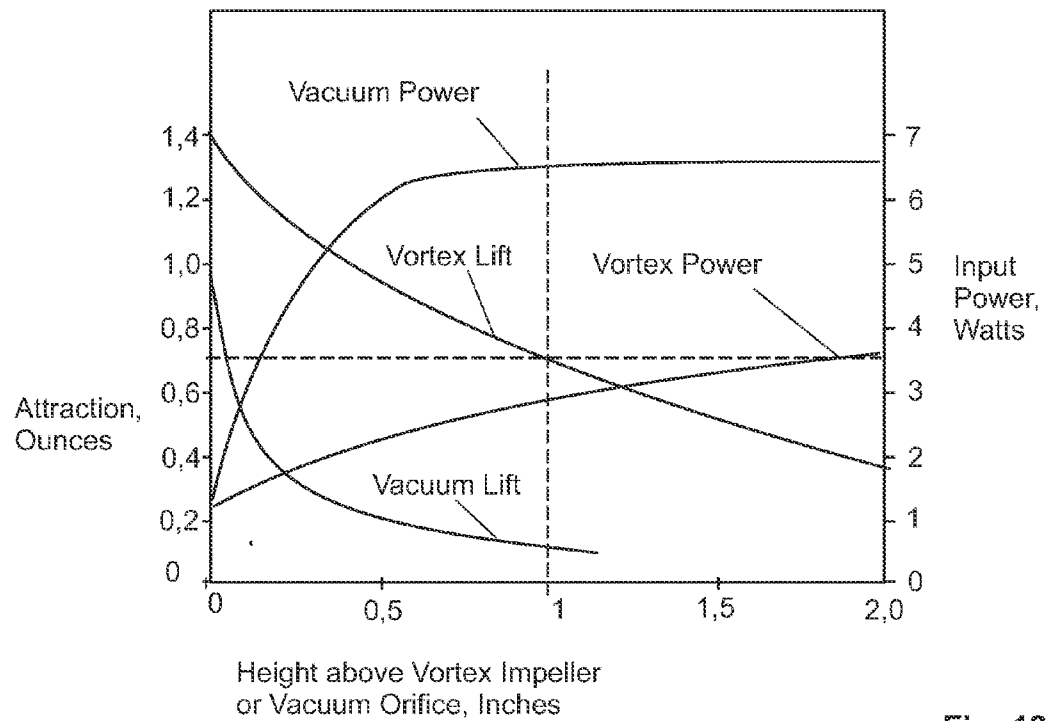

Fig. 18

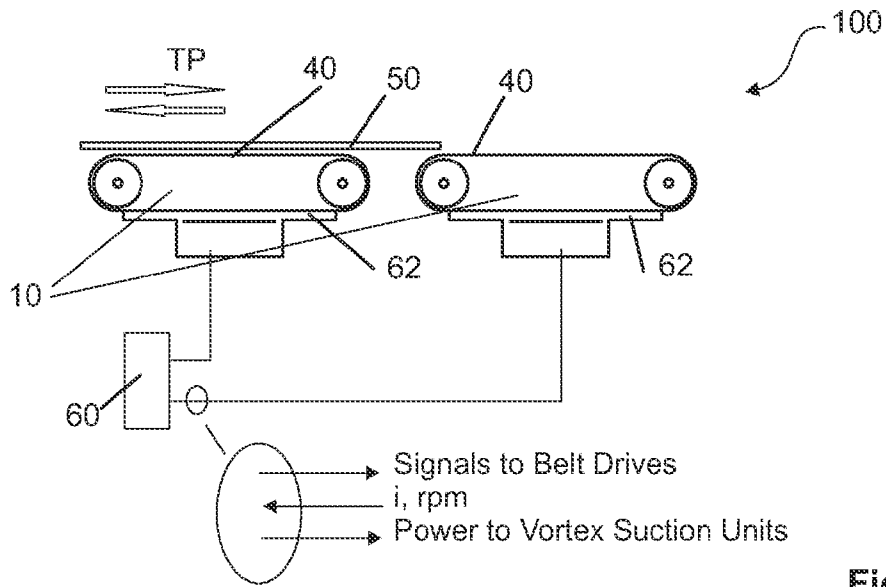

Fig. 19

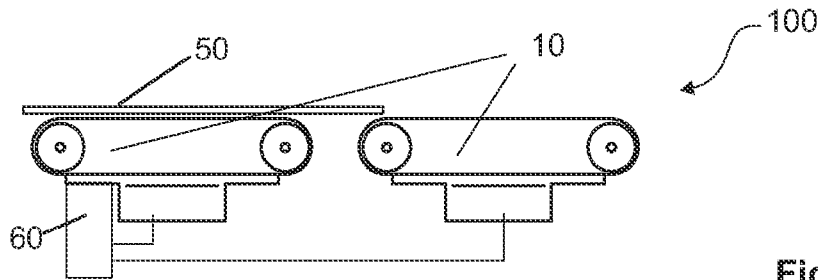

Fig. 20

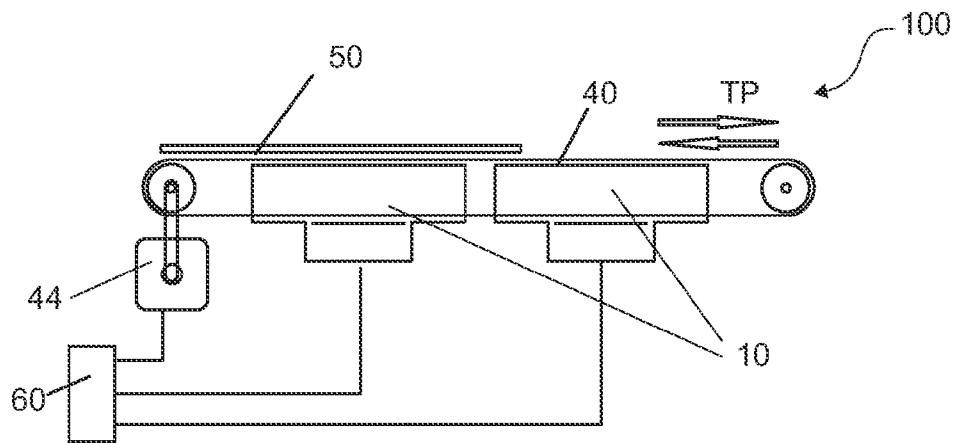

Fig. 21

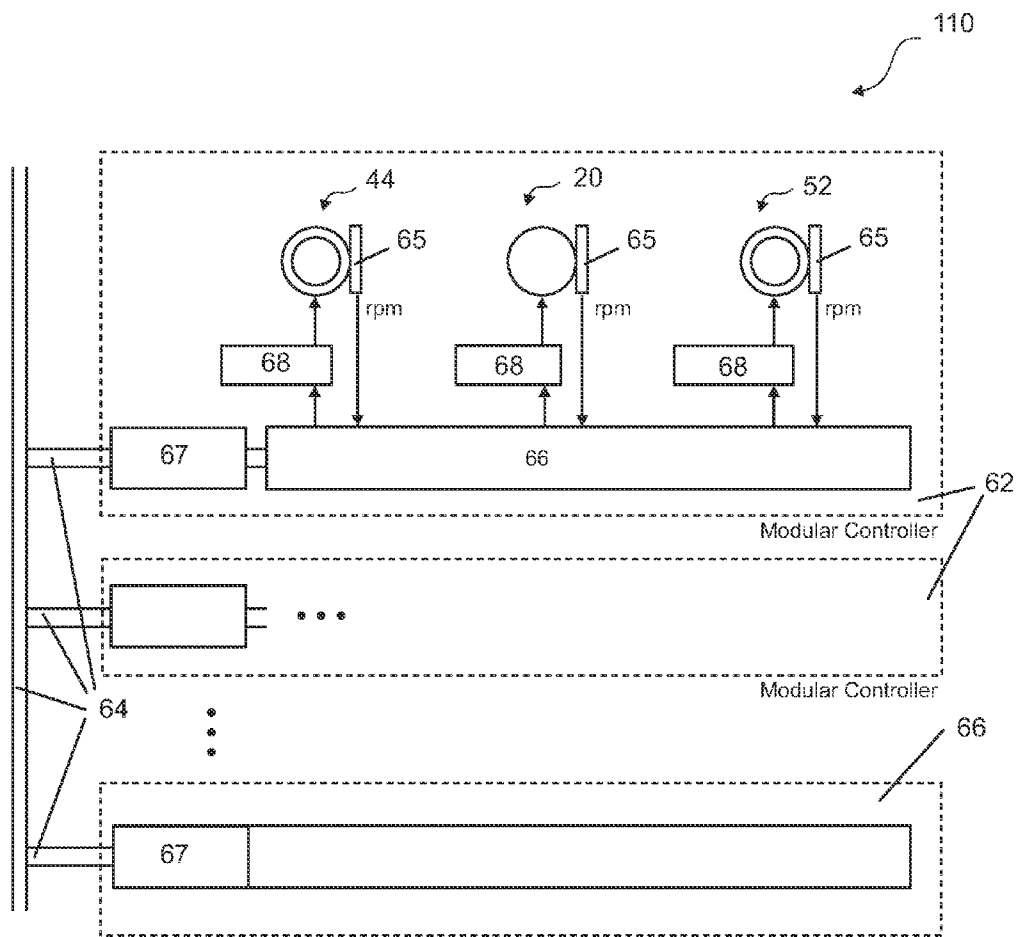

Fig. 22

SYSTEM FOR CONVEYING AN ARTICLE USING VORTEX SUCTION UNITS

CROSS REFERENCE TO PRIOR APPLICATION

This application is a continuation of U.S. patent application Ser. No. 12/556,734, filed on Sep. 10, 2009, and which is hereby incorporated by reference herein.

FIELD

The present invention relates generally to conveyance systems, and more specifically to a system for conveying an article using vortex suction units.

BACKGROUND

Conveyance systems ordinarily rely on friction drives (i.e., belts or rollers) using gravity as a friction force to maintain an article being conveyed along a transfer path. However, when the article being transported is relatively flat and/or lightweight, ambient air streams can cause the article to get blown off from the conveyor. Additionally, when the conveyor is vertical or inclined, the article is likewise susceptible to sliding, rolling or flying away from the transfer path.

U.S. Pat. No. 5,671,920 describes use of an external low pressure generator for providing an additional force to maintain an article on a conveyor.

U.S. Patent Application Publication No. 2005/0133980 describes use of an axial fan on the opposite side of a belt from paper being conveyed thereon.

U.S. Pat. No. 6,565,321 describes a vortex attractor. An impeller including a plurality of radial blades extending in a direction of the rotation axis are provided to generate a vortex flow. The vortex flow provides a central negative low pressure region which can be used to attract an object or maintain the vortex attractor against or at a distance from a surface.

SUMMARY

In an embodiment, the present invention provides a system for conveying an article along a transfer path including at least a first and a second vortex suction unit disposed in sequence in a direction of the transfer path. A conveyor is configured to support the article relative to at least one of the suction units and a main controller is configured to separately control the vortex suction units so as to convey the article along the transfer path using the conveyor.

BRIEF DESCRIPTION OF THE DRAWINGS

The foregoing and other features of the present invention will be more readily apparent from the following detailed description and drawings of illustrative embodiments of the invention in which:

FIG. 1 is a front view of a vortex suction unit in accordance with an embodiment of the present invention;

FIG. 2 is a perspective view of the vortex suction unit of FIG. 1;

FIG. 3 is a schematic view of the fluid flow generated by the vortex suction unit;

FIG. 4 is a sectional view of the vortex suction unit in a conveyance system;

FIG. 5 is a top view of a conveyor using vortex suction units in accordance with an embodiment of the present invention;

FIG. 6 is a schematic view of a system of conveying an article in accordance with an embodiment of the present invention;

FIG. 7 is a top view of a vortex suction unit having its own means of conveyance;

FIG. 8 is a sectional side view of the vortex suction unit of FIG. 7;

FIG. 9 is a top view of the vortex suction unit of FIG. 7 provided with means for rotating the unit;

FIG. 10 is a top view of a conveyance system including a plurality of vortex suction units of FIG. 9 and a controller connected thereto;

FIG. 11 is a schematic view of a conveyance system illustrative of use of the vortex suction units for double-pick handling;

FIG. 12 is a schematic view of a conveyance system having sorting containers for the handling of a double-pick;

FIG. 13 is a schematic view of a conveyance system having guides for moving the vortex suction units along the transfer path;

FIG. 14 is a schematic view of a flipping portion of a conveyance system;

FIG. 15 is a schematic view illustrating the individual control of vortex suction units as an article is conveyed along the transfer path;

FIG. 16 is a schematic view illustrating the individual control of vortex suction units for conveying and sorting the article;

FIG. 17 is a sectional view of a staggered arrangement of vortex suction units in a conveyance system;

FIG. 18 is a graph comparing attraction force and power consumption of vortex suction units and standard axial fans;

FIG. 19 is a schematic view of a controller for first and second vortex suction units;

FIG. 20 is a schematic view of the controller of FIG. 19 integrated onto the first vortex suction unit;

FIG. 21 is a schematic view of a controller for first and second vortex suction units having a shared belt and belt drive;

FIG. 22 is a schematic view of a main controller and modular controllers in accordance with an embodiment of the present invention; and

FIG. 23 is a schematic view of a conveyance system having two mechanical-guide conveyors and vortex suction units in accordance with the present invention.

Like reference numerals are used in the drawing figures to connote like components of the system.

DETAILED DESCRIPTION

Referring to FIGS. 1-3, a vortex suction unit 10 includes an upper vortex generator 12 driven by a motor 20. The upper vortex generator 12 includes a base 18 concentrically driven by the motor 20 and a plurality of blades 14 radially disposed on the base 18 and extending perpendicularly upwards therefrom. In an embodiment, a similar lower vortex generator 16 including blades 14 is provided on the opposite side of the base 18 in order to provide a cooling flow of air to the body of the motor 20. However, in one embodiment, only the upper vortex generator 12 is provided to generate the attraction force A based upon the principles of a tornado. The motor 20 may be an AC or DC motor. For example, the motor 20 is a brushless DC motor or a stepper motor. The blades 14 may be a number of different shapes, such as curved. In an embodiment, the blades 14 are substantially straight and flat. For example, the blades 14 of the upper vortex generator 12 may include a recessed at an upper, inward and radially-extending

portion thereof. A housing **30** may be provided on the vortex suction unit **10** surrounding the peripheral edge of the base **18** and blades **14**. The housing **30** may be, for example, a shell or a ring. Alternatively, the upper vortex generator **12** and/or the lower vortex generator **16** may be manufactured, for example, by molding, to form a ring surrounding the blades **14**.

A vortex suction unit **10** is any device capable of generating a vortical fluid flow FF. By way of example, a vortex attractor as described in U.S. Pat. No. 6,565,321 or in U.S. Pat. No. 7,204,672, which are hereby incorporated by reference herein, may be used. The radially extending blades **14** generate the fluid flow FF helically containing a low pressure region LP within the vortex generator **12** inside the peripheral edges of the blades **14**. An attraction force A is generated in the low pressure region LP which allows the vortex suction unit **10** to both attract and move toward (when the vortex suction unit **10** is not fixed) the surface of an object. Vortex suction units **10** are effective to removably adhere to planar and non-planar surfaces or to maintain the same at a predetermined distance. It is also noted that the vortex suction units **10** may be modified to apply a negative attraction force A, or a repulsion force, to push an article **50** away.

In one embodiment, the upper and lower vortex generators **12**, **16** are formed from a lightweight material, such as plastic, and have a diameter of approximately 50 mm. In this manner, the rotational inertia is kept low such that the vortex suction module can be started and stopped quickly. Likewise, the speed may be adjusted quickly and easily. The motor **20** is a brushless DC motor which responds quickly to changes in power level to adjust its rotations per minute (rpm). At about 22,000 rpm, the vortex suction unit **10** generates an attraction force A of about 1.3 N throughout the low pressure region LP. Referring to FIG. **18**, a comparison is made for illustrative purposes between a vortex impeller and a vacuum suction chamber having a fan configured for low pressure generation (vacuum power). In addition to being responsive to power changes to quickly change speed and thereby increase or decrease its attraction force, the vortex impeller is also far more efficient and effective than the vacuum system when at a distance from an object to be adhered; this is a desirable positioning for proper conveyance to allow room for belts and/or prevent sticking. For example, where the article **50** is disposed at a distance of 1.0 mm from the upper vortex generator **12**, an attraction of approximately 0.7 ounces is achieved while consuming only about 3.5 Watts of power. In contrast, at the same distance of 1.0 mm, the fan of the vacuum generator consumes approximately 6.5 Watts of power while providing attraction for only about 0.1 ounces.

Referring to FIGS. **4-6** and **17**, vortex suction units **10** are disposed adjacent a transfer path TP, the direction of which is indicated by arrows. An article **50** is moved by a conveyor **80** along the transfer path TP by belts **40** and/or friction rollers **46**. The transfer path TP corresponds to the predetermined conveyance positions of the article **50** as it moves along the conveyor **80**. The vortex suction units **10** are arranged in sequence along the transfer path TP and may also be disposed into arrays **70** which may be, for example, vertical arrays **70a**, **70b** arranged side by side or sequentially arranged horizontal arrays **70c**, **70d**. It is also possible to provide the vortex suction units **10** in an offset arrangement (see FIG. **17**) in order to reduce the total number of vortex suction units **10** necessary for a particular conveyor **80**. The vortex suction units **10** may be arranged side by side, and may be arranged with a predetermined spacing which is less than the length of a respective edge of the article **50** such that it is adhered to the belts **40** at all points during conveyance.

The housings **30** of the vortex suction units **10** may be square or other shapes and surround the outside edges of the blades **14**. A cover **32**, which may be a screen, a grid, concentric circles, an air permeable material, a plate with openings or ribs, may be provided on the vortex suction units **10**. In an embodiment shown in FIG. **7**, the cover **32** includes ribs extending in the direction of the transfer path TP such that an article **50** which is flexible, such as paper, is provided a slight corrugation in the direction of the transfer path TP. The housing **30** may also include idler balls or rollers which contact the article **50** during conveyance to decrease friction.

The cover **32** may be provided to minimize risk of injury, keep objects from interfering with the blades, to maintain a spacing to the article **50** and/or to aid in guiding and supporting the article **50** as it moves along the transfer path TP. In an embodiment, the cover **32** is disposed at a distance from the article **50** such that a flexible article **50** being carried by belts **40** is given a concave or corrugation shape by vortex suction units **10** positioned between pairs of belts **40**, thereby imparting a degree of rigidity. Further, covers **32** may extend between vortex suction units **10** so as to provide a smooth, supported transition as the article moves from one vortex suction unit **10** to the next.

The belts **40** may be formed from a material having a significant coefficient of friction and may be toothed, such as in a synchronous type conveyor, textured or profiled. For example, spikes, grooves or ribs may be provided on the surface of the belts **40**. Typical elastic or elastomeric belts **40** are sufficient to convert the normal force into a transport force. The surface of belts **40** may be roughened to increase friction in their entirety or only at certain areas to create a surface having regions with different coefficients of friction. Further, the belts **40** may be at least partially air permeable. For example, the belts **40** may be perforated or formed from a nano-material. The belts **40** may be driven by a belt drive **44**, which may be adjustable to control the conveyance speed.

The conveyor **80** may include support rails **48** which support and assist in maintaining the position of the article **50** in the transfer path TP. In an embodiment, the vortex suction units **10** are arranged on the opposite side of the belts **40** from the article **50** and are positioned between adjacent pairs of belts **40**. However, one air permeable belt **40** may be provided over in lieu of the covers **32**. The belts **40** may also contain a plurality of perforations **42** through which the attraction force A adheres the articles **50** to the belts **40**, in which case the conveyor **80** includes just one belt **40** or multiple parallel belts **40**.

Other types of conveyors **80** are also possible, such as ones using sequentially arranged driven rollers with a spacing therebetween, in which case the vortex suction units **10** are arranged below the spacings and provide the attraction force A to the article **50** therethrough. Likewise, conveyors **80** include other systems of conveyance, such as supports, for example, support rods or rollers, arranged such that the article is conveyed by gravity or an applied force.

The conveyors **80**, may be horizontal conveyors **82**, vertical conveyors **84**, and may also be inclined, curved, rectangular, circular, or the like. For example, as shown in FIG. **6**, an article **50** enters the transfer path TP on top of a first horizontal conveyor **82a**, traveling to a vertical conveyor **84** and up to the bottom of a second horizontal conveyor **82b**, wherein the attraction force A of the vortex suction units **10** is sufficient to hold the article **50** against the belts **40** even in the presence of a gravitational force downward. In this conveyance system **100**, the article **50** is both flipped and translated upwards by the design of the transfer path TP. Especially when the article **50** is relatively flat and flexible, such as paper, deflectors **88**

may be provided between conveyors **80** that are separated and/or at angles relative to one another, such as horizontal and vertical conveyor **82**, **84**, to direct the article **50** onto the respective belts **40** or other conveyance surface. Further, a main controller **60** may be provided to control belt drives **44** and vary the conveyance speed of the conveyors **82a**, **82b**, **84** and/or to control the attraction force provided by the vortex suction units **10** either individually (separately) or in groups. For example, since the second horizontal conveyor **82b** must adhere the article **50** against gravity, the vortex suction units **10** therein can be driven at a higher speed than those of the first horizontal conveyor **82a**. Similarly, the attraction force **A** may be increased when a heavier article **50** enters the transfer path.

Referring to FIGS. 7-10, each vortex suction unit **10** may be provided with its own means of conveyance, such as, for example, its own pair of belts **40** having perforations **42** that are driven by traction rollers **46** connected to a belt drive **44**. A cover **32** having ribs is provided on the housing **30** over the upper vortex generator **12** parallel to the belts **40** to provide a slight corrugation to flexible articles **50** in conveyance direction and to minimize friction as the article **50** moves across the cover **32**. In an embodiment, the housing **30** surrounds the upper and lower vortex generators **12**, **16**, or at least the upper vortex generator **12**. Additionally, each vortex suction unit **10** may also be provided with its own modular controller **62** which is functionally coupled with the motor **20** and/or the belt drive **44** to control the speed of the vortex suction unit **10** and belts **40** by varying power levels provided thereto. Further, each individual modular controller **62** may also be functionally coupled to a main controller **60** which, for example, is able to provide various signals to first and second vortex suction units **10a** and **10b** so as to move their respective motors **20** or belts **40** at different speeds depending on, for example, the desired attraction force, conveyance speed, positioning of the article **50** and predetermined transfer path TP.

Each vortex suction unit **10** may also be provided with its own means for rotation, such as a rotation motor **52** connected to a crown gear **54** disposed on a rear surface of the vortex suction unit **10**. The rotation motor **52** is attached to a support **56** which is fixed at one end and at the other end is rotatably connected to the vortex suction unit **10** at the axis of rotation of the motor **20**. The main controller **60**, directly through control lines **64** or through a modular controller **62**, provides power to the rotation motor **52** in order to rotate the crown gear **54** and position a vortex suction unit **10** at a particular alignment angle α . Further, the angular rotation of individual vortex suction units **10**, which may be provided for both vertically and horizontally, can provide for numerous different, complex transfer paths TP in three-dimensions, and also allows for quick adjustments in transfer paths TP and for changes in alignment of articles **50** therein. For example, such rotatable vortex suction units **10** could be rotated before and or while holding an article **50** to distribute it to various conveyors **80** or belts **40** of other vortex suction units **10** disposed horizontally at angles to its own belts **40** and/or positioned vertically above or below.

Additionally, vortex suction units **10** provided with individual belts and/or rotation means may be used to align an article **50**, for example, to an alignment edge **58** of a conveyor **80**. The vortex suction units **10** are rotated to or disposed at an alignment angle α directed toward the alignment edge **58** to translate an article **50** from its position at an input traction rollers **46a** and align it to the alignment edge **58** before exiting through the output traction rollers **46b**. Alternatively or additionally, one row of vortex suction units **10** could be part of a

first array **70a** and a parallel row of vortex suction units **10** could be part of a second array **70b**. In such a case, the controller **60** would be able to rotate the vortex suction units **10** of the first array **70a** to the alignment angle α and/or drive their belts **40** at higher speeds than those of the vortex suction units **10** of the second array **70b** to align the articles **50**.

Referring to FIGS. 11 and 12, examples of conveyance systems **100** using vortex suction units **10** to handle double-picks, or multiple overlapping articles in the transfer path, are shown. First and second arrays **70a**, **70b** are arranged in parallel and facing one another. Referring to FIG. 11, as overlapping first and second articles **50a**, **50b** travel upwards along the transfer path TP on the vertical conveyor **84**, the second article **50b** will start to peel away from the first article **50a**. An air knife **90** may provide a tangential air stream to facilitate the separation of the first and second articles **50a**, **50b**. The vortex suction units **10** of the first and second arrays **70a**, **70b** may be provided an increasing or decreasing attraction force **A** in the direction of the transfer path P. For example, the vortex suction units **10** at the lower end of the first array **70a** may have a smaller attraction force **A** to ensure that an overlapping second article **50b** will start to separate from the first article **50a**. Additionally, as the second article **50b** nears the vortex suction units **10** of the second array **70b**, the air flow will become hindered, causing current to decrease and rpm to increase, at which point additional power may be provided to one or more of the vortex suction units of the second array. The conveyance system **100** of FIG. 12 is similar to that of FIG. 11, except that gravitational force aids in the separation of the second article **50b** and that a stacking container **94** and a double-pick container **92** are provided for sorting first and second articles **50a**, **50b**, respectively. Further, the vortex suction units **10** above the stacking container may be sequentially slowed and/or disengaged so as to provide a gradual release of the article **50**.

Referring to FIG. 13, a conveyor **80** includes vortex suction units **10** which adhere to the articles **50** and move them along the transfer path TP. The vortex suction units **10** are mechanically and/or electrically connected to a guide **38** which travels in the direction of the transfer path TP. The guide **38** may be belts **40** or other conveyance means for moving the vortex suction units **10** in the direction of the transfer path TP. For example, a belt drive **44** can be used to drive one or more traction rollers **46** moving one or more belts **40** to which the vortex suction units **10** are attached. Additionally, the traction rollers **46** and the inside surfaces of the belts **40** may each be formed from a conductive material and electrically connected to the vortex suction units **10** to rout power thereto from a controller **60** or power source. The controller **60** may also be used to drive the belt drive **44** at various speeds and/or to adjust the power level at individual vortex suction units **10**. While the conveyor **80** shown in FIG. 13 is an elevator conveyor which flips an article **50** from input I to output O, movable vortex suction units **10** traveling with or along a guide **38** in the direction of the transfer path TP may be provided in any type of conveyance system **100** alone or in combination with stationary vortex suction units **10**.

Referring to FIG. 14, a conveyance system **100** which is also effective for flipping an article **50** provides the article **50** through a deflector **88** and input roller **46a** to a horizontal conveyor **82** having vortex suction units **10**. The article is then directed to an inclined conveyor **83** after being flipped by a deflector **88** having a radius of curvature **r**. The inclined conveyor **83** then carries the flipped article out through output roller **46b**. A controller **60** may be provided to control the respective belt speeds of conveyors **82**, **83** and the speed of each of their respective vortex suction units **10**.

Referring to FIG. 23, a conveyance system 100 having first and second conveying devices 80a, 80b with first and second vortex suction units 10a, 10b, is shown. As an article 50 moves along the transfer path TP between the first and second vortex suction units 10a, 10b, the main controller 60 selectively engages a respective one of the first and second suction units 10a, 10b to adhere the article 50 thereto. In the embodiment shown, the first conveying device 80a is a mechanical-guide conveyor which moves the first vortex suction unit 10a along a first secondary path TP1 extending from Position A1 in the transfer path TP to Position A2 at a first stacking container 94a. The second conveying device 80b is likewise a mechanical-guide conveyor which moves the second vortex suction unit 10b along a second secondary path TP2 extending from Position B1 in the transfer path TP to Position B2 at a second stacking container 94b. Mechanical-guide conveyors may use rollers 112 movable along rails 114 and/or drive gears 116 meshing with teeth 118. Further, the rollers 112 or the drive gears 116 connected with the vortex suction units 10 may also be coupled with the belt drives 44 thereof, or could be directly connected to the controller 60, to control speed and direction. Likewise, the first and second conveying devices 80a, 80b may utilize belts 40 respectively attached to the first and second vortex suction units 10a, 10b as in FIG. 13, which are bidirectional.

For example, where the article 50 is printed paper, it is adhered to either the first vortex suction unit 10a or the second vortex suction unit 10b depending on which side of the paper contains ink. When a first article 50a has printing on a first side, the controller 60 switches on or speeds up the first vortex suction unit 10a which then travels along the first secondary path TP1 to the first stacking container 94a, into which the first article 50a is dropped once the ink has dried. Similarly, when a second article 50b is printed on the opposite side, the controller 60 switches on or speeds up the second vortex suction unit 10b which then travels along the second secondary path TP2 to the second stacking container 94b, into which the second article 50b is dropped once the ink has dried.

FIGS. 15 and 16 are schematic representations of different control schemes which may be provided to individual vortex suction units 10 of a conveyance system 100 through a main controller 60. The controller 60 may control individual vortex suction units 10 separately or in groups. When an article 50 is positioned in the low pressure region LP of a vortex suction unit 10, the air flow is hindered causing the current (i) to decrease and the speed (rpm) to increase compared to idle conditions. Thus, the current level and/or speed may be used as an indicator that a substrate is present adjacent a vortex suction unit 10, in other words, that a low pressure condition exists. Since the vortex suction unit 10-A is not covered by an article 50 as indicated to the controller 60 by a relatively high current and low speed, it may be switched off. Vortex suction units 10-B and 10-C are actively maintained in operation by the controller 60 since the article 50 is hindering air flow and causing the controller 60 to recognize a relatively low current and high speed. Further, the controller 60 recognizes that the subsequently arranged vortex suction unit 10-D will need to be switched on as it is next in the sequence. Once the article 50 is covering the vortex suction unit 10-D, vortex suction unit 10-B can be switched off and so on. The timing of such provident triggering of sequentially arranged vortex suction units 10-A through E by the controller 60 may be determined in accordance with a predetermined conveyance speed, the speed at which the controller 60 drives belts 40 and/or by relative changes in current or speed as the article 50 moves past individual vortex suction units 10. Because vortex suction units 10 are relatively small and lightweight, they may be

shut off and activated relatively quickly. Thus, a consistent adherence may be applied efficiently since only vortex suction units 10 carrying an article 50 are active.

Alternatively or additionally, the controller 60 may provide different power levels to the motors 20 of the sequentially arranged vortex suction units 10-A through E so as to drive them at different speeds and thereby provide various magnitudes of an attraction force A. For example, the controller 60 could provide decreasing speeds to the sequentially arranged vortex suction units 10-A through E carrying an article 50 along a transfer path TP against the force of gravity. Heavier articles 50 will fall away sooner than lighter articles 50 because of the decreasing attraction force A. Thus, a sorting function may be obtained using deflectors 88 or sorting bins arranged in sequence to capture different articles 50a, 50b, 50c of various type, weight and/or size.

Referring to FIGS. 19-22, the controller 60 for at least first and second vortex suction units 10a, 10b may be provided externally (FIGS. 19 and 21) or with one of the vortex suction units 10 (FIG. 20). The controller 60 provides power to the vortex suction units 10 either directly or through a modular controller 62 and senses current and speed. Additionally, the controller 60 may also power the belts 40, which may be common (FIG. 21) or provided for each vortex suction unit 10 (FIGS. 19 and 20), and control the direction thereof by switching the rotation of the belt drive 44.

A control system 110 includes a main controller 60, and optionally includes modular controllers 62 for individual vortex suction units 10. The main controller 60 and the modular controllers 62 may include one or more sub-controllers 66, which may be, for example microcontroller Model No. ATMEGA88P manufactured by ATMEL Corp. Further, the main controller 60 and the modular controllers 62 may include communication interfaces 67 connected through control lines 64 for data exchange. The communication interfaces 67 may be, for example, Control Area Network (CAN) controllers Model No. MCP2515 manufactured by Microchip Technology Inc. which communicate with the controllers 60, 62 through a standard Serial Peripheral Interface (SPI) and the control lines 64 may be a CAN bus system or a communication system using the RS-485 communication standard.

The main controller 60, which may be, for example, controller Model No. AT90CAN128 manufactured by ATMEL Corp., is provided to control the speed of belt drives 44, rotation motors 52 and/or the motors 20 of individual suction units 10 either directly or through modular controllers 62. The modular controllers 62 may include motor controllers 68 which may be, for example, control chip Model No. NJM 2673 manufactured by New Japan Radio Co., Ltd. for stepper motors or control chip Model No. EBL-H-50-03-05 manufactured by Portescap for brushless DC motors. In an embodiment, the belt drives 44 and the rotation motors 52 are stepper motors and the motors 20 are brushless DC motors. Further, sensors 65 may be provided for measuring the speed (rpm) of the belt drive 44, rotation motor 52 and/or motor 20, and for transmitting such data as an encoded signal to the main controller 60 either directly or through the modular controllers 62. Other configurations of the control system 110, however, are also possible. For example, where the modular controllers 62 are not provided the motor controllers 68 may be provided with the main controller 60 or on individual suction units 10.

The articles 50 may be flat, flexible articles, such as paper or plastic sheets. However, other types of articles, such as boxes or containers of various shape may be carried by conveyance systems 100 using vortex suction units 10 according to the present invention.

While the invention has been particularly shown and described with reference to preferred embodiments thereof, it will be understood by those skilled in the art that various changes in form and details may be made therein without departing from the spirit and scope of the invention. Accordingly, the invention is to be limited only by the scope of the claims and their equivalents.

What is claimed is:

1. A method of conveying an article along a transfer path comprising:

disposing at least a first and a second vortex suction unit in sequence in a direction of the transfer path;

supporting the article relative to at least one of the vortex suction units using a conveyor;

determining a position of the article relative to the vortex suction units, using a controller, based on an air flow of at least one of the first and second vortex suction units being hindered by the position of the article relative to the vortex suction units;

controlling the vortex suction units so as to convey the article using the conveyor.

2. The method according to claim 1, further comprising disposing third and fourth vortex suction units in sequence in the direction of the transfer path, wherein the first and third vortex suction units are controlled together as a first array and the second and fourth vortex suction units are controlled together as a second array.

3. The method according to claim 1, wherein the controlling includes sequentially operating each vortex suction unit along the transfer path based on the determined positions of the article as the article moves along the transfer path.

4. The method according to claim 1, wherein the controlling is performed so as to control at least one of a speed of the conveying, a direction of the conveying, and an attraction force of the article to the conveyor.

5. The method according to claim 1, wherein the determining the position of the article includes determining, by the controller, at least one of a speed and a current of at least one of the first and second vortex suction modules.

6. The method according to claim 1, wherein the controlling includes a provided triggering of sequentially arranged vortex suction units along the transfer path based on relative changes in at least one of a speed and a current of the sequentially arranged vortex suction units.

7. The method according to claim 1, further comprising aligning the article to an alignment edge using at least one of different belt speeds of the conveying devices and a rotation of at least one of the vortex suction units.

8. The method according to claim 1, wherein the determining the position of the article is performed without using an external sensor.

9. The method according to claim 1, wherein the determining the position of the article is performed by the controller measuring at least one of a speed and a current of the vortex suction modules.

10. The method according to claim 9, wherein the controlling is performed by the controller separately operating the vortex suction modules sequentially along the transfer path.

11. The method according to claim 1, further comprising operating the first and second vortex suction modules at different speeds.

12. The method according to claim 1, wherein the determining the position of the article further comprises using the controller to determine whether the air flow of a third vortex suction unit, disposed sequentially along the transfer path after the first and second vortex suction units, is also being hindered by the position of the article.

* * * * *