



US00D720048S

(12) **United States Design Patent**
Winborn

(10) **Patent No.:** **US D720,048 S**

(45) **Date of Patent:** **** Dec. 23, 2014**

(54) **MULTI-PORT VALVE**

(71) Applicant: **Craig V. Winborn**, Odessa, TX (US)

(72) Inventor: **Craig V. Winborn**, Odessa, TX (US)

(**) Term: **14 Years**

(21) Appl. No.: **29/500,543**

(22) Filed: **Aug. 26, 2014**

(51) **LOC (10) Cl.** **23-01**

(52) **U.S. Cl.**
USPC **D23/233**

(58) **Field of Classification Search**

CPC E03B 9/16; E03B 9/04; E03B 9/14;
E03B 9/20; F16K 27/006; F16K 15/188;
F16K 15/181

USPC D23/233-237, 244-249; 137/299, 300,
137/138, 218, 594, 318

See application file for complete search history.

(56) **References Cited**

U.S. PATENT DOCUMENTS

D522,616 S *	6/2006	Minnick et al.	D23/233
D620,553 S *	7/2010	Li et al.	D23/233
D635,644 S *	4/2011	Yamada	D23/233
D637,270 S *	5/2011	Nicolia et al.	D23/235
D667,082 S *	9/2012	Fukushima	D23/235
D678,981 S *	3/2013	Shengyong	D23/233
D690,800 S *	10/2013	Ren	D23/233

D705,396 S *	5/2014	Roden	D23/233
D705,901 S *	5/2014	Johnson	D23/233
D714,910 S *	10/2014	Roden	D23/233

* cited by examiner

Primary Examiner — Cynthia Ramirez

(74) *Attorney, Agent, or Firm* — Sarah Hegi Simpson;
McWhorter, Cobb & Johnson, LLP

(57) **CLAIM**

I claim the ornamental design for a multi-port valve, as shown and described.

DESCRIPTION

FIG. 1 is a top perspective view of a multi-port valve showing my new design;

FIG. 2 is a top front perspective view of the multi-port valve of FIG. 1;

FIG. 3 is a front perspective view of the multi-port valve of FIG. 1;

FIG. 4 is a side perspective view of the multi-port valve of FIG. 1;

FIG. 5 is a rear perspective view of the multi-port valve of FIG. 1; and,

FIG. 6 is a top rear perspective view of the multi-port valve of FIG. 1.

The broken line showing in the figures is included for the purpose of illustrating portions of the multi-port valve and forms no part of the claimed design.

1 Claim, 6 Drawing Sheets

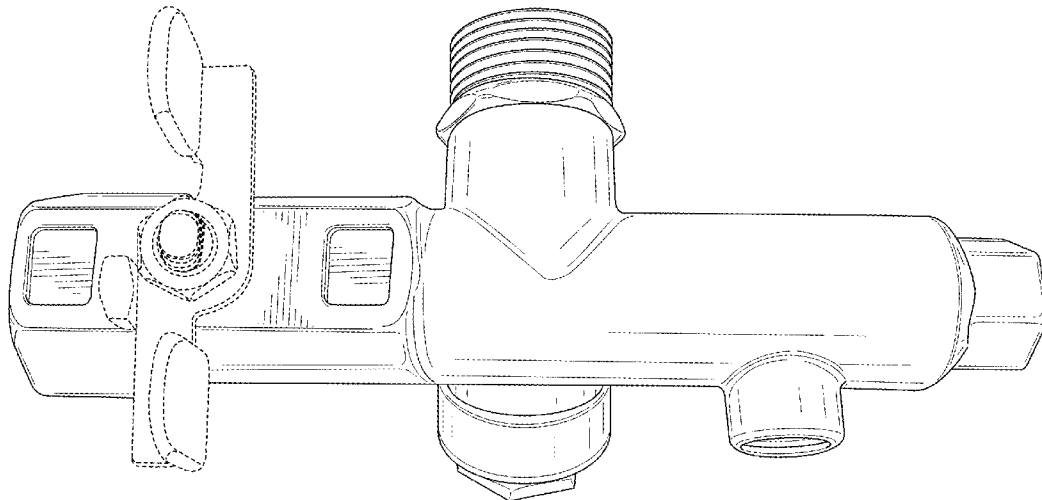

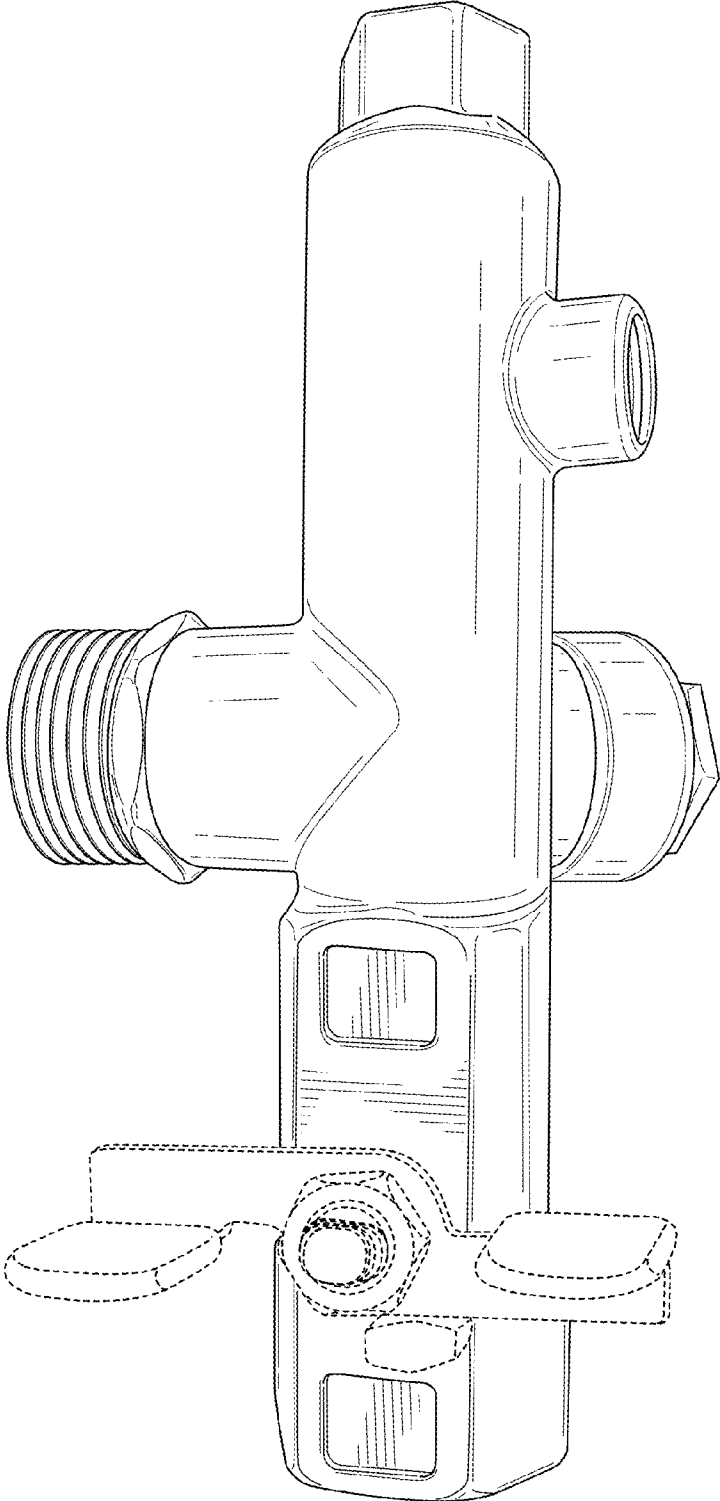

FIG. 1

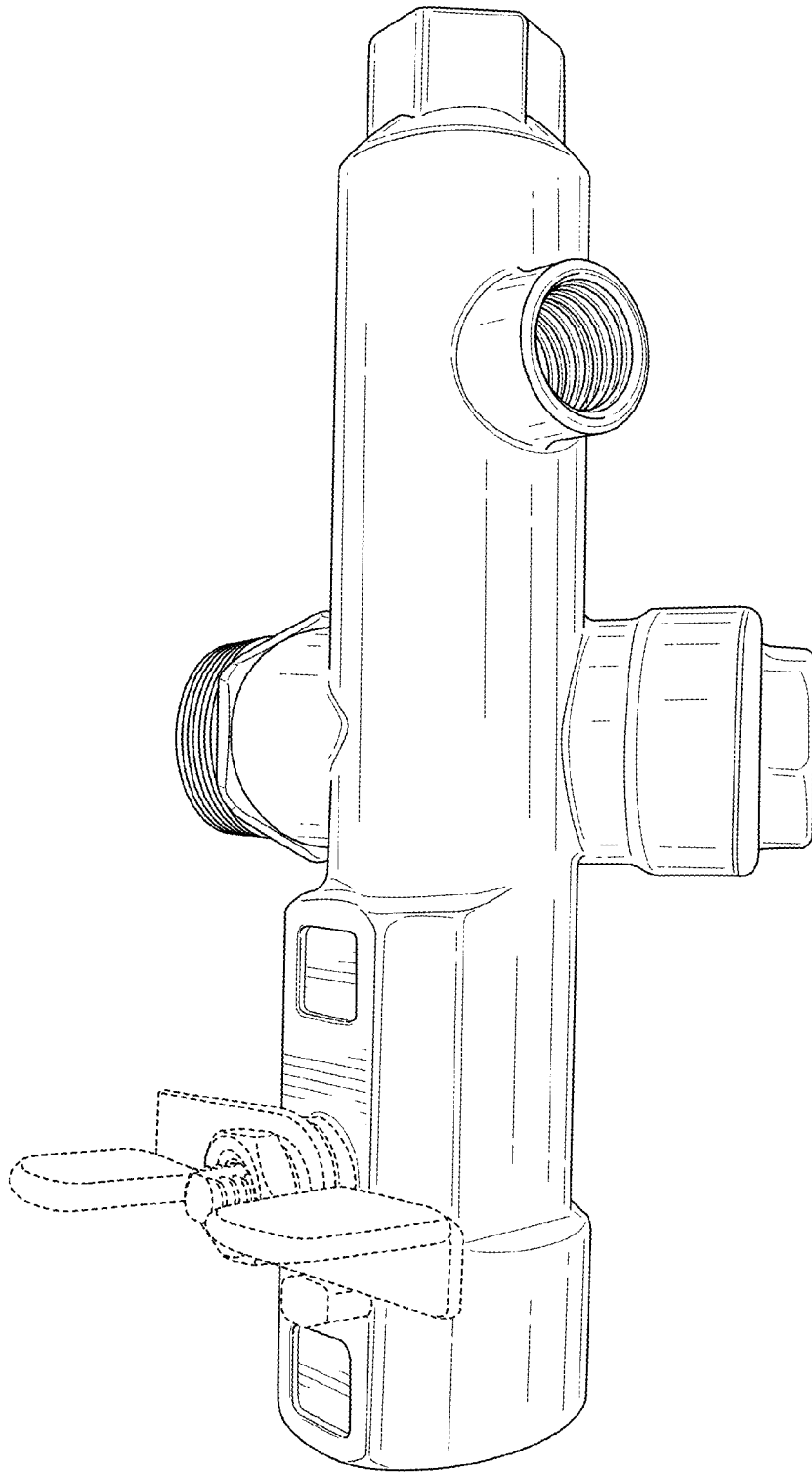

FIG. 2

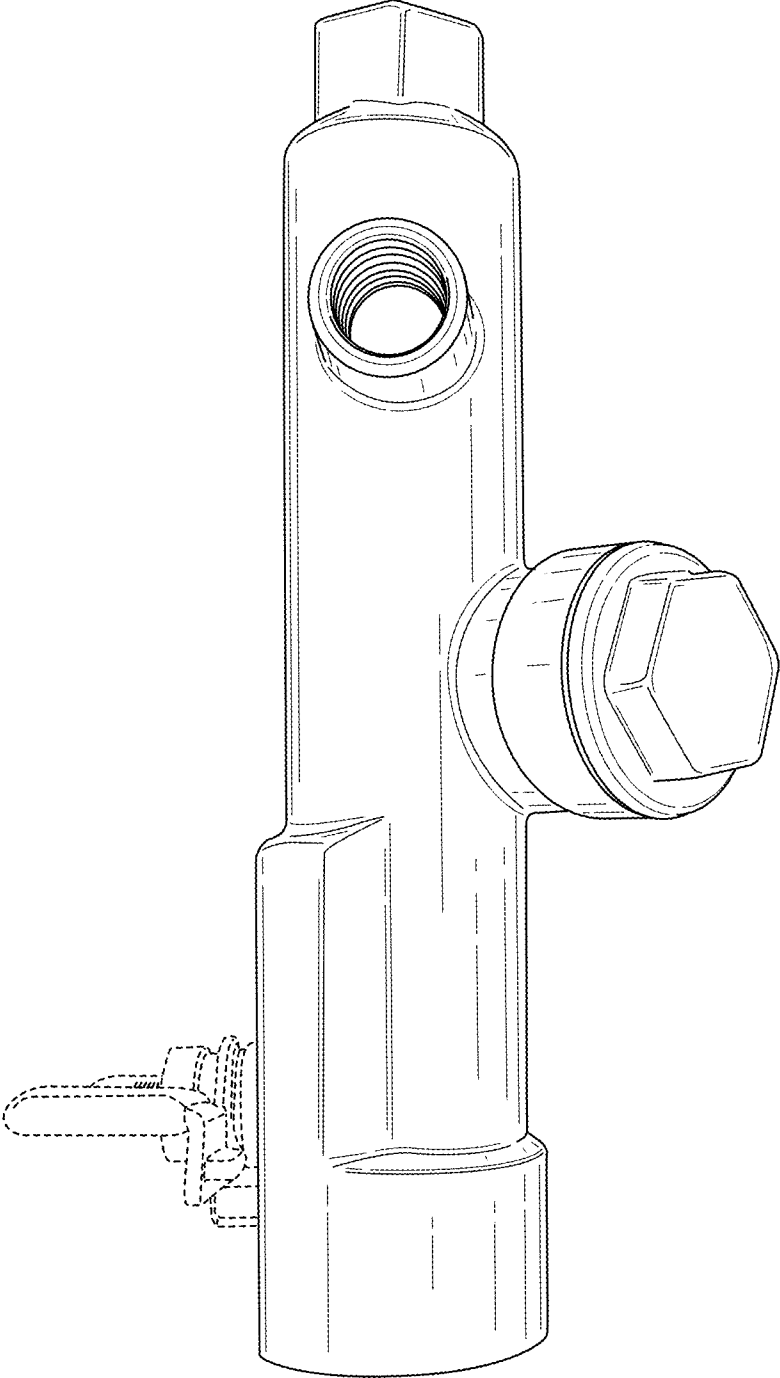

FIG. 3

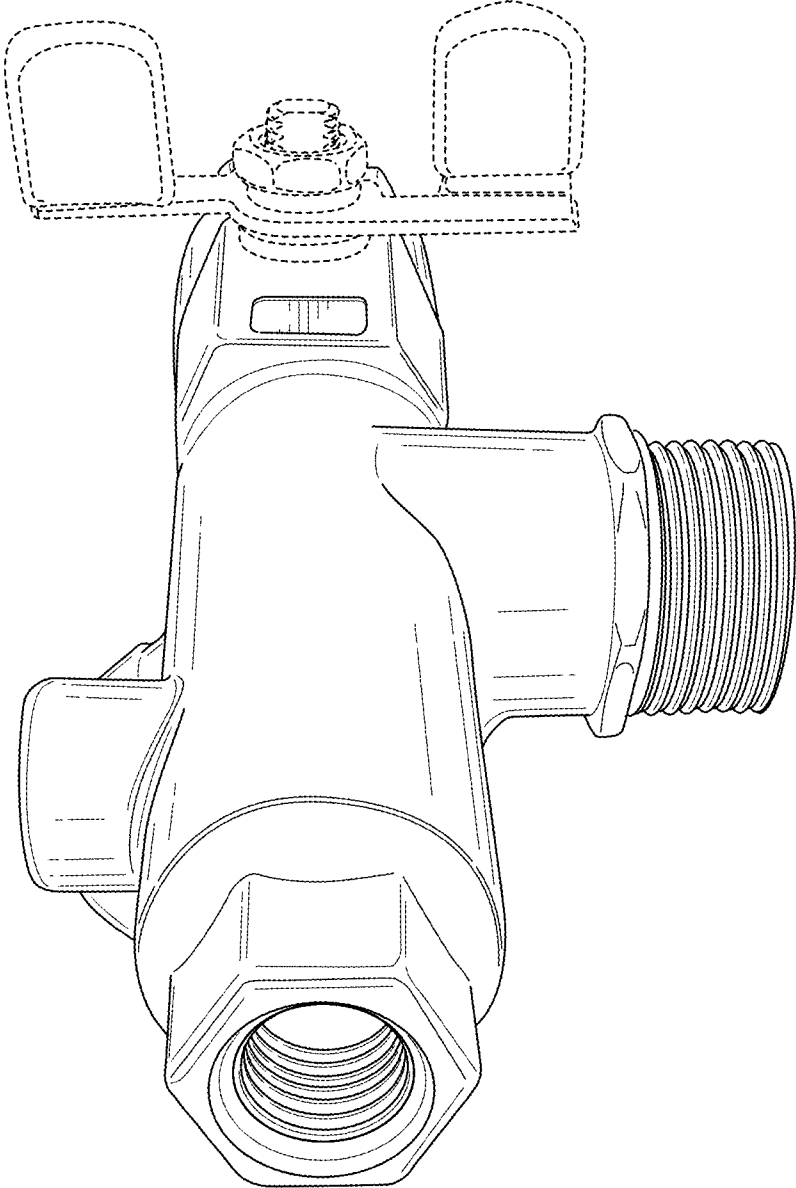

FIG. 4

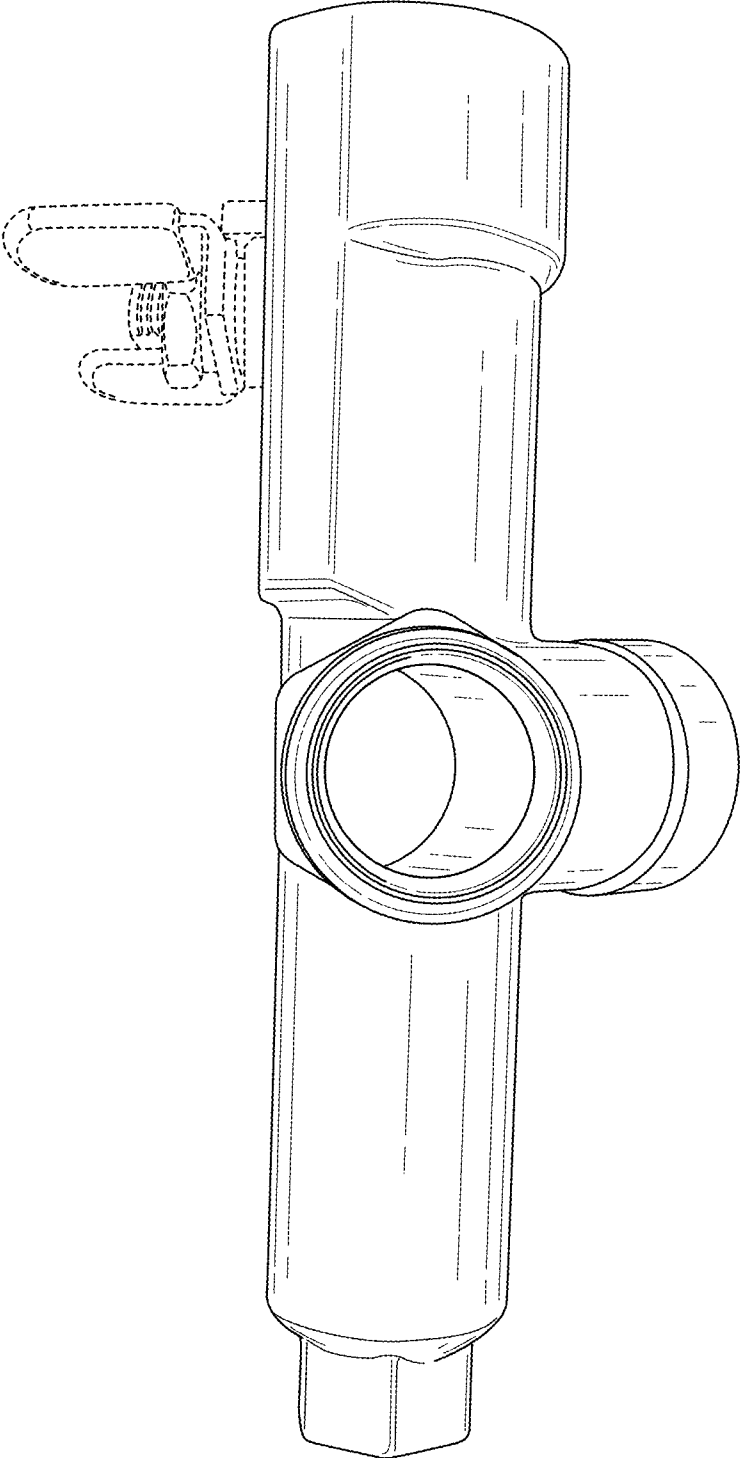

FIG. 5

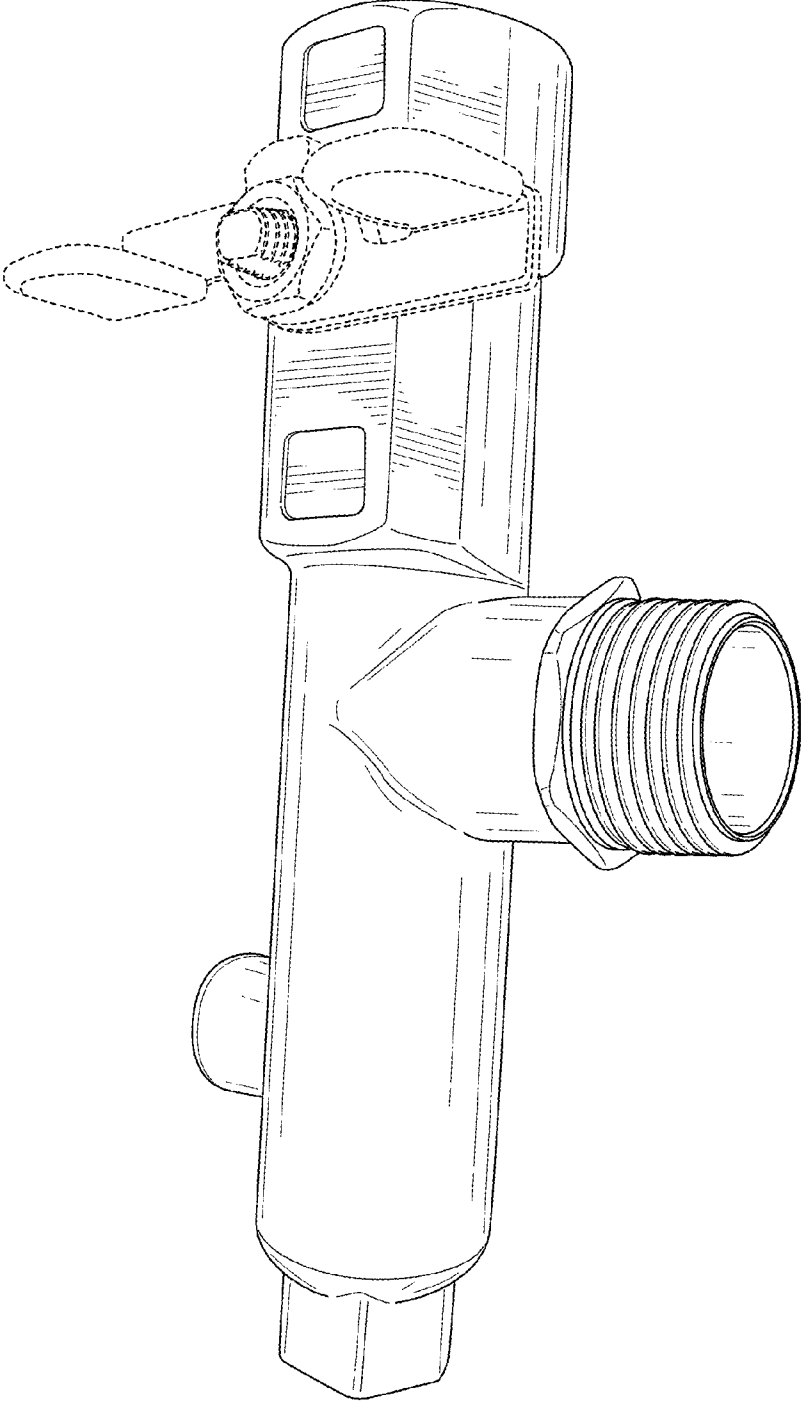

FIG. 6