

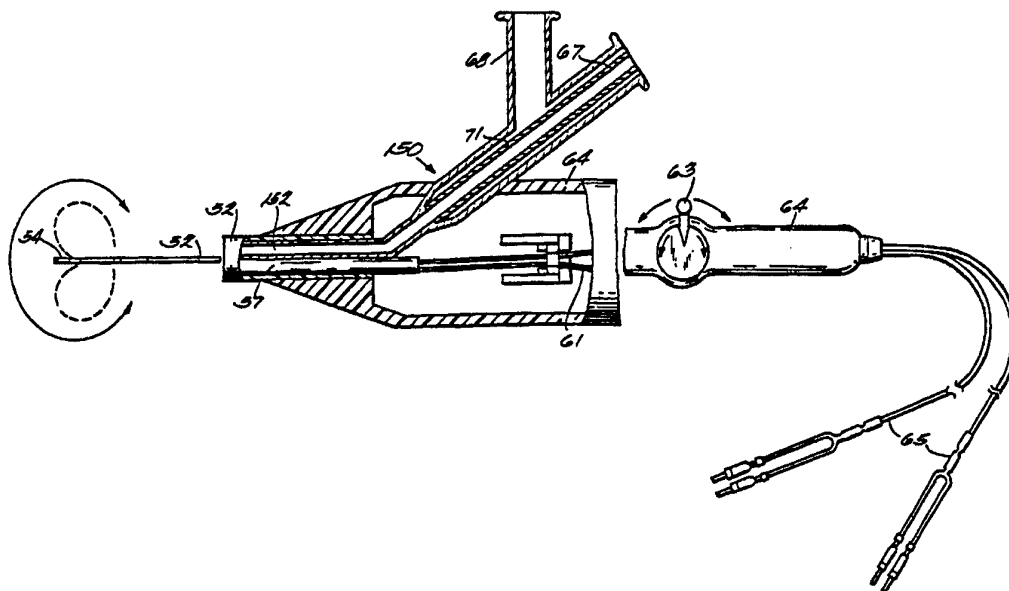

INTERNATIONAL APPLICATION PUBLISHED UNDER THE PATENT COOPERATION TREATY (PCT)

(51) International Patent Classification ⁶ : A61M 37/00	A1	(11) International Publication Number: WO 96/40356									
		(43) International Publication Date: 19 December 1996 (19.12.96)									
<p>(21) International Application Number: PCT/US96/09600</p> <p>(22) International Filing Date: 7 June 1996 (07.06.96)</p> <p>(30) Priority Data:</p> <table border="0"> <tr> <td>08/480,200</td> <td>7 June 1995 (07.06.95)</td> <td>US</td> </tr> <tr> <td>08/481,887</td> <td>7 June 1995 (07.06.95)</td> <td>US</td> </tr> <tr> <td>08/483,991</td> <td>7 June 1995 (07.06.95)</td> <td>US</td> </tr> </table> <p>(71) Applicant: EP TECHNOLOGIES, INC. [US/US]; 350 Potrero Avenue, Sunnyvale, CA 94086 (US).</p> <p>(72) Inventors: WHAYNE, James, G.; 17930 Los Felice Road, Saratoga, CA 95070 (US). FLEISCHMAN, Sidney, D.; 855 Woodland Avenue, Menlo Park, CA 94025 (US). SWANSON, David, K.; 877 Heatherstone Way, Mountain View, CA 94040 (US). BOURNE, Thomas, M.; 2640 California Street, No. 96, Mountain View, CA 94040 (US). OWENS, Patrick, M.; 10380 N. Walnut Circle, No. 4, Cupertino, CA 95014 (US).</p> <p>(74) Agents: RYAN, Daniel, D. et al.; 633 West Wisconsin Avenue, Milwaukee, WI 53203 (US).</p>	08/480,200	7 June 1995 (07.06.95)	US	08/481,887	7 June 1995 (07.06.95)	US	08/483,991	7 June 1995 (07.06.95)	US	<p>(81) Designated States: CA, JP, European patent (AT, BE, CH, DE, DK, ES, FI, FR, GB, GR, IE, IT, LU, MC, NL, PT, SE).</p> <p>Published <i>With international search report.</i></p>	
08/480,200	7 June 1995 (07.06.95)	US									
08/481,887	7 June 1995 (07.06.95)	US									
08/483,991	7 June 1995 (07.06.95)	US									

(54) Title: ATRIAL APPENDAGE STASIS REDUCTION PROCEDURES AND DEVICES



(57) Abstract

Devices and procedures are shown for non-surgically repositioning an atrial appendage (17) using a grasping catheter (40), and for affixing the appendage in the new position, thereby minimizing thrombus formation, especially for patients with atrial fibrillation.

FOR THE PURPOSES OF INFORMATION ONLY

Codes used to identify States party to the PCT on the front pages of pamphlets publishing international applications under the PCT.

AM	Armenia	GB	United Kingdom	MW	Malawi
AT	Austria	GE	Georgia	MX	Mexico
AU	Australia	GN	Guinea	NE	Niger
BB	Barbados	GR	Greece	NL	Netherlands
BE	Belgium	HU	Hungary	NO	Norway
BF	Burkina Faso	IE	Ireland	NZ	New Zealand
BG	Bulgaria	IT	Italy	PL	Poland
BJ	Benin	JP	Japan	PT	Portugal
BR	Brazil	KE	Kenya	RO	Romania
BY	Belarus	KG	Kyrgystan	RU	Russian Federation
CA	Canada	KP	Democratic People's Republic of Korea	SD	Sudan
CF	Central African Republic	KR	Republic of Korea	SE	Sweden
CG	Congo	KZ	Kazakhstan	SG	Singapore
CH	Switzerland	LI	Liechtenstein	SI	Slovenia
CI	Côte d'Ivoire	LR	Liberia	SK	Slovakia
CM	Cameroon	LT	Lithuania	SN	Senegal
CN	China	LU	Luxembourg	SZ	Swaziland
CS	Czechoslovakia	LV	Latvia	TD	Chad
CZ	Czech Republic	MC	Monaco	TG	Togo
DE	Germany	MD	Republic of Moldova	TJ	Tajikistan
DK	Denmark	MG	Madagascar	TT	Trinidad and Tobago
EE	Estonia	ML	Mali	UA	Ukraine
ES	Spain	MN	Mongolia	UG	Uganda
FI	Finland	MR	Mauritania	US	United States of America
FR	France			UZ	Uzbekistan
GA	Gabon			VN	Viet Nam

**ATRIAL APPENDAGE STASIS REDUCTION
PROCEDURES AND DEVICES**

Field of the Invention

5 This invention relates to the reduction of
regions of blood stasis and ultimately thrombus
formation in such regions, particularly in the
atrial appendages for patients with atrial fibril-
lation. More specifically, the invention relates to
procedures and devices for affixing the atrial ap-
pendages in an orientation that reduces subsequent
10 formation of thrombus.

Background of the Invention

15 The atria must enable organized electrical
propagation from the SA Node to the AV Node to
stimulate the atria to contract in an organized way
to transport blood from the atria to the ventricles,
and to provide timed stimulation of the ventricles.
The atrial appendages are especially important in
the transport of blood because they have a sack-like
20 geometry with a neck potentially more narrow than
the pouch. In this case, contraction of the
appendage is essential to maintain an average
absolute blood velocity high enough to eliminate
potential stasis regions which may lead to thrombus
25 formation.

Atrial fibrillation and abnormalities which
may lead to atrial fibrillation (such as mitral
and/or tricuspid regurgitation) are often associated
with abnormal electrical propagation through the
30 heart leading to inefficient transport of blood in

certain regions of the atria, and/or an enlargement of one or both atria to up to 2-3 times the normal size.

5 Heretofore, atrial fibrillation has often
been treated either by administration of drugs or
through surgical procedures, for example, procedures
which surgically create a maze pattern in the atria
which reduces the probability of fibrillation. The
10 typical access points into the interior of the atria
during a surgical procedure are the atrial
appendages. Therefore, at the conclusion of the
surgical procedure, the region occupied by the
atrial appendages is eliminated by surgically
15 removing the appendages. This mitigates subsequent
problems resulting from blood stasis in the atrial
appendages as well as from electrical isolation of
the appendages from the rest of the atria .

More recently, maze-like procedures have
been developed utilizing catheters which may create
20 long thin lesions to effectively create a maze for
electrical conduction in a predetermined path.
However, such minimally invasive procedures may
result in regions of continued blood stasis,
particularly in the atrial appendages due to
25 electrical isolation of the appendages or decreased
contractility of the tissue due to the destruction
of large regions of atrial tissue. Also, the
response of the atria to permanent conversion from
atrial fibrillation to sinus rhythm after a
30 catheter-based and/or surgical maze procedure has
not been proven to return appendage function to
normal.

Since such catheterization procedures do
not admit themselves to surgical removal of the
35 appendages, a need has developed for procedures and

devices which reduce stasis regions to effectively minimize subsequent thrombus formation within the appendages. Specifically, procedures and devices which reposition the atrial appendages and affix them in the altered position to reduce stasis regions and ultimately thrombus formation would be desirable.

Summary of the Invention

An important aspect of the invention involves providing methods and devices to reposition the atrial appendages, for example by inversion thereof either totally or partially. In accordance with this aspect of the invention, several embodiments of devices are provided for grabbing or otherwise attaching themselves to an appendage wall and either inverting or otherwise pulling the walls of the appendage together to reduce the size of the region of potential blood stasis, and consequently the effective volume of the affected atrium. In accordance with this aspect, it is an object of the invention to reduce the region of potentially static blood and, hence the thrombogenicity of the atrium.

Further objects and advantages of the invention will become apparent from the following detailed description, the claims and the accompanying drawings.

Brief Description of the Drawings

FIGURE 1 is a fragmentary view, with parts in section, illustrating introduction of a catheter into the right atrium of a heart in accordance with the invention;

FIGURE 2 is a fragmentary view, with parts in section, showing introduction of a catheter into the right atrium of the heart via the femoral vein;

FIGURE 3 is a fragmentary view showing the right atrium with the catheter introduced therein and with the right atrial appendage inverted;

5 FIGURE 4 is a fragmentary view of the left atrium, with parts in section, illustrating introduction of a catheter into the left atrial appendage via a retrograde procedure;

10 FIGURE 5 is a fragmentary view, with parts in section, showing positioning of a catheter on the endocardial surface of a left atrial appendage using a transeptal procedure;

FIGURE 6 shows introduction of a catheter via a transeptal approach for inversion of the left atrial appendage;

15 FIGURE 7 is a side view illustrating a helical coil attaching catheter used in connection with the invention;

20 FIGURE 8 is a sectional view illustrating a helical coil catheter with an independently rotatable hollow coil assembly with a lumen extending therethrough;

25 FIGURE 9 is a sectional view showing the insertion of the helical coil catheter in FIGURE 7 into the myocardium to provide a focal point for pulling the appendage;

FIGURE 10 illustrates the inversion of the appendage wall shown in FIGURE 9 utilizing the catheter helical coil assembly shown in FIGURE 7;

30 FIGURE 11 is a fragmentary view showing the introduction through the helical coil assembly of FIGURE 7 of a marking contrast material;

FIGURE 12A is a sectional view of a catheter distal tip employing a three prong attaching catheter;

35 FIGURE 12B is a sectional view of a

catheter similar to that shown in FIGURE 12A except that the prongs extend radially outward;

FIGURE 13 is a fragmentary view illustrating attachment of the catheter of FIGURE 12A to an appendage wall;

FIGURE 14 is a fragmentary view illustrating use of the catheter of FIGURE 12A for inversion of an appendage wall;

FIGURE 15 is a fragmentary view of the distal tip of the catheter of FIGURE 12A retracted into a protective sheath;

FIGURE 16A is a fragmentary side view of a catheter distal section illustrating a hollow needle incorporating an internal extending, expandable type attachment/pulling element;

FIGURE 16B is a side view of the attachment/pulling element of FIGURE 16A in an expanded configuration;

FIGURE 17 is a fragmentary view illustrating another attachment/pulling element configuration which may be used to provide an attachment point with which to invert an atrial appendage;

FIGURE 18 is a fragmentary view showing a catheter distal tip carrying a compound loop device;

FIGURE 19A illustrates an inverting catheter used in conjunction with a compound loop support catheter;

FIGURE 19B is a fragmentary side view illustrating the inversion of an atrial appendage utilizing the devices shown in FIGURE 19A;

FIGURE 20 is a fragmentary side view showing the use of a grasping catheter of the general type shown in FIGURE 12A in conjunction with a lasso catheter for maintaining the walls of the

inverted appendage together;

FIGURES 21 and 22A are fragmentary views of the combination shown in FIGURE 20 illustrating further steps of tying the appendages in an inverted orientation;

FIGURE 22B is a schematic showing one embodiment of a tying mechanism for use in the lasso catheter of FIGURES 20-22A;

FIGURES 23 and 24A are fragmentary views illustrating the use of a catheter of the general type shown in FIGURE 7 in conjunction with a releasable lasso catheter and showing the introduction of a biocompatible adhesive/filler material into the space outside of the inverted appendage;

FIGURE 24B is a fragmentary view showing the withdrawal of a catheter of the type shown in FIGURE 7 after affixing in place an inverted appendage with a stabilizing filler material;

FIGURE 25 is a fragmentary sectional view showing a catheter with dual infusion ports for introduction of fluid materials;

FIGURE 26 is a fragmentary view showing the use of a further embodiment of a lasso catheter, which is made of a metallic coil or other electrical conductor and is connected to an RF Generator for use in thermally fusing the appendage walls;

FIGURE 27A is a fragmentary view showing the application over an inverted appendage of a metallic mesh;

FIGURES 27B and 27C are fragmentary sectional views of a catheter mechanism used to expand the metallic mesh during insertion over the inverted appendage;

FIGURE 28 is a fragmentary sectional view

showing the insertion of a helical metallic winding made from a memory transitional material which upon introduction through the appendage expands or contracts to its original form at body temperature and holds the appendage in place;

5

FIGURE 29 is a sectional view of a catheter containing an expandable anchor for insertion into an inverted appendage;

10

FIGURE 30 is a cross-sectional view taken along 30-30 of FIGURE 29;

FIGURE 31A is a cross-sectional view of an appendage showing the use of insertable expandable anchors in conjunction with a draw string;

15

FIGURE 31B is a cross-sectional view showing the appendage of FIGURE 31A after it has been drawn together;

FIGURE 31C is a cross-sectional view showing a single expandable anchor inserted into an appendage wall;

20

FIGURE 32A is a sectional view of a catheter containing an alternative type of expandable anchor for insertion into an inverted appendage;

25

FIGURE 32B is a cross-sectional view showing a single expandable anchor of the type shown in FIGURE 32A inserted into an appendage wall;

30

FIGURE 33A is a side view of a handle mechanism for a catheter with a fixed hollow needle and an access point for an internal stylet mechanism;

FIGURE 33B is a side view of a handle mechanism for a catheter with a moveable hollow needle and an access point for an internal stylet mechanism;

35

FIGURE 34 is a fragmentary view, with parts

in section, illustrating introduction of a catheter into pericardium by means of a thoracostomy in accordance with the invention; and,

5 FIGURE 35 is an enlarged fragmentary view, with parts in section, of one embodiment of a catheter usable in the procedure shown in FIGURE 34.

Detailed Description of the Illustrated Embodiments

10 Referring more specifically to the drawings, FIGURES 1-3 show, in fragmentary fashion, the right atrium 10, the superior vena cava 12, the inferior vena cava 13, the ascending aorta 14, the right atrial appendage 16, the membranous septum 18, the right atrial freewall 20, the tricuspid valve 22, the opening of the coronary sinus 24, the valve of the coronary sinus 26, and the fossa ovalis 28.

15 A left atrium 11 is shown in FIGURES 4-6. There are also seen therein the aortic valve 15, the left atrial appendage 17, the left superior pulmonary vein 19, the mitral valve 21, and the left ventricle 32.

20 A catheter 40 is shown generally being introduced into the atria of a heart through various cardiovascular introduction passageways as will be discussed hereinafter. The point of attachment of catheter 40 to the wall of an atrial appendage 16 or 17 is indicated generally at 42.

25 Referring to FIGURES 1-6, various ways of entering a heart chamber and positioning a catheter tip on the interior wall of the atrial appendages are illustrated. In FIGURE 1, a catheter 40 is shown being advanced through the jugular vein past the superior vena cava 12 and into the right atrium 10 where it is steered so the tip is positioned on the endocardial surface of the right atrial appendage 16 where attachment is made. FIGURE 2

30

35

illustrates a procedure for introducing the catheter 40 through the femoral vein into the right atrium 10 and then into the right atrial appendage 16. FIGURE 3 illustrates the inversion of the right atrial appendage 16 using the catheter 40 introduced as shown in FIGURE 2.

FIGURE 4 illustrates the positioning of a catheter distal tip at a point 42 on the endocardial surface of the left atrial appendage 17 utilizing a retrograde procedure. A sheath with a preformed configuration may be required to maneuver the catheter tip down through the aorta 14 and up through the mitral valve 21. In addition, such a sheath would provide additional support for maneuvering the tip of the catheter. FIGURE 5 shows positioning of a catheter tip at a point 42 on the endocardial surface of the left atrial appendage 17 utilizing a transeptal introduction. Transeptal introduction is achieved by inserting an introducer or sheath with an internal dilator through the femoral or jugular vein and into the interior of the right atrium. Once in the right atrium, a long hollow needle with a preformed curve and a sharpened distal tip is introduced through the dilator and is forcibly inserted through the fossa ovalis 28. A radiopaque contrast material is injected through the needle to ensure the needle is in the left atrium as opposed to being in the pericardial space, aorta, or other undesired location. Once the position of the needle in the left atrium is confirmed, the dilator and sheath are advanced over the needle and into the left atrium. Then, the needle and dilator are removed leaving the sheath as an access point to the left atrium. FIGURE 6 shows the inversion of the left atrial appendage 17 after catheter 40 has been

attached at point 42 and by using a transeptal approach as shown in FIGURE 5. The use of such delivery systems as sheaths is shown in pending U.S. Application Serial No. 08/136,218, filed October 14, 1993, and entitled "Cardiac Mapping and Ablation Systems."

Methods & Devices for Repositioning Appendage Walls

Referring now to FIGURES 7-11, there is seen one type of catheter 50 provided for attachment of the distal tip thereof to the wall of an atrial appendage 16 or 17. The catheter 50 includes a catheter body 52 having a distal tip portion 54. In this embodiment a hollow coil 58 is attached to the catheter distal tip 54 and has a lumen 55 extending from the proximal end of the coil at the distal tip attachment point to the catheter handle assembly (not shown), The coil 58 is rotated by torquing the catheter body 52. The catheter body 52 may be provided with a steering mechanism 57, for example, of the type shown in Lundquist and Thompson U.S. Patent No. 5,254,088, which is incorporated herein by reference.

In the embodiment shown in FIGURE 8 the distal tip portion 54 of the catheter 50 is provided with an opening 56 through which the helically coiled distal tip element 58 can be advanced by rotation. Upon rotation of an inner supporting member 59 relative to catheter body 52, the distal helical tip portion 58 is rotated into the wall of atrial appendage 16 or 17. This opening 56 may constitute a single isolated hole which fits only the outer diameter of the helical coil assembly or a larger hole in the distal portion of the tip. An isolated hole provides support for the helical coil assembly during advancement and withdrawal as well

as providing a blunt surface masking the sharp distal tip needle 58 during manipulation of the catheter through the vasculature.

5 As shown in FIGURE 7, the helical coil may alternatively be permanently attached to the distal tip of the catheter thus requiring rotation of the catheter body 52 to screw the helical coil into or out of the tissue.

10 The distal tip of the helical element 58 is sharpened so that it has the capability of impaling the tissue wall. The rotatable supporting member 59 constitutes separate torque assembly that can be rotated manually from a point outside the body to cause rotation of element 59 relative to the
15 catheter body 52. This rotatable supporting member may be made of braided composite assembly such as stainless steel braid with polyamide, or a slotted hollow tube with an outer layer of shrink tubing. Once the helical coil assembly 58 is screwed into
20 the appendage 16 or 17, the appendage may be pulled into the inverted position by applying pulling forces to the catheter body 52.

Since the distal helical member 58 is preferably hollow and attached to a tube with an
25 internal lumen passing from the distal tip to the handle assembly, radiopaque contrast material 60 may be injected to detect the location of the distal tip of catheter 50 using, for example, fluoroscopy. This is important so as to ensure that the distal
30 end of the helical coil needle 58 is in the pericardial space and has not perforated the pericardium 53 as shown in FIGURE 11. In addition, the helical coil assembly and/or the distal catheter tip may be radiopaque.

35 Alternatively, an echoluscent material

may be injected to locate the distal tip using transthoracic, transesophageal, and/or intracardiac echocardiography. Also, transponders may be attached to the helical coil assembly for locating thereof by echocardiography.

5

The hollow lumen 55 in the distal helical member 58 can also be used for introduction of an adhesive or bonding material therethrough as will be further set forth hereinafter.

10

Referring to FIGURES 12-15, there is seen an alternative type of grasping catheter 70 provided on a catheter body 52. The catheter tip 74 includes a plurality of grasping prongs 72 which are movable from an expanded position to a retracted position as seen in FIGURES 13-14 for grasping the wall of the atrial appendage 16 or 17, so that pulling forces can be applied for inversion thereof. Preferably, the pronged tips are enclosed in a tubular tip 74 which facilitates introduction of the catheter through the vasculature and into a heart chamber and subsequent withdrawal thereof once the procedure is completed. Prongs 72 are preferably mounted in a mounting block 76 in such a fashion that they are biased toward the expanded position shown in FIGURES 12A and 13. This block 76 is connected to a handle assembly through a stylet 62. As the stylet 62 is retracted at the handle, the block 76 is withdrawn into tubular tip 74; the prongs are caused to contact the interior surface of the tip 74 and move toward each other, thus impaling the surface of the appendage 16 or 17 as seen in FIGURE 14. The prongs are provided with sharp distal ends to readily penetrate tissue and with a wide section at the apex of the curvature to contact a larger amount of tissue thus forming a large surface with which to

15

20

25

30

35

pull tissue. The appendage 16/17 is then inverted by pulling the catheter body sufficiently to cause inversion. The prongs can subsequently be released by distal extension of the stylet 62 and the block 76 thereby allowing the prongs to expand again to the position shown in FIGURE 13. After the prongs 72 are withdrawn from the wall of appendage 16 or 17, they can be returned to the compact position shown in FIGURE 15 so the catheter may be withdrawn from the vasculature.

Alternatively, as shown in FIGURE 12B, prongs 73 are provided which in the expanded form extend radially outward. During introduction of this embodiment into the appendage 16/17, the prongs 73 are collapsed into a low profile and once they have passed through the appendage wall 16/17 or inside the myocardium, the stylet 62 and thereby the block 76 is extended, allowing the prongs 73 to expand from the low profile necessary for insertion to a radiating outward profile which provides a surface with which to pull the appendage 16/17.

Yet another form of catheter attachment and pulling mechanism 80 is shown in FIGURES 16A, 16B and 17. In accordance with this embodiment, a radially expandable flexible member 82 is positioned within a hollow needle 66 located inside the interior of the catheter body 52 and distal tip element 83. Member 82 is attached to stylet 62 which extends from the distal tip 83 to the handle assembly. Flexible member 82 may be made from a memory elastic material such nickel titanium or stainless steel 17/7. More than one flexible member 82 may be attached to a stylet 62, if desired, to increase the surface provided for pulling on the appendage 16/17.

Externally operable control means, such as extendable/retractable proximal knobs, are provided for advancing the stylet 62 and hollow needle 66 independently of one another. Preferably, the distal end of the hollow needle 66 is extended through the appendage 16/17 and accesses the pericardial space. As previously described, a contrast material may be injected to confirm the location of the distal tip of hollow needle 66. Then, the stylet 62 is advanced thereby expelling the flexible member 82 and allowing it to expand from the position shown in FIGURE 16A to that shown in FIGURE 16B. The distal tip of the hollow needle 66 is provided with a sharpened point suitable for penetration of the appendage wall 16/17 when the flexible member 82 is in the retracted position. Then, after penetration of the wall 16 or 17, the flexible member 82 expands into its predetermined shape and the catheter is thereby attached to the wall as seen in FIGURE 16B. In this position, a substantial pulling force can be applied to the atrial appendage 16 or 17 to cause inversion of the same.

The hollow needle 66 may be retracted into its retracted or resting position in element 83 to minimize any damage the sharp distal needle tip may cause while pulling the appendage 16/17. In addition, the flexible member 82 may be coiled at its distal end to prevent perforation of the tissue especially that of the pericardium while manipulating the member 82 by means of stylet 62. In an alternative embodiment, the member 82 can have a blunt end instead of a coiled tip. In FIGURES 16 & 17, the member 82 is attached to the stylet 62. An alternative configuration of the flexible member

82 (fully expanded) is shown in FIGURE 17.

A number of additional shapes not shown in the FIGURES can function as member 82. Any flexible self-expanding member or configuration which may be extended into a low profile to fit inside a hollow needle or a catheter body and when extended beyond the distal end of the constraining tube will expand, may be used to provide an attachment point to pull the appendage 16/17 into an inverted position.

To retract the flexible member 82 from the attachment point 42, the sharpened hollow needle 66 is reinserted into the tissue to the proximal surface of the tissue and the flexible member 82 is removed by pulling the stylet 62. Thereafter, the hollow needle 66 and flexible member 82 are positioned in their retracted positions so the catheter may be safely removed from the vasculature. The handle 64 shown in FIGURES 33A and 33B can be used for this purpose. The rod 69 can be removed from the assembly shown in FIGURE 33B and a stylet 62 and flexible member 82 substituted therefor.

Methods & Devices for Affixing the Inverted Appendages

Referring to FIGURES 18, 19A and 19B, there is shown a compound loop assembly 77 carried on the distal end of a catheter 52. Loop assembly 77 may be used as a support structure for pulling therethrough of appendage 16 or 17. As seen in FIGURE 18, assembly 77 is housed in an introducer sheath 74A. An extendable/retractable support block 76A is manipulated by extension and retraction of catheter body 52 relative to sheath 74A. A central opening 75 in support block 76A allows for introduction of a separate attachment catheter, for example, catheter 70 through the central lumen of

catheter 52. One or more supporting splines 78 are attached to block 76A and support another loop 79 which is of a size adapted to encircle the appendage 16/17 when inverted as shown in FIGURE 19B. In the
5 embodiment of FIGURES 19A AND 19B, catheter 70 is introduced separately from catheter 52.

This compound loop assembly 77 provides a support structure to appropriately deform the atrial
10 appendage into a necked pouch to facilitate subsequent attaching methods as described below. Any of the attaching catheters described above may be used in conjunction with the compound loop structure. The compound loop catheter 77 may
15 contain multiple loops to enable pulling of the appendage 16/17 into multiple small inverted sections of tissue instead of one larger inverted section.

An alternative support structure, which may also be used itself to fix inverted appendage tissue
20 in an altered position is shown in FIGURES 20-22. Here there is seen the use of a dual catheter system including a tying catheter 88 which inserts a lasso member 90 around a grasping catheter 70, which is shown for purposes of illustration. In FIGURES 20-
25 22A, the appendage 16 or 17 is shown in the inverted position. Subsequently, the lasso member 90 is elevated around the inverted appendage 16 or 17 and thereafter tied by pulling the free end of the lasso member 90 by means of a stylet 62, which extends
30 proximally into a handle assembly. Lasso member 90 is thus formed into a tightened configuration which holds and assists in moving the inverted appendage 16 or 17 into the position shown in FIGURE 22A.

FIGURE 22B shows one embodiment of a lasso
35 member 91 which has a ratcheting mechanism to

permanently tighten when the member 91 is pulled by the operator. In this case teeth 92 are adapted to slide through a slot 93 in a direction which allows tightening of the lasso, but does not allow loosening thereof. After the lasso member 91 has been tightened to maintain the position of the inverted appendage 16/17, the lasso member 91 is cut, leaving the tightened lasso in place. As seen in FIGURE 22B, the lasso 91 is compressed to fit within an introducer sheath 74 for introduction into the atrium. The lasso 91 is formed in a size sufficient to encircle the inverted atrial appendage. As seen, slot 93 is formed as a constriction between an anchoring member 94 and an opposed finger 98 which engages ratchet projections 92. Finger member 98 as seen in FIGURE 22B allows the ratchet projections to slide in a downward direction, but prevents them from moving upwardly. A cutter 100 is provided to cut the lasso 91 loose from the catheter. Cutter 100 is actuated by pulling in a proximal direction on stylet 62. The back of cutter 100 is contoured to slide over a projection 102 that causes the cutter to engage lasso 91 and force it against a backing member 103 so that the sharpened tip of cutter 100 will sever the lasso 91. After lasso 91 has been severed, the anchor member 94 remains with the lasso and is disconnected from the catheter body 105 by rotation of the catheter body to disconnect a threaded connection as shown. A retaining ring 104 holds the cutter and backing member in place centrally within the catheter body 105.

An alternative embodiment for attaching the appendage 16/17 uses an inverting catheter described above and the tying catheter 88 with a lasso member

90 previously described via a thoracostomy. The probe system is inserted through an opening made in the intercostal space of the rib cage and advanced through the pericardium where it contacts the appendage 16/17. The inverting catheter is attached to the distal end of the appendage 16/17 with techniques previously described and is pulled so as to stretch the appendage structure 16/17 away from the main body of the atrium. Then, the lasso member 90 is wrapped over the stretched appendage 16/17 as far toward the main atrial body as possible. The lasso member 90 or 91 is subsequently tightened using techniques described above to isolate as much of the appendage 16/17 as possible. Subsequently, the appendage 16/17 may be cut and permanently removed by advancing another probe with a cutting surface to cut the neck of the appendage pouch leaving the lasso member 90 or 91 holding the rest of the appendage in place. Additionally, the lasso member 90 or another cauterizing probe may be used to fuse the appendage walls 16/17 together as will be described below for additional support after cutting off the appendage 16/17.

A further modified affixing embodiment is shown in FIGURES 23-24B. In this embodiment, a helical coil catheter 50 as shown in FIGURE 7 is used in conjunction with a lasso applying catheter 88 which applies a lasso member 90 around the inverted appendage 16 or 17. The hollow lumen of the helical distal end 58 of catheter 50 is used to infuse a chemical fixing agent such as a cyanoacrylate 89, which after curing, affixes the inverted appendage 16 or 17 in the position shown in FIGURE 25. While a cyanoacrylate is the preferred adhesive used in conjunction with this embodiment of

the invention, other materials, for example other acrylate based adhesives such as polymethyl methacrylate or other biocompatible materials can be substituted.

5 The catheter infusion lumen may have a Teflon[®] polytetrafluoroethylene (PTFE) or similar inert material surface inside to reduce the extent of adhesive curing in the lumen prior to injecting the adhesive into the desired region. Also, more
10 than one lumen may be contained within the catheter body to connect the helical coil hollow distal section to the injection site at the handle. As seen in FIGURE 25, separate lumens 48 and 49 may be used to inject adhesive 89 and a contrast material
15 to enable the injection of either contrast material or adhesive into the desired region without needing to displace the dead volume of another material from the lumen. Thus, one is able to quickly inject contrast at any point during the procedure to ensure
20 the catheter has not moved while injecting the chemical adhesive. Also, an additional lumen may be required to inject simultaneously a catalyst and an adhesive to enhance the curing of the adhesive in the desired region. In FIGURE 25 lumens 48 and 49
25 both discharge into a enlarged area 47 in distal tip member 54A, which in the case of two part curable materials can be used to provide for mixing of the two components. The desired ratio of catalyst to adhesive for proper curing may be achieved by
30 designing the ratio of the respective lumen diameters to match this ratio and controlling the respective infusion stylets to move simultaneously.

The infusion lumens are preferably formed by extruding a PTFE tube and braiding a layer
35 thereover of metal or polymeric plastic material.

Thereafter and outer layer, preferably of a polyamide or polyester polymer is applied by dipping or extrusion.

5 After the adhesive material has solidified, the lasso member 90 may be expanded free from the appendage walls 16/17 preferably by releasing backward pressure on the retracting stylet 62 thus allowing the lasso member to loosen. Alternatively, an extending handle assembly may be actuated to open
10 the lasso member 90 thereby loosening it. For this application, lasso member 90 should not have a latching mechanism, as shown in a prior embodiment, 91, so it may be readily released upon demand. After loosening the lasso member 90, the catheters
15 may be removed from the vasculature.

Referring to FIGURE 26, a releasable lasso member 142 may be manufactured from electrical conductors such as platinum/iridium, gold, stainless steel, or other metallic coils or rings and may be
20 attached through electrically conductive wires 141 traversing the catheter lumen 140 to a radiofrequency generator, such as the EPT-1000, which transmits current at 500 kHz to the lasso member 142 to resistively heat the appendage walls 16/17. This electrically isolates the appendage
25 16/17 to ensure no arrhythmogenic fibrillation, tachycardia, and/or flutter originates from the trabeculated appendage. In addition, heating the appendage walls can thermally fuse the adjacent appendage walls together producing a bond to hold
30 the appendage 16/17 in the inverted position. Alternatively, heating changes the structure of the tissue through desiccation to change the shape of the appendage 16/17 even if a thermal bond of
35 adjacent walls is not achieved because the required

bonding temperatures are not reached. These changes in structure will help maintain the appendage 16/17 in the altered position. Of course, temperature sensors placed in the lasso member 142 may be used to regulate the heating to controllably ablate the appendage walls and/or thermally fuse adjacent walls together. Devices usable for this purpose are shown in greater in commonly owned copending application Serial Number 08/439,824 filed May 12, 1995, the disclosure of which is incorporated by reference herein.

The composite loop structure 78 previously described may also be formed of an electrically conductive material and used to thermally heat and/or fuse the appendage 16/17 as described above.

Another method for affixing the appendage walls in an inverted or alternative position involves to insertion of an attachment member into or over the appendage 16/17. This technique may be implemented when attaching the appendage in an inverted position or pulling adjacent appendage walls together to produce a sack with the appendage pouch separated from the atrium.

FIGURE 27A illustrates a mesh 95 constructed from a memory elastic material with temperature responsive transitional properties and/or superelastic properties, for example nickel titanium. Alternatively, a plastic material with elastic properties or stainless steel 17/7 may be utilized. The mesh 95 may be expanded over the inverted appendage with the catheter 130 shown in FIGURES 27B and 27C. Alternatively, the mesh 95 may be introduced into the pericardial space with a catheter of the type shown in FIGURES 29 and 30. In this case, a sharpened hollow needle 66 is

introduced through the appendage wall 16/17 into the pericardial space. Then, a separately actuated stylet 62 is manually or automatically extended to insert the mesh attachment member 95 through the end
5 of the hollow needle where it expands to its resting shape at body temperature to maintain the appendage 16/17 in said shape.

Referring now to FIGURES 27A-C more particularly, there is seen an attaching catheter 50
10 which is sized to fit within an inner lumen 128 located in mesh introducing catheter. The attaching catheter 50 and the mesh introducing catheter 130 may be simultaneously introduced into the atrium. Alternatively, the attaching catheter 50 can be
15 introduced into the atrium and attached to an appendage wall 16-17. The introducer catheter 130 can then be guided over the appendage attaching catheter 50. The mesh 95 is seen in its resting configuration in FIGURE 27B.

20 Mesh 95 is supported within an introducer sheath 132 and on a base plate or cylinder 134 which is provided with an annular opening 136 to allow catheter 50 to fit therethrough. Preferably, a retaining ring 138 is provided to hold the wires 140
25 which may be, for example, in the form of a suture or wire.

In use, catheter 130 is introduced over catheter 50 in the appendage 16/17. The introducer sheath 132 and the retaining ring 138 and thus the
30 pull wires 140 are retracted proximally forcing the distal end of the mesh to expand radially. The expanding mesh 95 is then advanced over the inverted appendage 16/17. Subsequently, the wires 140 are released from retaining ring 138 allowing the mesh
35 95 to close over the atrial appendage 16/17. The

wires 140 are then retracted into sheath 132 and the assembly is then removed from the vasculature.

Two alternative handle designs for the various catheters referred to above are shown in
5 FIGURES 33A and 33B. In FIGURE 33A, a fixed introduction tube assembly 150 has an internal lumen 152 in which expandable anchors and/or a stylet may be inserted. In FIGURE 33B, the introduction tube assembly 170 is axially moveable. In one
10 embodiment, separate attaching and grasping catheters are used as a system. In an alternative embodiment, a single catheter of the type shown in FIGURES 29 and 30 with an integrated grasping mechanism, such as a helical coil, may be used.

15 In FIGURE 33A there is seen a typical catheter steering and manipulating mechanism. Catheter body 52 having a distal tip portion 54 extends distally from a handle portion 64 which contains a steering handle 63 to which steering
20 wires 61 are attached to effect bending of steering mechanism 57 remotely from handle 63. Conductive wires 65 may be included in the event that it is desired that, for example, a mapping electrode be positioned on distal tip 54 to detect electrical
25 activity within the heart.

The embodiment of FIGURE 33A includes an expandable anchor introduction and/or push rod port 67 and a separate infusion port 68 through which liquids can be introduced when needed in accordance
30 with the above-described procedures. A porous membrane or slotted hollow tube 71 can be provided to allow flow of liquids from port 68 into the lumen of introducer port 67. In the embodiment shown in FIGURE 33B, a push rod 69 is included for the
35 purpose of advancing expandable anchors or other

components introduced into the atrium in accordance with the invention. Advancing of rod 69 distally will advance the materials contained in the introduction lumen 67 in a distal direction into the atrium. In this latter embodiment the entire infusion assembly 150 is axially movable so that the same can be advanced manually in order to effect tissue penetration when required in accordance with the foregoing descriptions.

FIGURE 28 shows a helical winding used as an attachment member 96 for holding the appendage 16/17 in place. The catheter shown in FIGURES 29 and 30, and the handle assemblies shown in FIGURE 33A or 33B may be used to introduce the helical winding 96. The helical winding 96 is preferably made from a memory elastic material as described above. The helical winding 96 is introduced in an extended shape which may easily be pushed into the appendage walls 16/17 and after the helical winding 96 extends beyond the hollow needle 66 via extension of the stylet 62, the helical winding 96 expands into its resting shape holding the appendage 16/17. Alternatively, the helical winding 96 may be made from a stiffer material such as stainless steel 17/7 and screwed into the tissue.

FIGURE 29 is a sectional view of a catheter which may insert the metallic mesh 95, the helical winding of FIGURE 28, or other material with an elastic memory into or through the inverted appendage to maintain the appendage in the inverted position. FIGURE 29 shows a catheter 110 having a hollow needle distal tip portion 66 that contains an attaching expandable anchor 116. The hollow needle is reciprocally fitted in a distal tip member 114 which has a central opening sized to allow

reciprocation therein of the hollow needle 66. Distal tip 114 is secured by conventional means to a catheter body 112 within which is provided a steering mechanism 57 as described above. Also, fitted reciprocally within hollow needle 66 is a pushing stylet 118 which is utilized to expel expandable anchor 116 after the proper location has been reached through use of the sharp and hollow needle 66. After the tip has been placed in the desired position, the expandable anchor is expelled from the needle by extending stylet 118 and subsequently retracting the hollow needle 66 and the pushing stylet 118 within the rounded distal tip member 114.

Methods & Devices for Affixing Adjacent Appendage Walls

FIGURES 31A-31C show a mechanism which creates a purse-string-like constriction around the interior surface of an appendage 16 or 17 (or other body cavity). This arrangement enables pulling of adjacent walls together, thus forming a tightened sack in which the pouch of the appendage is separated from the remainder of the atrium. Expandable anchors 116 of the type shown in FIGURES 31C or expandable anchors 120 shown in FIGURE 32 may be introduced through the appendage wall 16/17 by means of a catheter similar to the one shown in FIGURE 29. In such case multiple expandable anchors 116 or 120 are placed within the hollow needle 66 and are interconnected with a suture, wire, or similar material 126. The suture 126 may be fed through a loop 117 in the expandable anchor 116 to permit remote tightening of the appendage walls after all expandable anchors 116 have been placed or may be secured to each of the expandable anchors

116 to tighten the walls 16/17 as the expandable anchors are being placed. Ultimately, the appendage walls 16/17 will be pulled together by the suture material 126 in the form shown in FIGURE 31B. To
5 separate the pouch from the atrium, a filler material such as silicone or collagen may be inserted into the appendage pouch to fill the pouch and minimize or eliminate blood flow into or out of the pouch. Also, a memory elastic mesh 95 may be
10 inserted into the pouch or over the sack entrance for additional support and to prevent thrombus movement from the pouch into the atrium. Also, in this embodiment, the blood inside the pouch will clot, forming a naturally occurring support
15 structure for the separated appendage 16/17.

When the form of expandable anchors 120 of FIGURES 32A and 32B are used, suture material 126 may be continuously fed through a central lumen 124 of pushing stylet 124 as shown.

20 Referring to FIGURES 34 and 35, there is seen a procedure for reducing the effective volume of an appendage 16 or 17 by means of a thoracostomy. In this case, the pericardium is penetrated by means of an incision passing through the rib cage. The
25 incision is entered by a grasping catheter, for example catheter 70 as already described hereinabove. Thereafter, a lasso 90 or 91 can be utilized to tie off the neck of the appendage 16 or 17 as seen in FIGURE 34 utilizing a catheter 170
30 shown in FIGURE 35. The appendage can also be fixed in a repositioned location with reduced effective volume by sutures, staples, memory wire, biocompatible adhesives, or by tissue ablation as described above.

35 As seen in FIGURE 35, catheter 170 includes

a flexible catheter body 172 having a distal tip portion 174. A lumen or tubular guide 176 is provided for allowing the lasso 90 to be freely axially movable so that the lasso 90 can be expanded or contracted. Also as seen in FIGURE 35, the lasso 90 may have an enlarged end 8 for the purpose of anchoring the same in catheter distal tip 174 as shown. Utilizing this arrangement, the appendage 16 or 17 can be permanently fixed in the altered position utilizing staples, sutures, chemical bonding agents or by means of ablation. Alternatively, also a locking or ratcheting loop 91 of the type described above can be permanently put in place to tie off the neck of the appendage 16 or 17.

It should be appreciated that the repositioning and affixing methods and devices described above may apply to aneurysms, or any other body cavities that naturally or pathologically exist.

What is claimed is:

1. A probe device for manipulating an interior body tissue surface comprising, an elongated catheter body, a distal end assembly on said catheter body comprising means for attachment thereof to tissue for application of a pulling force thereto, and external control means operatively connected to said end assembly for selectively effecting attachment of said means to said tissue and for release thereof.
2. A device according to claim 1 wherein said means for attachment comprises a helical coil for impaling said tissue.
3. A device according to claim 1 wherein said means for attachment comprises movable prongs for grasping said tissue.
4. A device according to claim 1 wherein said means for attachment comprises a member for penetration of said tissue and means expandable after penetration of said tissue for securing of said assembly to said tissue.
5. A device according to claim 1 wherein said tissue comprises an atrial appendage and application of said pulling force is effective to cause inversion of said appendage.
6. A probe device for manipulating an interior tissue surface thereof comprising, an elongated catheter body, a distal end assembly on said catheter body comprising means for repositioning said tissue surface; means for affixing said tissue surface in said position, and external control means operatively

10 connected to said end assembly for selectively
effecting said repositioning and affixing thereof.

7. A device according to claim 6 wherein
said means for attachment comprises a hollow helical
coil for impaling said tissue, movable prongs for
grasping said tissue, or a member for penetration of
5 said tissue with means expandable after penetration
of said tissue for securing of said assembly to said
tissue.

8. A method for manipulating an interior
body tissue surface comprising,

providing a probe device which includes an
elongated catheter body, a distal end assembly on
5 said catheter body having means for attachment
thereof to body tissue,

introducing said device percutaneously into
an in vivo body, manipulating said device by
external control means operatively connected to said
10 end assembly into contact with said tissue surface,
effecting attachment of said means to said
tissue,

applying a pulling force to said tissue to
cause repositioning thereof,

15 fixing said tissue in the resultant new
position, and,

releasing said means from said tissue and
withdrawing said probe device from said body.

9. A method according to claim 8 wherein
said means for attachment comprises a helical coil
for impaling said tissue and said coil is rotated in
a first rotational direction to impale said tissue,
5 and said coil is removed from said tissue by
rotation thereof in a second rotational direction
opposite to said first rotational direction.

10. A method according to claim 8 wherein

said means for attachment comprises movable prongs for grasping said tissue, and wherein said prongs are moved distally and laterally in a first direction to impale said tissue and said prongs are removed from said tissue by moving them laterally in a second direction opposite to said first direction.

5 11. A method according to claim 8 including the steps of penetrating said tissue with said means and expanding said means after penetration of said tissue to secure of said assembly to said tissue.

5 12. A method for inverting an atrial appendage comprising,

providing a probe device which includes an elongated catheter body, a distal end assembly on said catheter body having means for attachment thereof to body tissue,

5 introducing said device percutaneously into an atrial appendage in an vivo body,

10 manipulating said device by external control means operatively connected to said end assembly into contact with a tissue surface of said appendage,

effecting attachment of said means to said tissue,

15 applying a pulling force to said tissue to cause repositioning thereof,

fixing said tissue in the resultant new position, and,

20 releasing said means from said tissue and withdrawing said probe device from said body.

13. A method according to claim 12 wherein said appendage is inverted.

14. A method according to claim 12 wherein said appendage is fixed in said inverted position.

15. A method according to claim 13 wherein the inversion reduces the effective volume to the atrium, thereby reducing clot formation without the need for a thoracotomy.

16. A method according to claim 14 wherein said appendage is fixed by introducing an attachment member through opposite walls of the inverted appendage and fixing said member in the tissue of each of said walls.

17. A securing means for fixing the walls of an atrial appendage together comprising a helically-shaped metallic member that engages at least two surfaces of said atrium thereby securing them together.

18. A member for stabilizing an atrial appendage comprising a metallic mesh inserted within said appendage to provide an anchor for formation thereon of clots and scar tissue thereby reducing the effective volume of said appendage.

19. A probe device for manipulating an interior tissue surface thereof comprising,
a first elongated catheter body,
a distal end assembly on said catheter body comprising means for repositioning said tissue surface;

a second elongated catheter body provided with means for affixing said tissue surface in said position, said second catheter body comprising a second a distal end assembly on said catheter body comprising means for fixing said tissue surface in said repositioned orientation; and

at least one external control means operatively connected to one of said first or second said end assemblies for selectively effecting said repositioning and affixing thereof.

20. A probe according to claim 19 wherein said second end assembly comprises a loosenable lasso.

21. A probe according to claim 20 wherein said lasso is formed of a thermal energy emitting material.

22. A probe according to claim 21 wherein said lasso is operatively connected to a source of RF energy.

23. A method of electrically isolating an atrial appendage comprising introducing a generally circularly shaped electrode supporting probe into an encircling relationship with an atrial appendage, applying ablating energy thereto to electrically isolate said appendage, and, retracting said probe.

24. A catheter for installing expandable anchors into a body comprising a catheter body having a distal tip portion manipulatable by external control, said catheter being adapted to be inserted percutaneously into a body,

said distal tip portion having a central axially extending opening,

an axially movable hollow needle fitted within said central opening and being remotely axially moveable, from a retracted position located within said distal tip portion, to an extended position extending distally therefrom, said hollow needle having a sharp distal tip and a central opening adapted to hold at least one expandable anchor therein,

an axially moveable expelling member fitted within the central lumen of said hollow needle adapted to expel a expandable anchor therefrom by means of an externally actuatable control.

25. A catheter according to claim 24

wherein said distal tip assembly is steerable by means of a steering assembly actuatable by means of a steering control located in a handle connected to the proximal end of said catheter.

5 26. A catheter according to claim 24 wherein the catheter body contains a lumen adapted to feed suture material therethrough in a distal direction for connection to said expandable anchors ejected from said catheter.

5 27. A catheter according to claim 24 wherein said needle is adapted to hold said expandable anchors in a straightened configuration for insertion through tissue, said expandable anchors being returnable to a preselected nonlinear configuration at body temperature.

28. A catheter according to claim 24 wherein said needle and said expandable anchor expelling means are independently actuatable.

5 29. A catheter for installing a wire mesh member into a body comprising a catheter body having a distal tip portion manipulatable by external control, said catheter being adapted to being inserted percutaneously into a body, said distal tip portion having a central axially extending opening, an axially movable annularly-shaped member fitted within said distal tip portion and being remotely axially movable from a retracted position located proximally from said distal tip a distance sufficient to hold an annularly-shaped mesh member, to an extended position extending distally to the end of said catheter,

10 said annular member having a central lumen adapted to receive and allow axial movement therethrough of a second catheter, said second catheter being provided with a means at its distal

15

tip for attaching itself to the surface of a selected body tissue member.

30. A device according to claim 29 further comprising a member on the exterior surface of said catheter, said member being adapted to anchor elongated tying members secured to the end of said distal end of said annular mesh member whereby as
5 said mesh member is ejected by said annular member the distal diameter of said mesh member is enlarged.

31. A device for insertion into body tissue to fix said tissue in a preselected orientation comprising

a woven wire mesh member stressed into a first generally annular shape for insertion into
5 contact with said body tissue, said mesh member having a second preselected geometrical shape different from said first stressed shape, said member being changed in geometric shape to said
10 second preselected shape when in its unstressed condition.

32. A catheter for injecting liquid hardenable materials into a body cavity comprising
an elongated catheter body having a proximal end and a distal end

5 said distal end being provided with a distal end member having a central opening therethrough,

at least two lumens extending axially through said catheter to said distal end portion for
10 injecting liquids therein.

33. A device according to 32 wherein said distal tip portion has a chamber located distally from the distal ends of said lumens for mixing liquids flowing distally through said lumens.

34. A device according to claim 32 wherein

5 a hollow helical member in fluid flow communication with said lumens is provided on the distal tip of said catheter for penetrating a tissue wall within a body.

35. A device according to claim 32 wherein said lumens are provided with a chemically inert surface on the interior thereof.

5 36. A device according to claim 32 wherein a remotely controllable steering member is located in said distal tip portion of said catheter said steering member being connected to a means for effecting remote articulation thereof.

37. A device according to claim 35 wherein said inert surface comprises PTFE.

38. A method fixing an atrial appendage in a position wherein the effective volume thereof is reduced comprising

5 inserting a catheter according to claim 1 into contact with a surface of said appendage,
advancing said hollow needle through the wall of said appendage,
expelling an expandable anchor through a wall of said appendage,
10 using said anchor to manipulate the tissue of said appendage to fix the same in a position wherein said appendage has a reduced effective volume.

39. A method of fixing an atrial appendage in a position of reduced effective volume comprising inserting a mesh member into contact with a surface of said appendage,

5 said woven wire mesh member being stressed into a first generally annular shape for insertion into contact with said appendage, said mesh member having a second preselected geometrical shape

different from said first stressed shape, and,
10 allowing said member to change in geometric
shape to said second preselected shape by returning
it to its unstressed condition.

40. A method affixing an atrial appendage
in a position wherein the effective volume thereof
is reduced comprising

5 inserting a catheter into contact with a
surface of said appendage,

expelling liquid hardenable material into
said appendage, whereby said appendage has a reduced
effective volume.

41. A method according to claim 40 wherein
a liquid is expelled through each of said lumens to
said end portion, said liquids being hardenable
after mixing.

42. A catheter device for inserting a loop
of material into a body which can be tightened by
remote control comprising

a catheter body having an elongated tubular
distal tip portion with a distal end,

a proximal lasso component removably
attached to the distal end of said catheter, said
lasso having a first end integrally formed with said
proximal lasso component and a second end extending
into said catheter through said distal end in a
proximal direction,

said second end of said lasso having a
plurality of ramp shaped projections each of said
projections having a proximal edge with a shallow
slope and a distal edge with a sharp slope,

said first end of said lasso having
integrally formed therewith a projecting finger
adapted to engage said projections on said second
end of said lasso to allow movement of said second

end of said lasso in a proximal direction and to prevent movement thereof in a distal direction whereby said lasso can be formed into a tightened configuration within a body,

said second end of said lasso adapted to be severed at a point proximal from said projection and said lasso being removable from said catheter.

43. A device according to claim 42 further comprising a cutting element remotely actuatable from the proximal end of said catheter.

5 44. A device according to claim 43 wherein said first end of said lasso comprises a thickened portion adapted to act as a cam surface upon axial movement of said cutting element which causes lateral movement of said cutting element, whereby said cutting element is caused to sever said second end of said lasso.

45. A device according to claim 44 wherein said catheter includes a backing member adapted to hold said second end of said lasso while severing force is applied thereto.

5 46. A device according to claim 42 wherein said lasso and said catheter body are connected together by mating threads and can be disconnected from each other by rotation of said catheter body relative to said lasso.

5 47. A catheter according to claim 42 further comprising an introducer sheath concentric with body of said catheter and enveloping the same, said sheath being axially extendable for introduction to said lasso into the body and retractable to facilitate severance of said lasso from said catheter body and removal thereof from the body.

48. A catheter according to claim 47

capable of intravascular placement into a heart chamber, said lasso being adapted to encircle an inverted atrial appendage to fix said appendage in said inverted orientation.

49. A method of fixing an atrial appendage to reduce the effective volume thereof comprising
inverting said appendage
encircling said inverted appendage by
5 introducing a lasso catheter into contact therewith,
reducing the circumference of said lasso to
compress the tissue of said inverted appendage,
cutting said second end of said lasso,
disconnecting said lasso from said
10 catheter, and
removing said catheter from the atrium.

50. A method according to claim 49 wherein said lasso is connected to a means for generating ablating energy and the method comprises the step of applying thermal energy to said appendage.

51. A method according to claim 50 wherein said energy comprises RF energy.



2/17

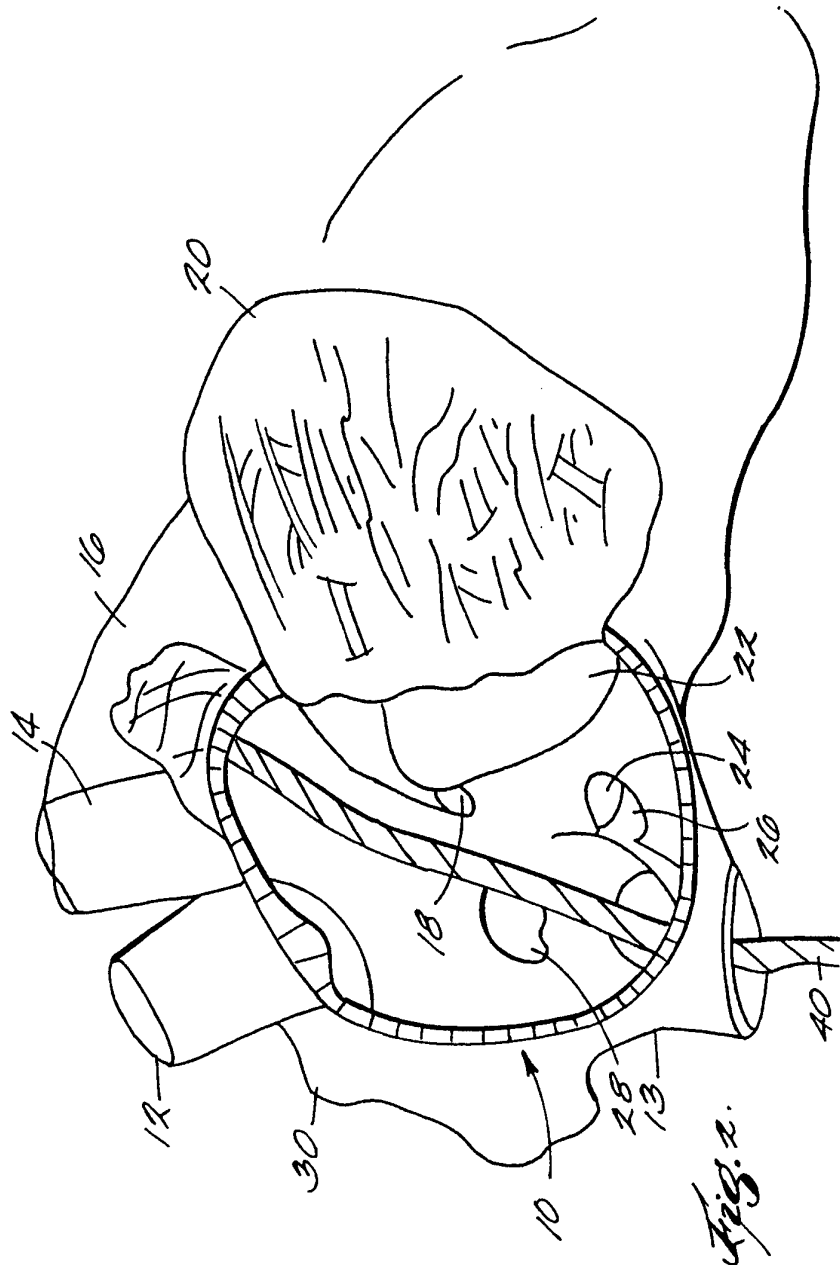

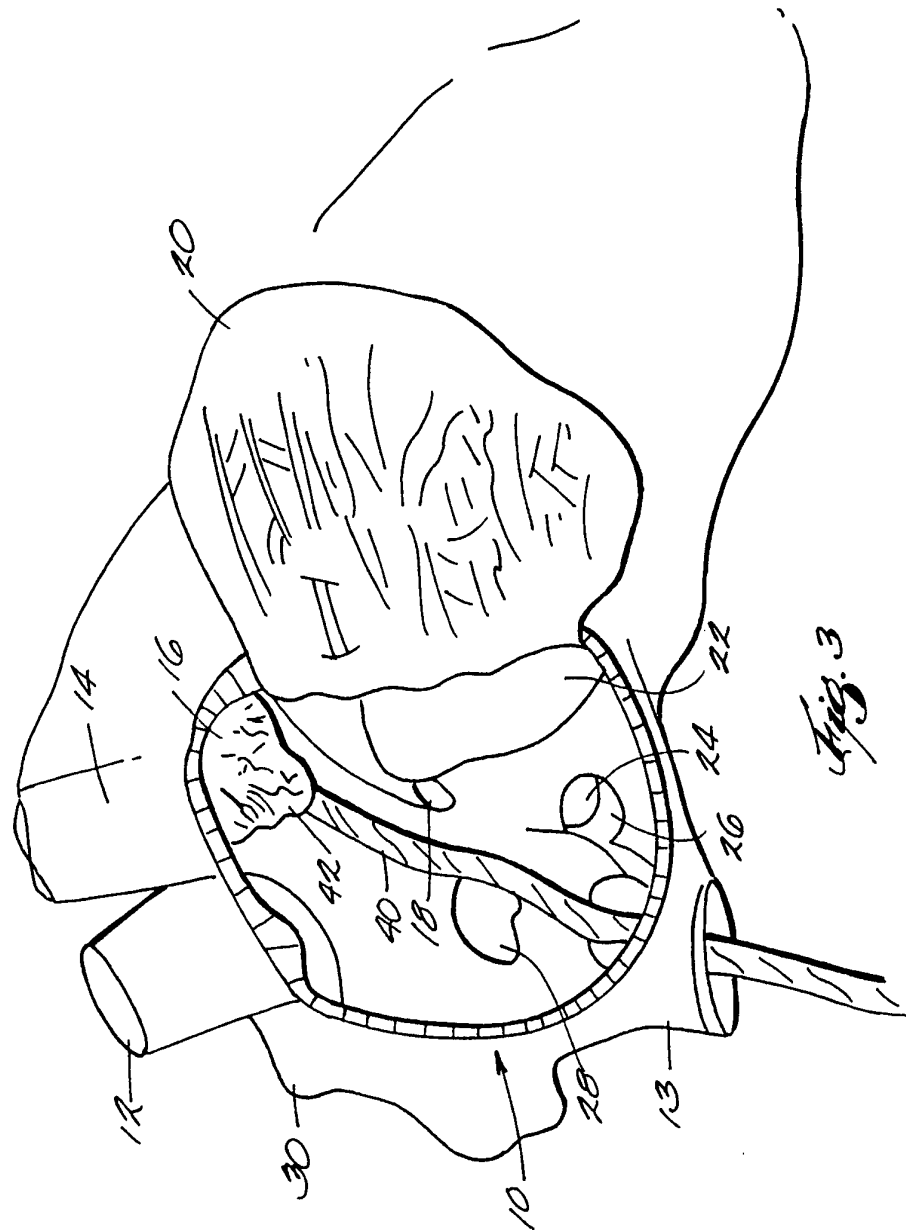

Fig. 3

4/17

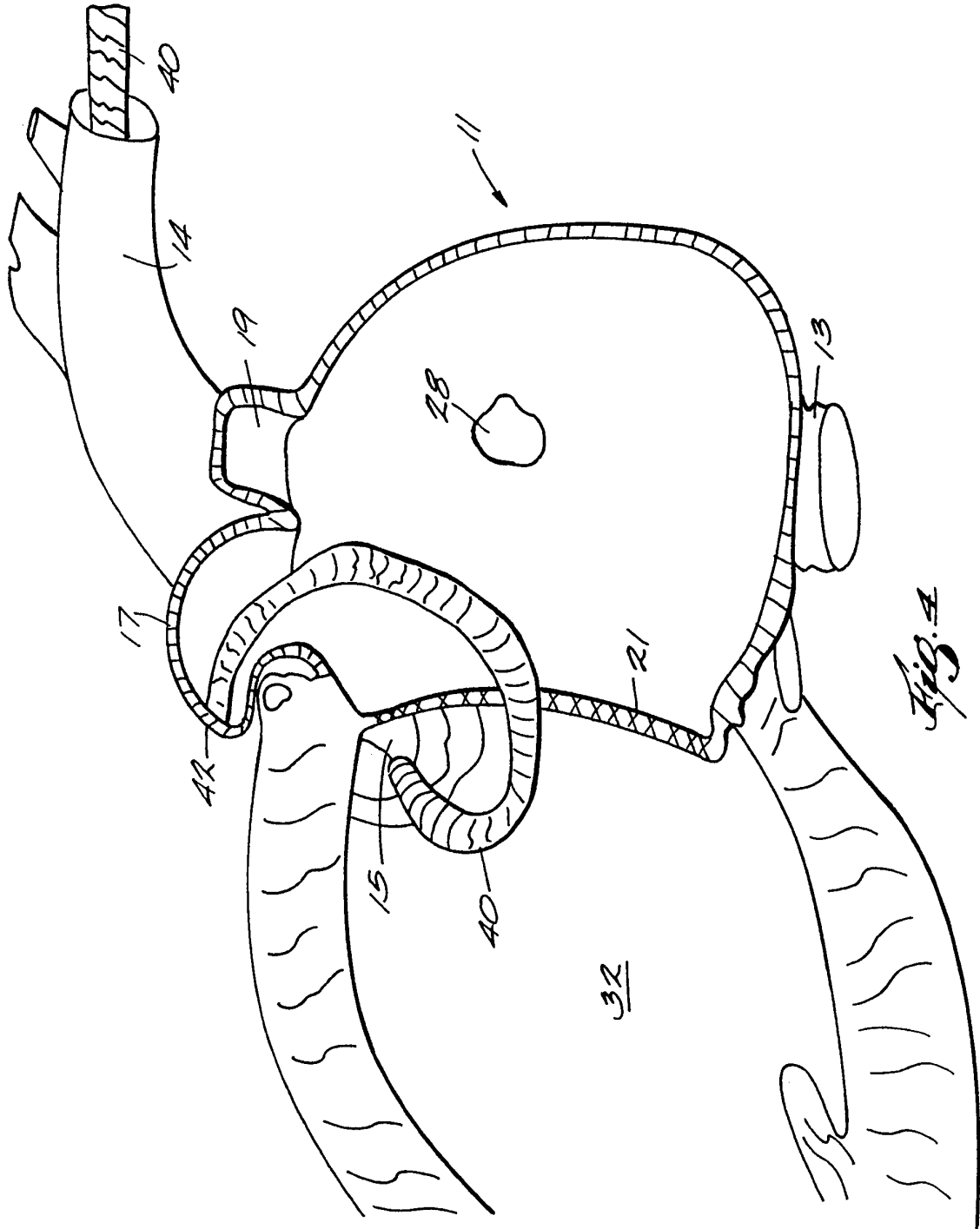
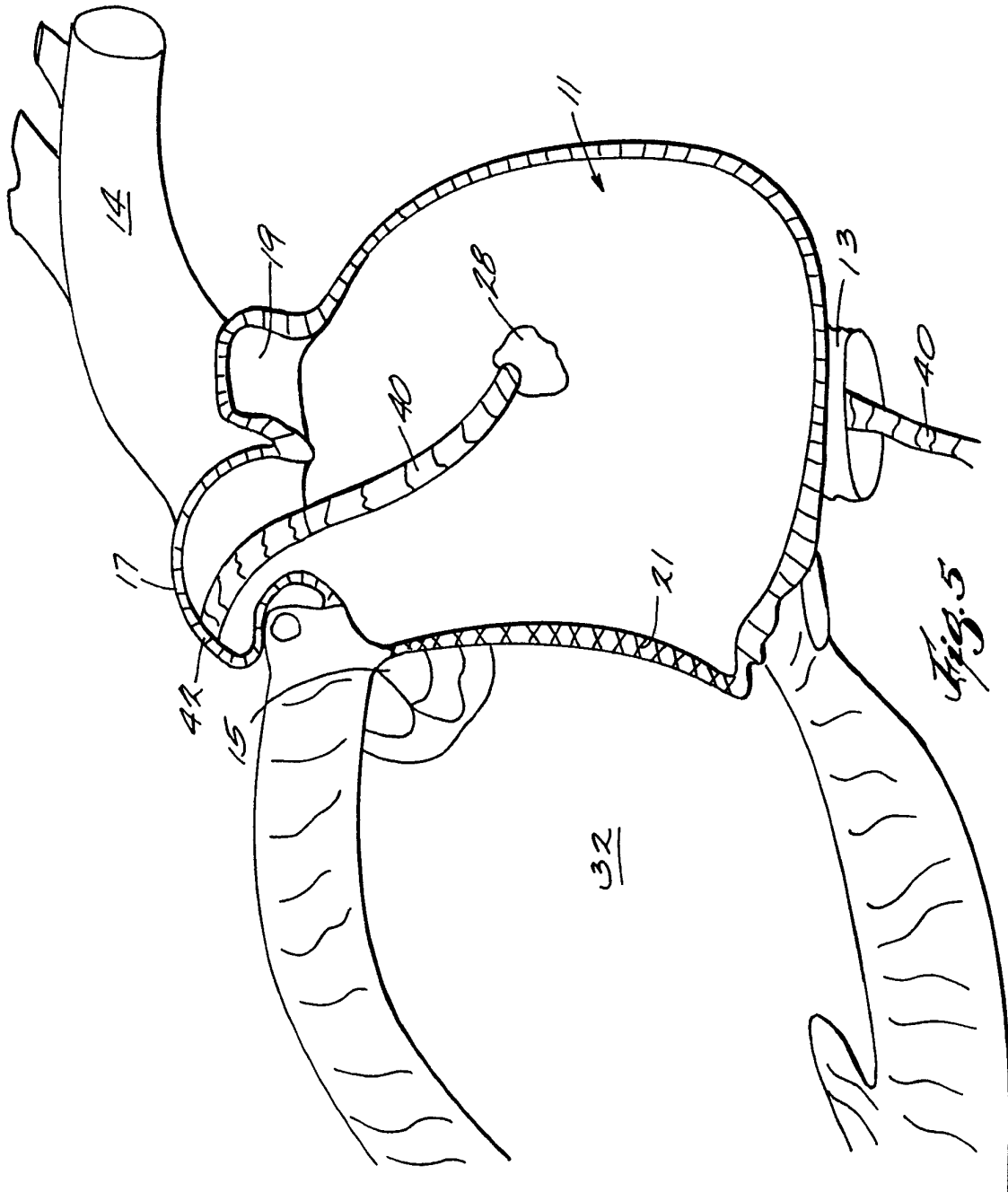
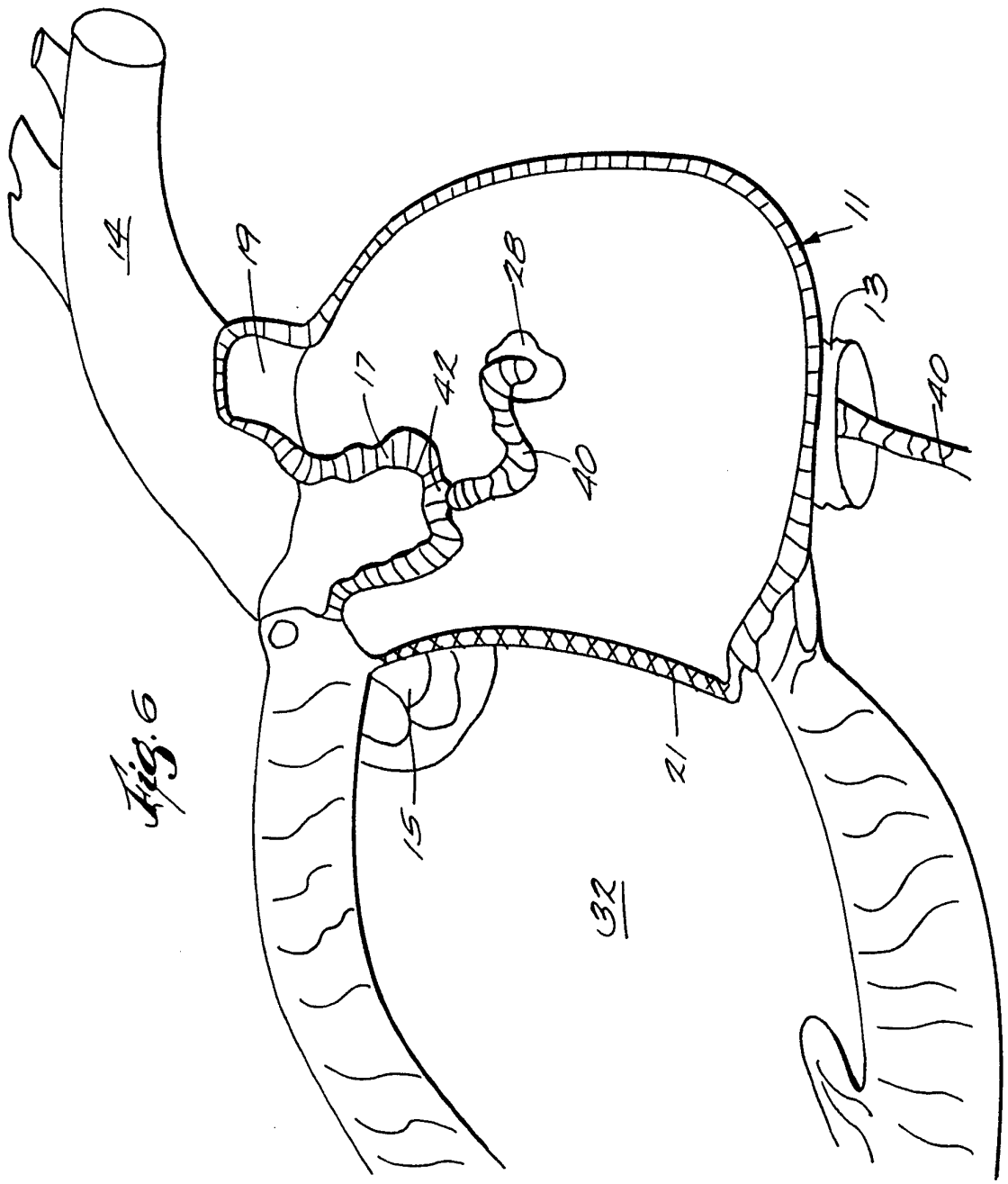

Fig. 4

5/17



6/17



7/17

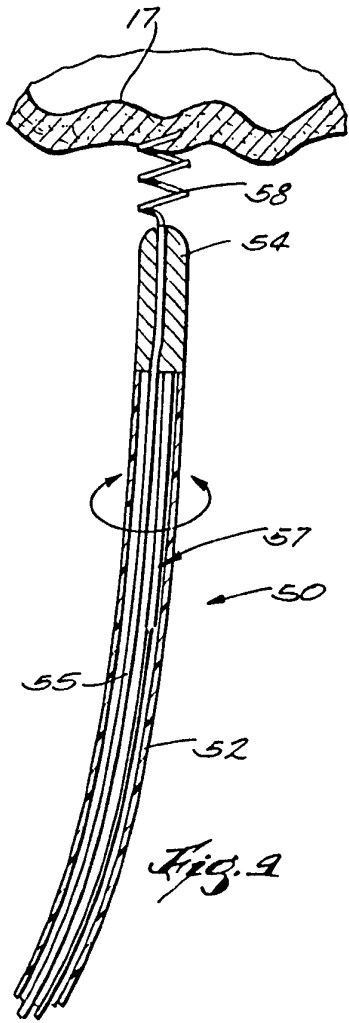

Fig. 9

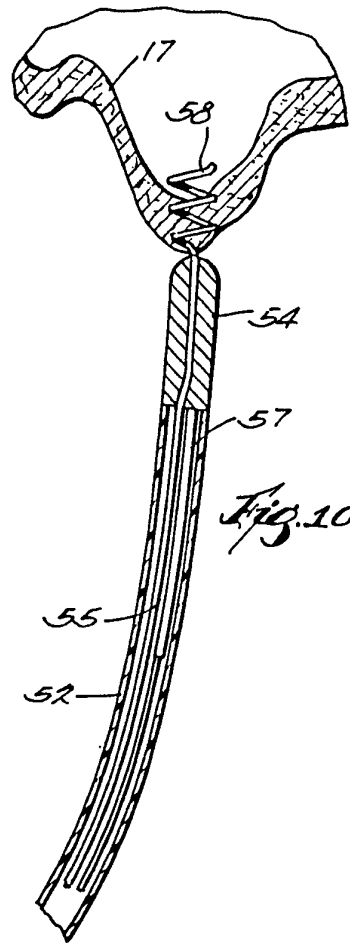

Fig. 10

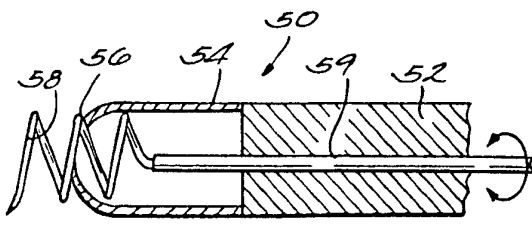

Fig. 8

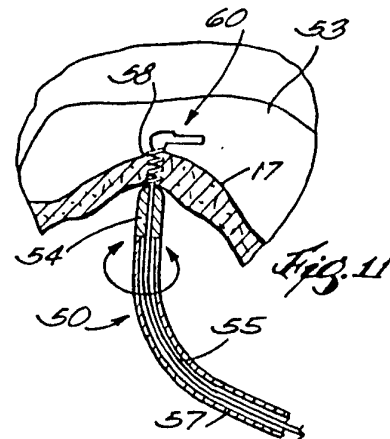

Fig. 11

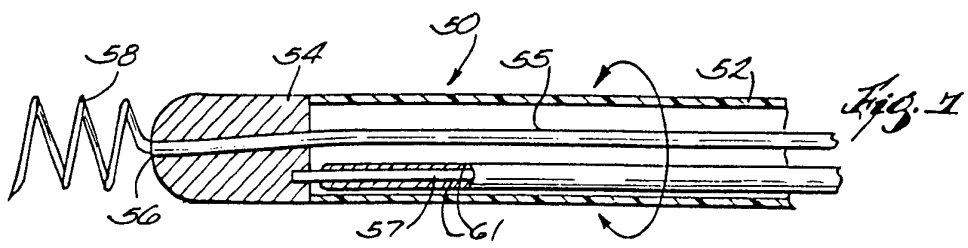

Fig. 1

8/17

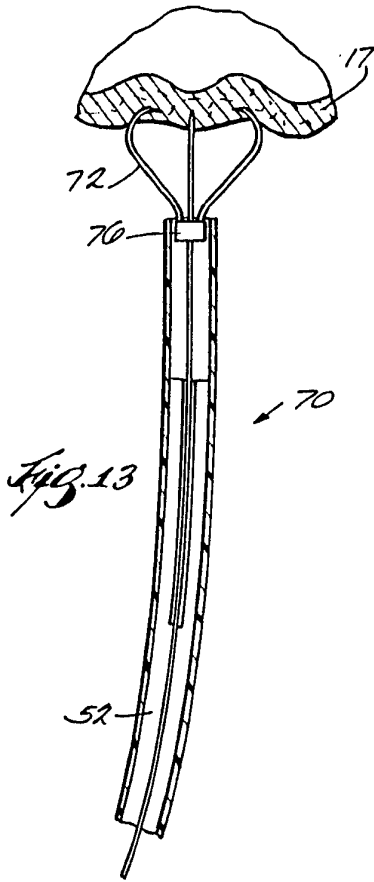

Fig. 13

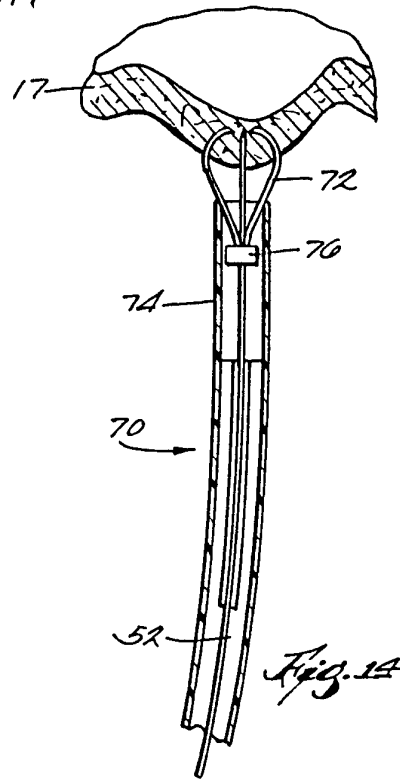

Fig. 14

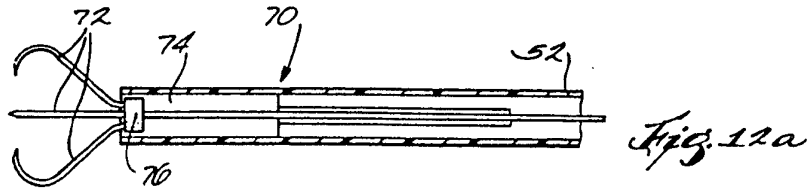

Fig. 12a

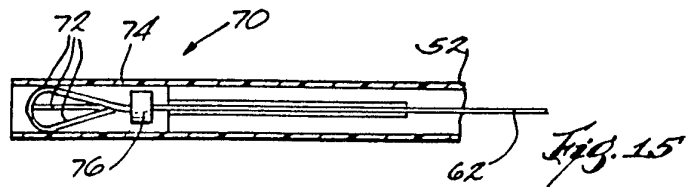

Fig. 15

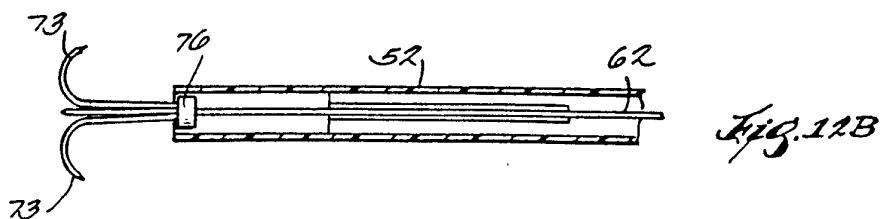
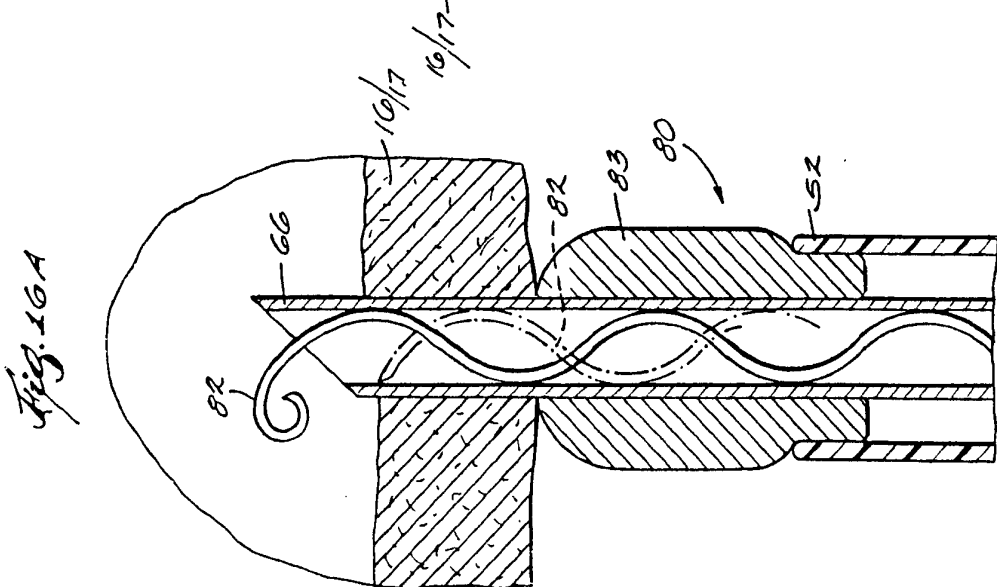
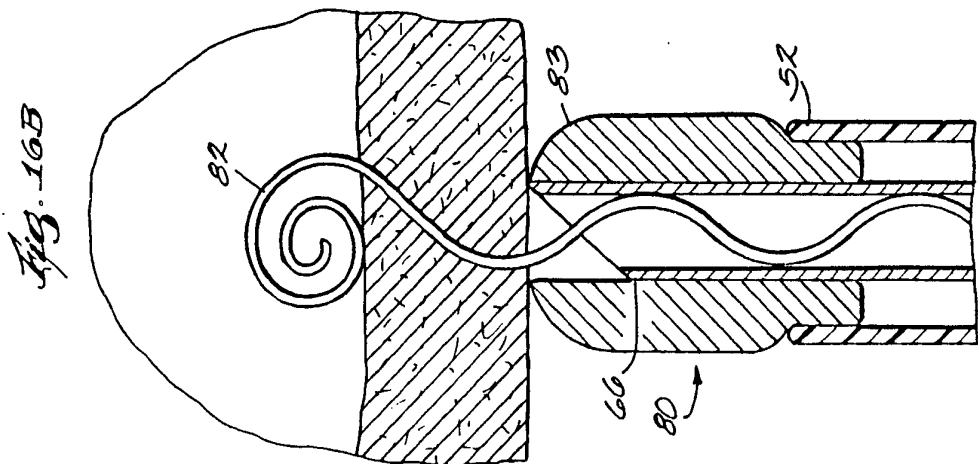
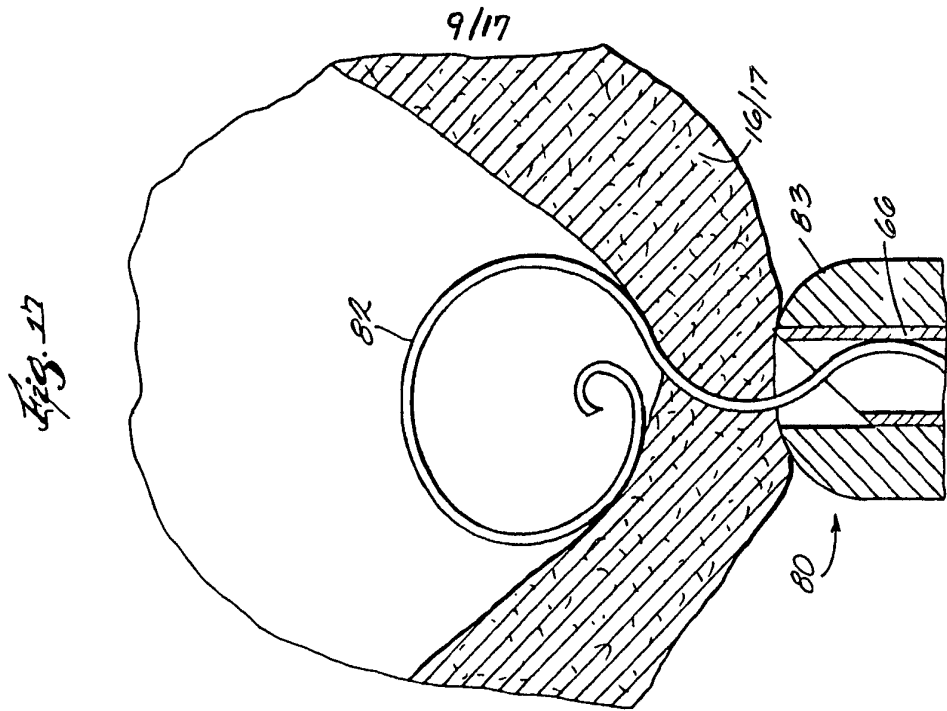

Fig. 12B



10/17

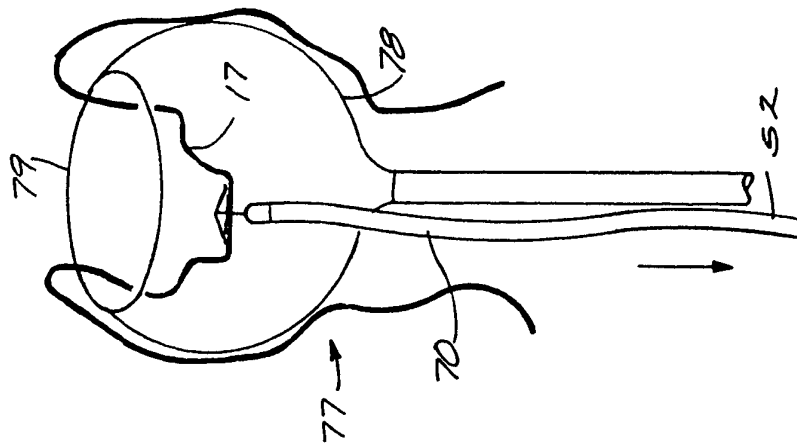

Fig. 19B

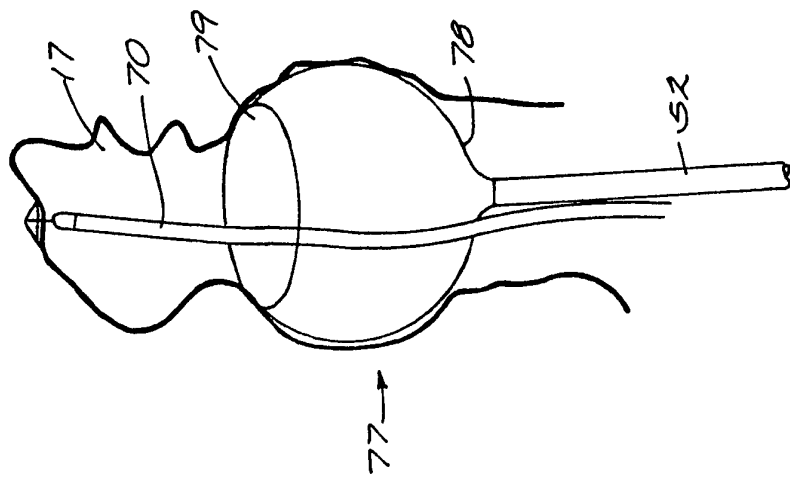

Fig. 19A

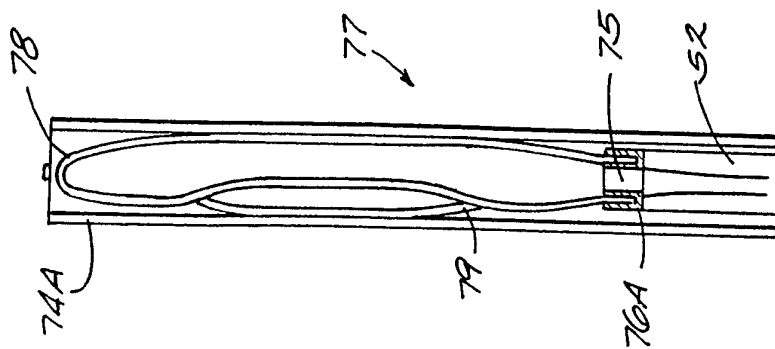
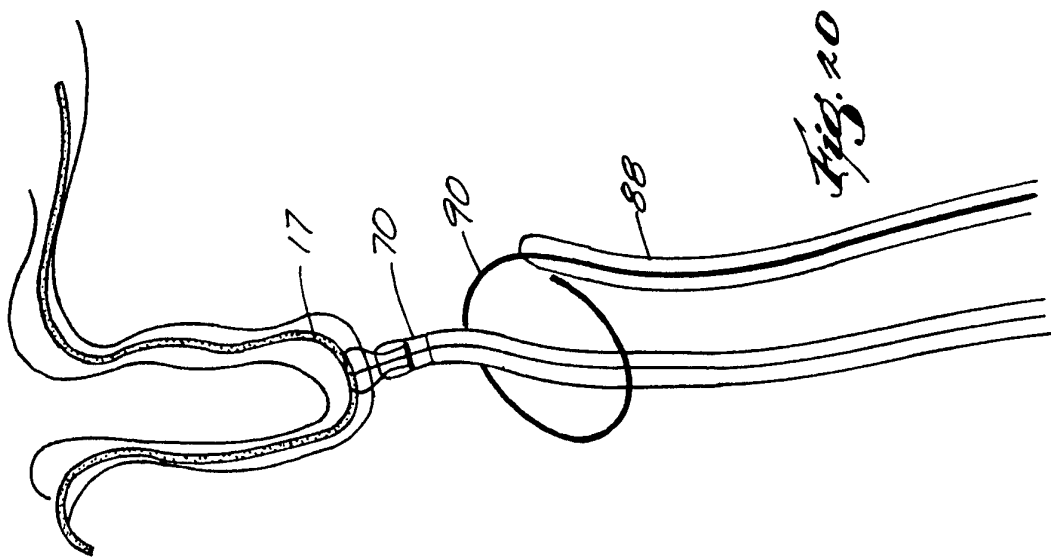
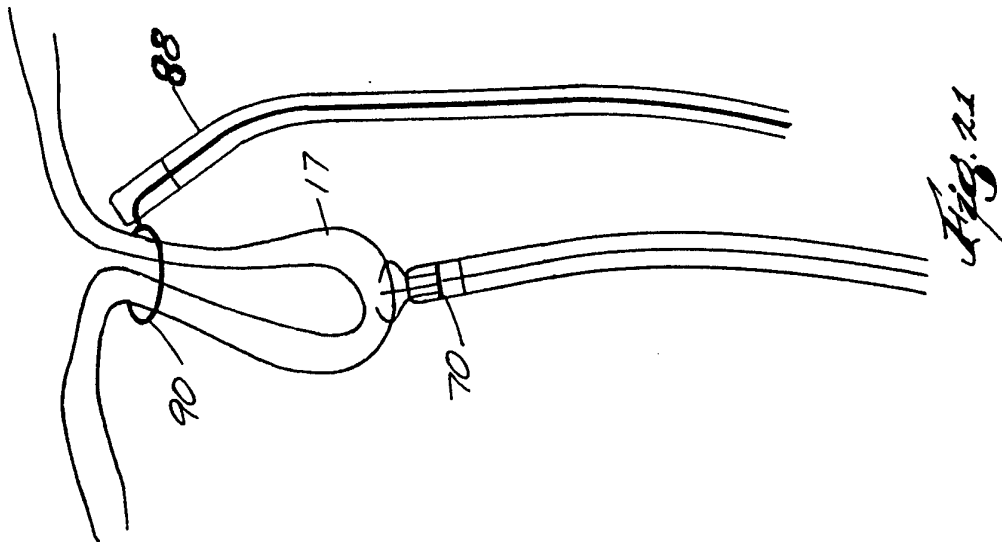
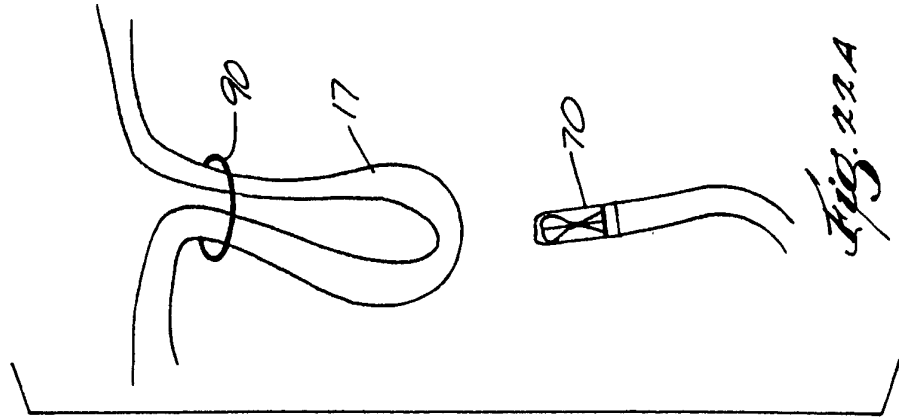
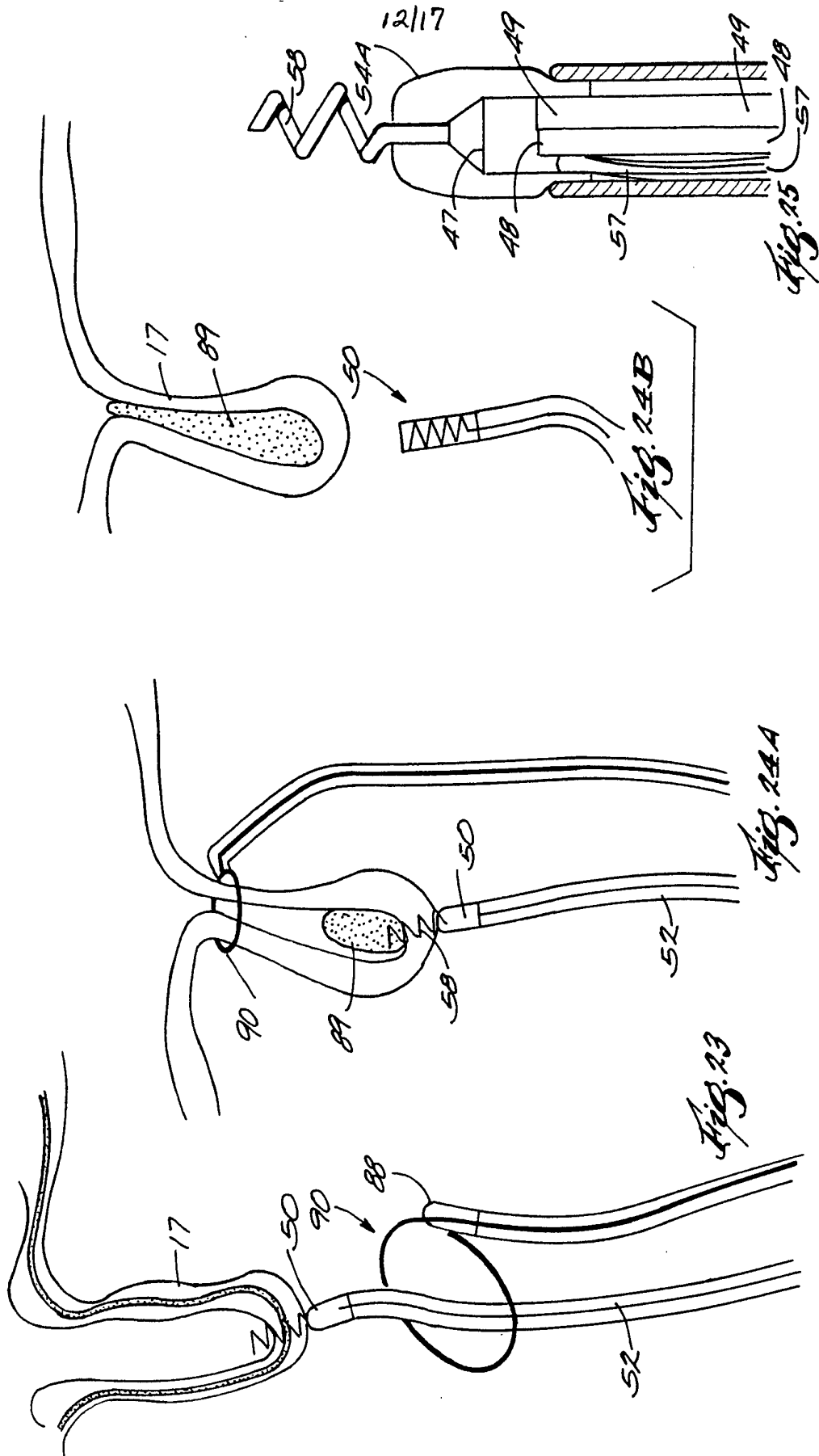

Fig. 18

11/17





13/17

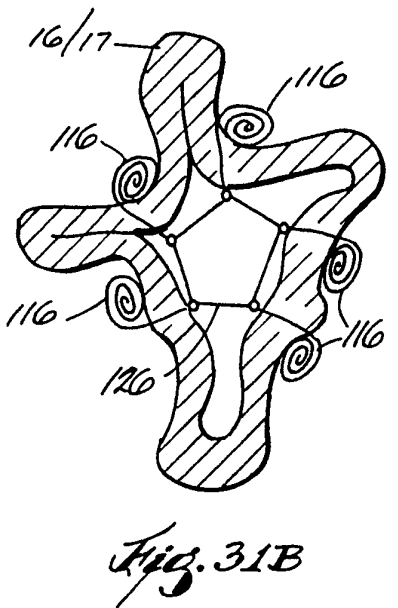
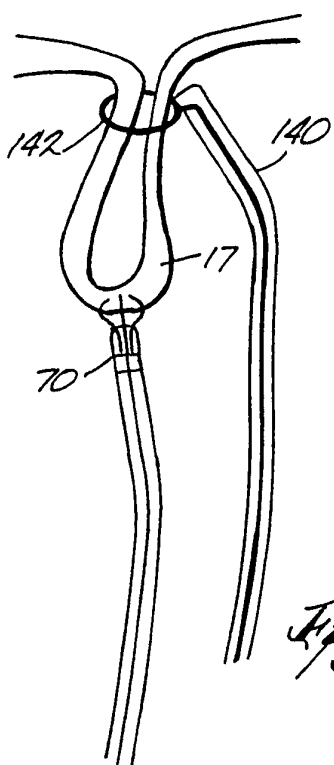
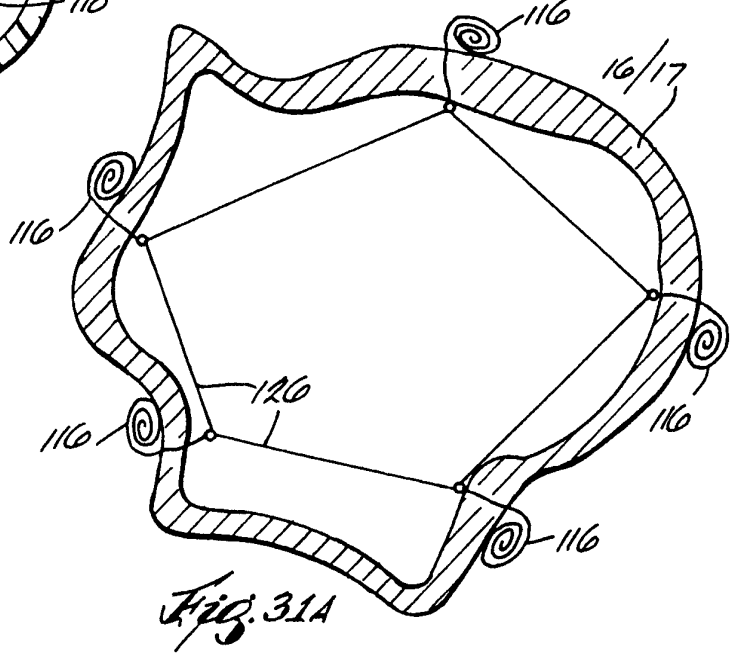
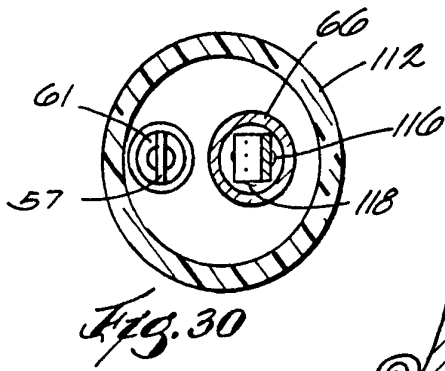

14/17

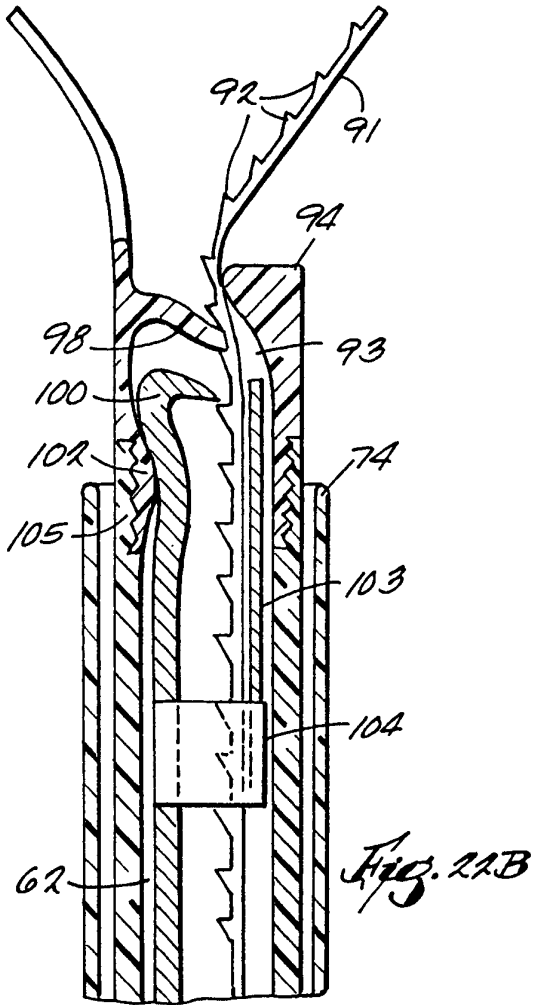

Fig. 21B

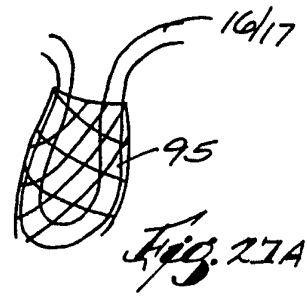

Fig. 27A

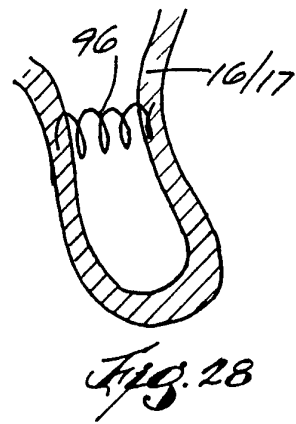

Fig. 28

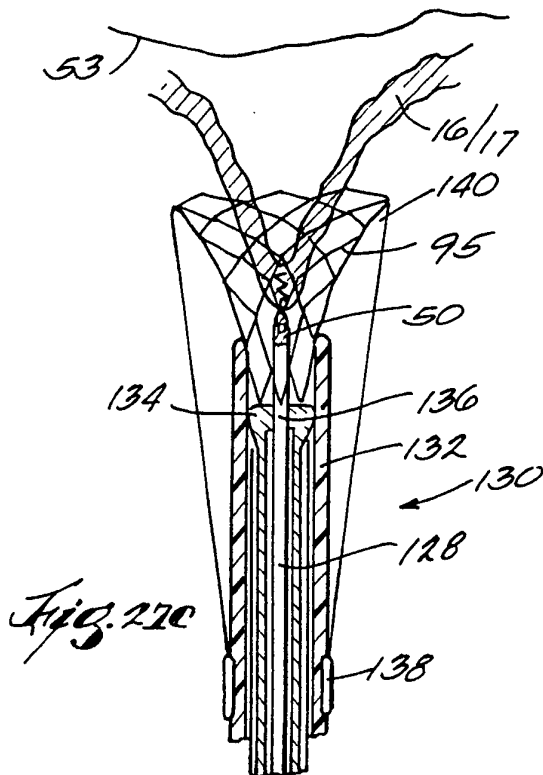

Fig. 21C

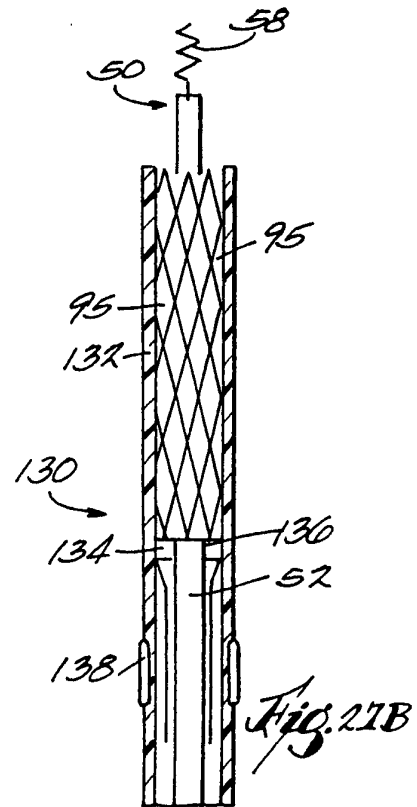

Fig. 21B

15/17

Fig. 29

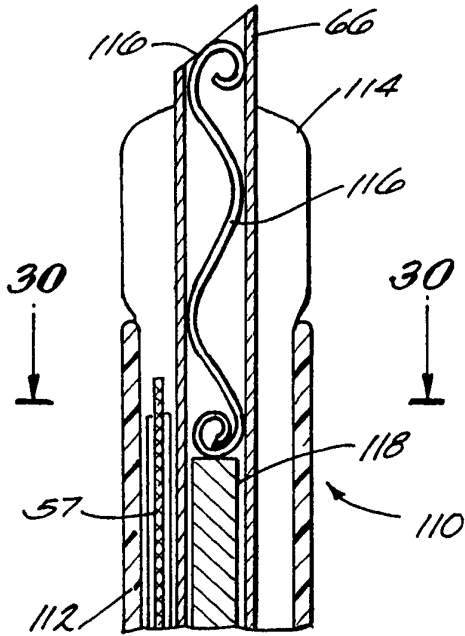

Fig. 32A

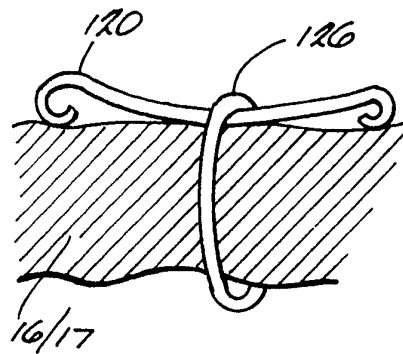
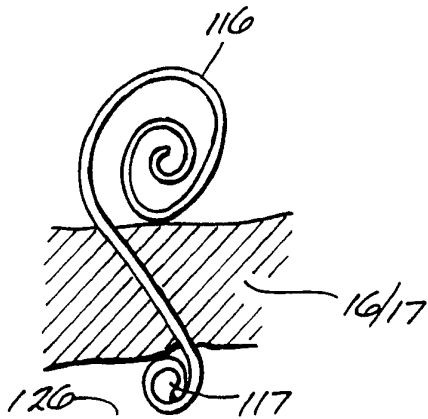
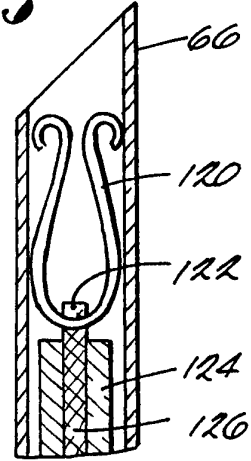
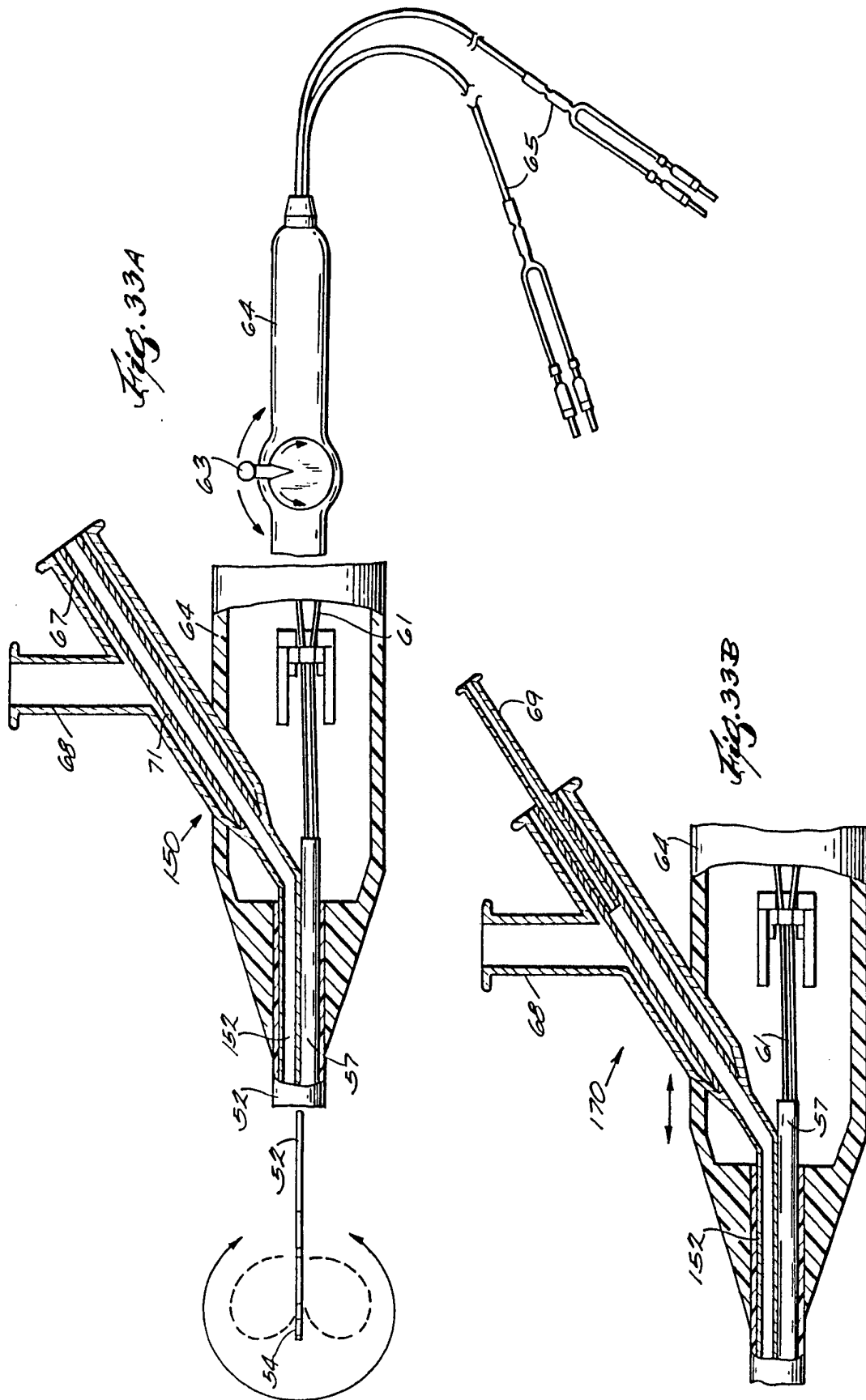

Fig. 31C

Fig. 32B

16/17



17/17

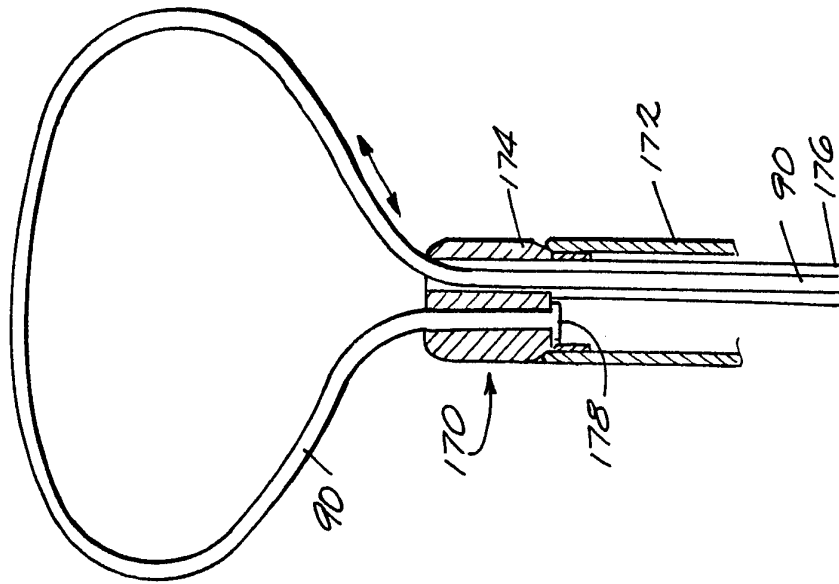

Fig. 35

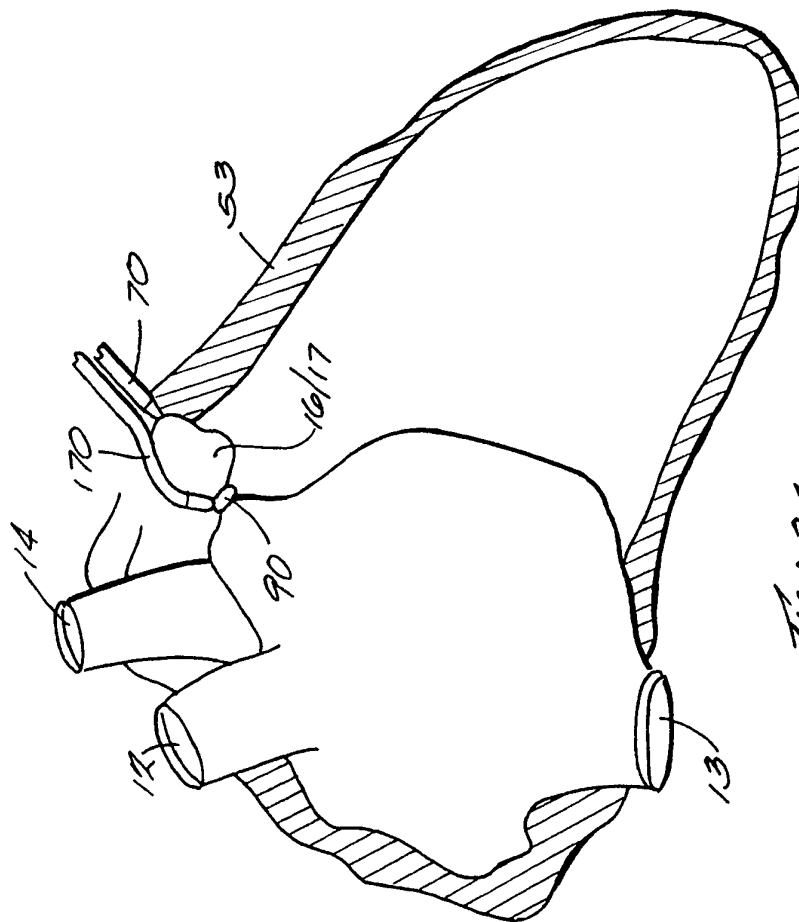

Fig. 34

INTERNATIONAL SEARCH REPORT

International application No.
PCT/US96/09600

A. CLASSIFICATION OF SUBJECT MATTER IPC(6) :A61M 37/00 US CL :604/95 According to International Patent Classification (IPC) or to both national classification and IPC		
B. FIELDS SEARCHED Minimum documentation searched (classification system followed by classification symbols) U.S. : 604/49, 51, 95, 280, 281; 606/194 Documentation searched other than minimum documentation to the extent that such documents are included in the fields searched Electronic data base consulted during the international search (name of data base and, where practicable, search terms used)		
C. DOCUMENTS CONSIDERED TO BE RELEVANT		
Category*	Citation of document, with indication, where appropriate, of the relevant passages	Relevant to claim No.
A	US, A, 5,342,299 (SNOKE ET AL.) 30 August 1994, see entire document.	1-51
A	US, A, 5,318,527 (HYDE ET AL.) 07 June 1994, see entire document.	1-51
A	US, A, 5,318,528 (HEAVEN ET AL.) 07 June 1994, see entire document.	1-51
A	US, A, 5,324,284 (IMRAN) 28 June 1994, see entire document.	1-51
<input type="checkbox"/> Further documents are listed in the continuation of Box C. <input type="checkbox"/> See patent family annex.		
* Special categories of cited documents:	"T"	later document published after the international filing date or priority date and not in conflict with the application but cited to understand the principle or theory underlying the invention
"A" document defining the general state of the art which is not considered to be of particular relevance	"X"	document of particular relevance; the claimed invention cannot be considered novel or cannot be considered to involve an inventive step when the document is taken alone
"E" earlier document published on or after the international filing date	"Y"	document of particular relevance; the claimed invention cannot be considered to involve an inventive step when the document is combined with one or more other such documents, such combination being obvious to a person skilled in the art
"L" document which may throw doubts on priority claim(s) or which is cited to establish the publication date of another citation or other special reason (as specified)	"&"	document member of the same patent family
"O" document referring to an oral disclosure, use, exhibition or other means		
"P" document published prior to the international filing date but later than the priority date claimed		
Date of the actual completion of the international search 11 SEPTEMBER 1996	Date of mailing of the international search report 02 OCT 1996	
Name and mailing address of the ISA/US Commissioner of Patents and Trademarks Box PCT Washington, D.C. 20231 Facsimile No. (703) 305-3590	Authorized officer <i>Diane L. Smith for</i> JOHN D. YASKO, JR. Telephone No. (703) 308-2986	