



(19) **United States**

(12) **Patent Application Publication**

Lee et al.

(10) **Pub. No.: US 2010/0192313 A1**

(43) **Pub. Date: Aug. 5, 2010**

(54) **MODULAR STEEL BRIDGE**

(30) **Foreign Application Priority Data**

(76) Inventors: **Dae-Yong Lee**, Seoul (KR);
Jin-Kook Kim, Daejeon (KR);
Byung-Ho Choi, Suwon-shi (KR);
Chan-Hee Park, Yongin-Shi (KR);
Min-Oh Hwang, Yongin-Shi (KR);
Tae-Yang Yoon, Seongnam-Si (KR)

Aug. 17, 2006 (KR) 10-2006-0077857
Aug. 17, 2006 (KR) 10-2008-0077858

Publication Classification

(51) **Int. Cl.**
E01D 1/00 (2006.01)
E01D 2/00 (2006.01)
E01D 2/02 (2006.01)
E01D 2/04 (2006.01)

Correspondence Address:
**GIFFORD, KRASS, SPRINKLE, ANDERSON &
CITKOWSKI, P.C**
PO BOX 7021
TROY, MI 48007-7021 (US)

(52) **U.S. Cl.** **14/69.5**

(21) Appl. No.: **12/377,738**

(57) **ABSTRACT**

(22) PCT Filed: **Aug. 16, 2007**

A modular steel bridge is configured by combining at least two steel girder segments, and it includes a bearing block installed to be connected to an upper flange of a connection end of each steel girder segment and a web, and a hinge assembly installed to be attachable to the lower flange of each connection end and hinge-connecting the connection ends.

(86) PCT No.: **PCT/KR07/03916**

§ 371 (c)(1),
(2), (4) Date: **Feb. 17, 2009**

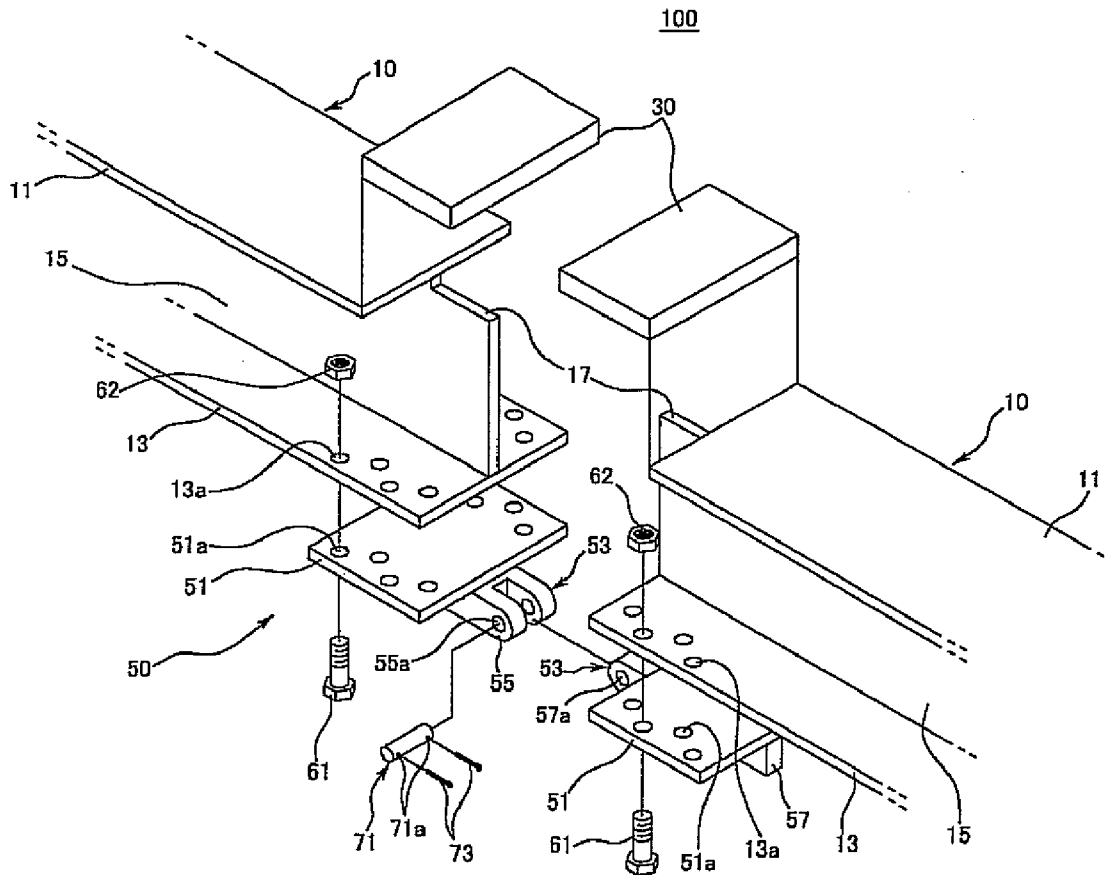

[FIG. 1]

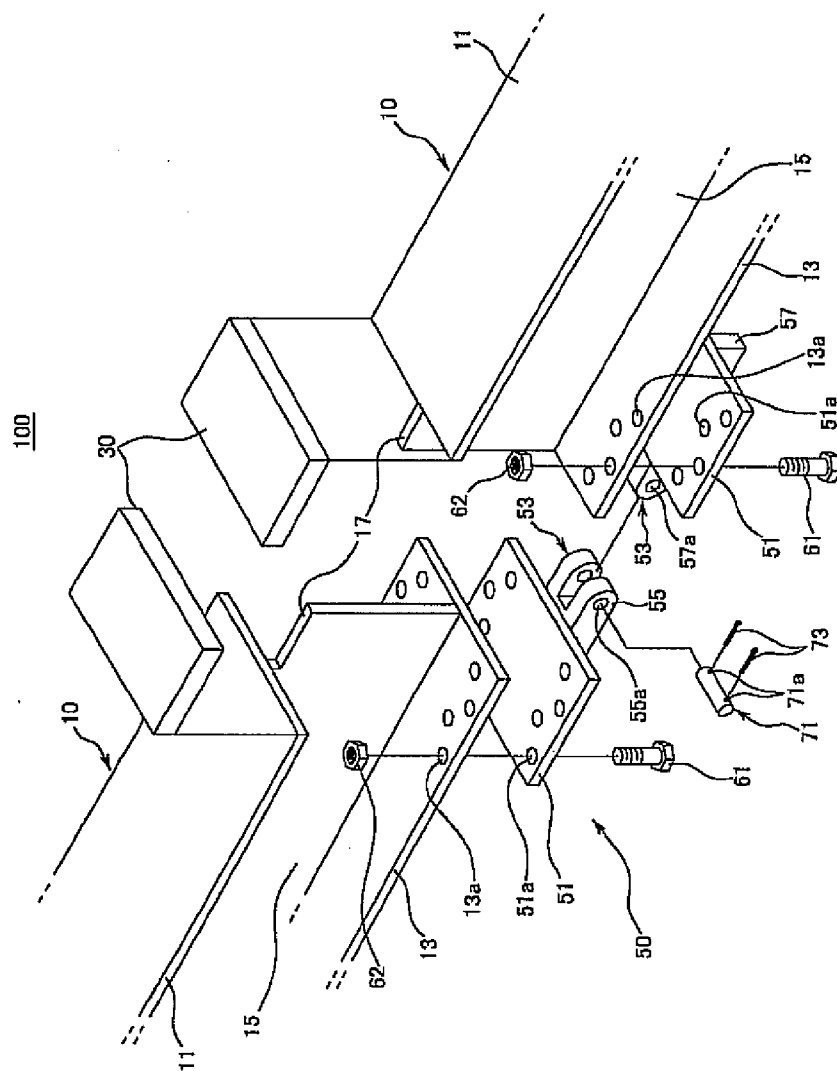

[FIG. 2]

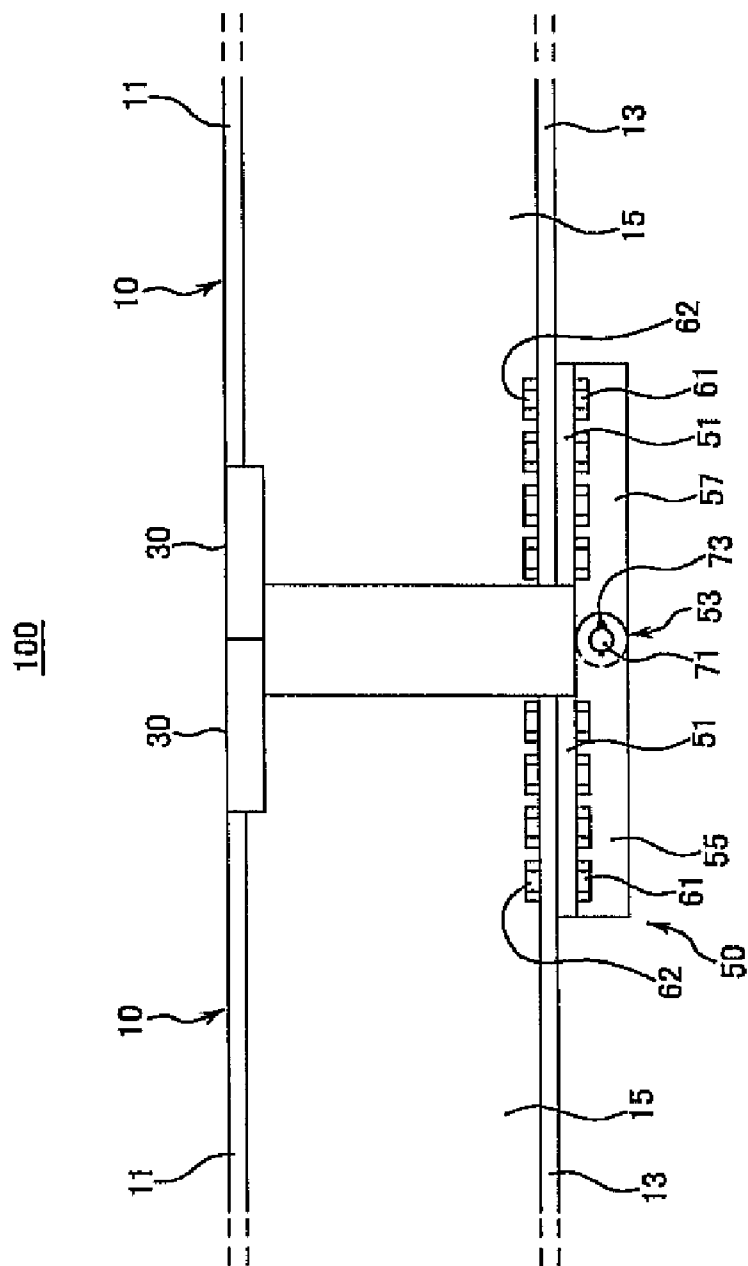

[FIG. 3]

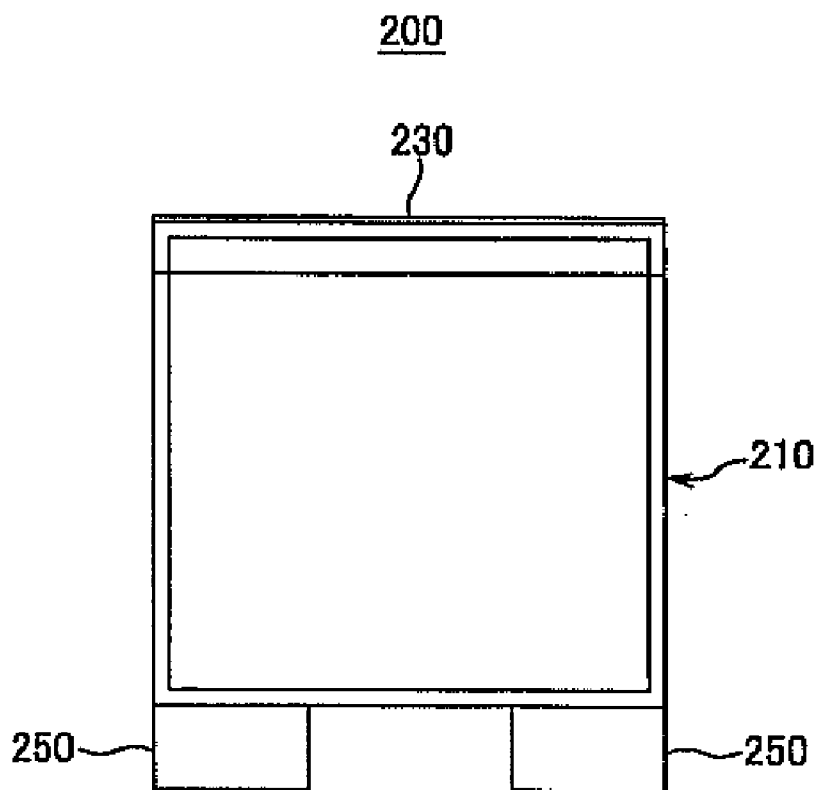

【FIG. 4】

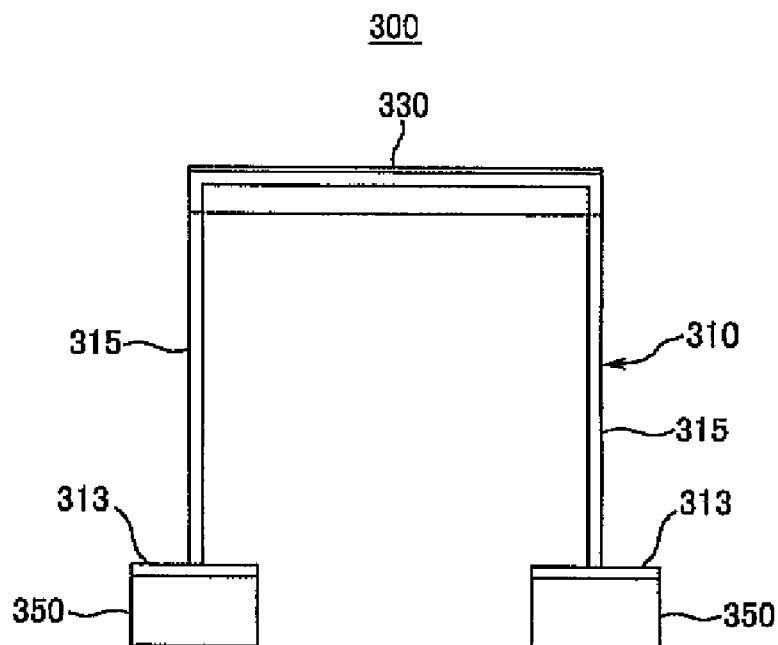

[FIG. 5]

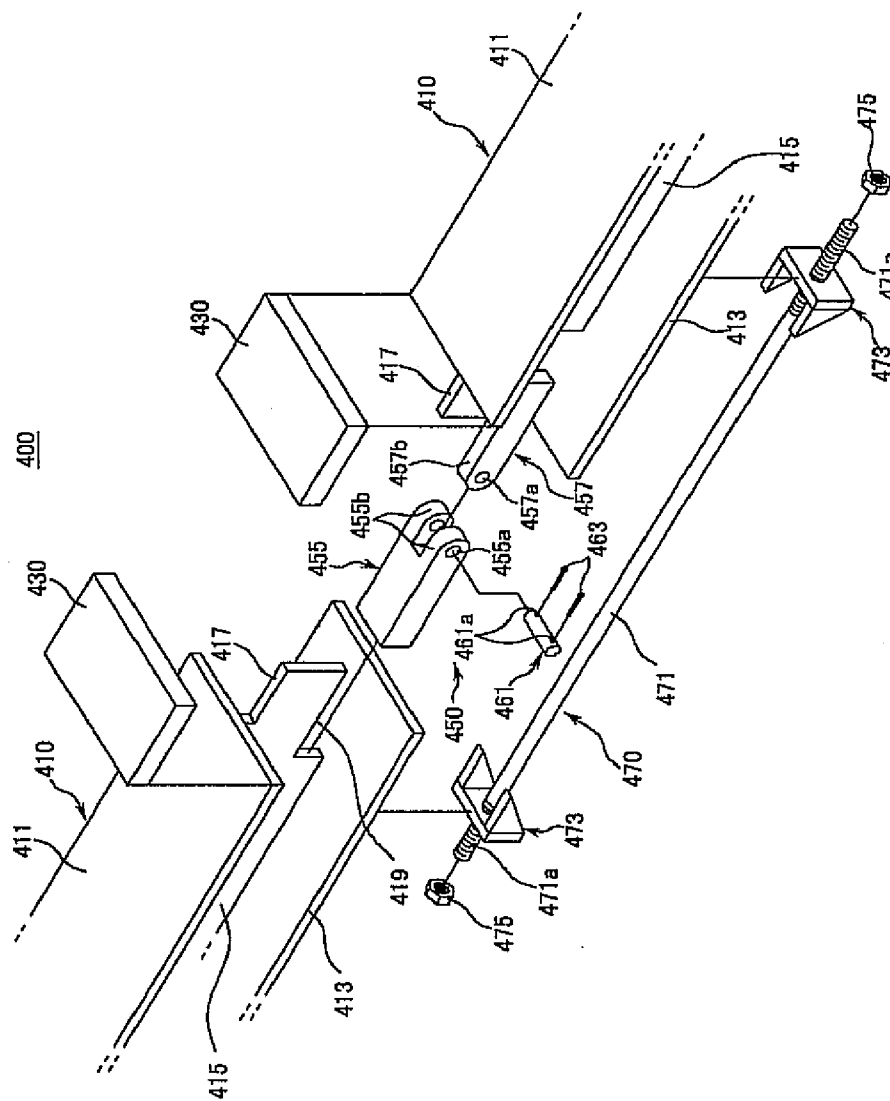

[FIG. 6]

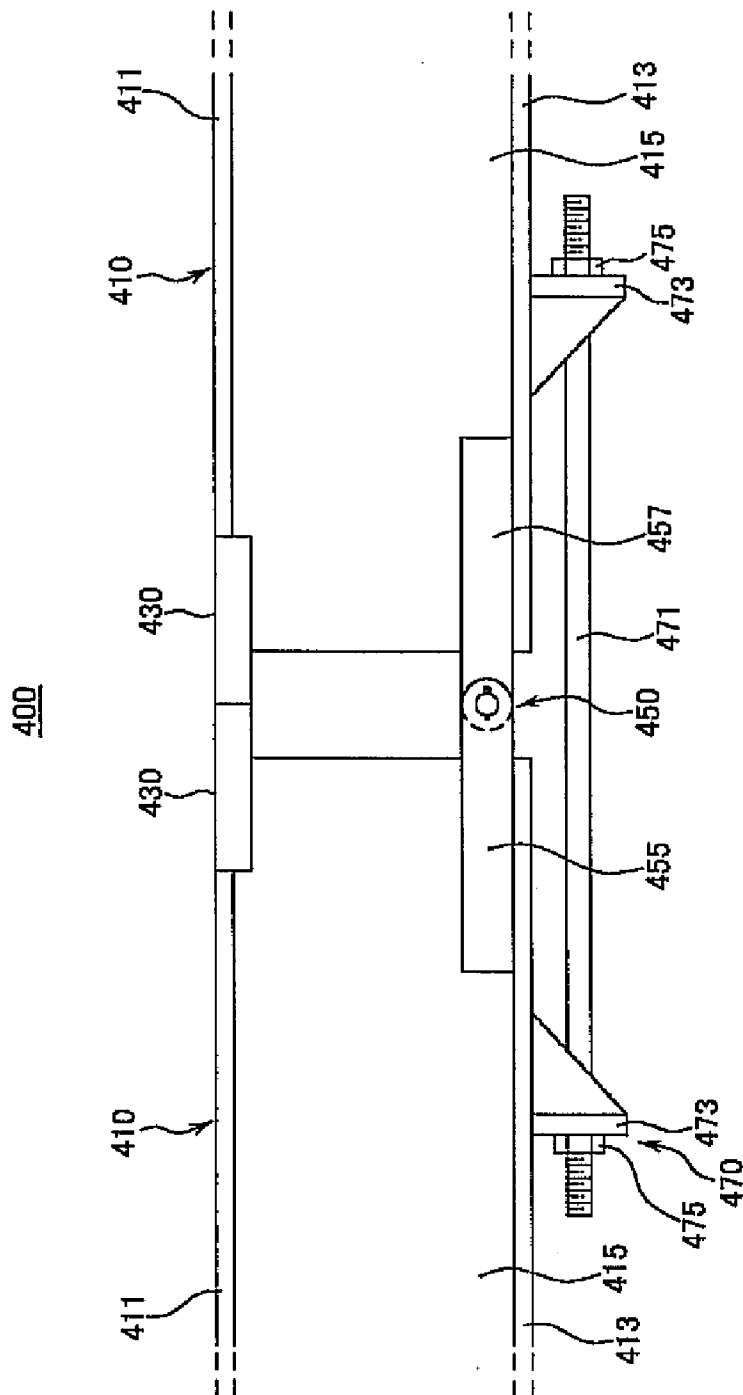

[FIG. 7]

500

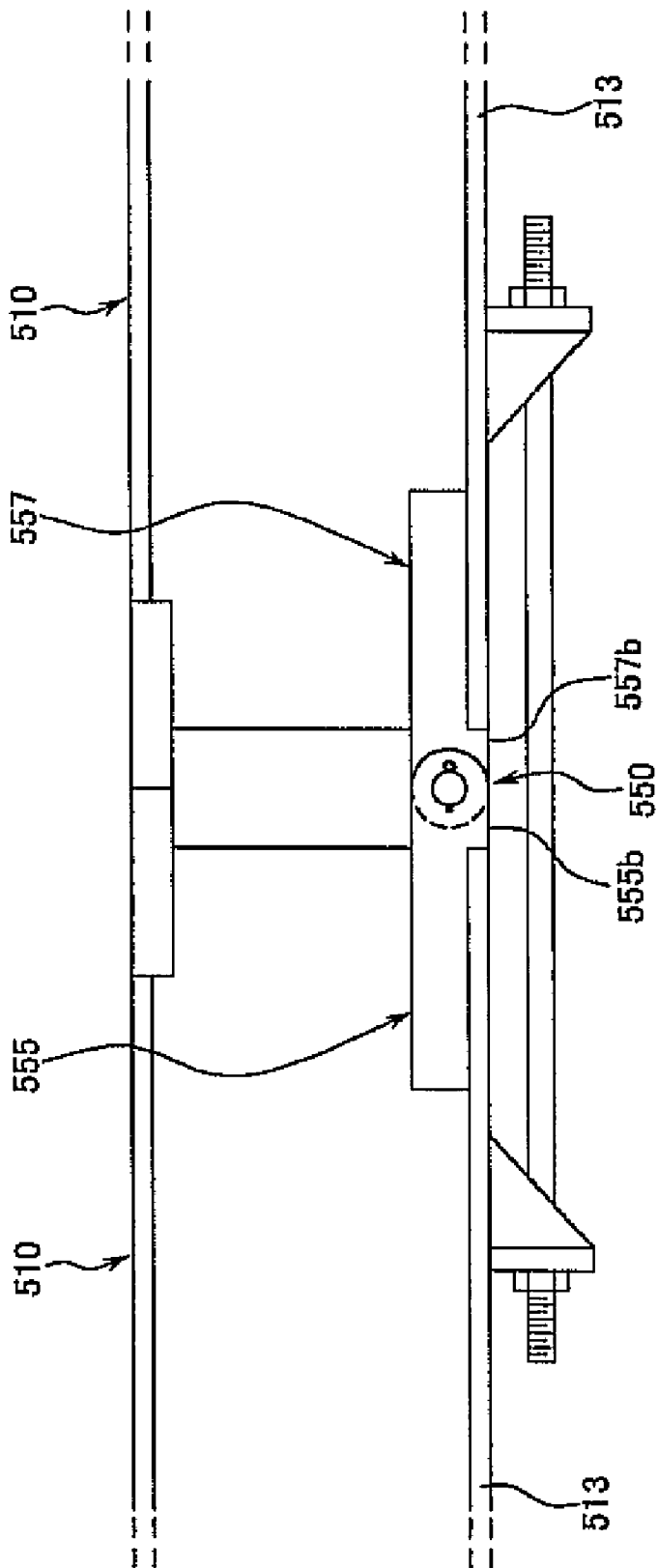

[FIG. 8]

600

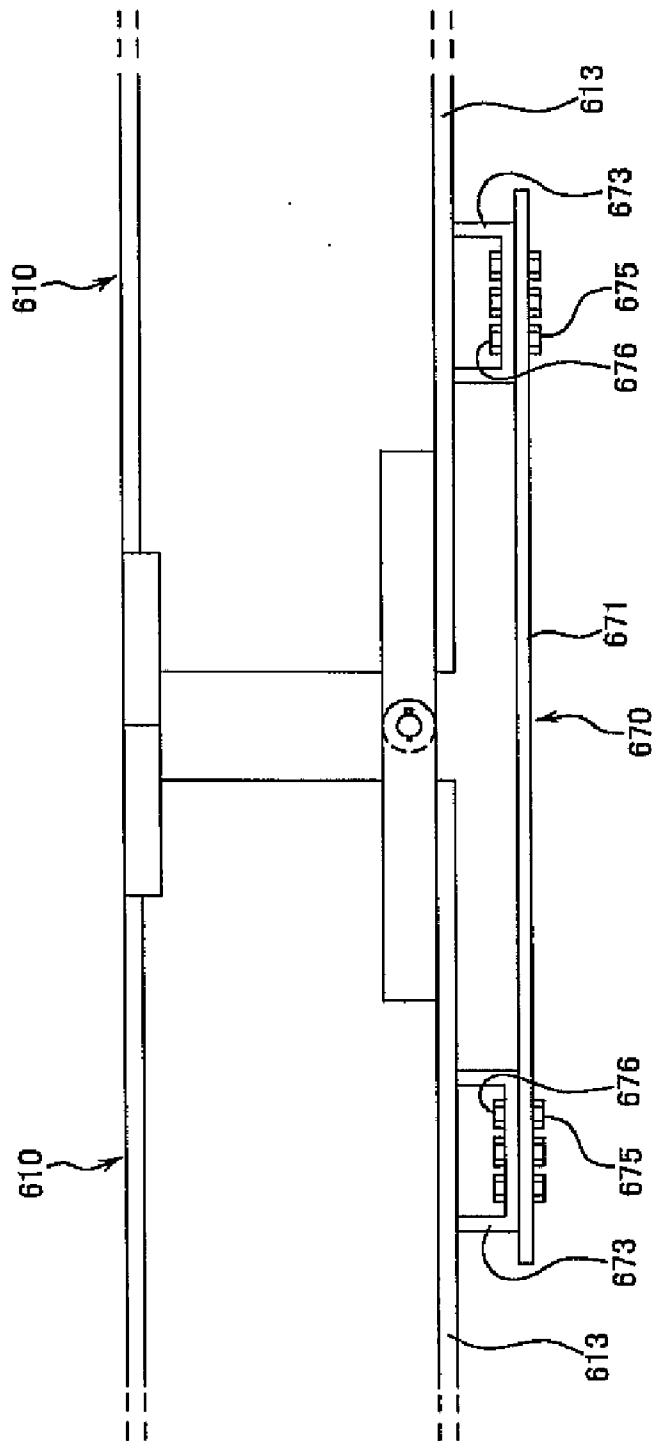

[FIG. 9]

700

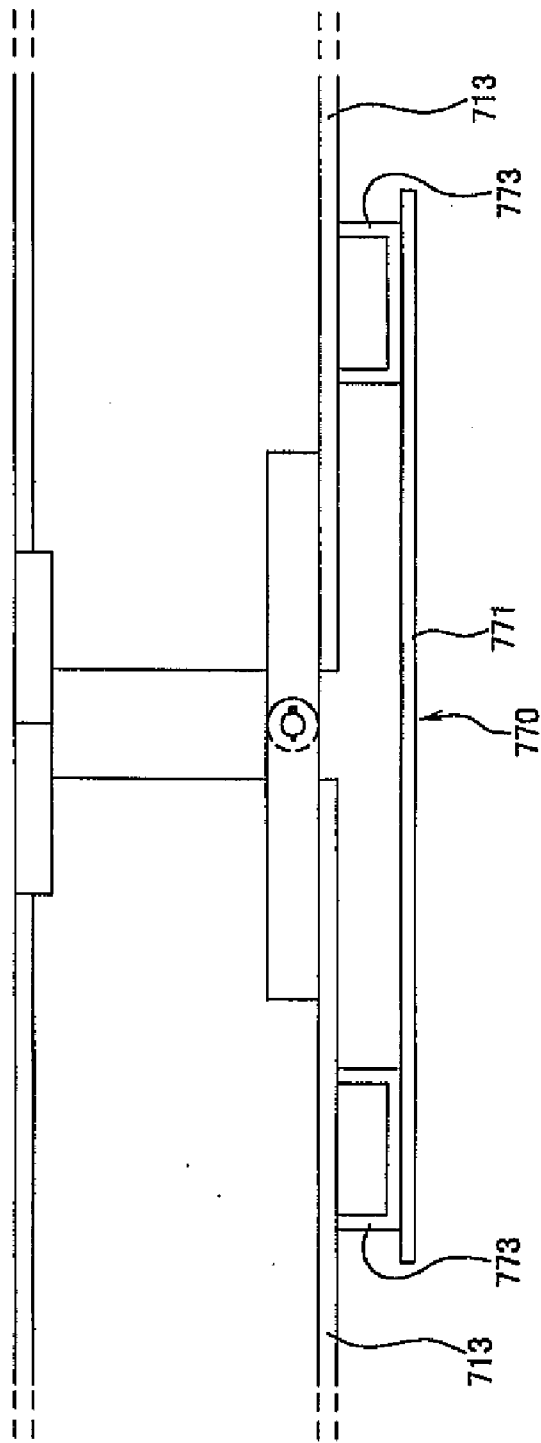

[FIG. 10]

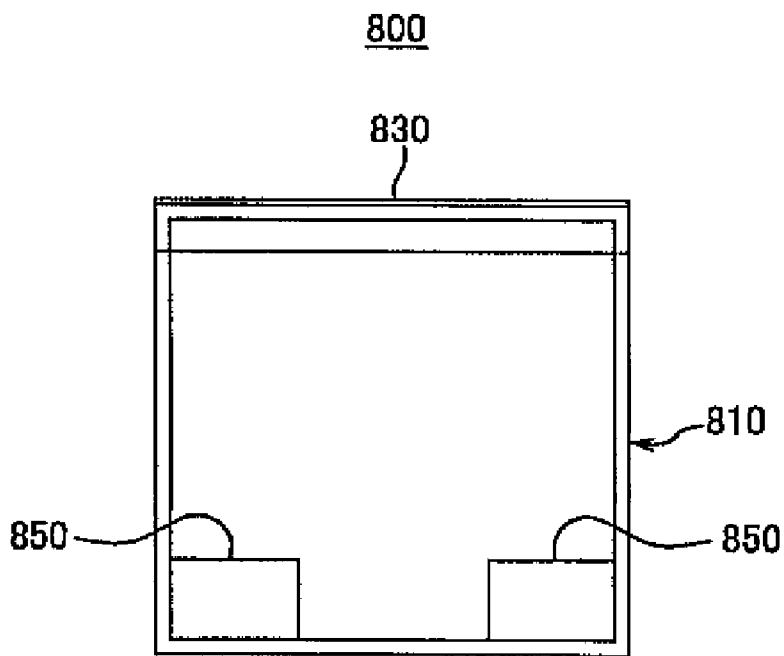

[FIG. 11]

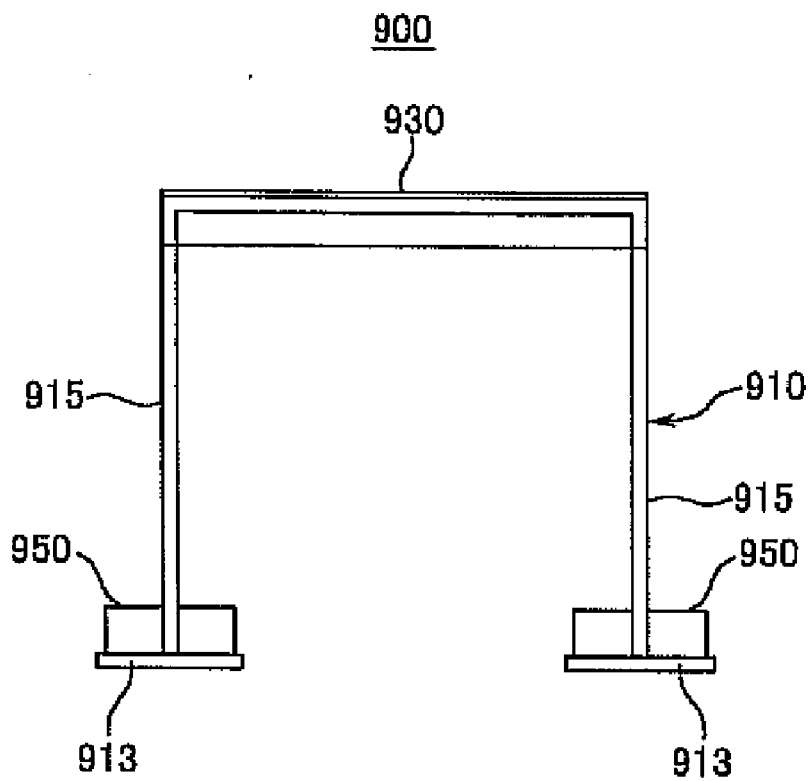

MODULAR STEEL BRIDGE

BACKGROUND OF THE INVENTION

[0001] (a) Field of the Invention

[0002] The present invention relates to a modular steel bridge. More particularly, the present invention relates to a modular steel bridge that is generated by connecting steel girder segments in a hinge format.

[0003] (b) Description of the Related Art

[0004] In general, a modular steel bridge is a temporary bridge in the simple bridge or continuous bridge format, and it has a structure in which at least two steel girder segments are connected as a single body.

[0005] The steel girders are generally manufactured as segments so as to increase the conveyance limit and increase installation convenience, and the segments are generally connected by welds or bolts at the construction site.

[0006] Regarding constructing the modular steel bridge, connection of girder segments by welding improves appearance of the entire structure compared to connection by bolts, and simultaneously reduces the overall steel amount since it requires no splice plate.

[0007] However, the on-the-spot welding has a large generation frequency of defects, it is difficult to improve defect parts, and it may greatly influence temporary precision because of shrinkage of the welded structure. Also, it has a drawback of increasing the amount of nondestructive inspection because of the reliability of the on-the-spot welding.

[0008] The connection of girder segments by bolts is less influenced by a technician's skillfulness and job conditions than connection by welding, it is relatively easy to control the quality of connected parts, and hence it is the most frequently used.

[0009] However, it takes much time to engage a plurality of bolts at the construction site, and the introduced axial force of the bolt is greatly changed by the engagement method and engagement order. Particularly, in the case of a friction joint, since members are connected by using frictional force of the contacting surface, close attention is required so as to acquire the friction coefficient of the steel surface.

[0010] Connection specifications of the hinge structure have been recently developed so as to improve resolution of the problems of welding connection and bolt connection of girder segments and to apply the connection specifications at an area that requires rapid construction such as for an emergency bridge.

[0011] The connection specifications result in a structure that can resist a load applied to the compression unit of a girder segment through a predetermined reinforcing member, and that can resist a load applied to the tensile unit of the girder segment through a hinge structure.

[0012] However, as the hinge structure of the modular steel bridge having the above-noted connection specification structure is connected to the connection part of the girder segment through welding, fatigue failure can be easily generated at the welded part by repeated loads during use of the girder.

[0013] Also, when a crack occurs in the hinge structure, it is impossible to repair the cracked part and reconstruction of the entire girder is needed.

[0014] In addition, the modular steel bridge having the above-noted connection specification has a problem of manufacturing the hinge structure by using an ultra-thick plate with

a thickness of greater than 100 mm so as to resist the tensile force applied to the hinge structure.

[0015] It is difficult to buy the ultra thick plates from domestic shops in Korea, but it is possible to manufacture the hinge structure through casting and forging as a substitute for the ultra thick plate, which however is not a desirable solution since the production cost is substantially increased.

[0016] Further, the modular steel bridge having the conventional hinge-structured connection specification has a less stable structure, and hence, when the hinge structure generates a crack as a result of repeated loads, the girder structure may dramatically fail.

[0017] The above information disclosed in this Background section is only for enhancement of understanding of the background of the invention and therefore it may contain information that does not form the prior art that is already known in this country to a person of ordinary skill in the art.

SUMMARY OF THE INVENTION

[0018] The present invention has been made in an effort to provide a modular steel bridge having advantages of preventing fatigue failure that occurs at a welded part of the girder segment and the hinge structure, and allowing easy partial repair of a hinge structure in which a crack is generated.

[0019] The present invention has been made in another effort to provide a modular steel bridge having advantages of reducing the design thickness of a hinge structure to be less than 100 mm and dividing a tensile force mainly applied to the hinge structure under the loading,

[0020] In one aspect of the present invention, a modular steel bridge configured by connecting at least two steel girder segments includes a bearing block installed to be connected to an upper flange of a connection end of the steel girder segment and a web, and a hinge assembly that is installed to be attachable to a lower flange of the connection end for hinge-combining the connection end.

[0021] The hinge assembly includes a connecting plate installed to be connected to the lower flange of the connection end by using bolts and nuts, and a combining member fixedly installed at the connecting plate and complementarily hinge-combined by a hinge pivot.

[0022] The lower flange of the connection end and the connecting plate are formed with a plurality of bolt holes.

[0023] The combining member includes a first hinge plate being fixedly installed at one connecting plate and having a pair of combining holes to which the hinge pivot is combined, and a second hinge plate being fixedly installed at another connecting plate, having a combining hole to which the hinge pivot is combined, and being combined with the first hinge plate in a concavo-convex manner.

[0024] The hinge pivot is formed with pin holes into which hinge pins are inserted at both ends thereof.

[0025] The connecting plate is installed to be connected to the bottom part of the lower flange, and the combining member is installed to be fixed to the bottom part of the connecting plate.

[0026] In another aspect of the present invention, a modular steel bridge configured by connecting at least two steel girder segments includes a bearing block installed at a connection end of a steel girder segment, a hinge assembly installed at the connection end, and a reinforcing unit installed to be connected to the connection end and dividing a tensile force applied to the hinge assembly.

[0027] The bottom part of the web of the connection end is cut to a predetermined height, and the hinge assembly is installed to be fixed at the cutting part of the web and the top part of the lower flange.

[0028] The hinge assembly includes: a first hinge plate installed to be fixed at the cutting part of the web of the connection end of one steel girder segment and the top part of the lower flange, and having a pair of combining holes to which a hinge pivot is combined; and a second hinge plate installed to be fixed at the cutting part of the web of the connection end of the other steel girder segment and the top part of the lower flange, having a combining hole to which the hinge pivot is combined, and being combined with the first hinge plate in the concavo-convex manner.

[0029] The hinge pivot has pin holes into which hinge pins are inserted at both ends thereof.

[0030] The first hinge plate and the second hinge plate include a combining unit to which the hinge pivot is combined.

[0031] The combining unit protrudes outside each connection end and is extended between the lower flanges.

[0032] The reinforcing unit includes a steel rod installed to be connected to the lower flanges of the connection ends.

[0033] The reinforcing unit includes a fixing member being installed at each lower flange of the connection ends and supporting respective ends of the steel rod, and a nut combined to each end of the steel rod.

[0034] The reinforcing unit includes a steel plate installed to be connected to each lower flange of the connection ends.

[0035] The reinforcing unit includes a connecting member being installed at each lower flange and supporting the steel plate.

[0036] The steel plate is installed to be connected to each connecting member by using bolts and nuts.

[0037] The steel plate is installed to be welded and fixed to each connecting member.

[0038] A bearing block is fixedly installed to the upper flange of each connection end and each web.

[0039] The connection ends of the steel girder segments are arranged with a gap therebetween, and the bearing blocks are installed to contact each other.

[0040] The bearing blocks are installed to protrude into a gap space between the connection ends.

[0041] The upper flange of each connection end is cut to a predetermined length, and the top part of the web of each connection end is cut to a predetermined height.

[0042] Each bearing block is formed to be thicker than the upper flange, and is welded and fixed at the cutting parts of the upper flange and the web.

[0043] Each steel girder segment includes one of an I-type girder, a box girder, and a Π -type girder.

BRIEF DESCRIPTION OF THE DRAWINGS

[0044] Subsequent drawings are provided to be referred to for the description of an exemplary embodiment of the present invention, and the scope of the present invention is not to be restricted by the accompanying drawings.

[0045] FIG. 1 is an exploded perspective view for a modular steel bridge according to a first exemplary embodiment of the present invention.

[0046] FIG. 2 is a front schematic diagram of FIG. 1.

[0047] FIG. 3 is a side schematic diagram for a modular steel bridge according to a second exemplary embodiment of the present invention.

[0048] FIG. 4 is a side schematic diagram for a modular steel bridge according to a third exemplary embodiment of the present invention.

[0049] FIG. 5 is an exploded perspective view for a modular steel bridge according to a fourth exemplary embodiment of the present invention.

[0050] FIG. 6 is a front schematic diagram of FIG. 5.

[0051] FIG. 7 is a front schematic diagram for a modular steel bridge according to a fifth exemplary embodiment of the present invention.

[0052] FIG. 8 is a front schematic diagram for a modular steel bridge according to a sixth exemplary embodiment of the present invention.

[0053] FIG. 9 is a front schematic diagram for a modular steel bridge according to a seventh exemplary embodiment of the present invention.

[0054] FIG. 10 is a side schematic diagram for a modular steel bridge according to an eighth exemplary embodiment of the present invention.

[0055] FIG. 11 is a side schematic diagram for a modular steel bridge according to a ninth exemplary embodiment of the present invention.

DETAILED DESCRIPTION OF THE EMBODIMENTS

[0056] The present invention will be described more fully hereinafter with reference to the accompanying drawings, in which exemplary embodiments of the invention are shown. As those skilled in the art would realize, the described embodiments may be modified in various different ways, all without departing from the spirit or scope of the present invention.

[0057] FIG. 1 is an analyzed perspective view for a modular steel bridge according to a first exemplary embodiment of the present invention, and FIG. 2 is a front schematic diagram of FIG. 1.

[0058] Referring to the drawings, the modular steel bridge 100 is a temporary bridge in the simple bridge or continuous bridge format, and has a structure in which at least two steel girder segments 10 are connected with each other.

[0059] The steel girder segments 10 are manufactured in a factory in advance, are delivered to the construction site, and are then connected.

[0060] Here, each steel girder segment 10 includes an upper flange 11, a lower flange 13, and a web 15 for connecting the flanges 11 and 13.

[0061] In this instance, each steel girder segment 10 is provided as an I-type girder in which the upper flange 11 and the lower flange 13 are arranged in parallel at the top part and the bottom part of the web 15 that is arranged in the vertical direction.

[0062] The modular steel bridge 100 includes a bearing block 30 that is installed to be connected to a connection end of each steel girder segment 10, and a hinge assembly 50 attachable to the connection ends so that the connection ends of the steel girder segments 10 may be hinge-connected.

[0063] In the modular steel bridge 100, the connection ends of the steel girder segments 10 are disposed with a gap therebetween, the bearing blocks 30 are provided to contact each other, and the connection ends of the steel girder segments 10 are hinge-combined by the hinge assembly 50.

[0064] The bearing blocks 30 resist a compressive force applied at the connection parts of the steel girder segments 10.

[0065] Each bearing block 30 is a metal plate having the same width as the upper flange 11 of the steel girder segment 10 and a greater thickness than that of the upper flange 11.

[0066] The bearing block 30 is installed to be fixed with the upper flange 11 of the connection end of the steel girder segment 10 and the web 15.

[0067] For this, a fixture unit 17 is formed at the upper flange 11 of the connection end of the steel girder segment 10 and the web 15. The fixture unit 17 includes a part that is generated by cutting the upper flange 11 of the connection end of the steel girder segment 10 to a predetermined length and a part that is generated by cutting the top part of the web 15 to a predetermined height.

[0068] In this instance, the bearing block 30 has a greater length than the cutting part of the web 15 and is arranged on the fixture unit 17.

[0069] Therefore, the bearing block 30 is welded and fixed to the upper flange 11 and the web 15 while being arranged on the fixture unit 17.

[0070] Since the bearing blocks 30 have a greater length than that of the cutting part of the web 15, the bearing blocks 30 partially protrude into the gap space between the connection ends of the steel girder segments 10 and contact each other.

[0071] The hinge assembly 50 resists the tensile force applied to the connection parts of the steel girder segments 10.

[0072] The hinge assembly 50 includes a connecting plate 51 that is installed to be connected to the lower flange 13 of the connection end of a steel girder segment 10, a combining member 53 that is installed to be fixed to the connecting plate 51, and a hinge pivot 71 for hinge-combining the combining members 53.

[0073] The connecting plate 51 includes a metal plate having a predetermined length and having the same width as the lower flange 13.

[0074] The connecting plate 51 is installed to be connected to the bottom of the lower flange 13, and is engaged with the lower flange 13 by bolts 61 and nuts 62.

[0075] For this, a plurality of bolt holes 51a for engaging the bolts 61 are formed in the connecting plate 51.

[0076] In correspondence to this, the lower flange 13 has a plurality of bolt holes 13a that correspond to the bolt holes 51a in the connecting plate 51. The combining member 53 has a form of a plate or a block, desirably has the form of a plate, and is welded and fixed on the center of the bottom of the connecting plate 51.

[0077] In detail, the combining member 53 includes a first hinge plate 55 that is fixedly installed on the bottom of one connecting plate 51, and a second hinge plate 57 that is fixedly installed on the bottom of the other connecting plate 51 for each steel girder segment 10.

[0078] The first hinge plate 55 is formed with a pair of combining parts to which the hinge pivot 71 is combined.

[0079] The combining parts are separately formed with a gap therebetween, and are formed to protrude into the gap space between the connection ends of the steel girder segments 10.

[0080] Each combining part is formed with a combining hole 55a into which the hinge pivot 71 can be inserted.

[0081] The second hinge plate 57 is combined with the first hinge plate 55 in the concavo-convex manner, and integrally has a combining part to which the hinge pivot 71 is combined.

[0082] The combining part is inserted between the combining parts of the first hinge plate 55, and is formed to protrude into the gap space between the connection ends of the steel girder segment 10 in a like manner of the first hinge plate 55.

[0083] The combining part includes a combining hole 57a into which the hinge pivot 71 can be inserted.

[0084] In the drawing, the non-described reference numeral 71a indicates pin holes that are formed at both ends of the hinge pivot 71, and reference numeral 73 shows hinge pins that are combined with the pin holes 71a of the hinge pivot 71.

[0085] Regarding the building process of the modular steel bridge 100, the fixture unit 17 of the connection end of each steel girder segment 10 made in the factory is welded to the bearing block 30.

[0086] In addition to this, the connecting plate 51 to which the first hinge plate 55 is welded is engaged by the bolts 61 and the nuts 62 on the lower flange 13 of the connection end of one steel girder segment 10.

[0087] Also, the connecting plate 51 to which the second hinge plate 57 is welded is engaged by the bolts 61 and the nuts 62 on the lower flange 13 of the connection end of one steel girder segment 10.

[0088] When the steel girder segments 10 are delivered to the construction site, the operator inserts the combining part of the second hinge plate 57 between the combining parts of the first hinge plate 55 to match the combining holes 55a and 57a of the first hinge plate 55 and the second hinge plate 57.

[0089] The hinge pivot 71 is combined with the combining holes 55a and 57a of the first hinge plate 55 and the second hinge plate 57, and hinge pins 73 are inserted into the pin holes 71a of the hinge pivot 71.

[0090] Therefore, through the above-described assemble process, the girder structure having the connected steel girder segments 10 as a body is generated, and the modular steel bridge 100 according to the exemplary embodiment of the present invention is completed by mounting the girder structure to form the bridge.

[0091] FIG. 3 is a side schematic diagram for a modular steel bridge according to a second exemplary embodiment of the present invention.

[0092] Referring to FIG. 3, the modular steel bridge 200 includes a box girder as a steel girder segment 210.

[0093] A bearing block 230 is installed to be fixed on the top part of the connection end of the steel girder segment 210, and a pair of hinge assemblies 250 are connected the bottom part of the connection end.

[0094] FIG. 4 is a side schematic diagram for a modular steel bridge according to a third exemplary embodiment of the present invention.

[0095] Referring to FIG. 4, the modular steel bridge 300 includes a Π -type girder as a steel girder segment 310.

[0096] The steel girder segment 310 includes a pair of webs 315, the top parts of the webs 315 are connected to a steel plate, and the bottom parts thereof are connected to lower flanges 313.

[0097] The bearing block 330 is installed to be fixed at the top part of the connection end of the steel girder segment 310, and a hinge assembly 350 is connected to the lower flange 313 of the connection end.

[0098] FIG. 5 is an analyzed perspective view for a modular steel bridge according to a fourth exemplary embodiment of the present invention, and FIG. 6 is a front schematic diagram of FIG. 5.

[0099] As shown, the modular steel bridge 400 includes a bearing block 430 installed at the connection end of each steel girder segment 410, a hinge assembly 450, and a reinforcing unit 470.

[0100] The modular steel bridge 400 is arranged so that connection ends of steel girder segments 410 may be arranged with a gap therebetween and are hinge-combined by the hinge assembly 450, the bearing blocks 430 are installed to contact each other, and a load applied to the hinge assembly 450 is shared with the reinforcing unit 470.

[0101] In this instance, the bearing block 430 will not be described since it corresponds to the configuration of the previous exemplary embodiment.

[0102] The hinge assembly 450 resists the tensile force applied to the connection part of the steel girder segment 410.

[0103] The hinge assembly 450 is installed to be fixed at a lower flange 413 of the connection end of each steel girder segment 410 and a web 415.

[0104] In detail, the hinge assembly 450 includes a first hinge plate 455 that is fixedly installed at the lower flange 413 of the connection end of one steel girder segment 410 and the web 415, and a second hinge plate 457 that is fixedly installed at the lower flange 413 of the connection end of the other steel girder segment 410 and the web 415.

[0105] In addition to this, the hinge assembly 450 includes a hinge pivot 461 for hinge-combining the first hinge plate 455 and the second hinge plate 457.

[0106] In this instance, the first hinge plate 455 and the second hinge plate 457 are respectively installed and welded to be fixed at the top surface of the lower flange 413 of the connection end of each steel girder segment 410 and web 415.

[0107] For this, the web 415 of the connection end of each steel girder segment 410 forms an accepting unit 419 for arranging the first hinge plate 455 and the second hinge plate 457, respectively.

[0108] Each accepting unit 419 is formed by a space between a part that is generated by cutting the bottom part of the web 415 to a predetermined height and the lower flange 413.

[0109] Therefore, the first hinge plate 455 and the second hinge plate 457, while being arranged in the respective accepting units 419, are welded and fixed at the top surface of the lower flange 413 and the cutting part of the web 415.

[0110] The first hinge plate 455 integrally forms a pair of combining units 455b to which the hinge pivot 461 is combined.

[0111] The combining units 455b are formed with a gap therebetween, and protrude outside the connection end of one steel girder segment 410.

[0112] Each combining unit 455b has a combining hole 455a in which the hinge pivot 461 can be inserted.

[0113] The second hinge plate 457 is combined with the first hinge plate 455 in the concavo-convex manner, and integrally forms a combining unit 457b to which the hinge pivot 461 is combined.

[0114] The combining unit 457b is inserted between the combining units 455b of the first hinge plate 455, and protrude outside the connection end of the steel girder segment 410 in a like manner of the first hinge plate 455.

[0115] The combining unit 457b is formed with a combining hole 457a into which the hinge pivot 461 can be inserted.

[0116] In the drawing, the non-described reference numeral 461a indicates pin holes generated at both ends of the

hinge pivot 461, and reference numeral 463 indicates hinge pins that are combined to the pin holes 461a of the hinge pivot 461.

[0117] The reinforcing unit 470 shares the tensile force that is mainly applied to the hinge assembly 450. The reinforcing unit 470 includes a steel rod 471 that is installed to be connected to the lower flange 413 of the connection end of each steel girder segment 410, fixing members 473 for supporting respective ends of the steel rod 471, and nuts 475 that are screw-combined to each end of the steel rod 471.

[0118] The steel rod 471 receives a substantial part of the tensile force applied to the hinge assembly 450, and is arranged in the length direction of the steel girder segment 410 with the connection ends of the facing steel girder segments 410 at the center.

[0119] A screw thread 471a for engaging the nuts 475 is formed at each end of the steel rod 471.

[0120] The fixing member 473 is installed to be welded and fixed at the bottom part of the lower flange 413 of the connection end of each steel girder segment 410.

[0121] Each fixing member 473 is formed with a hole 473a into which an end of the steel rod 471 is inserted.

[0122] In this instance, as shown in the drawing, each fixing member 473 includes a vertical steel plate that is vertically fixed on the bottom of the lower flange 413, and a side steel plate of a triangular rib form that is fixedly installed at both ends of the vertical steel plate and the bottom of the lower flange 413.

[0123] However, the fixing member 473 can also be formed in a box form without being restricted to the above-described configuration.

[0124] Regarding the method for assembling the modular steel bridge 400 according to the exemplary embodiment of the present invention, the steel girder segments 410 are manufactured in the factory and are then delivered to the construction site.

[0125] In this instance, the bearing block 430 is welded on a fixture unit 417 of the connection end of each steel girder segment 410.

[0126] Further, the first hinge plate 455 is arranged at the accepting unit 419 of the connection end of one steel girder segment 410, and the first hinge plate 455 is welded on the top part of the lower flange 413 and a cutting part of the web 415.

[0127] Also, the second hinge plate 457 is arranged at the accepting unit 419 of the connection end of another steel girder segment 410, and the second hinge plate 457 is welded on the top part of the lower flange 413 and a cutting part of the web 415.

[0128] In addition to this, the fixing member 473 is welded on the bottom of the lower flange 413 of the connection end of each steel girder segment 410.

[0129] In this state, the combining holes 455a and 457a of the combining units 455b and 457b are matched by inserting the combining unit 457b of the second hinge plate 457 between the combining units 455b of the first hinge plate 455.

[0130] The hinge pivot 461 is combined with the combining holes 455a and 457a of the first hinge plate 455 and the second hinge plate 457, and the hinge pins 463 are inserted into the pin holes 461a of the hinge pivot 461.

[0131] The ends of the steel rod 471 are inserted into the holes 473a of the fixing members 473 such that both ends of the steel rod 471 are combined with the fixing member 473.

[0132] In this state, a nut 475 is combined with each end of the steel rod 471 and is then threaded thereon, and a girder

structure in which at least two steel girder segments **410** are integrally connected is completed.

[0133] Therefore, when the girder structure is lifted upward so that both ends of the girder structure form the bridge, the construction of the modular steel bridge **400** according to the exemplary embodiment of the present invention is finished.

[0134] Accordingly, since the modular steel bridge **400** has a reinforcing unit **470** that is installed to be connected to the lower flange **413** of the connection end of the steel girder segment **410**, the tensile force mainly applied to the hinge assembly **450** is shared and the design thickness of the hinge plate is reduced to be less than 100 mm, differing from the prior art.

[0135] FIG. 7 is a front schematic diagram for a modular steel bridge according to a fifth exemplary embodiment of the present invention.

[0136] As shown, the modular steel bridge **500** includes a hinge assembly **550** that is formed for a combining unit **555b** of a first hinge plate **555** and a combining unit **557b** of a second hinge plate **557** to be extended between lower flanges **513**.

[0137] In detail, the combining unit **555b** of the first hinge plate **555** and the combining unit **557b** of the second hinge plate **557** protrude outside the connection ends of the steel girder segments **510** and extend to an area between the lower flanges **513** in a like manner of the previous exemplary embodiment.

[0138] That is, the thickness of the combining units **555b** and **557b** of the first hinge plate **555** and the second hinge plate **557** is greater than the thickness of the other part excluding the combining units **555b** and **557b** by the thickness of the lower flange **513**.

[0139] Therefore, according to the modular steel bridge **500** of the exemplary embodiment of the present invention, the tensile force applied to the hinge assembly **550** is more efficiently resisted since the combining unit **555b** of the first hinge plate **555** and the combining unit **557b** of the second hinge plate **557** are formed to be extended between the lower flanges **513**.

[0140] The residual configurations and operations of the modular steel bridge **500** according to this exemplary embodiment of the present invention will not be described since they correspond to those of the previous exemplary embodiment.

[0141] FIG. 8 is a front schematic diagram for a modular steel bridge according to a sixth exemplary embodiment of the present invention.

[0142] As shown, the modular steel bridge **600** can include a reinforcing unit **670** including a steel plate **671** that is installed to be connected to the lower flange **613** of the connection end of each steel girder segment **610**.

[0143] The reinforcing unit **670** includes connecting members **673** for supporting respective ends of the steel plate **671**, and the connecting members **673** are installed to be welded and fixed at the bottom surface of the lower flanges **613** of the connection ends of the steel girder segments **610**.

[0144] In this instance, the steel plate **671** is integrally connected to the connecting members **673** by engagement of bolts **675** and nuts **676**.

[0145] The residual configurations and operations of the modular steel bridge **600** according to the exemplary embodiment of the present invention will not be described since they correspond to those of the previous exemplary embodiments.

[0146] FIG. 9 is a front schematic diagram for a modular steel bridge according to a seventh exemplary embodiment of the present invention.

[0147] Referring to the drawing, the modular steel bridge **700** can be configured with a reinforcing unit **770** in which a steel plate **771** is welded to connecting members **773** on the basis of the configuration of the previous exemplary embodiment.

[0148] In detail, the connecting members **773** are installed to be welded and fixed at the bottom part of lower flanges **713**, and the steel plate **771** is installed to be welded and fixed at the bottom part of the connecting members **773**.

[0149] The residual configurations and operations of the modular steel bridge **700** according to the exemplary embodiment of the present invention will not be described since they correspond to those of the previous exemplary embodiments.

[0150] FIG. 10 is a side schematic diagram for a modular steel bridge according to an eighth exemplary embodiment of the present invention,

[0151] Referring to the drawing, the modular steel bridge **800** includes a box girder as a steel girder segment **810**.

[0152] A bearing block **830** is installed to be fixed at the top part of the connection end of the steel girder segment **810** according to the exemplary embodiment of the present invention, and a pair of hinge assemblies **850** are installed to be fixed at the bottom part of the connection end.

[0153] FIG. 11 is a side schematic diagram for a modular steel bridge according to a ninth exemplary embodiment of the present invention,

[0154] Referring to the drawing, the modular steel bridge **900** can adopt a Π -type girder as a steel girder segment **910**.

[0155] The steel girder segment **910** includes a pair of webs **915**, a steel plate is integrally connected to the top part of the webs **915**, and a lower flange **913** is integrally connected to each bottom part thereof.

[0156] A bearing block **930** is installed to be fixed at the top part of the connection end of the steel girder segment **910**, and a hinge assembly **950** is installed to be fixed at each lower flange **913** of the connection end. While this invention has been described in connection with what is presently considered to be practical exemplary embodiments, it is to be understood that the invention is not limited to the disclosed embodiments, but, on the contrary, is intended to cover various modifications and equivalent arrangements included within the spirit and scope of the appended claims.

[0157] According to the exemplary embodiment of the present invention, it is possible to hinge-assemble steel girder segments by using bolts, thereby fundamentally preventing the danger of fatigue failure that occurs at a welding part of a steel girder segment and a hinge structure.

[0158] Also, since the hinge assembly is attachable to the steel girder segment, the steel girder segment can be reused. Further, when a crack occurs at the hinge assembly because of a repeated load while using the girder, the maintenance fee of the girder can be reduced since it is easy to exchange the cracked hinge assembly.

[0159] In addition, as a reinforcing unit for dividing the tensile force mainly applied to the hinge assembly is provided, there is no need to use a conventional ultra-thick plate for the hinge assembly to thereby reduce the production cost of the bridge.

[0160] Also, the stability of the structure against the tensile force mainly applied to the hinge assembly can be improved by using the reinforcing unit.

- 1. A modular steel bridge configured by connecting at least two steel girder segments, comprising:
 - a bearing block installed to be connected to an upper flange of a connection end of each steel girder segment and a web; and
 - a hinge assembly, installed to be attachable to a lower flange of the connection end, for hinge-combining the connection end.
- 2. The modular steel bridge of claim 1, wherein the hinge assembly includes:
 - a connecting plate installed to be connected to the lower flange of the connection end by using bolts and nuts; and
 - a combining member fixedly installed at the connecting plate and complementarily hinge-combined by a hinge pivot.
- 3. The modular steel bridge of claim 2, wherein the lower flange of the connection end and the connecting plate are formed with a plurality of bolt holes.
- 4. The modular steel bridge of claim 2, wherein the combining member includes:
 - a first hinge plate being fixedly installed at one connecting plate and having a pair of combining holes to which the hinge pivot is combined; and
 - a second hinge plate being fixedly installed at another connecting plate, having a combining hole to which the hinge pivot is combined, and being combined with the first hinge plate in a concavo-convex manner.
- 5. The modular steel bridge of claim 2, wherein the hinge pivot is formed with pin holes into which hinge pins are inserted at each end thereof.
- 6. The modular steel bridge of claim 2, wherein the connecting plate is installed to be connected to the bottom part of the lower flange, and the combining member is installed to be fixed to the bottom part of the connecting plate.
- 7. A modular steel bridge configured by connecting at least two steel girder segments, comprising:
 - a bearing block installed at a connection end of each steel girder segment;
 - a hinge assembly installed at the connection end; and
 - a reinforcing unit being installed to be connected to each connection end and dividing the tensile force applied to the hinge assembly.
- 8. The modular steel bridge of claim 7, wherein the bottom part of the web of the connection end is cut to a predetermined height, and the hinge assembly is installed to be fixed at the cutting part of the web and the top part of the lower flange.
- 9. The modular steel bridge of claim 8, wherein the hinge assembly includes:
 - a first hinge plate installed to be fixed at the cutting part of the web of the connection end of one steel girder segment and the top part of the lower flange, and having a pair of combining holes to which a hinge pivot is combined; and
 - a second hinge plate installed to be fixed at the cutting part of the web of the connection end of another steel girder segment and the top part of the lower flange, having a

- combining hole to which the hinge pivot is combined, and being combined with the first hinge plate in a concavo-convex manner.
- 10. The modular steel bridge of claim 9, wherein the hinge pivot is formed with pin holes into which hinge pins are inserted at each end.
- 11. The modular steel bridge of claim 9, wherein the first hinge plate and the second hinge plate include a combining unit to which the hinge pivot is combined.
- 12. The modular steel bridge of claim 11, wherein the combining unit protrudes outside the connection end and is extended between the lower flanges.
- 13. The modular steel bridge of claim 7, wherein:
 - the reinforcing unit includes a steel rod installed to be connected to the lower flange of each connection end.
 - 14. The modular steel bridge of claim 13, wherein the reinforcing unit includes:
 - a fixing member being installed at the lower flange of each connection end and supporting respective ends of the steel rod; and
 - a nut combined to each end of the steel rod.
 - 15. The modular steel bridge of claim 7, wherein the reinforcing unit includes a steel plate installed to be connected to the lower flange of each connection end.
 - 16. The modular steel bridge of claim 15, wherein the reinforcing unit includes a connecting member being installed at each lower flange and supporting the steel plate.
 - 17. The modular steel bridge of claim 16, wherein the steel plate is installed to be connected to each connecting member by using bolts and nuts.
 - 18. The modular steel bridge of claim 16, wherein the steel plate is installed to be welded and fixed to each connecting member.
 - 19. The modular steel bridge of claim 7, wherein the bearing block is fixedly installed to the upper flange of each connection end and web.
 - 20. The modular steel bridge of claim 1, wherein the connection ends of the steel girder segments are arranged with a gap therebetween, and the bearing blocks are installed to be contacted with each other.
 - 21. The modular steel bridge of claim 1, wherein the bearing blocks are installed to protrude into a gap space between the connection ends.
 - 22. The modular steel bridge of claim 1, wherein, regarding the steel girder segments,
 - the upper flange of each connection end is cut to a predetermined length, and the top part of the web of each connection end is cut to a predetermined height.
 - 23. The modular steel bridge of claim 1, wherein each bearing block is formed to be thicker than the upper flange, and is welded and fixed at the cutting parts of the upper flange and the web.
 - 24. The modular steel bridge of claim 1, wherein the steel girder segment is an I-type girder.
 - 25. The modular steel bridge of claim 1, wherein the steel girder segment is a box girder.
 - 26. The modular steel bridge of claim 1, wherein the steel girder segment is a Π -type girder.

* * * * *