

(12) STANDARD PATENT
(19) AUSTRALIAN PATENT OFFICE

(11) Application No. **AU 2006276711 B2**

(54) Title
Apparatus and method for loading a tread press

(51) International Patent Classification(s)
B29C 31/08 (2006.01)

(21) Application No: **2006276711** (22) Date of Filing: **2006.07.10**

(87) WIPO No: **WO07/018928**

(30) Priority Data

(31) Number	(32) Date	(33) Country
11/191,816	2005.07.28	US

(43) Publication Date: **2007.02.15**

(44) Accepted Journal Date: **2011.03.10**

(71) Applicant(s)
Societe De Technologie Michelin;Michelin Recherche et Technique S.A.

(72) Inventor(s)
Louchart, Theophile Henry;Papin, Bernard;Pike, William Gibbs

(74) Agent / Attorney
Watermark Patent and Trade Marks Attorneys, Level 2 302 Burwood Road, Hawthorn, VIC, 3122

(56) Related Art
US 3413174 A

(19) World Intellectual Property Organization
International Bureau



(43) International Publication Date
15 February 2007 (15.02.2007)

PCT

(10) International Publication Number
WO 2007/018928 A3

(51) International Patent Classification:
B29C 31/08 (2006.01)

PIKE, William Gibbs [US/US]; 1410 Highway 247, Belton, South Carolina 29627 (US).

(21) International Application Number:
PCT/US2006/027007

(74) Agent: DORITY & MANNING, P.A.; 55 Beattie Place, Suite 1600, Greenville, South Carolina 29601 (US).

(22) International Filing Date: 10 July 2006 (10.07.2006)

(81) Designated States (unless otherwise indicated, for every kind of national protection available): AE, AG, AL, AM, AT, AU, AZ, BA, BB, BG, BR, BW, BY, BZ, CA, CH, CN, CO, CR, CU, CZ, DE, DK, DM, DZ, EC, EE, EG, ES, FI, GB, GD, GE, GH, GM, HN, HR, HU, ID, IL, IN, IS, JP, KE, KG, KM, KN, KP, KR, KZ, LA, LC, LK, LR, LS, LT, LU, LV, LY, MA, MD, MG, MK, MN, MW, MX, MZ, NA, NG, NI, NO, NZ, OM, PG, PH, PL, PT, RO, RS, RU, SC, SD, SE, SG, SK, SL, SM, SY, TJ, TM, TN, TR, TT, TZ, UA, UG, US, UZ, VC, VN, ZA, ZM, ZW.

(25) Filing Language: English

(26) Publication Language: English

(30) Priority Data:
11/191,816 28 July 2005 (28.07.2005) US

(84) Designated States (unless otherwise indicated, for every kind of regional protection available): ARIPO (BW, GH, GM, KE, LS, MW, MZ, NA, SD, SL, SZ, TZ, UG, ZM, ZW), Eurasian (AM, AZ, BY, KG, KZ, MD, RU, TJ, TM), European (AT, BE, BG, CH, CY, CZ, DE, DK, EE, ES, FI, FR, GB, GR, HU, IE, IS, IT, LT, LU, LV, MC, NL, PL, PT, RO, SE, SI, SK, TR), OAPI (BF, BJ, CF, CG, CI, CM, GA, GN, GQ, GW, ML, MR, NE, SN, TD, TG).

(71) Applicants (for all designated States except US): MICHELIN RECHERCHE ET TECHNIQUE S.A. [CH/CH]; Route Louis-braille 10 Et 12, Ch-1763, Granges-paccot Switzerland (CH). SOCIETE DE TECHNOLOGIE MICHELIN [FR/FR]; 23, Rue Breschet, Fr-63000, Clermont-ferrand, France (FR).

(72) Inventors; and

(75) Inventors/Applicants (for US only): PAPIN, Bernard [FR/US]; 9 Shady Brook Lane, Greenville, South Carolina 29615 (US). LOUCHART, Theophile Henry [US/US]; 670 Newman Road, Roebuck, Rhode Island 29376 (US).

Published:
— with international search report

[Continued on next page]

(54) Title: APPARATUS AND METHOD FOR LOADING A TREAD PRESS

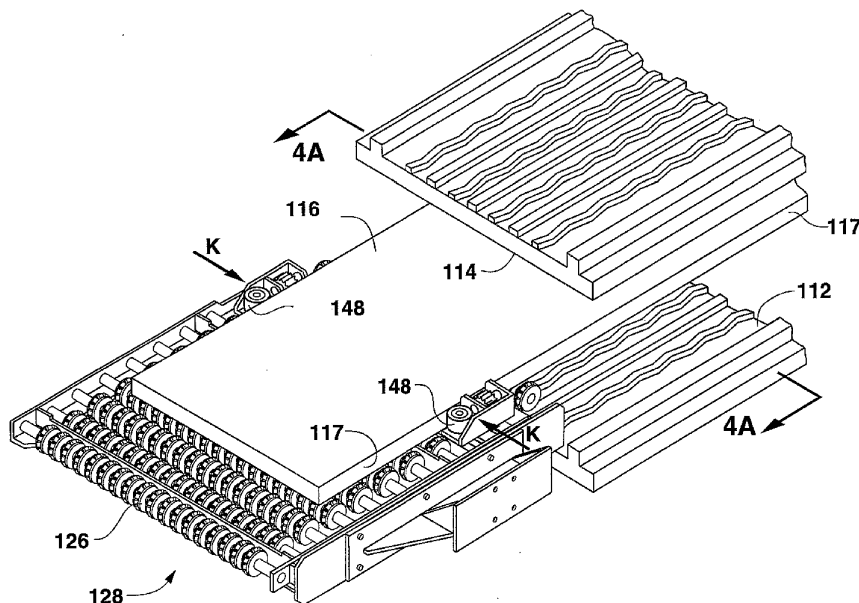

(57) Abstract: An apparatus and method for loading a tread press are provided. More specifically, the present invention provides for loading a tread band onto a tread press while suspending the tread band above the mold elements as the tread band is moved into the proper longitudinal position within the tread press. Lateral positioning can also be provided using the present invention.



WO 2007/018928 A3



— *before the expiration of the time limit for amending the claims and to be republished in the event of receipt of amendments*

For two-letter codes and other abbreviations, refer to the "Guidance Notes on Codes and Abbreviations" appearing at the beginning of each regular issue of the PCT Gazette.

(88) Date of publication of the international search report:

24 May 2007

PCT PATENT APPLICATION**TITLE****APPARATUS AND METHOD FOR LOADING A TREAD PRESS****TECHNICAL FIELD OF THE INVENTION**

[0001] The present invention provides an apparatus and method for loading a tread press. More specifically, the present invention provides for loading a tread band onto a tread press while suspending the tread band above the mold elements as the tread band is moved into the proper longitudinal position within the tread press. Lateral positioning can also be provided using the present invention.

BACKGROUND OF THE INVENTION

[0002] Retreaded tires are commercially available and provide an economical option to obtaining additional use of a tire after the tread has worn. The conventional process of retreading generally includes application of a length of tire tread, referred to herein as a tread band, to a tire casing from which the original tread band or a retread band has been removed. Prior to such application, the new tread band is manufactured by a process that includes providing tread features or tread sculpture to the tread band by means of a press operation.

[0003] Conventionally, the press is loaded by using a machine to drag the uncured tread band across the longitudinal length of the tread press until the tread is located in the proper longitudinal position. Lateral positioning of the uncured tread band in the tread press is

manually provided. Unfortunately, such conventional method can lead to a waste of material and manufacturing complexities. For example, because the tread band might be stretched as it is as dragged across the press, additional thickness is sometimes added to the tread band to compensate for the stretching. Even
5 with such compensation, such stretching may not occur uniformly along the length of the band. Improper lateral positioning may require discarding a certain section of the tread band. Manually checking and correcting the lateral position can be time and labor intensive.

[0004] Accordingly, it would be desirable to provide an automated apparatus
10 and method for loading a tread press that solves these and other complexities. An apparatus and method that further automates the tread loading process is also desirable. As will now be described, the present invention provides these and other advantages.

SUMMARY OF THE INVENTION

15 [0005] According to a first aspect of this invention there is provided a method of loading a tread press, the tread press having a top mold element and a bottom mold element, the tread press defining a longitudinal direction, the steps comprising:

providing at least one tread band for molding with the tread press;

20 providing at least one support that is initially located at a position that is not between the top and bottom mold elements;

contacting the tread band with the at least one support;

pulling the tread band between the top and bottom mold elements and
along the longitudinal direction while suspending the tread band over the bottom
25 mold element in a manner that inhibits permanent stretching of the tread band;

moving the support along the longitudinal direction and into a position
between the top and bottom mold elements while using the support to assist in
suspending the tread band over the bottom mold element;

stopping the movement of the tread band; and

30 removing the support along the longitudinal direction and out of the position between top and bottom mold elements while keeping the tread band between the top and bottom mold elements. In one exemplary method according to the present invention, such a method is provided for a tread press having a top mold

element and a bottom mold element, the tread press defining a longitudinal direction. This exemplary method includes providing at least one tread band for molding with the tread press, seizing a first end of the tread band, moving the tread band along the longitudinal direction into a position between the top and bottom mold elements while suspending the tread band over the bottom mold element, and lowering the tread band onto the bottom mold element. The method may include the additional steps of pulling the tread band in the longitudinal direction while suspending it above the bottom mold element, providing at least one support under and in contact with the tread band while pulling the tread band, and moving the at least one support longitudinally along with the tread band during the step of pulling the tread band. The support assists in the suspension of the tread band above the bottom mold element. The support may allow the tread band to be freely movable with respect to the support. A plurality of supports may be used to assist in suspending the tread band.

[0006] According to a further aspect, the present invention also provides a method of loading a tread press, the tread press having a top mold element and a bottom mold element, the tread press defining a longitudinal direction, the tread press defining a lateral direction that is perpendicular to the longitudinal direction, the steps comprising:

providing at least one tread band for molding with the tread press;
providing a plurality of movable support elements for suspending the tread band so as to inhibit deformation of the tread band by stretching;

contacting the tread band with the support elements while pulling the tread band longitudinally into a position between the top and bottom mold elements;

moving at least one of the support elements along the longitudinal direction and into a position between the top and bottom mold elements while using such support element to assist in suspending the tread band over the bottom mold element; and

removing the at least one support along the longitudinal direction and out of the position between top and bottom mold elements while keeping the tread band between the top and bottom mold elements.

In yet a further aspect, the present invention provides a method of loading a tread press with a tread band, the tread press having a top mold element and a bottom mold element, the tread press defining a longitudinal direction, the steps comprising:

- 5 providing a first support for the tread band, the first support initially located at a position that is not between the top and bottom mold elements;
- seizing a first end of the tread band;
- transporting the tread band along the longitudinal direction and across the first support so that a predetermined portion of the tread band hangs between the first end and the first support and is suspended directly over the bottom mold element;
- 10 moving the first support in synchronization with the transporting of the tread band and into a position between the top and bottom mold element; and
- lowering the tread band onto the bottom mold element. Various modifications and additional steps may be included. For example, a method of loading a tread press may include moving the at least one support after the tread band has been pulled for a predetermined distance. A step of laterally positioning the tread band may be included, which can also be performed during the step of lowering the tread band. The tread band may be pressed by moving the second mold element towards the first mold element. A second end of the tread band may be simultaneously moved with the second mold element during such pressing. Also, the exemplary methods just referenced may include the step of laterally positioning the tread band during the step of lowering the tread band. Also, the above exemplary methods may be used simultaneously for loading multiple tread bands onto a press having multiple such levels.
- 15 20 25

[0007] These and other features, aspects and advantages of the present invention will become better understood with reference to the following description and appended claims. The accompanying drawings, which are incorporated in and constitute a part of this specification, illustrate preferred embodiments of the invention and, together with the description, serve to explain the principles of the invention.

30

BRIEF DESCRIPTION OF THE DRAWINGS

[0008] A full and enabling disclosure of the present subject matter, including the best mode thereof, directed to one of ordinary skill in the art, is set forth in the specification, which makes reference to the appended figures, in which:

[0009] FIGS. 1A through 1G provide a schematic representation of an exemplary apparatus and method of the present invention as may be used for manufacturing a single layer of tread band.

[0010] FIGS. 2A through 2J, using an elevational view of another exemplary embodiment of the present invention, illustrate another exemplary method of the present invention as may be used for manufacturing multiple tread bands simultaneously.

[0011] FIG. 3 provides a perspective view of an element of the exemplary embodiment shown within FIGS. 2A through 2J.

[0012] FIGS. 4A and 4B provides a perspective view that depicts the operation of other elements of the exemplary embodiment shown within FIGS. 2A through 2J.

[0013] FIGS. 5A and 5B provide a cross-sectional view that depicts the operation of certain elements of the exemplary embodiment shown within FIGS. 2A through 2J and FIGS. 4A and 4B.

[0014] Repeat use of identical or similar reference characters throughout the present specification and appended drawings is intended to represent same or analogous features or elements of the invention.

DETAILED DESCRIPTION

[0015] Various features and advantages of the invention will be set forth in part in the following description, or may be obvious from the description. The present invention

provides an apparatus and method for loading a tread press that suspends the tread band above certain elements of the tread press until the tread band is properly positioned longitudinally along the length of the tread press. Elements for executing a lateral positioning step may also be provided.

[0016] In one exemplary embodiment a single-layer, tread band press 10 is provided as is illustrated in FIGS. 1A through 1G. Press 10 includes a mold element 12 and a mold back 14. Mold element 12 includes sculptures (represented schematically by a dashed-line) that create the tread features that are to be molded into tread band 16.

[0017] In one exemplary method according to the present invention, the process for loading tread band 16 into press 10 begins by pulling tread band 16 in the longitudinal direction or in a direction along the length of press 10 as is illustrated by arrow A in FIG. 1A. As shown, clamp 18 grabs a first end 20 of tread band 16 and pulls along longitudinal direction A. Note that due to a slight tension, tread band 16 remains suspended above mold element 12. More specifically, tread band 16 is not dragged across the surface 24 of mold element 12 but remains suspended above to prevent band 16 from being snagged or stretched. Tread band 16 is fed across rollers 26 on a first support 28, a second support 30, and a third support 32. It should be understood that the term suspended, as used in this specification, means that a tread band is supported over a mold element in a manner that reduces or minimizes the tension that would otherwise occur without suspension. Notably, it is within the spirit and scope of the present invention that some contact between the tread band and the mold element may still occur – i.e. the tread band may not be completely suspended at all points along its length. Nevertheless, the advantages of the present invention in reducing tension in the tread band can still be achieved in such embodiments.

[0018] After clamp 18 has carried first end 20 of tread band 16 a predetermined distance B (FIG. 1A), first support 28 also begins to move along the longitudinal direction of the machine as indicated by arrow C in FIG. 1B. Such movement with tread band 16 provides continued support and suspension of tread band 16 above mold element 12. Preferably, clamp 18 and first support 28 move substantially at the same speed in order to maintain predetermined distance B therebetween. However, it should be understood that the present invention includes embodiments where first support 28 and clamp 18 are moved at different speeds and times relative to one another.

[0019] Similarly, after first support 28 has moved a predetermined distance D (FIG. 1B), second support 30 begins to move along the longitudinal direction of the machine as indicated by arrow E to provide continued support and suspension of tread band 16. Second support 30 moves at substantially the same speed as first support 28 in order to maintain predetermined distance D therebetween. Once second support 30 has moved a predetermined distance F (FIG. 1C), third support 32 begins to move along the longitudinal direction of the machine as indicated by arrow G. As such, tread band 16 is now supported above mold element 12 in at least three positions: the first 28, second 30, and third 32 supports respectively. Using the teachings disclosed herein, one of ordinary skill in the art will appreciate that more or fewer supports may be used depending upon the weight and overall length of tread band 16.

[0020] Once the tread band 16 has been extended along the length of mold 10, supports 28, 30, and 32 are retracted as shown by arrows H in FIG. 1E. Each support is withdrawn sequentially and preferably at the same time until each are returned to the starting position shown in FIG. 1F. As supports 28, 30, and 32 are retracted, clamp 18 remains in place and holds tread band 16 in position. Additionally, as the supports are retracted, tread band 16

may remain in tension over mold element 12. However, as shown in FIG. 1F and depending upon its weight and length, tread band 16 falls into position on mold element 12 as the first support 28 is retracted. As will be discussed with another embodiment of the present invention to be later described, first support 28 ensures that tread band 16 is properly positioned laterally by guiding tread band 16 into place as first support 28 is withdrawn to its starting position as shown in FIG. 1E. Such lateral positioning may be accomplished, for example, using lateral alignment rollers as will be described later herein.

[0021] As depicted by arrow J in FIG 1G, tread band press 10 is now closed by lifting mold element 12 so as to press tread band 16 against mold back 14 and thereby impress tread band 16 with the desired tread features. In order to alleviate tension in tread band 16 at feed point 34, first support 28 is provided with a lift mechanism 36 by which rollers 26 on first support 28 can be lifted as shown by arrow I in FIG. 1G. Using the teachings disclosed herein, it will be understood by one of ordinary skill in the art that mold back 14 and mold element 12 can be switched such that mold back 14 is below tread band 16 and mold element 12 is above. These and other variations are within the scope of the present invention. Once tread band 16 has been molded, mold element 12 is lowered and tread band 16 is removed for further manufacturing.

[0022] As will now be described, the present invention may be utilized to mold multiple tread bands simultaneously using a press having multiple levels. Referring now to FIGS. 2A through 2J, a tread band press 110 is provided that can mold up to eight tread bands 116 simultaneously. Tread band press 110 is constructed with eight vertically distinct molding levels 113. Each level 113 includes a mold element 112 and a mold back 114. It is within the spirit and scope of the present invention to use a different number of levels and other mold press 110 configurations.

[0023] Press 110 includes clamp column 140, which carries eight clamps 118 with each at a different vertical level. Clamps 118 are each powered and controlled by a clamp control mechanism 142. As such, clamps 118 can be activated to simultaneously grab or select tread band 116. While a clamping type mechanism is preferred, other means of grasping or selecting the first end 120 of tread band 116 may be utilized.

[0024] As shown in FIGS. 2A through 2J, first support column 144 carries a series of first supports 128 that are selectively positionable at vertically distinct levels. Referring now to FIG. 4A, each first support 128 includes a series of multi-directional rollers 126 that allow tread band 116 to move across freely. Multiple rollers 126 are carried on a series of bars 146 that are placed in side-by-side fashion along the longitudinal direction MM of the machine. First support 128 also includes a pair of lateral alignment rollers 148. Each roller 148 can be adjusted for the width of tread band 116 using rack 150 and pinion 152. More specifically, rack 150 and pinion 152 moves with roller 148 to position roller 148 along slot 154 as shown by arrows K. Referring to FIG. 4B and 5A, as shown tread band 116 moves across and is supported by rollers 126 on first support 128, lateral alignment rollers 148 contact the sides 117 of tread band 116 to provide proper lateral positioning.

[0025] As shown in FIG. 3, first support column 144, which carries the series of first supports 128, rides along rollers 156 constrained within floor track 158. Locomotion is provided by motor 160, which moves first support column 144 along rail 162 using multiple rollers 164. Using the teachings disclosed herein, one of ordinary skill in the art will understand that a control system (not shown) can be used in conjunction with motor 160 to position first support column 144 as desired along with the length of the press 110.

[0026] In a manner similar to that which was previously discussed with regard to the exemplary method and embodiment of FIGS. 1A-1G, first support column 144 includes a

motor 166 and screw drive 168 (FIG. 2A) for powering the vertical movement of first supports 128 along first support column 144. As such, the vertical position of each first support 128 can be controlled to reduce the tension of tread band 116 when tread band press 110 is closed.

[0027] Referring again to FIGS. 2A through 2J, tread band press 110 also includes a second support column 170 that carries a series of second supports 130 that are positioned at vertically distinct levels. Similarly, press 110 includes a third support column 172 that carries a series of third supports 132 that are also positioned at vertically distinct levels. As with first supports 128 second and third supports 130 and 132 each have a series of rollers 126 carried on multiple bars 146 that allow tread band 116 to move thereon freely. As with first support column 144, second and third support columns 170 and 172 each are powered by a motor 160 that provides for the longitudinal positioning of these columns along press 110 using multiple rollers 164. Second and third support columns 170 and 172 also ride on rollers 156 in floor track 158. However, for the embodiment shown in the figures, second and third support columns 170 and 172 do not include motor 166 or screw drive 168. More specifically, the vertical position of the series of second and third supports 130 and 132 is fixed and is not selectively adjustable as with the series of first supports 128. It should be understood, however, that vertical adjustability may be provided if needed with either or both of second and third support columns 170 and 172.

[0028] An exemplary method of loading tread band press 110 will now be further described beginning with FIG. 2B. As shown therein, clamps 118 begin the process of loading press 110 by grasping first end 120 of each of the tread bands 116. Tread bands 116 are fed from a supply (now shown) through third support column 172, second support column 170, and first support column 144. Accordingly, as clamp column 140 pulls tread band 116 towards tread

band press 110, tread band 116 rolls freely across the multiple rollers 126 on each of the series of first, second, and third supports, 128, 130, and 132 respectively.

[0029] Referring now to FIG. 2C, clamp column 140 pulls multiple tread bands 116 into the mold levels 113 of tread band press 110 as indicated by arrow AA. As previously described, due to a slight tension, tread bands 116 remain suspended above mold elements 112. More specifically, tread bands 116 are not dragged across mold elements 112 but remain suspended above to prevent bands 116 from being snagged or stretched. Once clamp column 140 has moved a predetermined distance BB, first support column 144 begins to move towards tread band press 110, as indicated by arrow CC, in order to maintain the suspension of tread band 116 above mold elements 112. Preferably, clamp column 140 and first support column 144 move substantially at the same speed in order to maintain predetermined distance BB therebetween.

[0030] As shown in FIG. 2D, after first support column 144 has moved a predetermined distance DD, second support column 170 begins to move along the longitudinal direction of the machine as indicated by arrow EE to provide continued support and suspension of tread bands 116. Second support column 170 moves at substantially the same speed as first support column 144 in order to maintain predetermined distance DD therebetween. As with first support column 144, second support column 170 acts to maintain the suspension of tread bands 116 above mold elements 112 as clamp column 140 continues to pull additional length of tread bands 116 into tread band press 110.

[0031] Turning now to FIG. 2E, once second support column 170 moves a predetermined distance FF, third support column 172 begins to move along the longitudinal direction of the machine as indicated by arrow GG. Preferably, third support column 172 moves at substantially the same speed as second support column 170 in order to maintain

predetermined distance FF therebetween. As tread bands 116 continue to travel into tread band press 110, FIG. 2F illustrates that each tread band 116 is supported above a respective mold element 112 in at least three positions by the series of first 128, second 130, and third 132 supports respectively. Using the teachings disclosed herein, one of ordinary skill in the art will appreciate that more or fewer supports may be used depending upon the weight and overall length of tread bands 116.

[0032] Once tread bands 116 are extended along the length of tread band press 110, the series of first 128, second 130, and third supports 132 supports are withdrawn by the movement of the respective support columns 144, 170, and 172 as shown by arrows HH in FIG. 2G. Each support column is withdrawn sequentially and preferably at the same time until each are returned to the starting position shown in FIG. 2H. As supports 128, 130, and 132 are retracted, clamps 118 remain in place and hold tread bands 116 in place longitudinally. In a manner as previously described with regard to FIGS. 4A, 4B, and 5A, as first column 144 is retracted lateral alignment rollers 148 on each support 128 provide the proper lateral positioning of tread bands 116 while rolling along sides 117. As shown in FIG. 2H and depending upon the weight and length, tread bands 116 fall into position on mold element 12 as first support column 144 is retracted.

[0033] As depicted by arrow NN in FIG. 2I, tread band press 110 is now closed by lifting mold elements 112 using hydraulic lift mechanism 136. Such lifting presses tread bands 116 against mold backs 114 and thereby impresses tread bands 116 with the desired tread features as shown in FIG. 5B. In order to alleviate tension in tread bands 116 at feed point 134, the series of first supports 128 on first support column 144 are lifted using motor 166 and screw drive 168 as discussed above with regard to FIG. 3. Using the teachings disclosed herein, it will be understood by one of ordinary skill in the art that mold back 114 and mold element

112 can be switched such that mold back 114 is below tread band 116 and mold element 112 is above. These and other variations are within the scope of the present invention.

[0034] Turning now to FIG. J, after a proper mold time has elapsed, mold elements 112 are lowered (arrow PP) to release tread bands 116, which have been severed at second ends 122. Clamp column 140 then pulls tread bands 116 from tread band press 110 for further processing as indicated by arrow QQ. Clamp column 140 is then returned to the position illustrated in FIG. 2B where the process just described can be repeated.

[0035] Using the teachings disclosed herein, it will be understood that variations to the apparatus and method described above fall within the spirit and scope of the claims that follow. By way of examples only, a different number of support columns may be used as necessary. A different sequence or spacing between support columns may be used to provide a proper suspension of the tread band. Again, by way of example only, the support columns and clamp column may be moved at the same time and at different speeds, at different times and equal speeds, and a variety of other combinations that provide suspension. The lateral positioning may be accomplished using different methods or apparatus, including the positioning of lateral alignment rollers on different or multiple support columns. It should be understood that the present invention includes these and other various modifications that can be made to the exemplary embodiments of apparatus and method described herein that come within the scope of the appended claims and their equivalents.

THE CLAIMS DEFINING THE INVENTION ARE AS FOLLOWS:

1. A method of loading a tread press, the tread press having a top mold element and a bottom mold element, the tread press defining a longitudinal direction, the steps comprising:

5 providing at least one tread band for molding with the tread press;
providing at least one support that is initially located at a position that is not between the top and bottom mold elements;

contacting the tread band with the at least one support;

10 pulling the tread band between the top and bottom mold elements and along the longitudinal direction while suspending the tread band over the bottom mold element in a manner that inhibits permanent stretching of the tread band;

moving the support along the longitudinal direction and into a position between the top and bottom mold elements while using the support to assist in suspending the tread band over the bottom mold element;

15 stopping the movement of the tread band; and

removing the support along the longitudinal direction and out of the position between top and bottom mold elements while keeping the tread band between the top and bottom mold elements.

20 2. A method of loading a tread press as in claim 1, further comprising the step of sliding the tread band across the support during said step of removing the support.

3. A method of loading a tread press as in claim 1, wherein said step of moving the support is initiated after the tread band has been pulled for a predetermined distance.

25 4. A method of loading a tread press as in claim 1, further comprising the step of laterally positioning the tread band during said step of removing the support.

5. A method of loading a tread press as in claim 1, the tread press defining a transverse direction that is perpendicular to the longitudinal direction, the method

further comprising the step of moving the support along the transverse direction to adjust the position of the tread band.

6. A method of loading a tread press as in claim 1, further comprising the step of lowering the tread band onto the bottom mold element.

5 7. A method of loading a tread press as in claim 6, wherein said step of lowering the tread band occurs during said removing step.

8. A method of loading a tread press, the tread press having a top mold element and a bottom mold element, the tread press defining a longitudinal direction, the tread press defining a lateral direction that is perpendicular to the
10 longitudinal direction, the steps comprising:

providing at least one tread band for molding with the tread press;

providing a plurality of movable support elements for suspending the tread band so as to inhibit deformation of the tread band by stretching;

15 contacting the tread band with the support elements while pulling the tread band longitudinally into a position between the top and bottom mold elements;

moving at least one of the support elements along the longitudinal direction and into a position between the top and bottom mold elements while using such support element to assist in suspending the tread band over the bottom mold element; and

20 removing the at least one support along the longitudinal direction and out of the position between top and bottom mold elements while keeping the tread band between the top and bottom mold elements.

9. A method of loading a tread press with a tread band, the tread press having a top mold element and a bottom mold element, the tread press defining a
25 longitudinal direction, the steps comprising:

providing a first support for the tread band, the first support initially located at a position that is not between the top and bottom mold elements;

seizing a first end of the tread band;

30 transporting the tread band along the longitudinal direction and across the first support so that a predetermined portion of the tread band hangs between the

first end and the first support and is suspended directly over the bottom mold element;

moving the first support in synchronization with the transporting of the tread band and into a position between the top and bottom mold element; and

5 lowering the tread band onto the bottom mold element.

10. A method of loading a tread press as in claim 9, further comprising the step of maintaining the first support at a fixed position along the longitudinal direction during a portion of said transporting step.

11. A method of loading a tread press as in claim 9, further comprising the
10 step of preventing contact between the tread band and the bottom mold element during said transporting step.

12. A method of loading a tread press as in claim 9, further comprising the step of removing the first support from a position between the top and bottom mold elements during said lowering step.

15 13. A method of loading a tread press as in claim 9, further comprising the step of providing a second support that moves in synchronization with the movement of the tread band while supporting the tread band.

14. A method of loading a tread press as in claim 9, further comprising the step of laterally positioning the tread band.

20 15. A method of loading a tread press as in claim 14, where said step of laterally positioning the tread band occurs during said lowering the tread band step.

16. A method of loading a tread press as in claim 9, further comprising the step of moving the bottom mold element towards the top mold element.

25 17. A method of loading a tread press as in claim 16, wherein the tread band has a second end, and further comprising the step of moving the second end of

the tread band during said step of moving the bottom mold element towards the top mold element.

18. A method of loading tread press as in claim 9, wherein said transporting step comprises pulling the tread band from the first end.

5

**SOCIETE DE TECHNOLOGIE MICHELIN and MICHELIN RECHERCHE ET
TECHNIQUE S.A.**

WATERMARK PATENT & TRADE MARK ATTORNEYS

P29882AU00

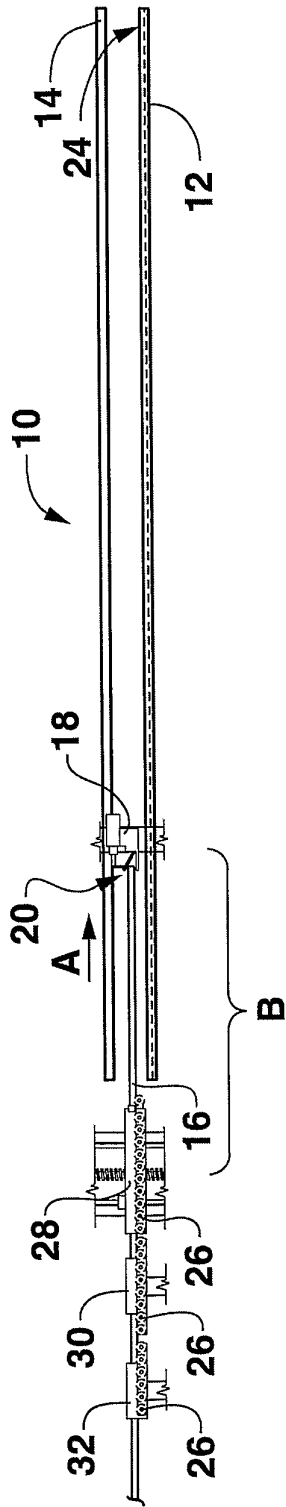

FIG. 1A

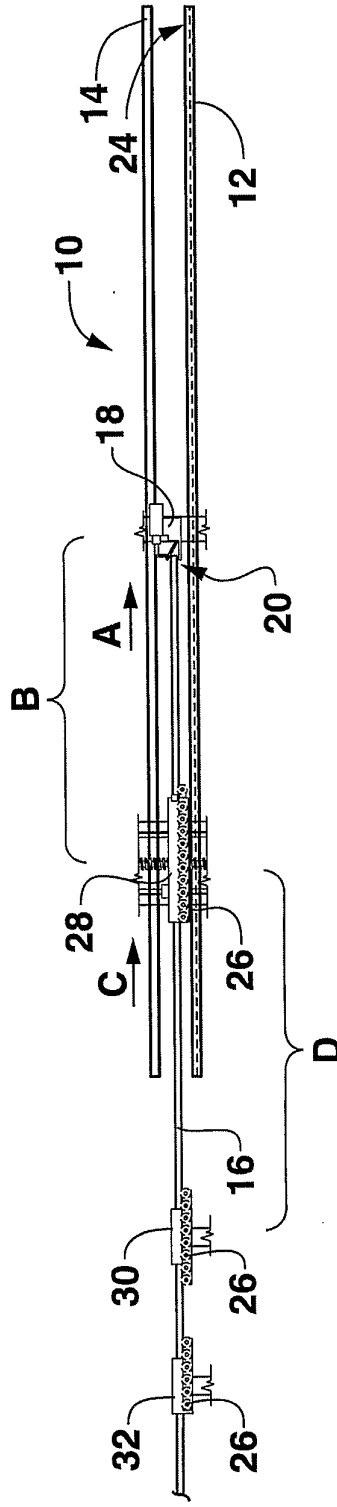

FIG. 1B

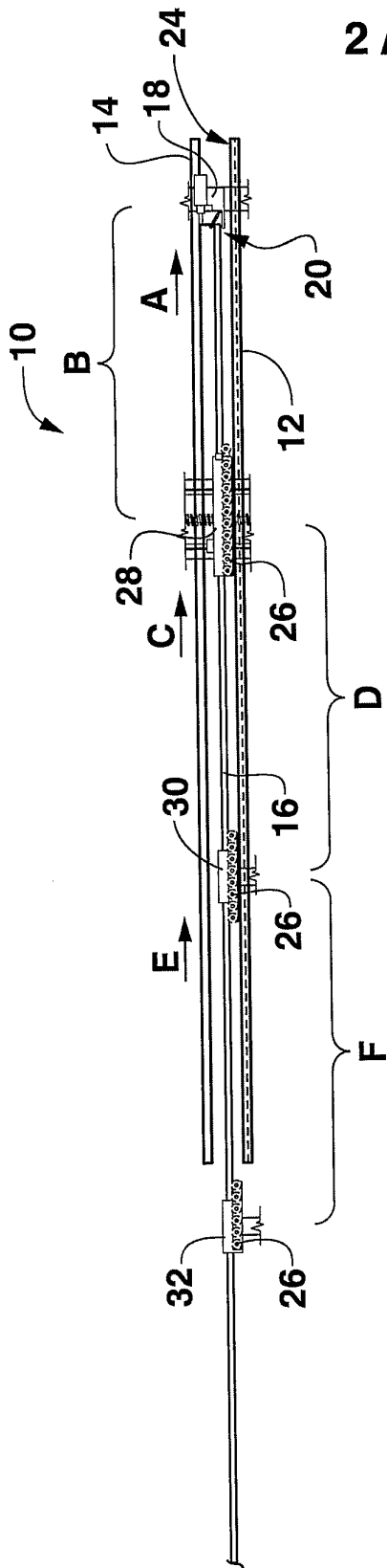

FIG. 1C

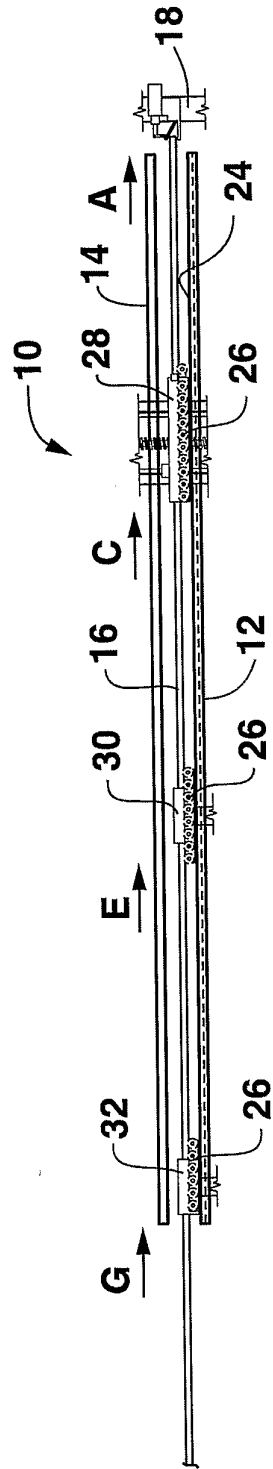

FIG. 1D

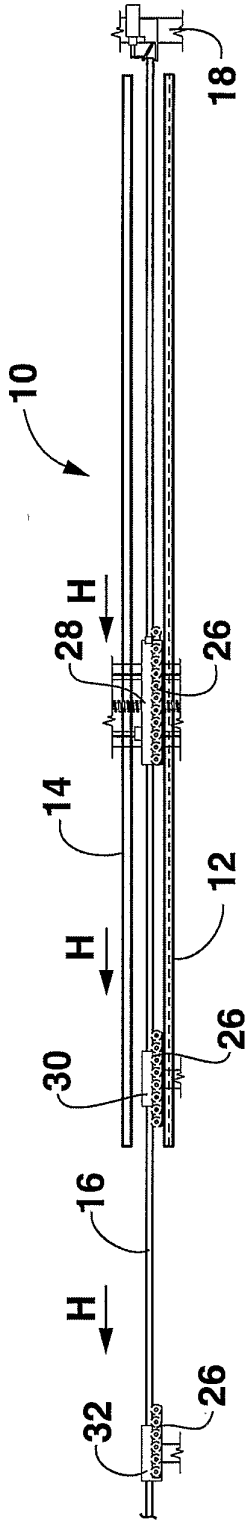

FIG. 1E

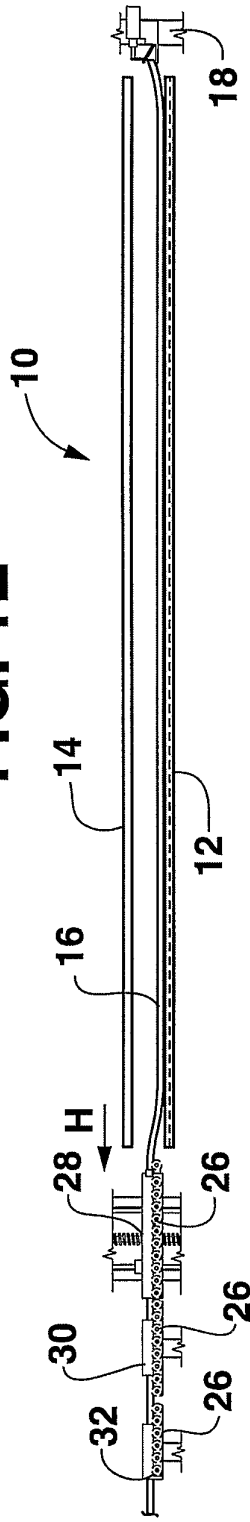

FIG. 1F

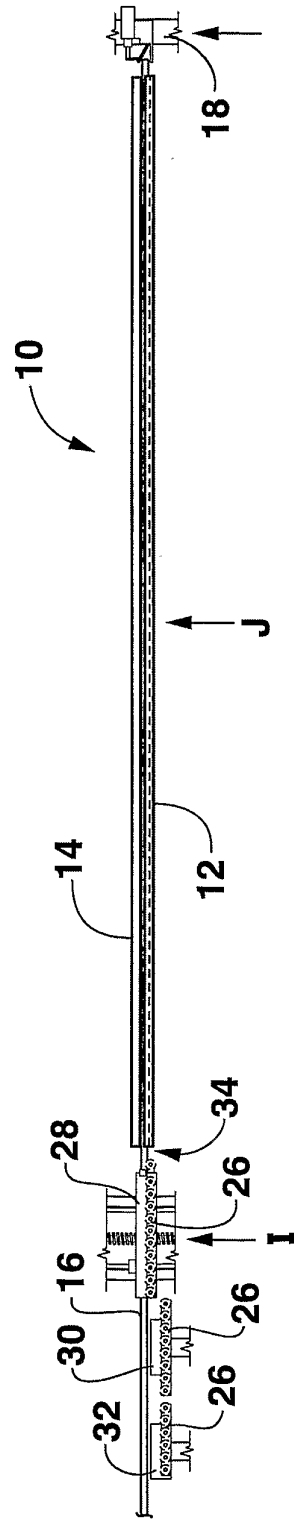

FIG. 1G

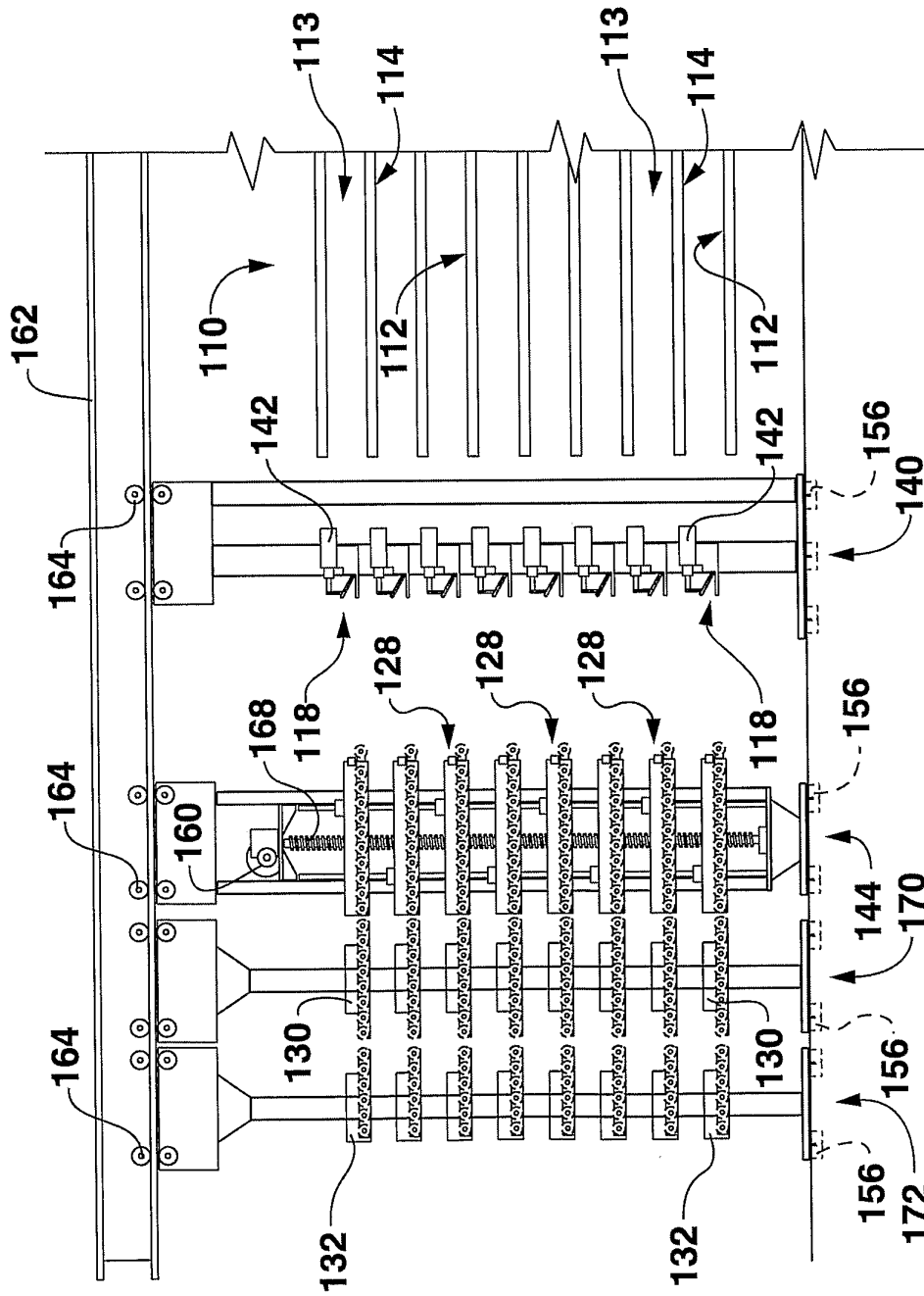

FIG. 2A

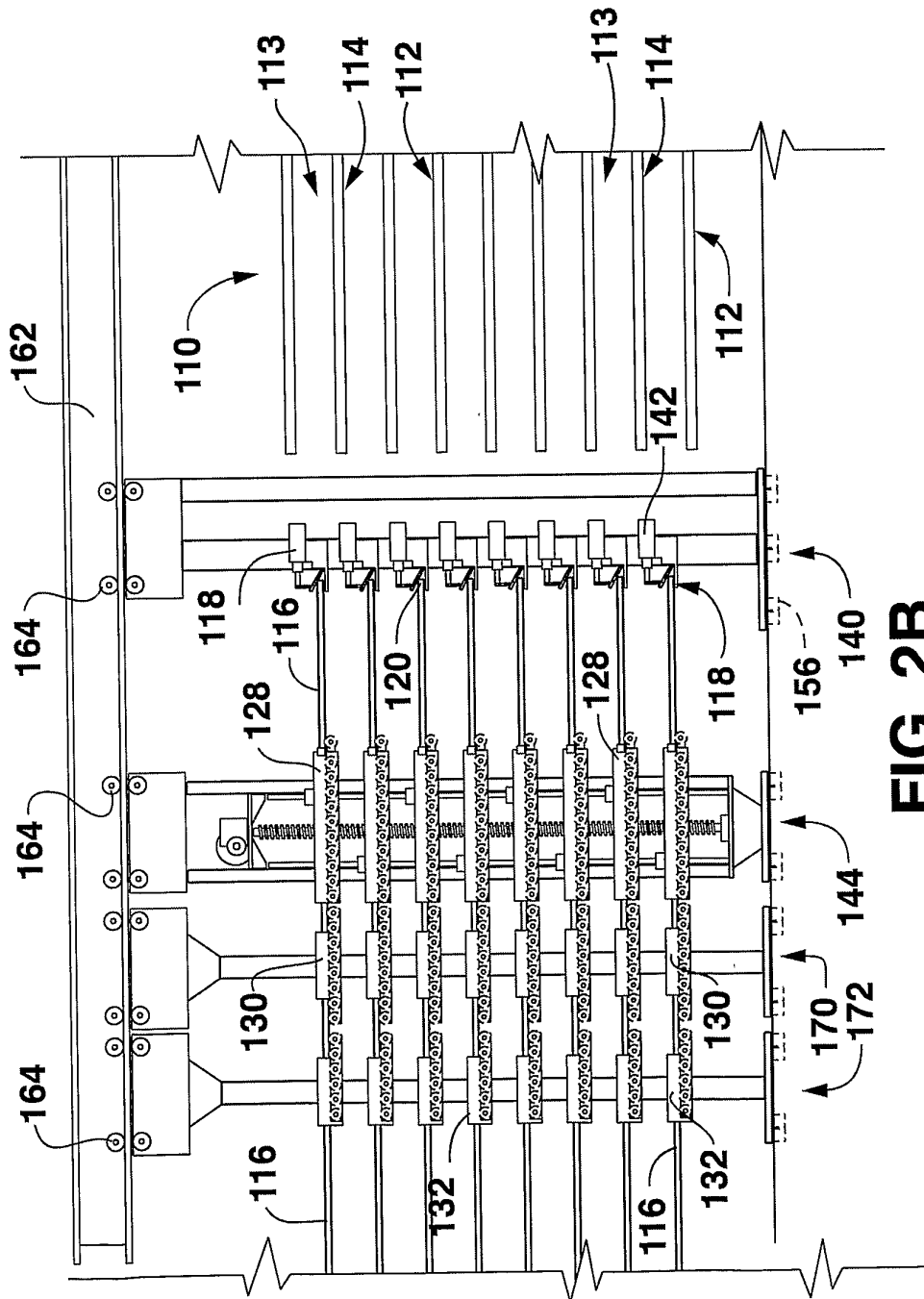

FIG. 2B

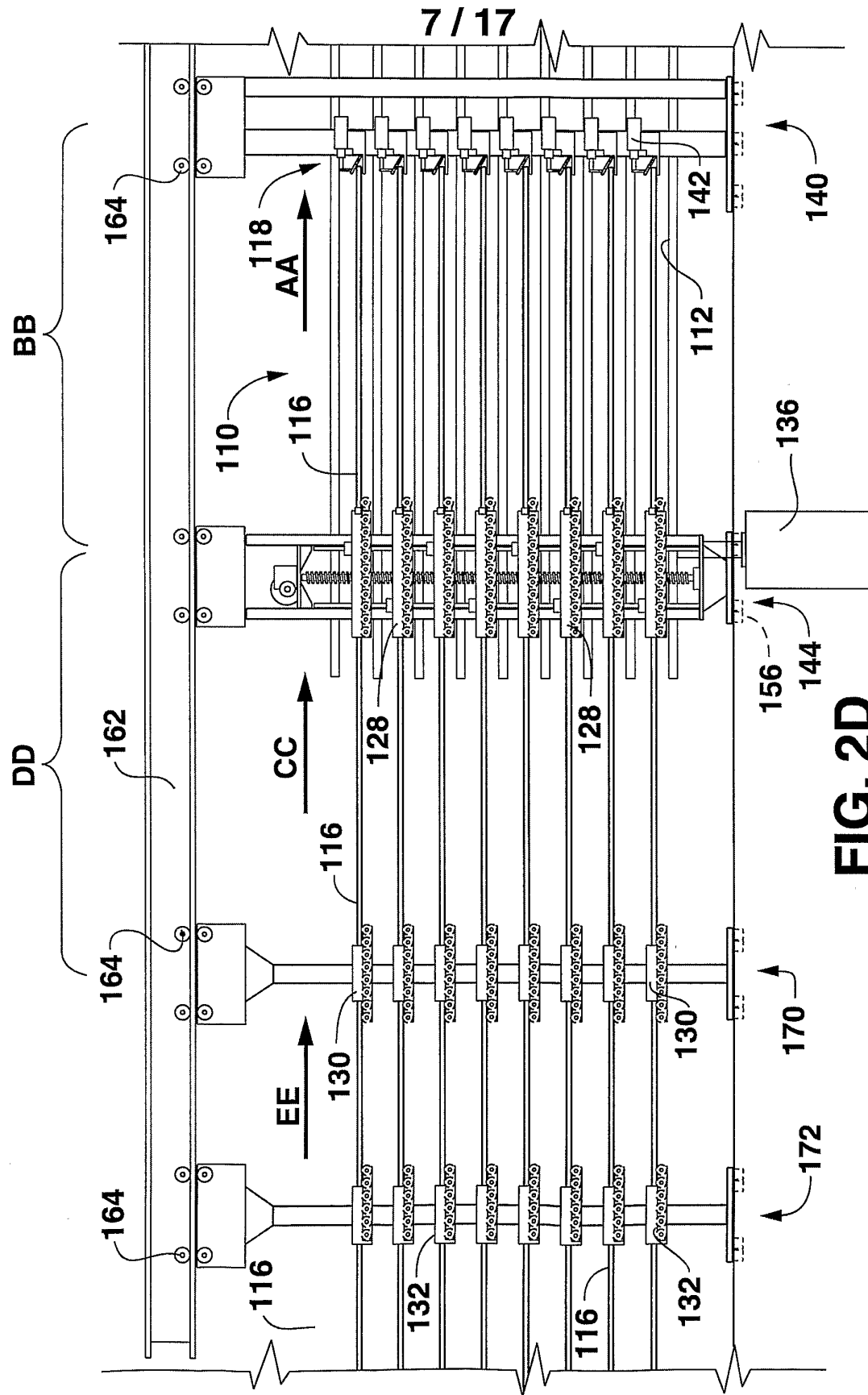

FIG. 2D

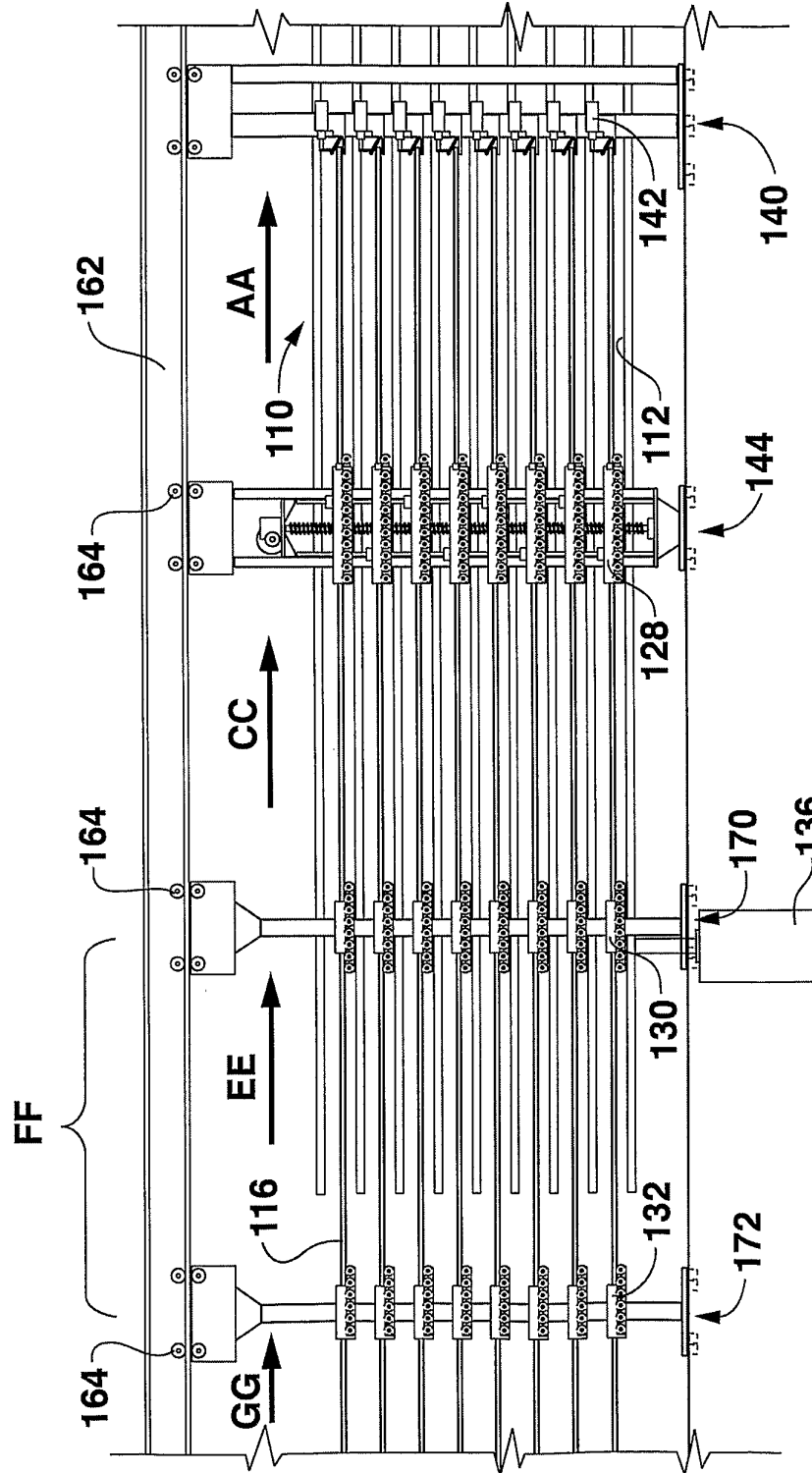

FIG. 2E

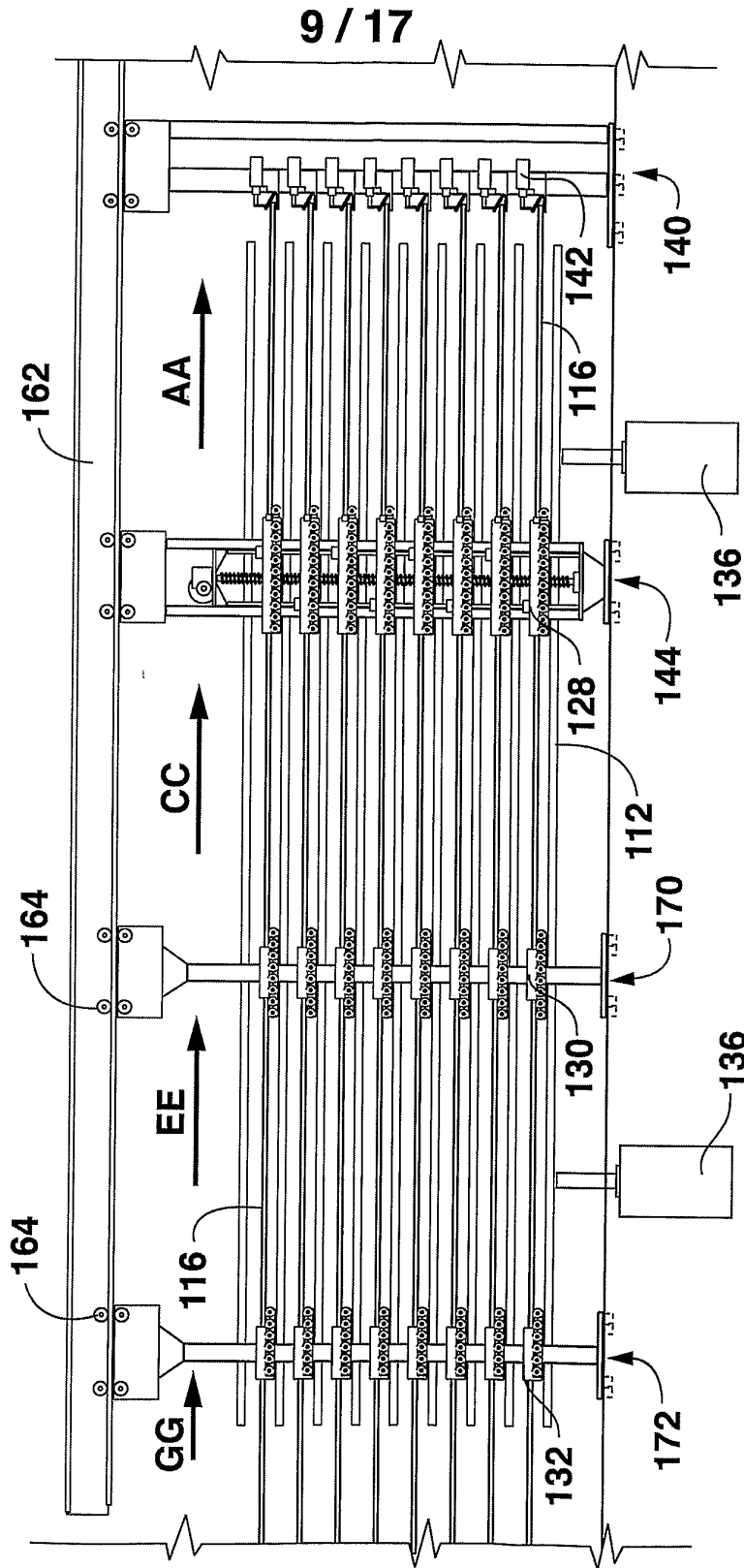

FIG. 2F

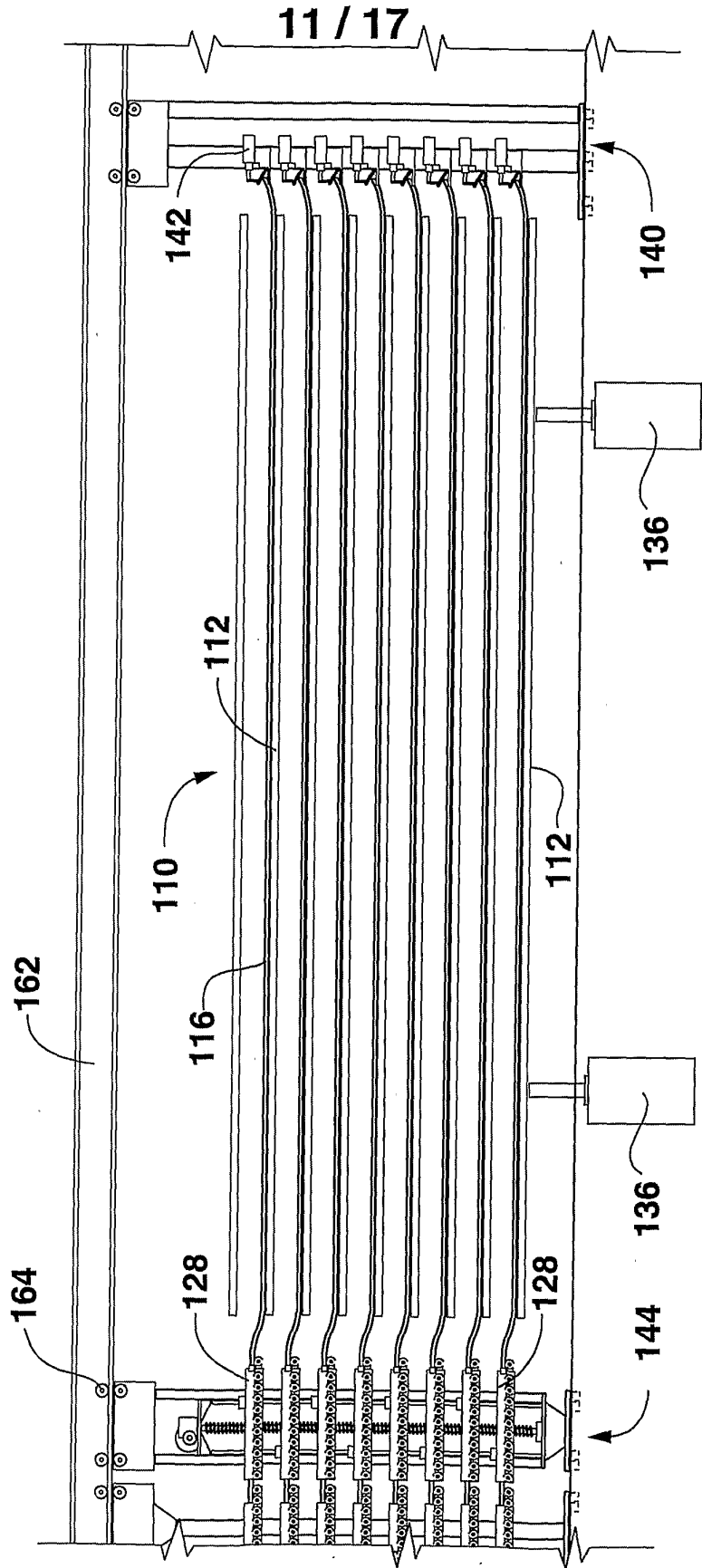

FIG. 2H

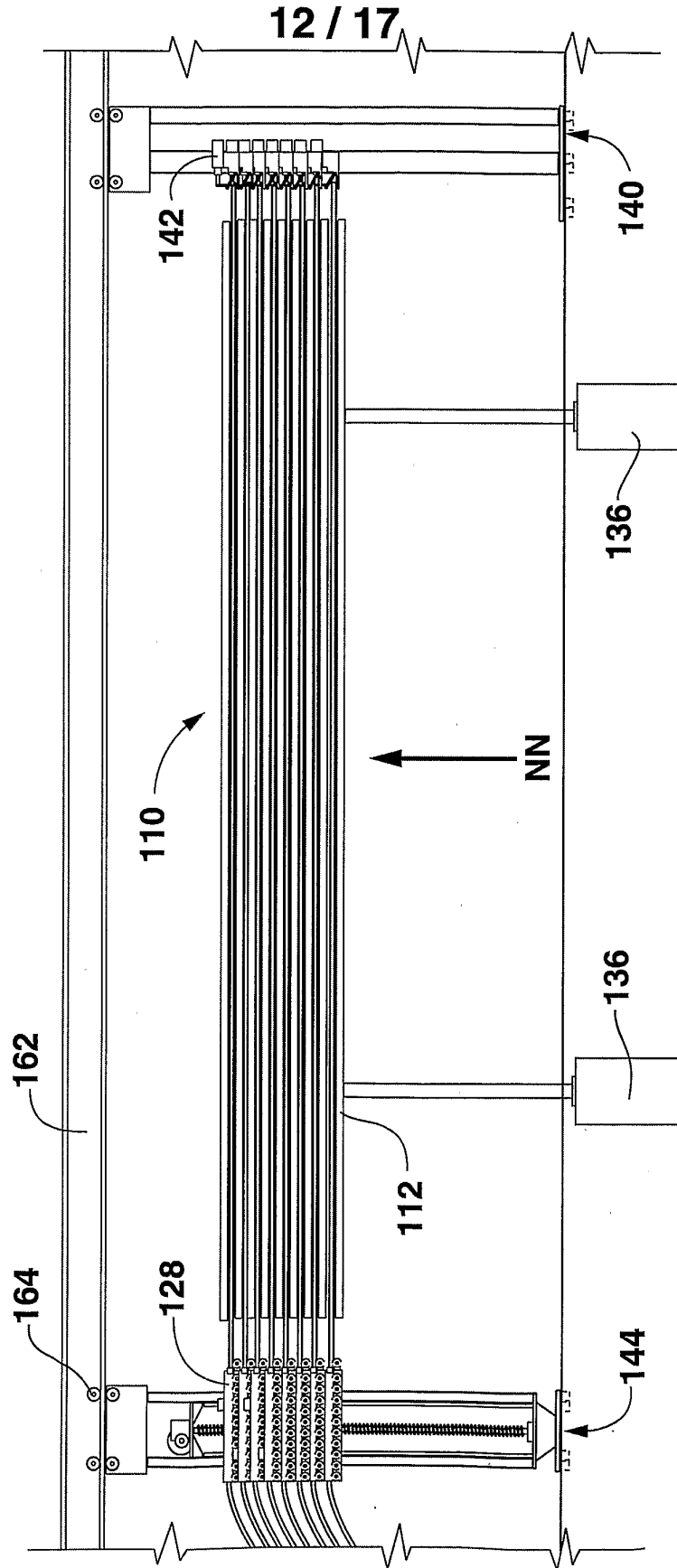

FIG. 21

13 / 17

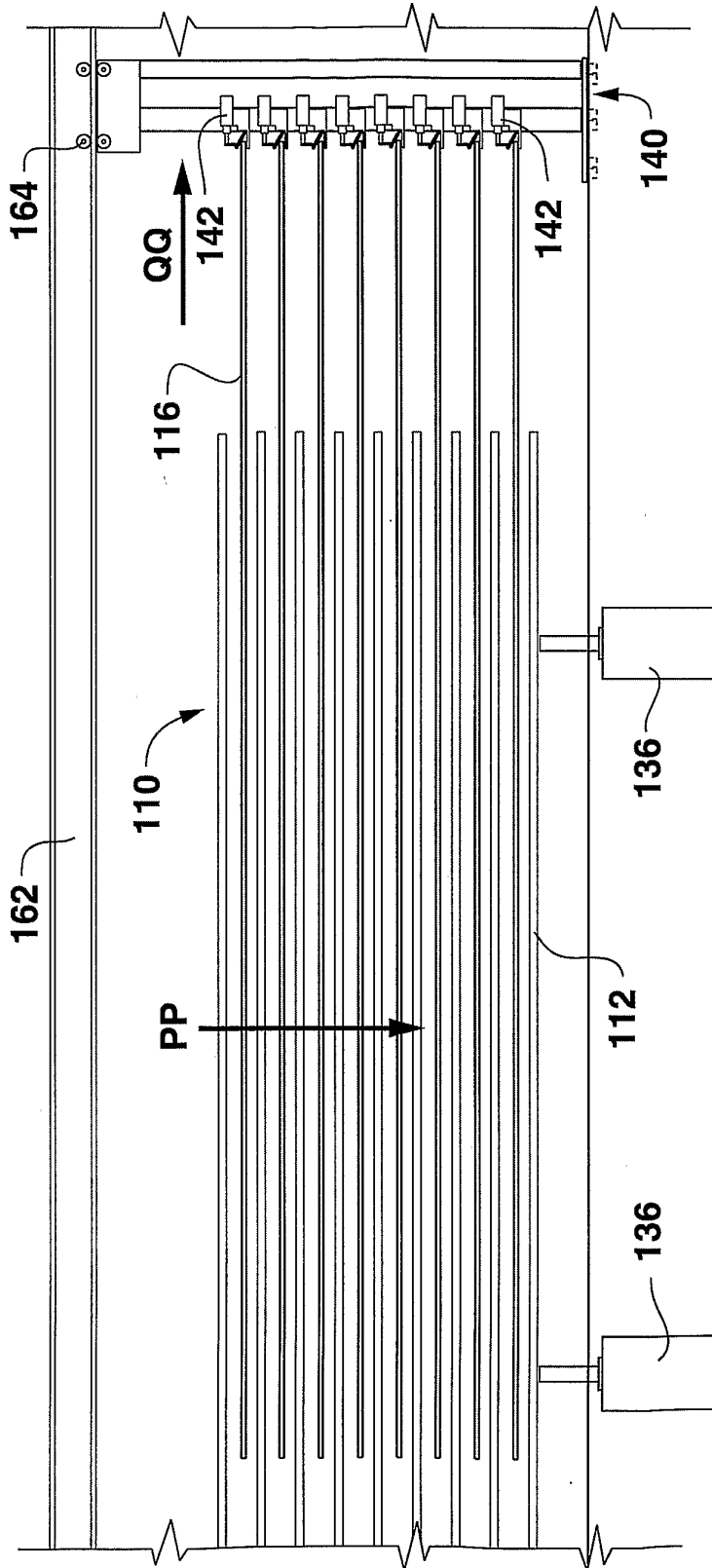
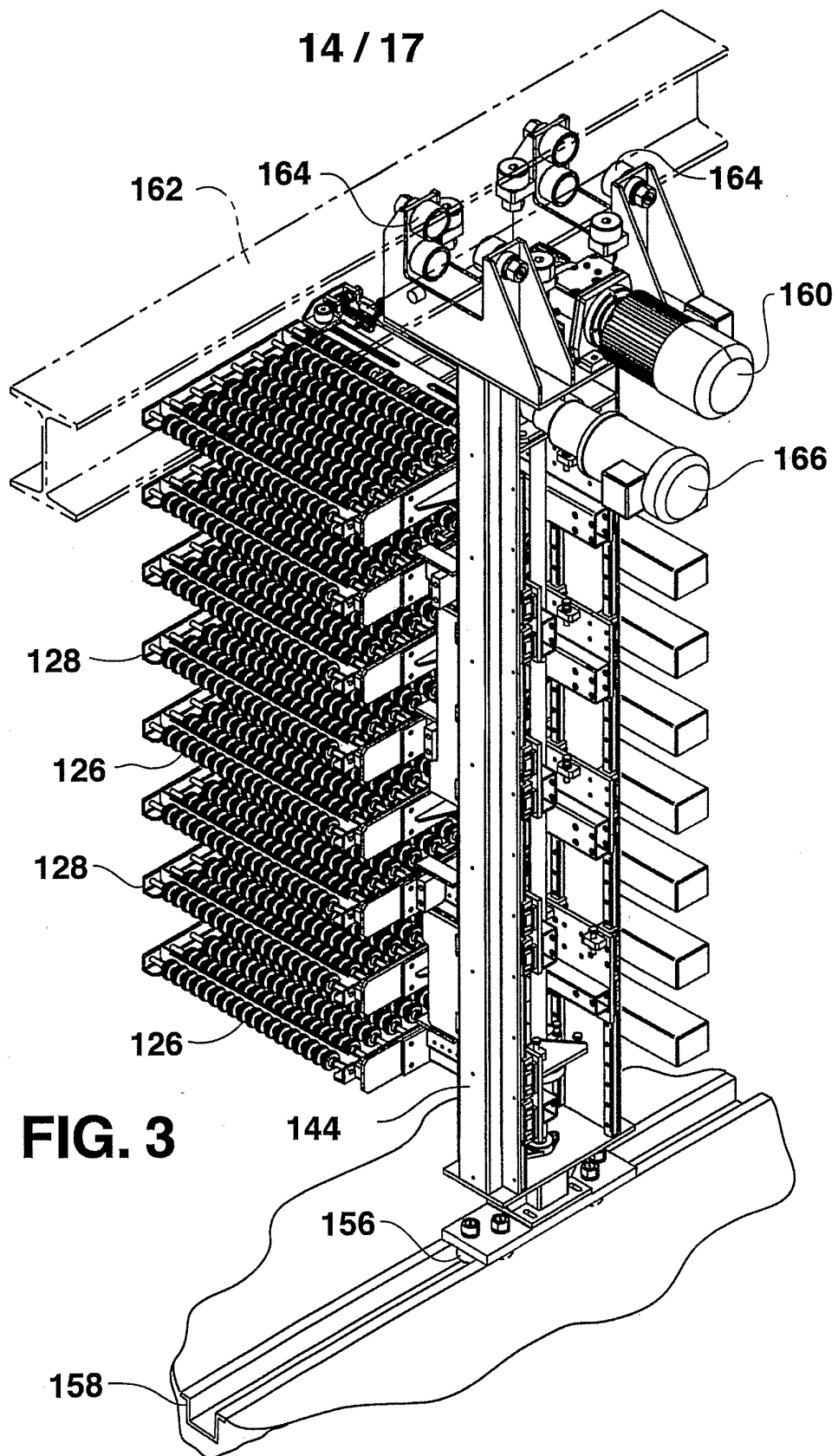

FIG. 2J



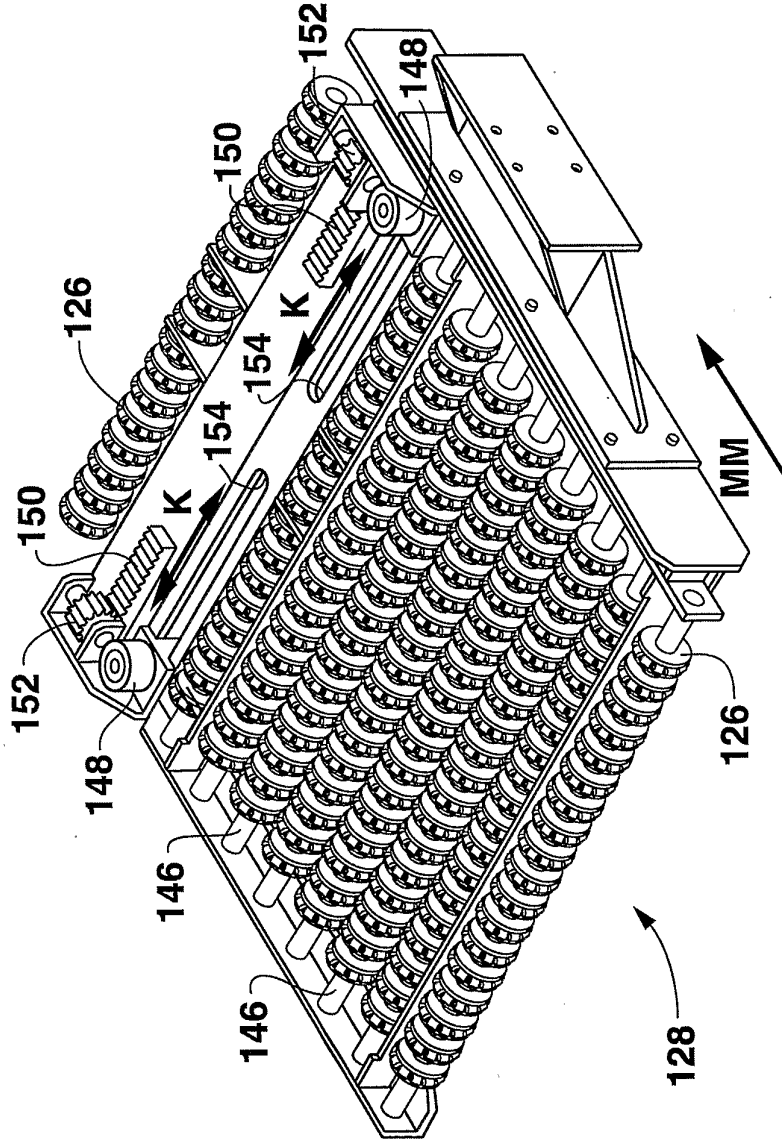

FIG. 4A

16 / 17

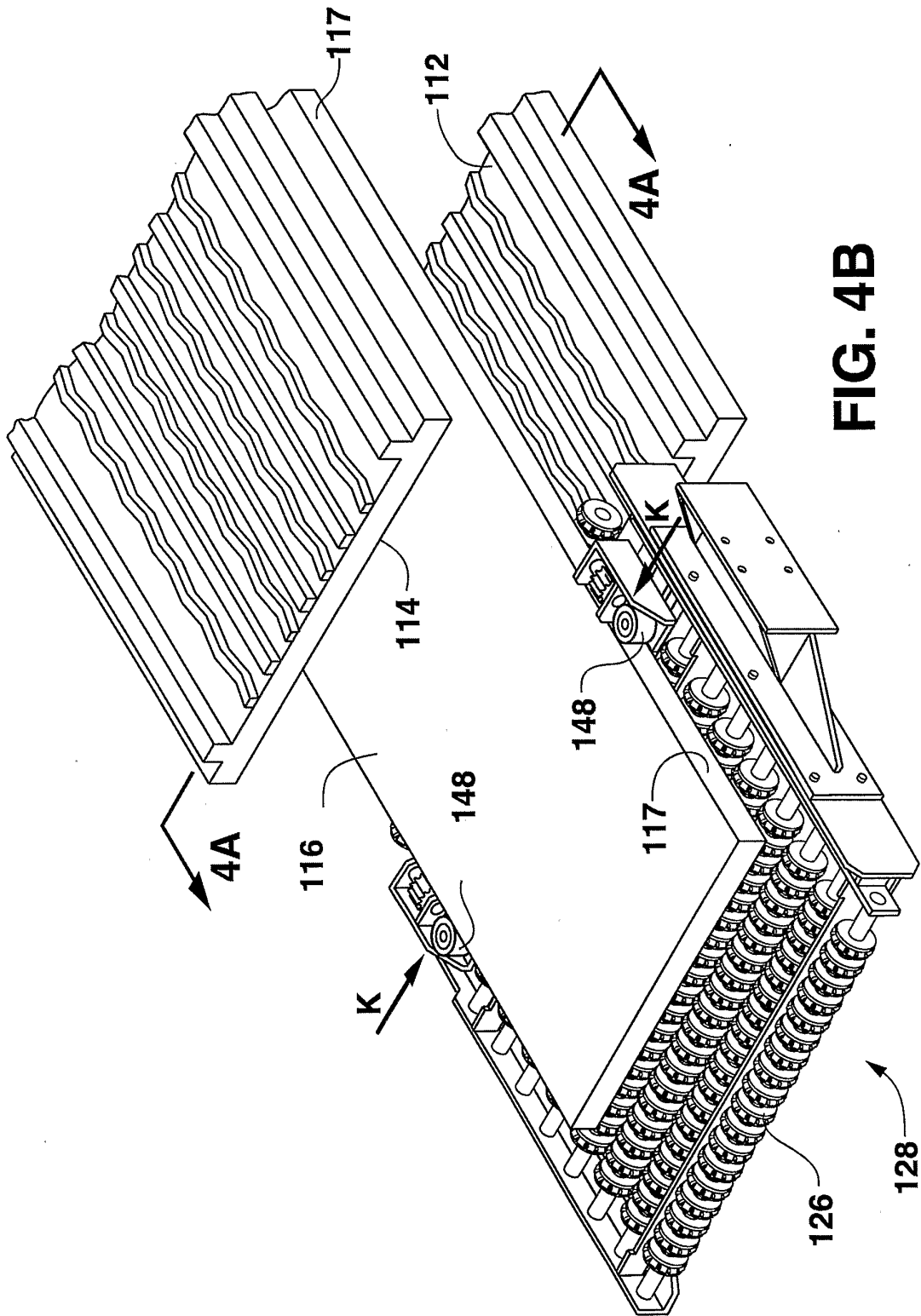

FIG. 4B

17 / 17

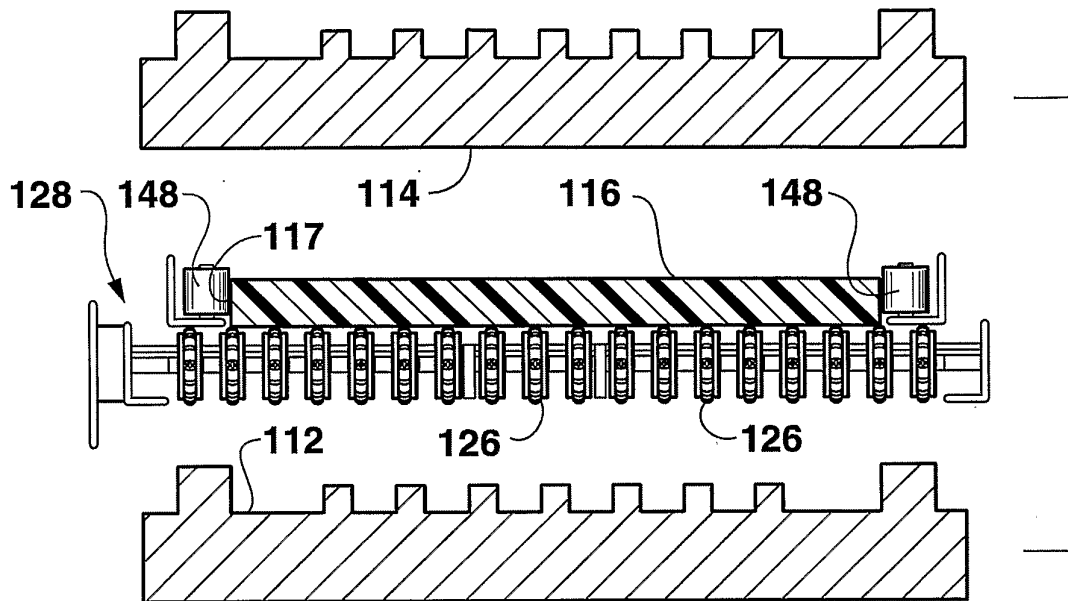

FIG. 5A

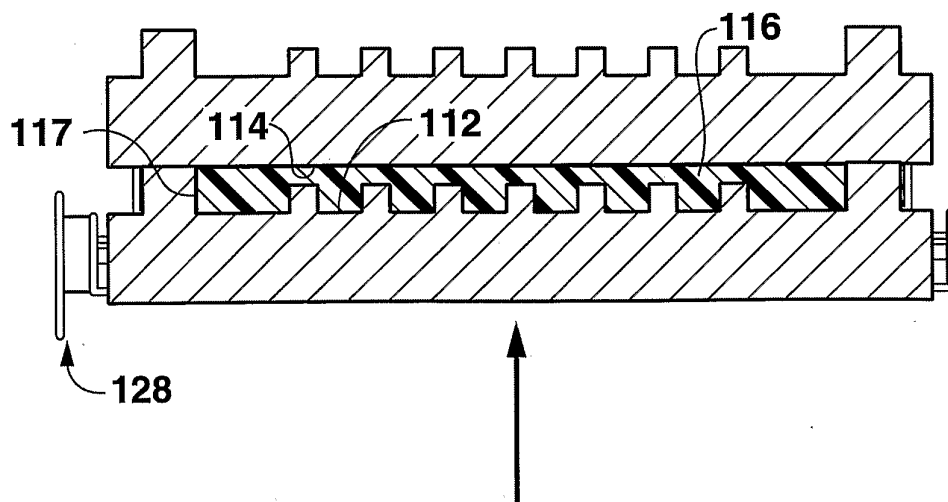

FIG. 5B