

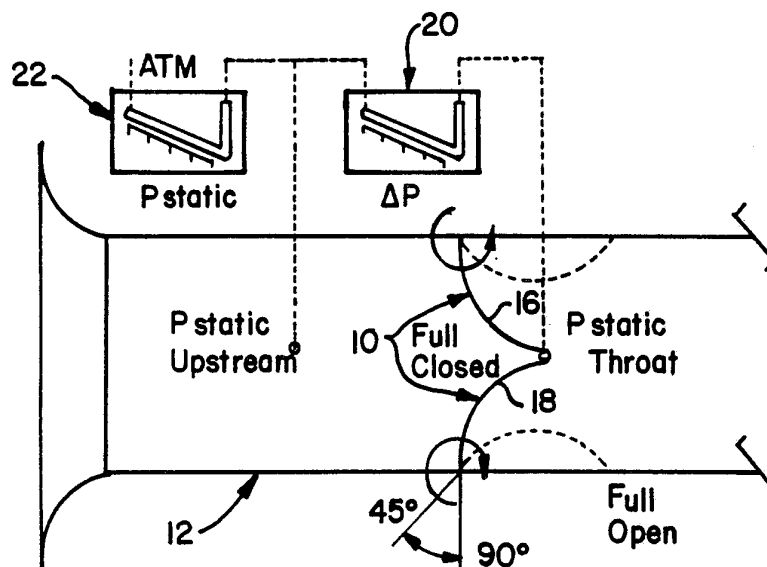

INTERNATIONAL APPLICATION PUBLISHED UNDER THE PATENT COOPERATION TREATY (PCT)

<p>(51) International Patent Classification ⁵ : G01F 1/40</p>	<p>A1</p>	<p>(11) International Publication Number: WO 93/15380 (43) International Publication Date: 5 August 1993 (05.08.93)</p>
<p>(21) International Application Number: PCT/US92/08375 (22) International Filing Date: 2 October 1992 (02.10.92) (30) Priority data: 825,347 24 January 1992 (24.01.92) US (71) Applicant: COMBUSTION ENGINEERING, INC. [US/US]; 1000 Prospect Hill Road, Windsor, CT 06095 (US). (72) Inventors: KOZLAK, Martin, John ; 8 Valley View Circle Drive, Enfield, CT 06082 (US). ANDERSON, David, Kenneth ; 25 Mapleshade Avenue, East Longmeadow, MA 01028 (US).</p>		<p>(74) Agents: FOURNIER, Arthur, E., Jr. et al.; ABB Business Services Inc., 1000 Prospect Hill Road, Windsor, CT 06095 (US). (81) Designated States: JP, KR, European patent (AT, BE, CH, DE, DK, ES, FR, GB, GR, IE, IT, LU, MC, NL, SE). Published <i>With international search report.</i></p>

(54) Title: NOZZLE DAMPER ASSEMBLY



(57) Abstract

A nozzle damper assembly (10) for installation in a duct (12) operative for measuring and controlling the flow of a gaseous medium through the duct (12). The subject nozzle damper assembly (10) includes enclosure means (24) cooperatively associated with the duct (12), shaft means (26) suitably supported from the sidewalls (32, 34, 36, 38) of the enclosure means (24), damper blade means (16, 18) rotatably mounted on the shaft means (26) for movement within the enclosure means (24), damper blade operating means (28) operative for purposes of effecting the movement of the damper blade means (16, 18) within the enclosure means (24), and flow measurement means (20, 22) supported upstream and downstream of the damper blade means (16, 18) and operative to measure the flow of the gaseous medium through the nozzle damper assembly (10) such that control may be exercised over the flow of the gaseous medium through the duct (12) based on such measurements.

FOR THE PURPOSES OF INFORMATION ONLY

Codes used to identify States party to the PCT on the front pages of pamphlets publishing international applications under the PCT.

AT	Austria	FR	France	MR	Mauritania
AU	Australia	GA	Gabon	MW	Malawi
BB	Barbados	GB	United Kingdom	NL	Netherlands
BE	Belgium	GN	Guinea	NO	Norway
BF	Burkina Faso	GR	Greece	NZ	New Zealand
BG	Bulgaria	HU	Hungary	PL	Poland
BJ	Benin	IE	Ireland	PT	Portugal
BR	Brazil	IT	Italy	RO	Romania
CA	Canada	JP	Japan	RU	Russian Federation
CF	Central African Republic	KP	Democratic People's Republic of Korea	SD	Sudan
CG	Congo	KR	Republic of Korea	SE	Sweden
CH	Switzerland	KZ	Kazakhstan	SK	Slovak Republic
CI	Côte d'Ivoire	LJ	Liechtenstein	SN	Senegal
CM	Cameroon	LK	Sri Lanka	SU	Soviet Union
CS	Czechoslovakia	LU	Luxembourg	TD	Chad
CZ	Czech Republic	MC	Monaco	TG	Togo
DE	Germany	MG	Madagascar	UA	Ukraine
DK	Denmark	ML	Mali	US	United States of America
ES	Spain	MN	Mongolia	VN	Viet Nam
FI	Finland				

NOZZLE DAMPER ASSEMBLY

BACKGROUND OF THE INVENTION

This invention relates to devices for controlling the
5 flow of a medium through a conduit, and more specifically, to a
nozzle damper assembly for controlling as well as measuring the flow
of a gaseous medium through a duct.

It has long been known in the prior art to provide
10 devices operable for controlling the flow of a medium through a
conduit. More specifically, the prior art is replete with examples
of various types of devices that have been used heretofore to effect
control over the flow of a medium through a conduit. In this regard,
in many instances discernible differences of a structural nature can
be found to exist between individual ones of the aforesaid devices.
15 The existence of such differences is, in turn, attributable for the
most part to the diverse functional requirements that are associated
with the individual applications in which such devices are designed
to be employed. For instance, in the selection of the particular
type of device that is to be utilized for a specific application, one
20 of the principal factors to which consideration must be given is that
of the nature of the medium, the flow of which is to be controlled by
the device. Gaseous mediums are one such type of medium wherein
there is a need to control the flow thereof through a conduit.
Furthermore, the air flow to a pulverizer as well as the air flow to
25 other forms of equipment that are utilized in power generation
systems are representative of applications in which there is a need
to effect control over the flow of a gaseous medium as well as a need
in some instances to effect, in addition, measurements of the flow of
the gaseous medium.

- 2 -

By way of exemplification and not limitation, one particular type of flow control device heretofore known in the prior art forms the subject matter of U. S. Patent No. 3,749,115. As set forth in U. S. Patent No. 3,749,115, industrial plants commonly
5 employ ducts for conducting various types of gaseous fluids. Moreover, where it is desired to regulate or to terminate the flow of such fluids through a duct, dampers are employed. In large ducts of extended lateral dimensions a plurality of aligned, mutually cooperating dampers are employed to close the duct passage. A
10 totally effective seal of the duct passage is not possible in actual practice solely by means of a cooperation between adjacent dampers due to the difficulty in achieving a fluid tight metal-to-metal seal. This is caused principally by the fact that warpage of the members normally occurs when the dampers are disposed in a high temperature
15 environment or particulate matter is deposited on the mating surfaces of adjacent members when they are disposed in an unclean atmosphere thereby preventing the mating surfaces from seating properly. A combination of both conditions prevails in some application such as, for instance, the combustion gas duct of vapor generators.

20 Therefore, in accordance with the teachings of U. S. Patent No. 3,749,115, a flow damper apparatus of relatively inexpensive construction is provided that is effective to positively prevent the flow of controlled gaseous fluid in a duct passage. To this end, the dampers are formed as hollow bodies and are connected
25 to a source of sealing fluid. In addition, oppositely spaced seal plates disposed along the edges of the damper bodies form spaces between adjacent dampers into which sealing fluid is directed thereby forming a fluid seal between the upstream and downstream sides of the damper apparatus.

30 By way of exemplification and not limitation, another prior art type of flow control device forms the subject matter of U. S. Patent No. 3,854,500. More specifically, U. S. Patent No. 3,854,500 is directed to large fluid shut-off valves of the gate type. Gate valves, as set forth in U. S. Patent No. 3,854,500, are
35 widely used in the control of large fluid flows because of the desirable flow characteristics produced by their unimpeded flow-through construction. The typical gate valve consists merely of a

valve body with a through passage for the flow of liquid and a transverse track or seat which permits and guides the movement of a plate-like gate for flow blocking. A large number of problems are inherent, however, in the operation of such gate valves.

5 To this end, in accordance with the teachings of U. S. Patent No. 3,854,500 a gate valve is provided that is designed to overcome the cocking, warping, linear expansion friction due to high pressures, and fluid leakage problems experienced by the prior art. Furthermore, the nature of the construction of the gate valve of
10 U. S. Patent No. 3,854,500 is such that the driving or closing means is connected to the gate by a centrally located pivotal connection, thereby allowing closing and opening of the valve without blade cocking. Moreover, a multiparallel gate is proposed to reduce the size of the individual gates thereby reducing the large thermal warp
15 observed in one large gate. Gates of reduced size also reduce the overall linear temperature expansion observed in large gates, thus allowing smaller clearances and reduced gas leakage. To overcome the friction problem resulting from high pressures pressing on the gate valve, the nature of the construction of the gate valve of U. S.
20 Patent No. 3,854,500 is such that an air cushion support lifts the gate against the high pressure and allows low friction opening of the gate. This support consists of pressurized air which is admitted to a series of end-to-end grooves whose openings face upstream and face the edge portion of the downstream face of the gate. Pressurized air
25 is admitted to each groove by valves triggered by the movement of the gate. Finally, the gate sealing means consists of a plurality of longitudinal grooves arranged in the valve body facing upstream and parallel to the direction of movement of the gate. The gate blade's edges slide along and overlie the grooves creating close metal-to-
30 metal contact and a labyrinthian seal.

By way of exemplification and not limitation, yet another prior art type of flow control device forms the subject matter of U. S. Patent No. 3,889,552. More specifically, U. S. Patent No. 3,889,552 is directed to an actuating device for multiple dampers.
35 As set forth in U. S. Patent No. 3,889,552, it is known that during low load operation of large steam generators, vibration of the induced draft fan or gas recirculation fan is sometimes encountered.

In this regard, the inlets to these fans are controlled by a multitude of small coacting dampers extending across the width of the inlet ducts. Furthermore, it has been determined that one way of reducing fan vibration problems is to have a fine control over the damper positions during low load operation, and to allow flow through only selective dampers.

To this end, in accordance with the teachings of U. S. Patent No. 3,889,552 a single actuating device is provided which permits initial opening of one or more of a plurality of dampers, while the other dampers remain in their closed position. The actuating device further accomplishes full opening of all of the dampers simultaneously. The actuating device comprises a linkage arrangement having a dogleg link therein for accomplishing the above.

Yet still another prior art form, by way of exemplification and not limitation, of flow control device forms the subject matter of U. S. Patent No. 4,182,359. More specifically, U. S. Patent No. 4,182,359 is directed to a slide gate damper. As set forth in U. S. Patent No. 4,182,359 it has been known in the prior art that in large ducts gate valves are often used for closing the ducts from flow therethrough. Such gate valves are positioned on one side of the duct, and are moved transversely so they extend entirely across the span of the duct when in a closed position, with the leading edge seating in an end frame. Moreover, when the duct is conveying hot gases, the large span of the gate can warp, causing proper seating problems in the end frame. Also, when the gases are dust laden, the dust can become trapped in the end frame, preventing proper seating of the gate valve. Further, if there is a need for a concentric pipe, or other control obstruction in the large duct, it is presently impossible to position a gate valve at this location.

To this end, in accordance with the teachings of U. S. Patent No. 4,182,359 a double gate valve arrangement is provided with the gates being positioned diametrically opposite each other, so they close and seat in the middle of the duct. In addition, the leading edge of each gate is tapered back from the side edges so that they will properly seat even if they are slightly warped from the seat. Finally, an air seal is provided to prevent any leakage through the gate.

Although flow control devices constructed in accordance with the teachings of the four issued U. S. patents to which reference has been made heretofore have been demonstrated to be operative for the purpose for which they have been designed, there
5 has nevertheless been evidenced in the prior art a need for such flow control devices to be further improved. For example, desirably such flow control devices should possess the capability of being able to not only control but also of being able to simultaneously measure the flow of a gaseous medium through a duct. Moreover, there has been
10 evidenced in the prior art a need for a new and improved flow measuring and control device which would permit a wider range of flow rates to be handled than that which is possible with a fixed throat area device such as a venturi or flow nozzle. Namely, whereas prior art forms of flow control devices often times have been limited to a
15 turndown of 4 to 1, there has been evidenced in the prior art a need for a new and improved measuring and control device with which one would be able to achieve a much wider range of turndown ratios, e.g., on the order of up to 40 to 1. In addition, there has been evidenced in the prior art a need for a new and improved flow measuring and
20 control device with which one is capable of achieving a turndown ratio of up to 40 to 1 and wherein furthermore it is possible by varying the throat area thereof to maintain virtually a constant differential pressure throughout this entire turndown ratio of up to 40 to 1. Another characteristic which such a new and improved flow
25 measuring and control device desirably should possess is that it be relatively short in length so as to, therefore, facilitate its installation in a duct. It is to be noted in this regard that the ducts in which such a new and improved flow measuring and control device would be designed to be used commonly would be on the order of
30 five feet by five feet, six feet by six feet, etc., depending upon the nature of the specific application in which the new and improved flow measuring and control device is being employed. Yet another characteristic which such a new and improved flow measuring and control device desirably should possess is that it be relatively
35 simple in construction. To this end, such a new and improved flow measuring and control device should embody, to the extent possible, a modular form of construction so as to, therefore, facilitate the

manufacture, transport and installation thereof. Thus, by way of summarization a need has been evidenced in the prior art for such a new and improved flow measuring and control device that is suitable for use for purposes of effectuating the simultaneous measurement and
5 control of the flow of a gaseous medium such as air through a duct enroute to a pulverizer or to some other forms of equipment of the type that are commonly employed in power generation systems.

It is, therefore, an object of the present invention to provide a new and improved flow control device suitable for use for
10 purposes of effectuating control over the flow of a gaseous medium through a conduit.

It is a further object of the present invention to provide such a flow control device that possesses the capability of being able to not only control the flow but also the capability of
15 being able to simultaneously measure the flow of a gaseous medium through a conduit.

It is another object of the present invention to provide such a flow measuring and control device that is particularly suited for use in measuring and controlling the air flow entering exhaustertype pulverizers.
20

It is still another object of the present invention to provide such a flow measuring and control device that is particularly suited for use in measuring and controlling the air flow entering forms of equipment which are employed in power generation systems
25 other than exhaustertype pulverizers.

A further object of the present invention is to provide such a flow measuring and control device particularly suited for use in measuring and controlling the flow of a gaseous medium through a conduit which is characterized in that it is possible therewith to
30 handle a wider range of flow rates than that which is possible with a fixed throat area device such as a venturi or flow nozzle.

A still further object of the present invention is to provide such a flow measuring and control device particularly suited for use in measuring and controlling the flow of a gaseous medium
35 through a conduit which is characterized in that it possesses the capability of enabling a much wider range of turndown ratios to be attained therewith, e.g., up to 40 to 1, as contrasted to prior art

forms of flow control devices which oftentimes have been limited to turndown ratios of 4 to 1.

5 A still another object of the present invention is to provide such a flow measuring and control device particularly suited for use in measuring and controlling the flow of a gaseous medium through a conduit which is characterized in that it possesses the capability of being either manually operated or remotely operated.

10 Yet a further object of the present invention is to provide such a flow measuring and control device particularly suited for use in measuring and controlling a gaseous medium through a conduit which is characterized in that it is relatively short in length so as to, therefore, facilitate its installation in a conduit.

15 Yet another object of the present invention is to provide such a flow measuring and control device particularly suited for use in measuring and controlling the flow of a gaseous medium through a conduit which is characterized in that it embodies a modular form of construction thereby facilitating the manufacture, transport and installation thereof.

20 Yet still another object of the present invention is to provide such a flow measuring and control device particularly suited for use in measuring and controlling the flow of a gaseous medium through a conduit which is equally applicable for employment in new installations as well as in retrofit applications.

25 SUMMARY OF THE INVENTION

In accordance with the present invention there is provided a nozzle damper assembly which is particularly suited for use in power generation applications for purposes of effecting the measurement and control of the flow of air through a duct. The
30 subject nozzle damper assembly includes enclosure means, shaft means, damper blade means, damper blade operating means, and flow measurement means. The enclosure means is suitably designed so as to be capable of being cooperatively associated with the duct in which it is desired to employ the subject nozzle damper assembly. The
35 shaft means is suitably supported from opposing sidewalls of the enclosure means. The damper blade means is rotatably mounted on the shaft means for movement within the enclosure means. The damper

blade operating means is operatively connected to the damper blade means and is operative for purposes of effecting the movement of the damper blade means within the enclosure means. The flow measurement means is suitably supported upstream and downstream of the damper blade means such as to be operative to measure the air flow through the nozzle damper assembly whereby control may be exercised over the flow of air through the subject nozzle damper assembly and thereby through the duct based on such measurements.

10 BRIEF DESCRIPTION OF THE DRAWING

Figure 1 is a schematic illustration of a nozzle damper assembly constructed in accordance with the present invention shown installed in a duct;

Figure 2 is an isometric view of a nozzle damper assembly, with the flow measurement means thereof omitted in the interest of clarity of illustration, constructed in accordance with the present invention shown installed in a duct;

Figure 3 is a side elevational view in section of the damper means of one embodiment of a nozzle damper assembly constructed in accordance with the present invention;

Figure 4 is a side elevational view in section of the shaft means of the nozzle damper assembly of the embodiment of Figure 3 constructed in accordance with the present invention;

Figure 5 is a side elevational view of the enclosure means of a nozzle damper assembly constructed in accordance with the present invention;

Figure 6 is a side elevational view of the damper blade operating means of the nozzle damper assembly of the embodiment of Figure 3 constructed in accordance with the present invention;

Figure 7 is a side elevational view in section of the damper means of another embodiment of a nozzle damper assembly constructed in accordance with the present invention;

Figure 8 is a side elevational view in section of the shaft means of the nozzle damper assembly of the embodiment of Figure 7 constructed in accordance with the present invention;

Figure 9 is a side elevational view of the damper blade operating means of the nozzle damper assembly of the embodiment of Figure 7 constructed in accordance with the present invention;

Figure 10 is a cross-sectional view of a portion of the damper blade operating means of the nozzle damper assembly of the embodiment of Figure 7 constructed in accordance with the present invention taken substantially along the line 10-10 in Figure 9;

Figure 11 is a graphical depiction of one aspect of the performance of a nozzle damper assembly constructed in accordance with the present invention wherein pressure loss, i.e., percentage of differential pressure, is plotted against damper angle expressed in degrees; and

Figure 12 is a graphical depiction of another aspect of the performance of a nozzle damper assembly constructed in accordance with the present invention wherein mass flow rate expressed in kilograms per hour is plotted for various damper angles against differential pressure expressed in millimeters of H₂O.

DESCRIPTION OF A PREFERRED EMBODIMENT

Referring now to the drawing, and more particularly to Figure 1 thereof, there is depicted therein a nozzle damper assembly, generally designated by the reference numeral 10 constructed in accordance with the present invention and shown installed in a duct, generally designated by the reference numeral 12. The nozzle damper assembly 10 is particularly suited for use in effectuating simultaneously the measurement and control of the flow of a gaseous medium such as air through a duct, such as the duct 12 of Figure 1, enroute to a pulverizer (not shown) or to some other forms of equipment (not shown) of the type that are commonly employed in power generation applications.

The nozzle damper assembly 10, as will be described herein in considerably more detail subsequently, embodies a pair of opposed damper blades, denoted by the reference numerals 16 and 18, respectively, in Figure 1. Each of the damper blades 16 and 18 comprises a 90° arc with a radius equal to one-half of the height of the duct 12. As so constructed, the nozzle damper assembly 10 is limited in use to ducts having a rectangular configuration.

Continuing, the damper blades 16 and 18 are each hinged at their leading edge, in a manner to be more fully described herein subsequently, such that the center of the rotation of each of the damper blades 16 and 18 is at the wall of the duct 12. For purposes
5 of this discussion, the minimum and maximum angles of rotation of the damper blades 16 and 18 are taken to be the included angle formed by the wall of the duct 12 and the tangent line at the hinge point of the respective one of the damper blades 16 and 18. Thus, there is provided a means of determining the open area of the throat of the
10 nozzle damper assembly 10 through indication of the angle of rotation of the damper blades 16 and 18. To this end, based on the geometry of the nozzle damper assembly 10, a range from 45° at the full open condition to 90° at the full closed position is provided.

The basic rationale behind developing the nozzle damper
15 assembly 10, which forms the subject matter of the present patent application, resides in the fact that this type of flow measuring and control device enables a wider range of flow rates to be handled than with a fixed throat area device such as a venturi or flow nozzle. In this regard, there will arise occasions depending upon the operating
20 requirements of the particular application wherein the flow rate through a fixed area device will be reduced to levels that would be difficult to measure because of the low differential pressure that is present. On the other hand, it is possible with the nozzle damper
25 assembly 10 to close the damper blades 16 and 18 thereof to the point wherein the throat area of the nozzle damper assembly 10 nevertheless provides enough of a restriction that the resulting differential pressure is still large enough to be accurately measured by
30 conventional pressure sensing equipment such as of the type, which is denoted generally by the reference numerals 20 and 22 in Figure 1 of the drawing.

Before proceeding with a discussion of the effects of
damper blade stroke on the quantity of flow through the nozzle damper
assembly 10 of Figure 1, a discussion will first be had herein of the
basis for the measurement of differential pressure that has been
35 referred to hereinbefore. By doing so, a better understanding, it is believed, will be had of the variability of the throat area as well as of the relationship thereof to both the angle of the damper blades

- 11 -

16 and 18 and the measurement of flow through the nozzle damper assembly 10.

It is thought that the easiest way to approach the measurement of flow with a device such as the nozzle damper assembly 10 of Figure 1, which is capable of producing a differential pressure, is to begin with the concept of Continuity and Bernoulli's Equation. To this end, if one assumes that the air flow is incompressible and that there is no storage of the air flow between the upstream and downstream measurement points, then the air that goes into the nozzle damper assembly 10 must come out in the equivalent amount. This is expressed mathematically as:

$$P_1 A_1 V_1 = P_2 A_2 V_2$$

Further, Bernoulli's Equation indicates that the energy along a streamline remains constant for an incompressible, nonviscous fluid. This is written as:

$$P_s/p + V^2/2g_c = \text{constant}$$

Continuing, if ideal conditions and a constant air density are assumed, then the energy content of the flow exiting the nozzle damper assembly 10 of Figure 1 is going to be equal to that of the flow entering the nozzle damper assembly 10. This ideal flow situation may be written as:

$$P_{s1}/p + V_1^2/2g_c = P_{s2}/p + V_2^2/2g_c$$

Moreover, given that the static pressure P_s can be measured at the entrance to the nozzle damper assembly 10 where the area of the duct 12 is A_1 as well as at the throat of the nozzle damper assembly 10 where the area is A_2 , then the difference of the two static pressures can be written as:

$$\Delta P_s = pV_2^2/2g_c - pV_1^2/2g_c \quad (\text{lb/ft}^2)$$

Given a constant density, one can, based on the concept of Continuity, relate the throat velocity to upstream velocity as:

$$V_1 = V_2 (A_2/A_1) \quad (\text{ft/sec})$$

5

Further, by substituting for V_1 in the previous equation and by rearranging, there is obtained the following:

$$V_2 = \{[(2g_c/p)(\Delta P_s)]/[1-(A_2/A_1)^2]\}^{1/2} \quad (\text{ft/sec})$$

10

Additionally, it is known from the concept of Continuity that the flow rate through the duct 12 is equal to the flow rate through the nozzle damper assembly 10 so that the mass flow rate can be expressed as:

15

$$M = \rho A_2 V_2 \quad (\text{lb/sec})$$

Moreover, if one defines the area ratio as the throat area divided by the upstream area of the duct 12, i.e., as A_2/A_1 , then one may define the square root of this quantity as the Beta Ratio, B. Therefore,

20

$$A_2 = A_1 (A_2/A_1) = A_1 (B^2) \quad (\text{ft}^2)$$

Thus, by substituting for A_2 and V_2 , the equation for the mass flow rate through the nozzle damper assembly 10 becomes:

25

$$M = \rho A_1 (B^2) / [(2g_c/p)(\Delta P_s)/(1-B^4)]^{1/2} \quad (\text{lb/sec})$$

This last equation for M does not take into account any deviations from the ideal flow situation. These non-idealities are taken into account in the following equation for mass flow and are briefly defined below. However, since a discussion of these non-idealities is available in any text on flow measurement, no further discussion thereof will be had herein. Suffice it to say that the resulting equation for mass flow rate is:

35

- 14 -

3. Given that the height of the duct 12 is equal to $2R$ and that the throat is the height of the duct 12 minus the combined intrusion of the damper blades 16 and 18 at a given damper blade shaft angle θ , then the throat height is:

5

$$h = 2R(\cos\theta).$$

4. The ratio of the area of the throat (A_T) to the area of the duct 12 (A_D) is:

10

$$A_T/A_D = hW/HW = 2R(\cos\theta)/2R = \cos\theta$$

where W is the width of the duct 12 (and that of the damper blades 16 and 18).

15

5. The Beta Ratio is defined as the square root of the area ratio A_T/A_D which leads to the relationship:

$$B = \sqrt{\cos\theta}$$

20

Therefore, substituting $\cos\theta$ for B^2 and utilizing trigonometric identities yields the following equation for nozzle damper flow rate:

$$M = K(A_D/\tan\theta)(C_d)(Y)(F_a)\{h(P_s + P_B)/T\}^{1/2} \\ \text{(lb/min)}$$

25

It should thus be readily apparent from the preceding discussion that the ability to reduce the open area of the throat of the nozzle damper assembly 10 of Figure 1 permits a reduction in the mass flow rate while still maintaining a signal level that can be accurately read. This means that the differential pressure which is generated is controlled by the available open area of the nozzle throat as well as the actual flow rate. Furthermore, by relating the change in throat area to a change in the position of the damper blade shaft, the position of the damper blades 16 and 18 enters into the mass flow rate equation as B and becomes as much a variable as the differential pressure. As such, a much wider range of control is

35

achieved than was previously possible with a fixed throat area design.

This increased turndown capability of the nozzle damper assembly 10 of Figure 1 can be illustrated as follows:

- 5 1. Assume that C_d , Y , F_a , h , P_s , P_B and T are constants.
2. Based on 1. above, $\Delta M=f(B)$ where B can be defined as $\sqrt{\cos\theta}$, and θ is the rotational angle of the damper blades 16 and 18 for the range $45^\circ \leq \theta \leq 90^\circ$.
- 10 3. If the mass flow rate M is changed by reducing the throat open area of the damper blades 16 and 18 then:

$$M_1/M_2 = [(A_D^2/A_{T1}^2) - 1] / [(A_D^2/A_{T2}^2) - 1].$$

- 15 4. By definition, the area ratio A_T/A_D equals B^2 which in turn equals $\cos \theta$. Thus, through substitution:

$$M_1/M_2 = [(1 - \cos^2\theta_1) / \cos^2\theta_1] / [(1 - \cos^2\theta_2) / \cos^2\theta_2].$$

- 20 5. By using the identities $\sin^2\theta = 1 - \cos^2\theta$ and $\sin\theta/\cos\theta = \tan \theta$ and then substituting:

$$M_1/M_2 = [\tan^2\theta_1] / [\tan^2\theta_2].$$

- 25 6. At the full open condition of the damper blades 16 and 18, θ_1 is equal to 45° and $\tan \theta_1$ equals 1. As such, the mass flow rate as a function of the throat area is defined by the reciprocal of the square of the tangent of the damper shaft rotational angle:

$$30 \quad M_1/M_2 = 1/\tan^2\theta_2$$

Thus, it should be readily apparent from the preceding that if the turndown ratio is 10, then the damper blade rotational angle will be about 85° . This ability to obtain a 10 to 1 turndown on the mass flow rate at a constant pressure is augmented by the nominal range of the pressure sensing equipment, which is

schematically depicted at 20 and 22 in Figure 1 of the drawing. Namely, a typical pressure sensor can be set up to provide a 4 to 1 turndown on the mass flow rate for a fixed measurement device geometry. Therefore, combining the two ranges, i.e., that created by
5 the throat area adjustment and that of the pressure sensor, yields a total turndown capability on the mass flow rate of 40 to 1.

Reference will now be had particularly to Figures 2-6 of the drawing for purposes of describing the nature of the construction and the mode of operation of one embodiment of nozzle damper assembly
10 10. It should be noted here that the embodiment of nozzle damper assembly 10, which is depicted in Figures 2-6 of the drawing, is characterized by the fact that the positioning of the damper blades 16 and 18 thereof is done manually as contrasted to the embodiment of nozzle damper assembly 10, which is depicted in Figures 7-10 of the
15 drawing, wherein the positioning of the damper blades 16 and 18 thereof is accomplished by pneumatic means. Note is further taken here of the fact that as has been mentioned previously herein the nozzle damper assembly 10 is particularly suited for inclusion in a duct such as the duct depicted at 12 in Figure 1 of the drawing.

20 Continuing, in accordance with the present invention the embodiment of nozzle blade assembly 10, which is depicted in Figures 2-6 of the drawing, comprises enclosure means denoted generally in Figure 2 by the reference numeral 24, shaft means denoted generally in Figure 4 by the reference numeral 26, damper blade means including
25 the damper blades 16 and 18 to which reference has been had herein previously in the course of the discussion of Figure 1 of the drawing, damper blade operating means denoted generally in Figure 2 by the reference numeral 28, and flow measurement means including the pressure sensing equipment 20 and 22 to which reference has been had
30 herein previously in the course of the discussion of Figure 1 of the drawing. In the interest of maintaining clarity of illustration in the drawing, the aforementioned flow measurement means including the pressure sensing equipment 20 and 22 thereof has been omitted from each of Figures 2-6 of the drawing.

35 The enclosure means 24, as best understood with reference to Figures 2-5 of the drawing, consists of a damper body 30 that is suitably dimensioned and configured so as to conform to the external

- 17 -

dimensions and configuration of the duct 12 with which the nozzle damper assembly 10 of the present invention is intended to be employed. To this end, the damper body 30 consists of four sidewalls 32, 34, 36 and 38, which are suitably joined to one another by means of any conventional form of joining means (not shown) suitable for use for this purpose such as, for example, by being welded to one another. As so joined, the sidewalls 32 and 36 extend parallel to one another and at right angles to each of the sidewalls 34 and 38. Furthermore, in accordance with the preferred embodiment of the invention each of the sidewalls 32, 34, 36 and 38 is preferably provided with flange portions 32a, 34a, 36a and 38a, respectively. These flange portions 32a, 34a, 36a and 38a are intended to be utilized for purposes of securing the nozzle damper assembly 10 in place relative to the duct 12 through the use of a multiplicity of conventional fasteners (not shown). These fasteners (not shown) are intended to be inserted through the openings 32b, 34b, 36b and 38b, which are provided for this purpose in the flanges 32a, 34a, 36a and 38a, respectively, as will be best understood with reference to Figure 5 of the drawing. Although in accordance with the illustration thereof in Figures 2-6 of the drawing, the nozzle damper assembly 10 is designed to be secured in place relative to the duct 12 through the use of a multiplicity of conventional fasteners (not shown), it is to be understood that other means might be utilized for this purpose without departing from the essence of the present invention.

A description will next be had herein of the shaft means 26. For this purpose reference will be had in particular to Figures 3 and 4 of the drawing. As best understood with reference to Figure 3, the shaft means 26 includes a pair of shaft members, which are denoted in Figure 3 by the reference numerals 40 and 42. The damper blades 16 and 18 to which reference has been had herein previously are mounted on the shaft members 40 and 42, respectively, in a manner that will be described more fully hereinafter. The shaft members 40 and 42 themselves are suitably supported in mounted relation on the sidewalls 34 and 38 of the damper body 30 as best seen with reference to Figure 4 of the drawing.

Inasmuch as each of the shaft members 40 and 42 is supported in mounted relation on the sidewalls, 34 and 38 of the damper body 30 in the identical manner, it is deemed adequate for purposes of acquiring an understanding of the present invention that there be set forth herein only a description of the manner in which the shaft member 42 is supported in mounted relation on the sidewalls 34 and 38. To this end, as best understood with reference to Figure 4 of the drawing the shaft member 42 is suitably supported within a bearing and stuffing box assembly generally denoted by the reference numeral 44 in Figure 4. More specifically, the shaft member 42 extends through the bearing and stuffing box assembly 44 and has one end thereof denoted by the reference numeral 42a in Figure 4, which projects through an opening 46 formed for this purpose in the sidewall 38 of the damper body 30. The other end, which is denoted by the reference numeral 42b, of the shaft member 42 passes through a U-shaped member 48 and then through a packing gland 50. In accord with the best made embodiment of the invention, fiber glass rope denoted by the reference numeral 52 is preferably interposed between the U-shaped member 48 and the packing gland 50 in surrounding relation to the end 42b of the shaft member 42. With further reference to Figure 4 of the drawing, the packing gland 50 as depicted therein is suitably secured to the bearing and stuffing box assembly 44 preferably by means of a plurality of conventional fasteners denoted by the reference numeral 54 which after passing through suitable openings (not shown) provided for this purpose in the packing gland 50 and corresponding openings (not shown) formed in a plurality of outwardly projecting lugs 44a with which the bearing and stuffing box assembly 44 is suitably provided for this purpose are threadedly engaged in conventional nuts seen at 56 in Figure 4 of the drawing. Finally, by way of reiteration it is to be understood that the shaft member 40, although it has not been so described herein, is supported in mounted relation on the sidewalls 34 and 38 of the damper body 30 in the same manner that the shaft member 42 as has been described hereinbefore is supported in mounted relation on the sidewalls 34 and 38 of the damper body 30.

Next, a discussion will be had herein of the manner in which the damper blades 16 and 18 of the damper blade means of the

nozzle damper assembly 10 of the present invention are suitably mounted in supported relation on the shaft members 40 and 42, respectively. Reference will be had for this purpose in particular to Figures 3 and 4 of the drawing. Thus, as best understood with
5 reference to Figure 3 of the drawing one end thereof, denoted by the reference numerals 16a and 18a, respectively, of each of the damper blades 16 and 18 terminates in a coiled portion suitably dimensioned so as to be capable at one end thereof of receiving therewithin one end, denoted by the reference numeral 40a, of the shaft member 40 in
10 the case of the shaft member 40 and the end 42a of the shaft member 42 in the case of the shaft member 42. Also, a bearing member denoted by the reference numeral 58 preferably is interposed between the end 40a of the shaft member 40 and the coiled portion 16a of the damper blade 16. Likewise, a bearing member denoted by the reference
15 numeral 60 preferably is interposed between the end 42a of the shaft member 42 and the coiled portion 18a of the damper blade 18. In accord with the illustrated embodiment of the invention a pair of roll pins denoted by the reference numeral 62 suitably spaced one from another are employed for purposes of retaining the bearing
20 member 58 and one end of the coiled portion 16a of the damper blade 16 in secured relation to the end 40a of the shaft member 40, and for purposes of retaining the bearing member 60 and one end of the coiled portion 18a of the damper blade 18 in secured relation relative to the end 42a of the shaft member 42. Note is made here of the fact
25 that only one roll pin 62 is visible in Figure 3 of the drawing associated with the coiled portion 16a of the damper blade 16 and the coiled portion 18a of the damper blade 18, respectively.

The other ends of the coiled portions 16a and 18a of the damper blades 16 and 18, respectively, are each mounted in supported
30 relation on the sidewall 34 of the damper body 30. Inasmuch as the other ends of the coiled portions 16a and 18a of the damper blades 16 and 18, respectively, are each mounted in supported relation on the sidewall 34 of the damper body 30 in an identical manner, it is deemed adequate for purposes of acquiring an understanding of the
35 present invention that there be set forth herein only a description of the manner in which the other end of the coiled portion 18a of the damper blade 18 is mounted in supported relation on the sidewall 34

of the damper body 30. To this end, as best seen with reference to Figure 4 of the drawing, the other end of the coiled portion 18a of the damper blade 18 in accordance with the illustrated embodiment of the invention is mounted in supported relation on the sidewall 34 of the damper body 30 by means of a pivot pin set generally designated by the reference numeral 64. The pivot pin set 64 as depicted in Figure 4 of the drawing consists of a housing denoted by the reference numeral 66 that is secured to the outer surface of the sidewall 34 in juxtaposed relation to an opening (not shown) that is suitably provided for a purpose yet to be described. The housing 66 may be secured to the sidewall 34 through the use of any conventional form of securing means suitable for use for such a purpose such as by the housing being welded to the sidewall 34. Cooperatively associated with the housing 66 is a pin denoted by the reference numeral 68 which as seen with reference to Figure 4 of the drawing is designed to pass through the aforescribed opening (not shown) in the sidewall 34. The pin 68 is suitably received at one end in a member 70 that is secured within the other end of the coiled portion 18a of the damper blade 18 and is received in threaded engagement at the other end in the housing 66. Finally, by way of reiteration it is to be understood that the other end of the coiled portion 16a of the damper blade 16, although it has not been so described herein, is mounted in supported relation on the sidewall 34 of the damper body 30 in the same manner that the other end of the coiled portion 18a of the damper body 18 as has been described hereinbefore is mounted in supported relation on the sidewall 34 of the damper body 30.

Continuing with the description of the nature of the construction and the mode of operation of the nozzle damper assembly 10 of the present invention, attention will next be directed to the damper blade operating means of the nozzle damper assembly 10. As has been set forth herein previously, the nozzle damper assembly 10 may, without departing from the essence of the present invention, be provided with either of two different types of damper blade operating means. Namely, the nozzle damper assembly 10 may embody the manually operated type of damper blade operating means denoted generally by the reference numeral 28 that is utilized in the embodiment of the nozzle damper assembly 10 which is to be found illustrated in Figures

2-6 of the drawing. Or, the nozzle damper assembly 10 may embody a pneumatically operated type of damper blade operating means generally designated by the reference numeral 74 that is utilized in the embodiment of the nozzle damper assembly 10 which is depicted in
5 Figures 7-10 of the drawing.

Attention will be directed herein first to the manually operated form of damper blade operating means, i.e., the damper blade operating means 28 utilized in the embodiment of nozzle damper assembly 10 depicted in Figures 2-6 of the drawing. For this
10 purpose, reference will be had in particular to Figures 4 and 6 of the drawing. To this end, the damper blade operating means 28, as best understood with reference to Figure 4 of the drawing, includes a torque arresting device assembly, generally designated by the reference numeral 76. The torque arresting device assembly 76 in
15 turn includes a lever arm denoted by the reference numeral 78. As best seen with reference to Figure 6 of the drawing, the lever arm 78 has one end thereof securely fastened, through the use of any conventional form of fastening means (not shown) suitable for use for such a purpose, to the end 42b of the shaft member 42. In a manner
20 to be described more fully hereinafter, the lever arm 78 is operative to impart movement to the shaft member 42 and therethrough to the damper blade 18 with which the shaft member 42 is cooperatively associated.

Continuing with the description of the damper blade
25 operating means 28 utilized in the embodiment of the nozzle damper assembly 10 depicted in Figures 2-6 of the drawing, the lever arm 78 is designed to be locked in position such as to thereby fix the angular positions of the damper blades 16 and 18 relative to each other. To this end, the lever arm 78 is locked in position by means
30 of a torque arresting knob denoted by the reference numeral 80 which cooperates with a pair of locking members 82 and 84 such as to effect the capture of the lever arm 78 between the locking members 82 and 84 in the manner shown in Figure 4 of the drawing. Namely, by releasing the torque arresting knob 80 the lever arm 78 is free to move
35 relative to the locking members 82 and 84 when rotation is imparted to the lever arm 78 whereby the lever arm 78 pivots about the end 42b of the shaft member 42. In accord with the illustrated embodiment of

the invention, the locking member 84 preferably is secured to the bearing and stuffing box assembly 44 by virtue of being welded thereto while the locking member 82 in turn preferably is secured to the locking member 84 by virtue of being welded thereto such that a
5 suitably dimensioned space exists between the locking members 82 and 84 so as to permit movement as described hereinbefore of the lever arm 78 between the locking members 82 and 84. Finally, as best seen with reference to Figure 6 of the drawing, the lever arm 78 bears
10 indicia, denoted generally by the reference numeral 86, on its face through the use of which one may determine the angular position that damper blades 16 and 18 bear relative to the sidewalls 32, 34, 36 and 38 of the damper body 30.

With further reference to the damper blade operating means 28, the lever arm 78 is fastened at one end thereof to one end
15 of a connecting link 88 through the use of any conventional form of fastening means suitable for use for such a purpose such as through the use of the pin shown at 90 in Figure 6 of the drawing. The other end of the connecting link 88 is in turn fastened to a handle member denoted by the reference numeral 92 through the use of any
20 conventional form of fastening means suitable for use for such a purpose such as through the use of the pin shown at 94 in Figure 6 of the drawing. The handle member 92, as best understood with reference to Figure 6 of the drawing, has one end thereof securely fastened, through the use of any conventional form of fastening means (not
25 shown) suitable for use for such a purpose, to the end 40b of the shaft member 40. As such, the handle member 92 is operative to impart movement to the shaft member 40 and therethrough to the damper blade 16 with which the shaft member 40 is cooperatively associated. Furthermore, the handle member 92 is operative to impart movement to
30 the connecting link 88 and therethrough to the lever arm 78, which as has been described herein previously is operative to impart movement to the damper blade 18. Thus, movement of the handle member 92 caused by manual operation thereof is operative to cause the damper blades 16 and 18 to move in unison to and fro relative to each other.

35 The pneumatically operated form of damper blade operating means, i.e., the damper blade operating means 74 utilized in the embodiment of nozzle damper assembly 10 depicted in Figures 7-10 of

the drawing will now be discussed. For purposes of this discussion, reference will be had in particular to Figures 8 and 9 of the drawing. Note is also made here of the fact that those components of the nozzle damper assembly 10, which appear in both Figures 2-6 and
5 Figures 7-10 of the drawing and which are essentially the same, are identified for ease of reference by the same reference numerals in both sets of Figures.

The damper blade operating means 74, as best understood with reference to Figure 9 of the drawing, includes a lever arm
10 denoted by the reference numeral 96. As best seen with reference to Figure 9 of the drawing, the lever arm 96 has one end thereof securely fastened, through the use of any conventional form of fastening means (not shown) suitable for use for such a purpose, to the end 42b of the shaft member 42. In a manner to be described more
15 fully hereinafter, the lever arm 96 is operative to impart movement to the shaft member 42 and therethrough to the damper blade 18 with which the shaft member 42 is cooperatively associated.

Continuing with the description of the damper blade operating means 74 utilized in the embodiment of the nozzle damper
20 assembly 10 depicted in Figures 7-10 of the drawing, the lever arm 96 is fastened at the other end thereof to one end of a connecting link 98 through the use of any conventional form of fastening means suitable for use for such a purpose such as through the use of the pin shown at 100 in Figure 9 of the drawing. The other end of the
25 connecting link 98 is in turn fastened to a lever denoted by the reference numeral 102 through the use of any conventional form of fastening means suitable for use for such a purpose such as through the use of the pin shown at 104 in Figure 9 of the drawing.

The lever 102, as best understood with reference to
30 Figure 9 of the drawing, is securely fastened intermediate the ends thereof, through the use of any conventional form of fastening means (not shown) suitable for use for such a purpose, to the end 40b of the shaft member 40. The other end of the lever 102 is fastened through the use of any conventional form of fastening means suitable
35 for use for such a purpose such as through the use of the pin shown at 106 in Figure 9 of the drawing to a clevis denoted by the reference numeral 108, which in known fashion is operatively

connected to an air cylinder of conventional construction denoted by the reference numeral 110. The air cylinder 110 is supported in mounted relation on the damper body 30 such that movement of the piston of the air cylinder 110 is initiated by movement of the clevis 108 and thereby of the lever 102 in addition, which in turn causes the connecting link 98 connected thereto to also move as well as the lever arm 96 connected to the connecting link 98 whereby the damper blades 16 and 18 are caused to move relative to each other to and fro in unison. Operation of the air cylinder 110 may be initiated in many ways. For example, the air cylinder 110 can be connected in circuit relation with the pressure sensing equipment 20 and 22 of the flow measurement means of the nozzle damper assembly 10 such that in response to signals transmitted thereto based on the sensings made by the pressure sensing equipment 20 and 22 the air cylinder 110 can be actuated in order to position the damper blades 16 and 18 as required in order to effectuate the positioning of the damper blades 16 and 18 as required in order to achieve the desired flow rate through the duct 12. On the other hand, the actuation of the air cylinder 110 may be accomplished in any number of other ways, e.g., manually, etc.

However, in accord with the illustrated embodiment of the damper blade operating means 74 of the nozzle damper assembly 10 of the present invention, actuation of the air cylinder 110 of the damper blade operating means 74 is effected in the following manner. An electrically operated, preferably a D.C. operated, actuator denoted by the reference numeral 112 is connected, as best understood with reference to Figure 10 of the drawing, through a coupling device of conventional construction, denoted by the reference numeral 114, to the shaft member 40. As shown in Figure 10, the D.C. operated actuator 112 is preferably housed in the enclosure denoted by the reference numeral 116. The D.C. operated actuator 112 is thus operative to impart rotation through the coupling device 114 to the shaft member 40. As a consequence of this rotation of the shaft member 40, movement is imparted to the lever 102 and therefrom through the connecting link 98 to the lever arm 96. Movement of the lever arm 96 effectuates in turn rotation of the shaft member 42 and concomitantly the positioning of the damper blade 16 that is

cooperatively associated therewith. Finally, the air cylinder 110 is operative to maintain the damper blades 16 and 18 fixed in their respective position until such time as the positions of the damper blades 16 and 18 are changed as a consequence of the D.C. operated
5 actuator 112 having once again been actuated. With further reference to Figure 10 of the drawing, a position indicator seen therein at 118 may be cooperatively associated with the D.C. operated actuator 112 for purposes of enabling one to easily identify the positions then being occupied by the damper blades 16 and 18. In this regard, the
10 position indicator 118 may be secured through the use of conventional fastening means in the form of, for example, conventional threaded fasteners (not shown) in mounted relation on the bracket denoted by the reference numeral 120 in Figure 10.

The last component of the nozzle damper assembly 10 that
15 has yet to be described herein is the flow measurement means thereof. In accord with the embodiment of the nozzle damper assembly 10 of the present invention illustrated in the drawing, the aforereferenced flow measurement means encompasses pressure sensing equipment depicted schematically at 20 and 22 in Figure 1 of the drawing. With
20 further reference to Figure 1, the pressure sensing equipment 20 as depicted therein is designed to be operative to sense the differential pressure in the duct 12 measured across the nozzle damper assembly 10, whereas the pressure sensing equipment 22 as depicted in Figure 1 is designed to be operative to sense the static
25 pressure in the duct 12 upstream of the nozzle damper assembly 10. These sensings made with the pressure sensing equipment 20 and 22 can in turn be converted in the manner described in detail hereinbefore into measurements of the flow in the duct 12 through the nozzle damper assembly 10. Moreover, the flow measurements thus made can be
30 employed for purposes of establishing the relative positions of the damper blades 16 and 18 of the nozzle damper assembly 10 of the present invention in the duct 12, and thereby enable control to be exercised over the rate at which a gaseous medium is flowing through the duct 12.

35 Reference will next be had to Figures 11 and 12 of the drawing. Figure 11 comprises a graphical depiction of one aspect of the performance of the nozzle damper assembly 10 of the present

invention. Namely, the line denoted by the reference numeral 122 is a plot of the pressure loss measured as a percentage of differential pressure plotted against damper angle expressed in degrees wherein the damper angle referred to herein is that of the damper blades 16 and 18 of the nozzle damper assembly 10 of the present invention measured relative to the sidewalls 32, 34, 36 and 38 of the damper body 30 with the nozzle damper assembly 10 being installed in a duct such as the duct 12 depicted in Figure 1 of the drawing.

Figure 12 comprises a graphic depiction of another aspect of the performance of the nozzle damper assembly 10 of the present invention. To this end, Figure 12 comprises a plurality of plots of mass flow rate expressed in kilograms per hour plotted against differential pressure expressed in millimeters of H₂O for various damper angles. More specifically, in Figure 12 the lines 124, 126, 128, 130, 132, 134, 136, 138 and 140 are such plots of mass flow rate against differential pressure for damper angles of 85°, 80°, 75°, 70°, 65°, 60°, 55°, 50° and 45°, respectively.

Thus, in accordance with the present invention there has been provided a new and improved flow control device that is suitable for use for purposes of effectuating control over the flow of a gaseous medium through a conduit. As well, there has been provided in accord with the present invention a flow control device that possesses the capability of being able to not only control the flow but also the capability of being able to simultaneously measure the flow of a gaseous medium through a conduit. Moreover, in accordance with the present invention there has been provided a flow measuring and control device that is particularly suited for use in measuring and controlling the air flow entering exhaustor-type mills. Also, there has been provided in accord with the present invention a flow measuring and control device that is particularly suited for use in measuring and controlling the air flow entering other forms of equipment which are employed in power generation applications. Further, in accordance with the present invention there has been provided a flow measuring and control device that is particularly suited for use in measuring and controlling the flow of a gaseous medium through a conduit which is characterized in that it is possible therewith to handle a wider range of flow rates than that

which is possible with a fixed throat area device such as a venturi or flow nozzle. In addition, there has been provided in accord with the present invention a flow measuring and control device that is particularly suited for use in measuring and controlling the flow of a gaseous medium through a conduit which is characterized in that the subject flow measuring and control device possesses the capability of enabling a much wider range of turndown ratios to be attained therewith, e.g., up to 40 to 1, as contrasted to prior art forms of flow control devices which oftentimes have been limited to turndown ratios of 4 to 1. Furthermore, in accordance with the present invention there has been provided a flow measuring and control device that is particularly suited for use in measuring and controlling the flow of a gaseous medium through a conduit which is characterized in that it possesses the capability of being either manually operated or remotely operated. Additionally, there has been provided in accord with the present invention a flow measuring and control device that is particularly suited for use in measuring and controlling a gaseous medium through a conduit which is characterized in that it is relatively short in length so as to, therefore, facilitate its installation in a conduit. Penultimately, in accordance with the present invention there has been provided a flow measuring and control device that is particularly suited for use in measuring and controlling the flow of a gaseous medium through a conduit which is characterized in that it embodies a modular form of construction thereby facilitating the manufacture, transport and installation thereof. Finally, there has been provided in accord with the present invention a flow measuring and control device that is particularly suited for use in measuring and controlling the flow of a gaseous medium through a conduit which is equally applicable for employment in new installations as well as in retrofit applications.

While several embodiments of our invention have been shown, it will be appreciated that modifications thereof, some of which have been alluded to hereinabove, may still be readily made thereto by those skilled in the art. We, therefore, intend by the appended claims to cover the modifications alluded to herein as well as all the other modifications which fall within the true spirit and scope of our invention.

What is claimed is:

1. A nozzle damper assembly for installation in a duct operative for measuring and controlling the flow of a gaseous medium through the duct comprising:

- 5 a. enclosure means mountable in installed relation at a location along the length of the duct;
- b. shaft means supported for movement in said enclosure means;
- 10 c. damper blade means rotatably mounted on said shaft means for movement within said enclosure means;
- d. damper blade operating means operatively connected to said damper blade means, said damper blade operating means being operative to effect the movement of said shaft means and therethrough the movement of said damper blade means within said enclosure means; and
- 15 e. flow measurement means located upstream and downstream of said damper blade means, said flow measurement means being operative to measure the flow of the gaseous medium through the nozzle damper assembly such that control can be exercised over the flow of the gaseous medium through the nozzle damper assembly and thereby through the duct based on the measurements obtained through the operation of said flow measurement means.
- 20
- 25

2. The nozzle damper assembly as set forth in Claim 1 wherein said enclosure means includes a damper body embodying four sidewalls with two of said four sidewalls extending in parallel relation to one another and in perpendicular relation to the other two of said four sidewalls.

30

3. The nozzle damper assembly as set forth in Claim 2 wherein said shaft means includes a pair of shaft members supported in spaced relation one to another in said damper body.

4. The nozzle damper assembly as set forth in Claim 3 wherein said damper blade means includes a pair of damper blades, one of said pair of damper blades being mounted on one of said pair of shaft members for movement therewith, and the other one of said pair

35

of damper blades being mounted on the other one of said pair of shaft members for movement therewith.

5 5. The nozzle damper assembly as set forth in Claim 4 wherein each of said pair of damper blades comprises a 90° arc.

6 6. The nozzle damper assembly as set forth in Claim 5 wherein each of said pair of damper blades has a radius equal to one-half of the height of the duct.

7 7. The nozzle damper assembly as set forth in Claim 4 wherein said damper blade operating means includes lever means
10 supported in mounted relation on said pair of shaft members and connecting link means interconnecting said lever means such that said pair of shaft members are made to move in unison.

8 8. The nozzle damper assembly as set forth in Claim 7 wherein movement is imparted to said lever means manually.

15 9. The nozzle damper assembly as set forth in Claim 7 wherein movement is imparted to said lever means pneumatically.

20 10. The nozzle damper assembly as set forth in Claim 7 wherein said flow measurement means includes first pressure sensing equipment located upstream of said pair of damper blades and second pressure sensing equipment located downstream of said pair of damper blades, said first pressure sensing equipment being operative to sense static pressure and said second pressure sensing equipment being operative to sense differential pressure.

25 11. A nozzle damper assembly for installation in a duct operative for controlling the flow of a gaseous medium through the duct comprising:

- 30 a. enclosure means mountable in installed relation at a location along the length of the duct;
- b. shaft means supported for movement in said enclosure means;
- c. damper blade means rotatably mounted on said shaft means for movement within said enclosure means, said damper blade means including a pair of damper blades, each of said pair of damper blades
35 comprising a 90° arc and having a radius equal to one-half of the height of the duct; and

5 d. damper blade operating means operatively connected to said damper blade means, said damper blade operating means being operative to effect the movement of said shaft means and therethrough the movement of said pair of damper blades within said enclosure means.

10 12. The nozzle damper assembly as set forth in Claim 11 wherein said damper blade operating means includes lever means supported in mounted relation on said shaft means and connecting link means interconnecting said lever means such that said pair of damper blades are made to move in unison.

13. The nozzle damper assembly as set forth in Claim 11 wherein movement is imparted to said lever means manually.

15 14. The nozzle damper assembly as set forth in Claim 11 wherein movement is imparted to said lever means pneumatically.

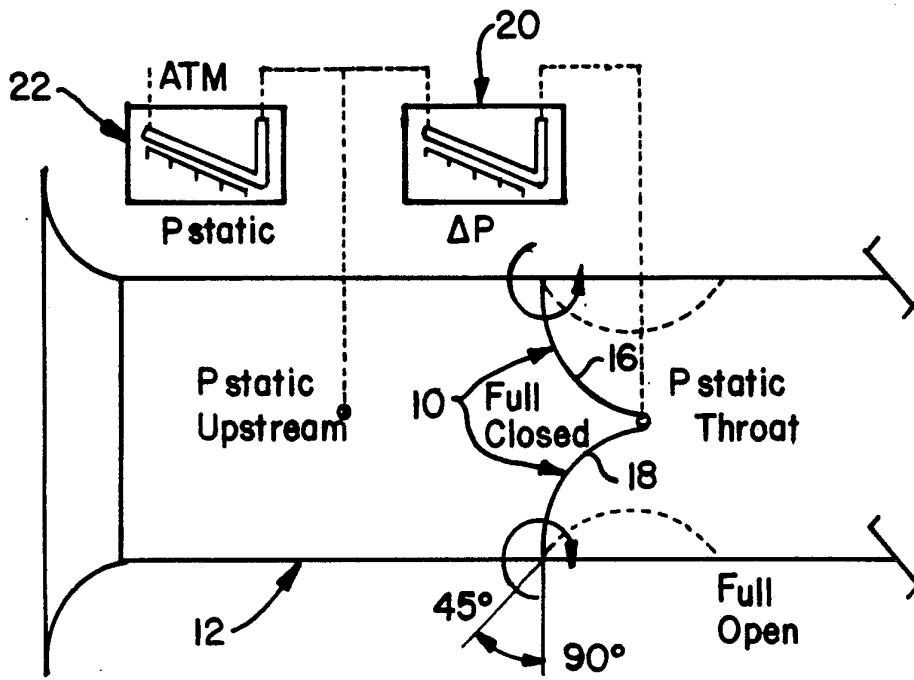

Fig. 1

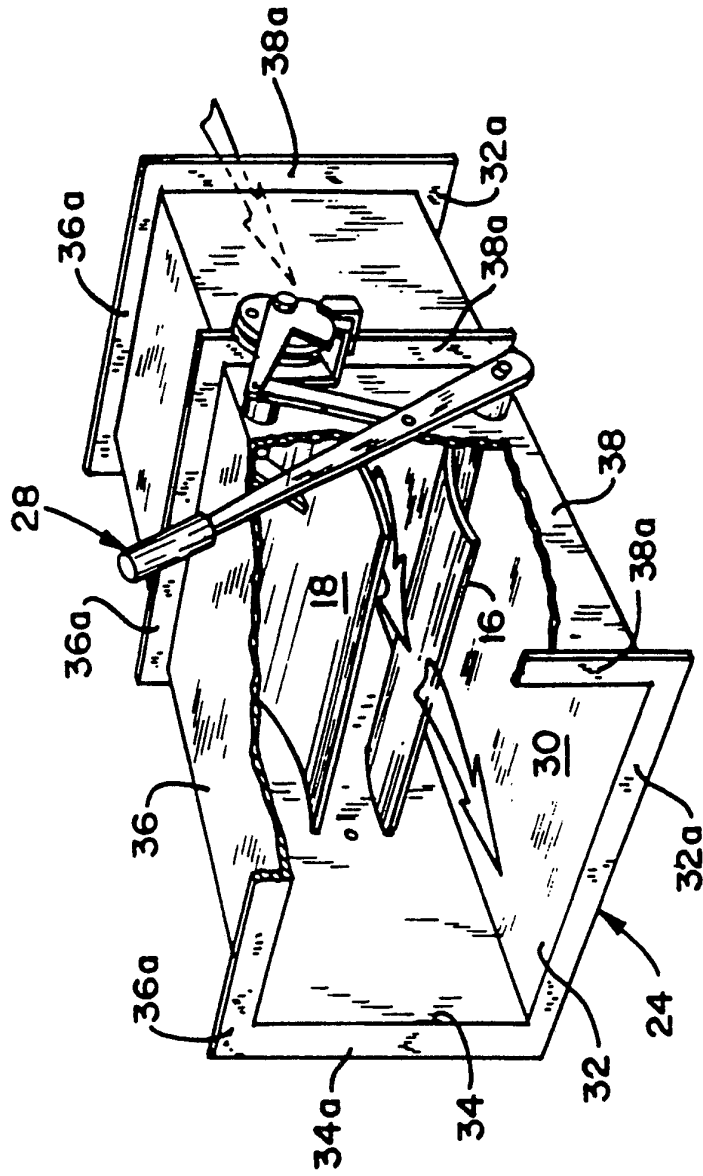

Fig. 2

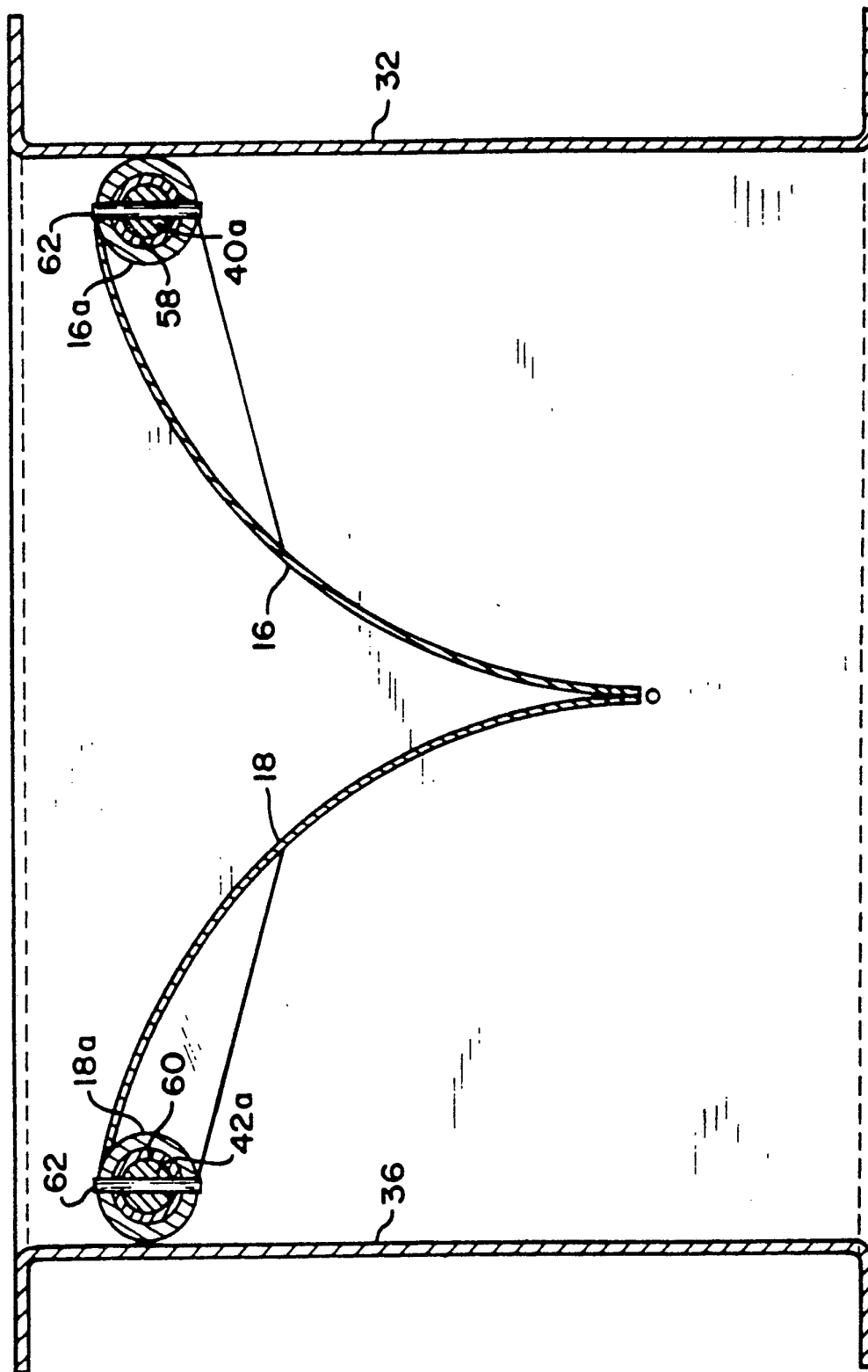

Fig. 3

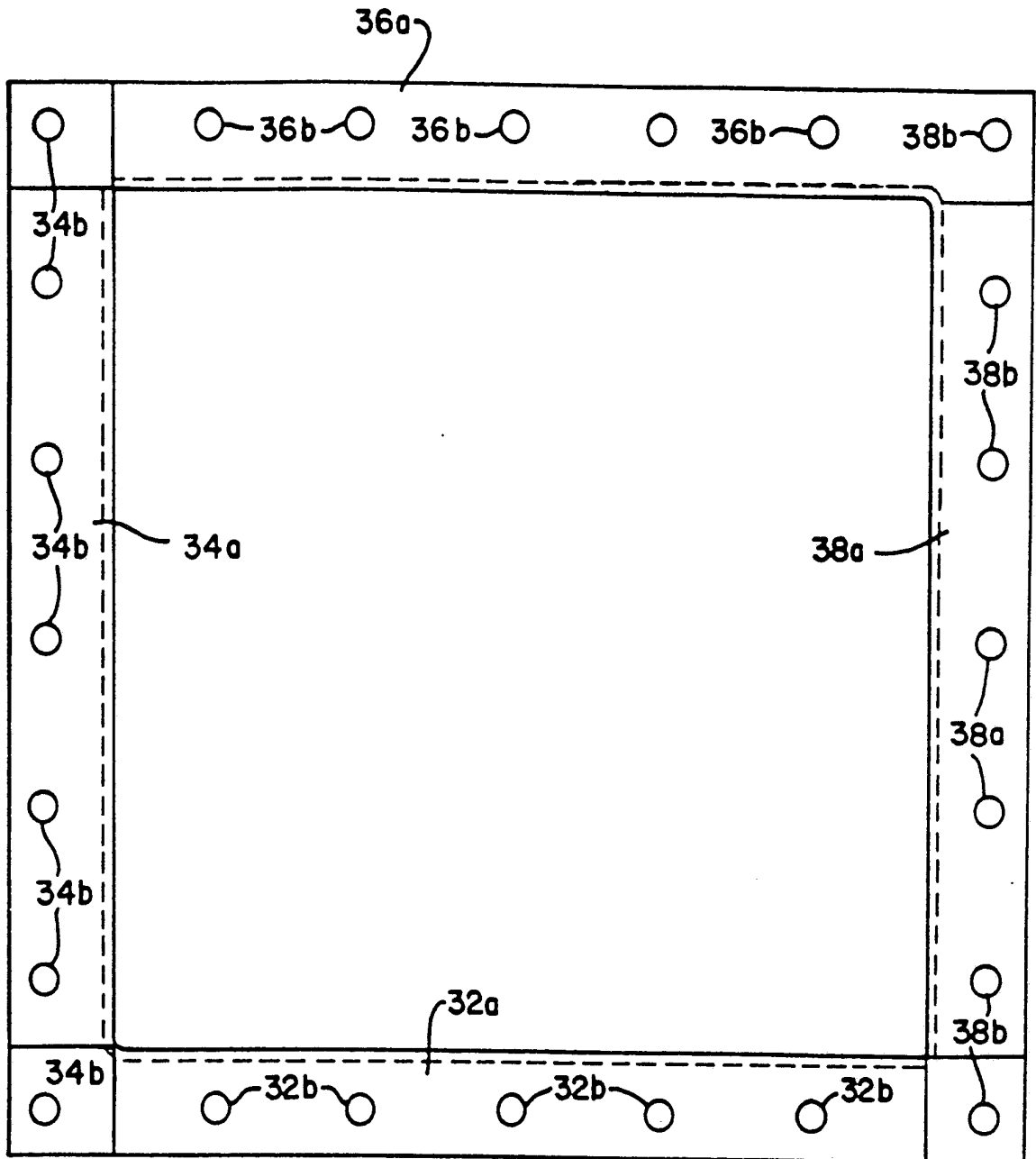

Fig. 5

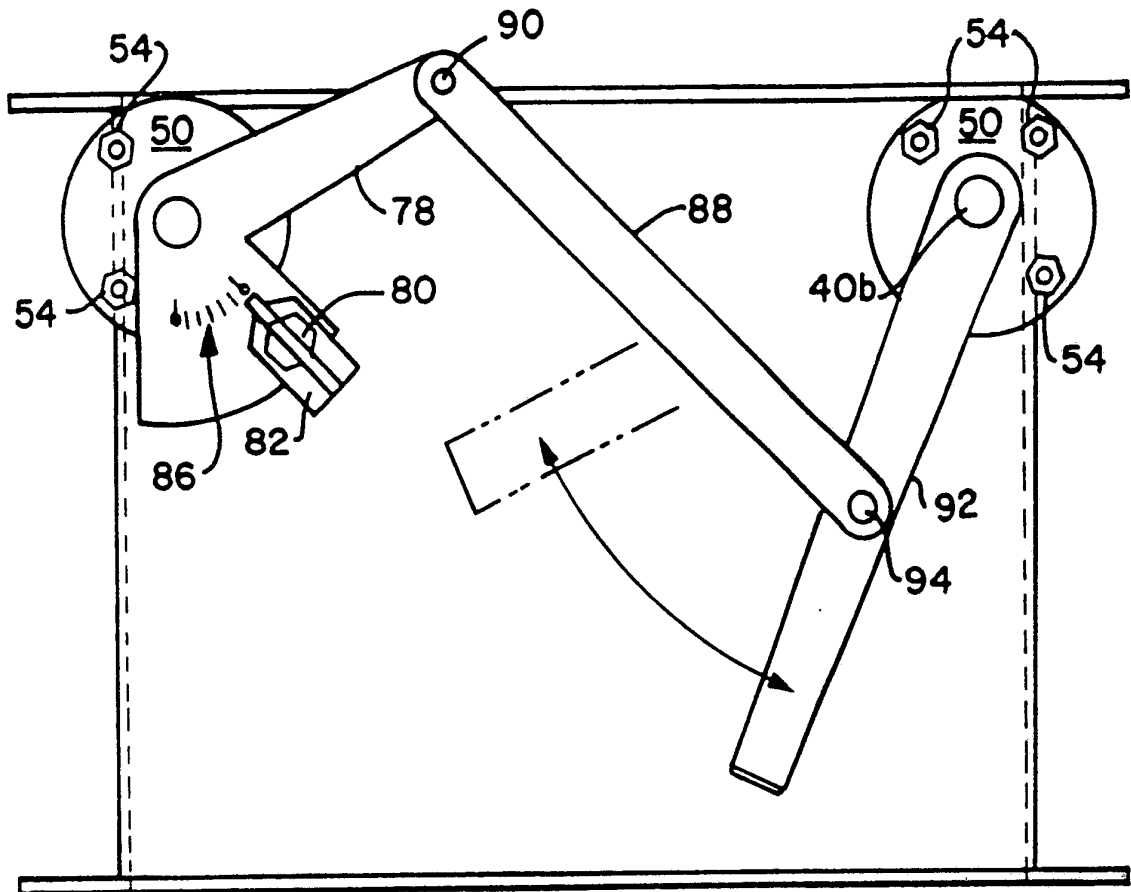

Fig. 6

SUBSTITUTE SHEET

7/12

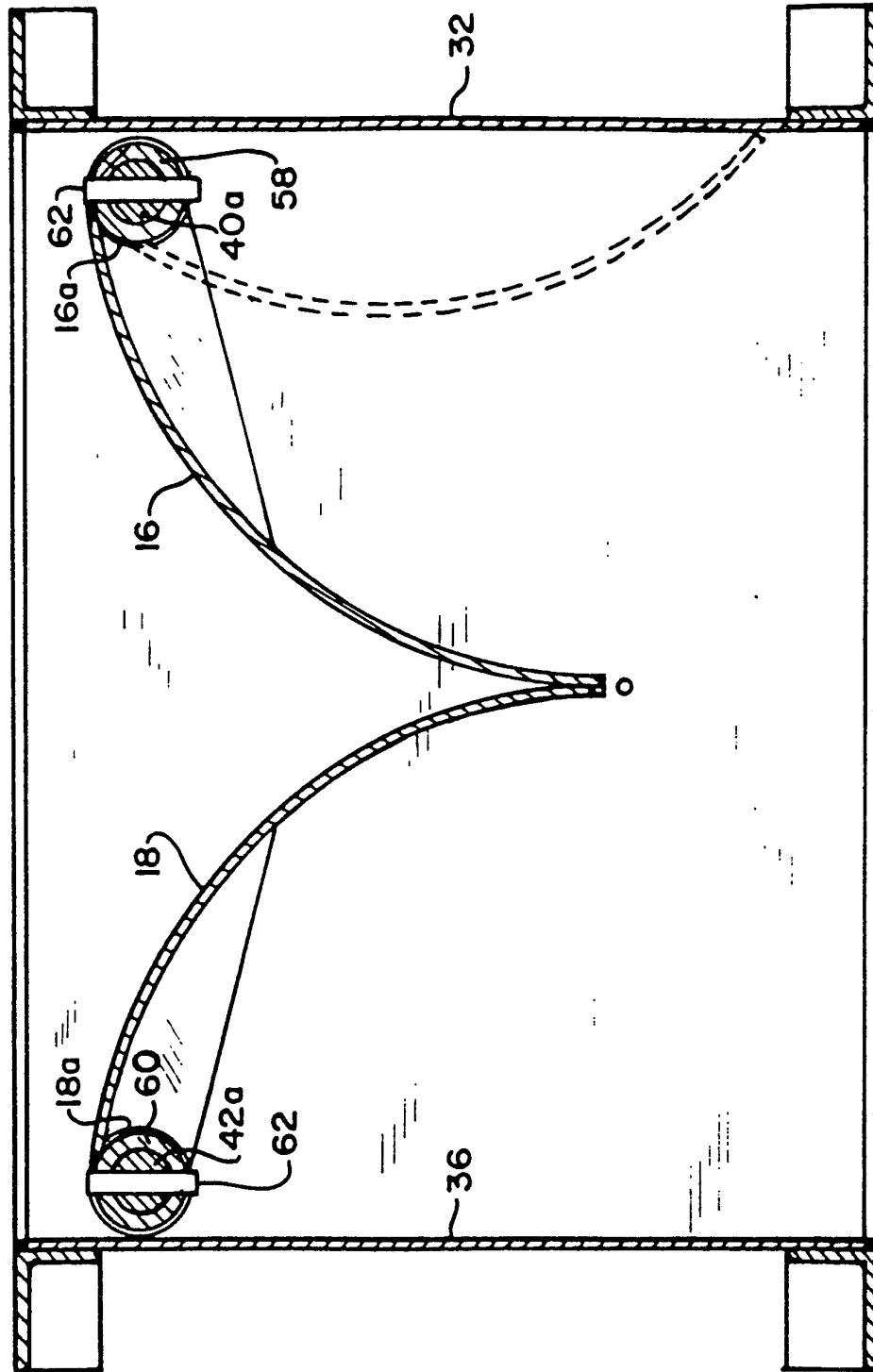

Fig. 7

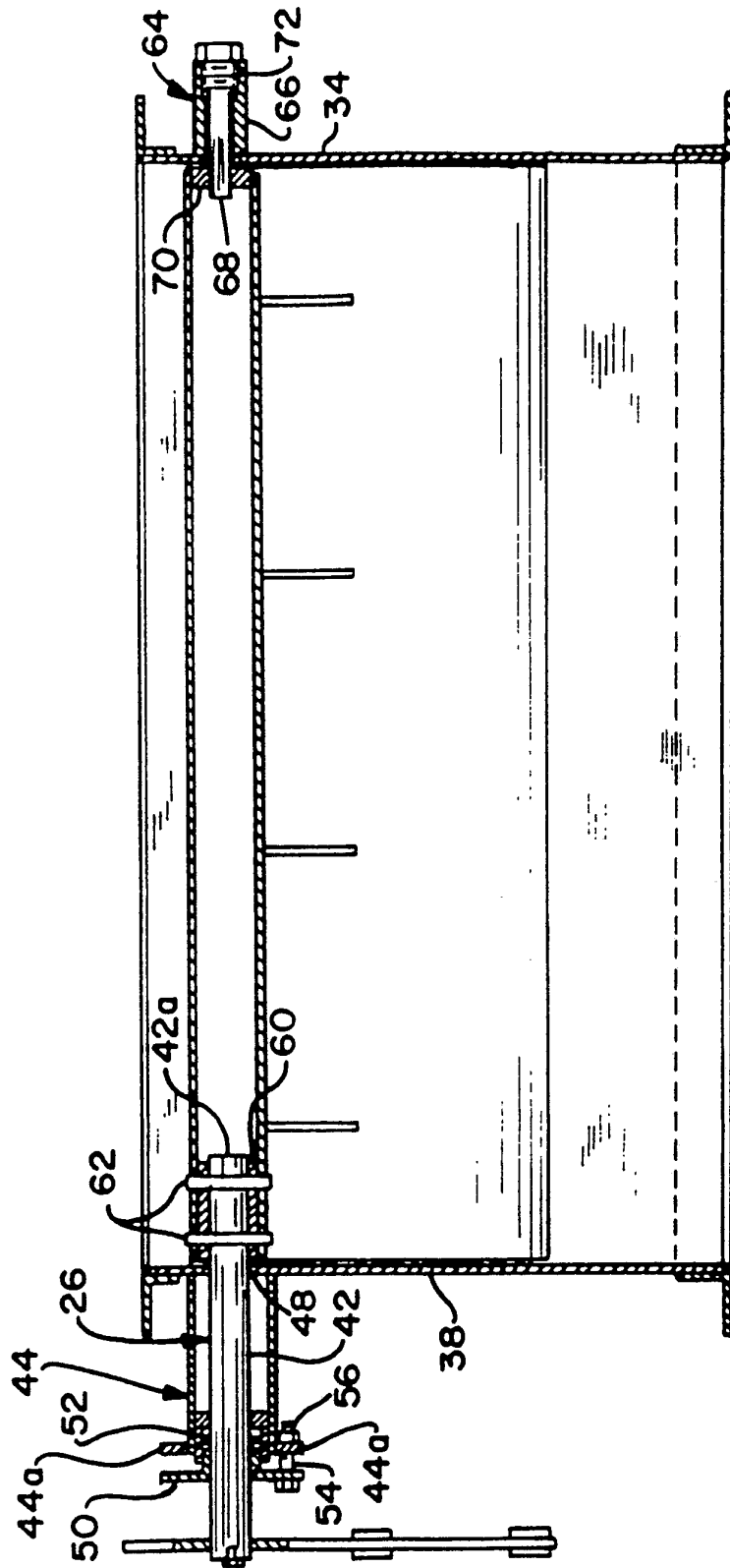

Fig. 8

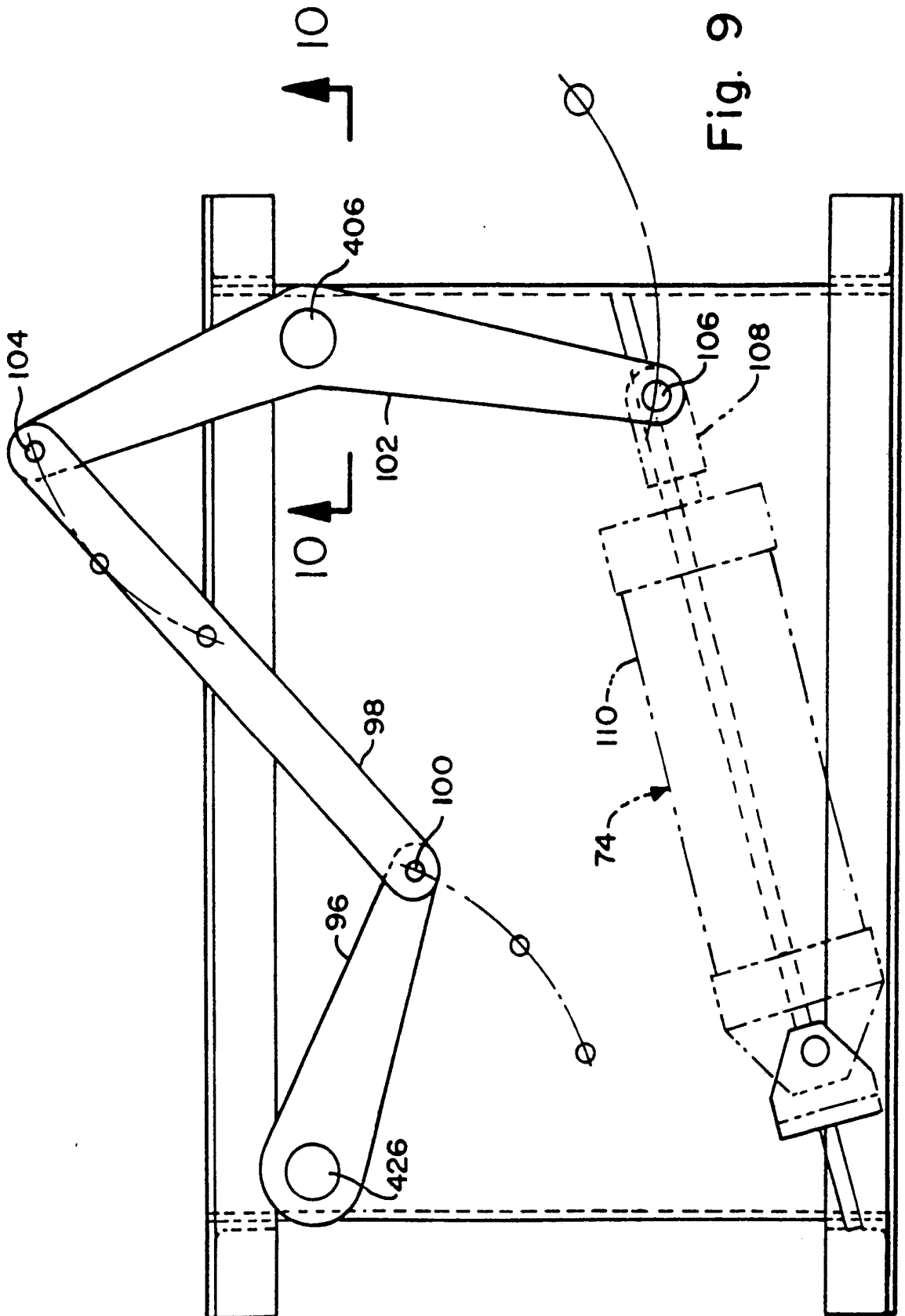

Fig. 9

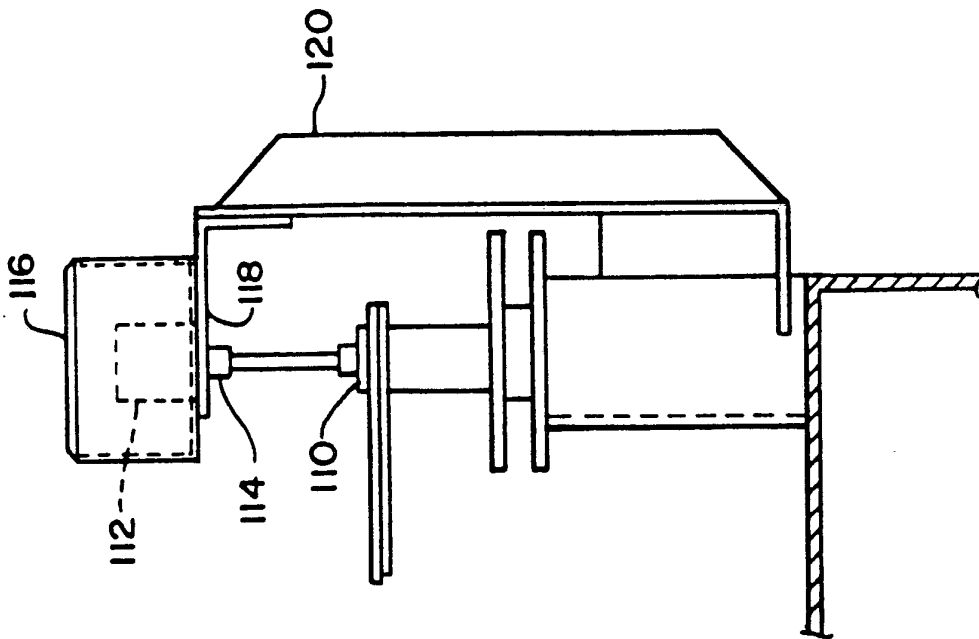
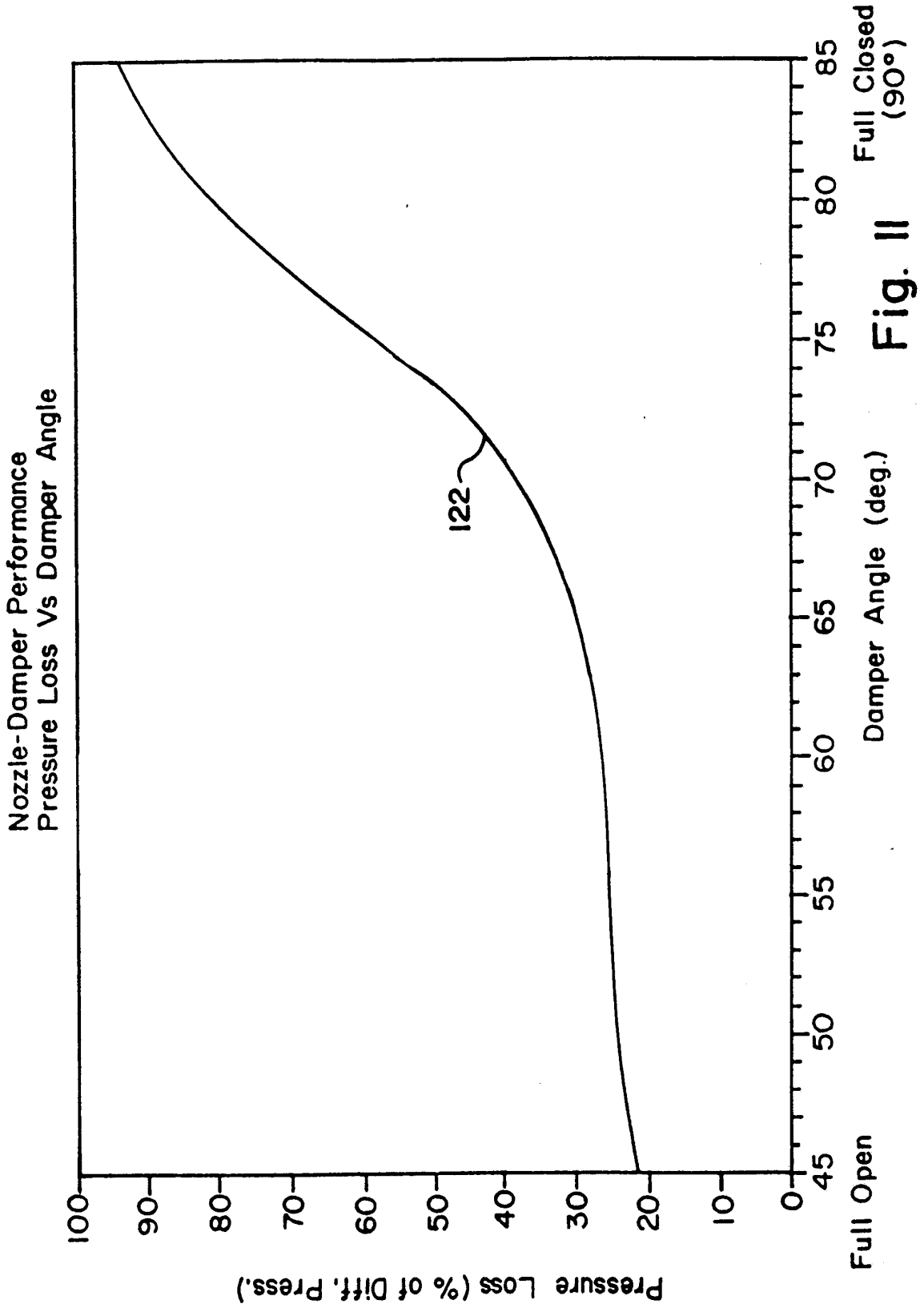
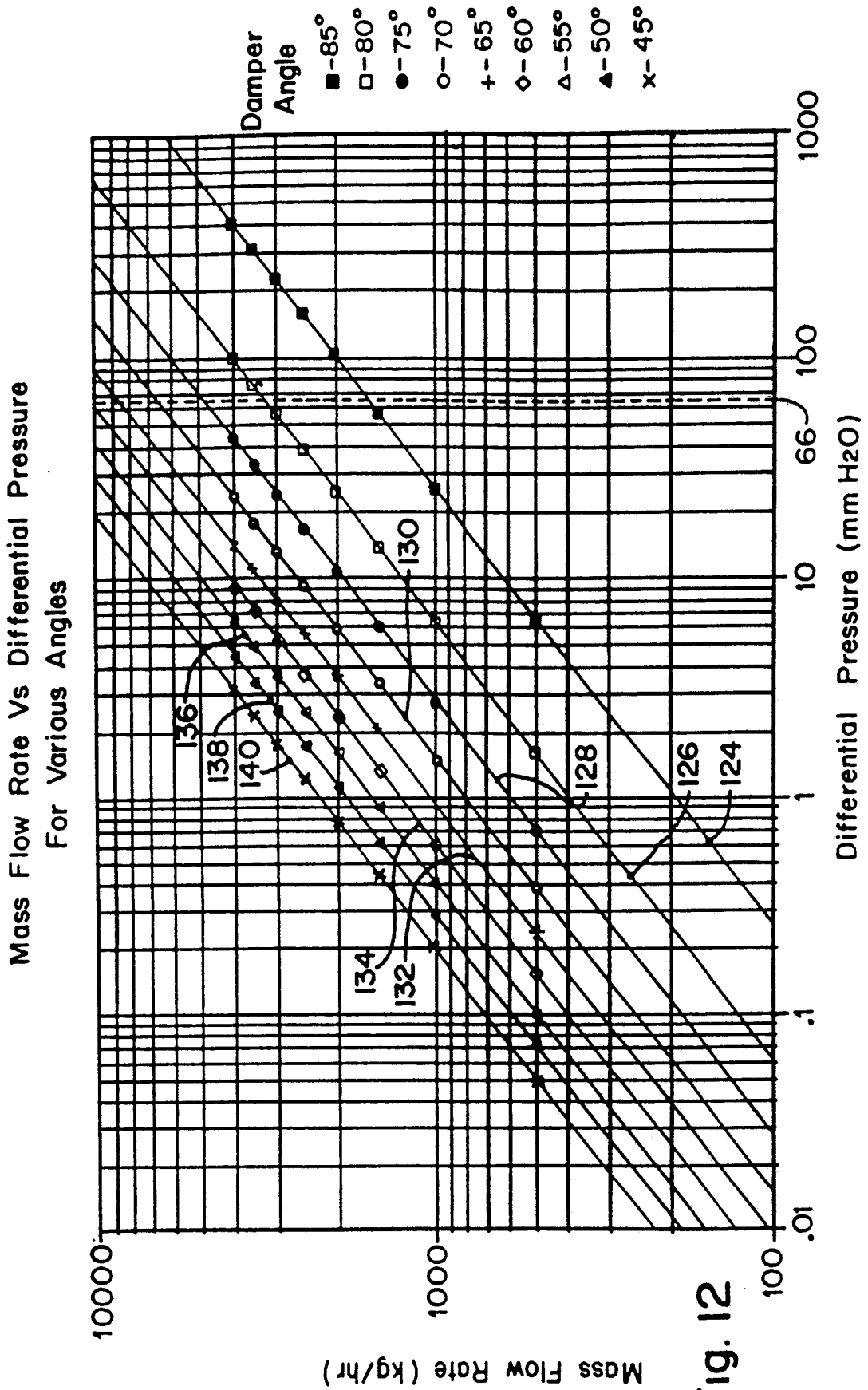

Fig. 10



12/12



SUBSTITUTE SHEET

INTERNATIONAL SEARCH REPORT

PCT/US 92/08375

International Application No

I. CLASSIFICATION OF SUBJECT MATTER (if several classification symbols apply, indicate all)⁶According to International Patent Classification (IPC) or to both National Classification and IPC
Int.Cl. 5 G01F1/40**II. FIELDS SEARCHED**Minimum Documentation Searched⁷

Classification System	Classification Symbols
Int.Cl. 5	G01F ; F16K

Documentation Searched other than Minimum Documentation
to the Extent that such Documents are Included in the Fields Searched⁸**III. DOCUMENTS CONSIDERED TO BE RELEVANT⁹**

Category ¹⁰	Citation of Document, ¹¹ with indication, where appropriate, of the relevant passages ¹²	Relevant to Claim No. ¹³
X	US,A,3 888 458 (BUBNIAK) 10 June 1975	1,2
Y	see the whole document	10
X	DE,C,394 558 (ROUCKA) 23 April 1924	1
Y	see the whole document	2-7,11, 12
Y	US,A,3 417 961 (C. SHORROCK) 24 December 1968 see figures	2-7, 10-12
A	DE,C,801 871 (JUSTUS) 25 January 1951 see figures	1-4,6-8, 11-13
	-/--	

¹⁰ Special categories of cited documents :

- "A" document defining the general state of the art which is not considered to be of particular relevance
- "E" earlier document but published on or after the international filing date
- "L" document which may throw doubts on priority claim(s) or which is cited to establish the publication date of another citation or other special reason (as specified)
- "O" document referring to an oral disclosure, use, exhibition or other means
- "P" document published prior to the international filing date but later than the priority date claimed

"T" later document published after the international filing date or priority date and not in conflict with the application but cited to understand the principle or theory underlying the invention

"X" document of particular relevance; the claimed invention cannot be considered novel or cannot be considered to involve an inventive step

"Y" document of particular relevance; the claimed invention cannot be considered to involve an inventive step when the document is combined with one or more other such documents, such combination being obvious to a person skilled in the art.

"&" document member of the same patent family

IV. CERTIFICATION

Date of the Actual Completion of the International Search

13 JANUARY 1993

Date of Mailing of this International Search Report

10. 02. 93

International Searching Authority

EUROPEAN PATENT OFFICE

Signature of Authorized Officer

ROSE A.R.P.

III. DOCUMENTS CONSIDERED TO BE RELEVANT (CONTINUED FROM THE SECOND SHEET)		
Category °	Citation of Document, with indication, where appropriate, of the relevant passages	Relevant to Claim No.
A	US,A,3 854 500 (COOPER) 17 December 1974 cited in the application see column 1, line 57 - column 1, line 60; figures -----	9, 14

**ANNEX TO THE INTERNATIONAL SEARCH REPORT
ON INTERNATIONAL PATENT APPLICATION NO.**

US 9208375
SA 65818

This annex lists the patent family members relating to the patent documents cited in the above-mentioned international search report. The members are as contained in the European Patent Office EDP file on The European Patent Office is in no way liable for these particulars which are merely given for the purpose of information. 13/01/93

Patent document cited in search report	Publication date	Patent family member(s)	Publication date
US-A-3888458	10-06-75	US-A- 3817099 US-A- 3818933	18-06-74 25-06-74
DE-C-394558		None	
US-A-3417961		None	
DE-C-801871		None	
US-A-3854500	17-12-74	JP-A- 49097329	13-09-74

EPO FORM P0479

For more details about this annex : see Official Journal of the European Patent Office, No. 12/82