

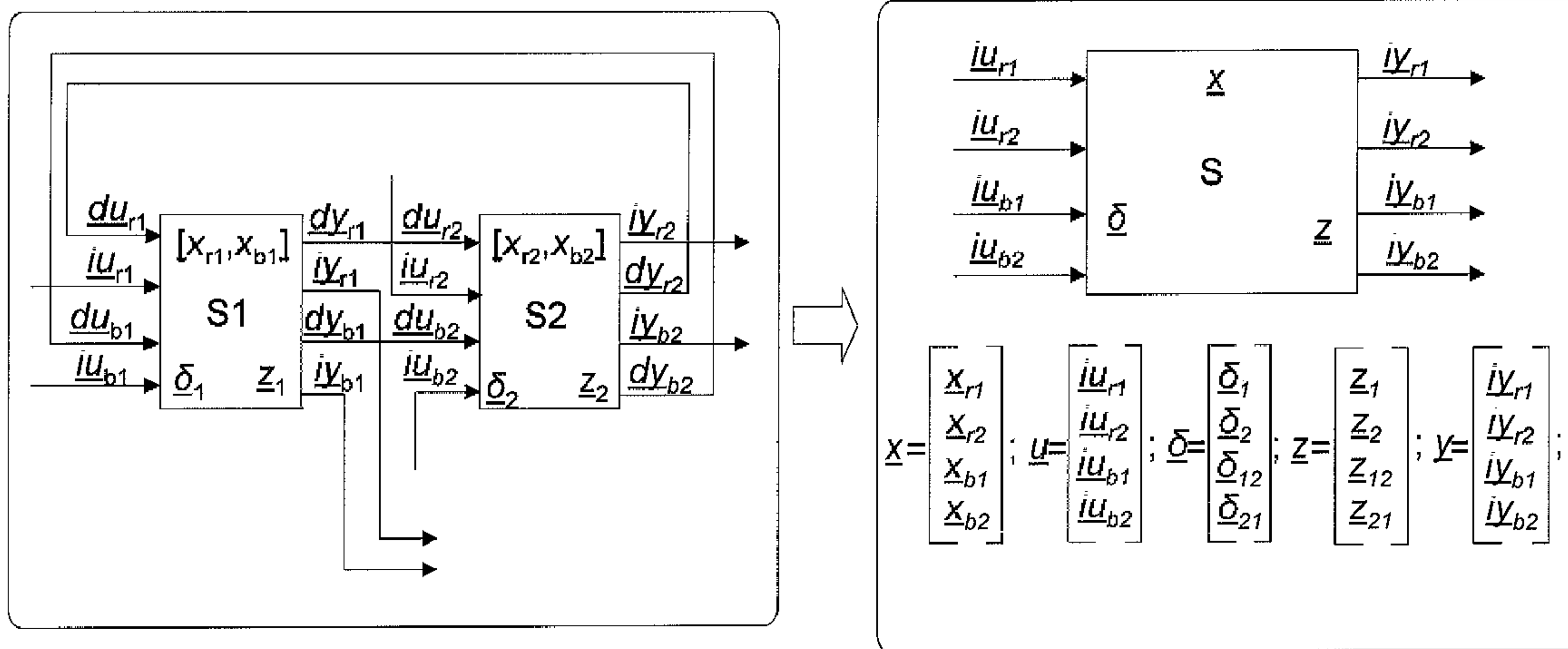

(86) Date de dépôt PCT/PCT Filing Date: 2010/05/25
 (87) Date publication PCT/PCT Publication Date: 2010/12/23
 (45) Date de délivrance/Issue Date: 2018/02/27
 (85) Entrée phase nationale/National Entry: 2011/12/16
 (86) N° demande PCT/PCT Application No.: EP 2010/057148
 (87) N° publication PCT/PCT Publication No.: 2010/149444
 (30) Priorité/Priority: 2009/06/24 (EP09163541.7)

(51) Cl.Int./Int.Cl. *G05B 13/04* (2006.01),
G05B 17/02 (2006.01)
 (72) Inventeurs/Inventors:
GALLESTEY ALVAREZ, EDUARDO, CH;
POLAND, JAN, CH;
STADLER, KONRAD, CH;
GAULOCHER, SEBASTIAN, CH;
FOROUSH, HAMED SHISHEH, CH
 (73) Propriétaire/Owner:
ABB RESEARCH LTD, CH
 (74) Agent: NORTON ROSE FULBRIGHT CANADA
LLP/S.E.N.C.R.L., S.R.L.

(54) Titre : ESTIMATION DES ETATS INITIAUX D'UN MODELE DE SYSTEME, POUR CONTROLER UN PROCESSUS INDUSTRIEL
 (54) Title: ESTIMATING INITIAL STATES OF A SYSTEM MODEL FOR CONTROLLING AN INDUSTRIAL PROCESS



(57) **Abrégé/Abstract:**

According to the present invention, model-based control of industrial processes is promoted by using a merged MLD system model for both the estimation and subsequent control of the industrial process, thus simplifying and expediting the set-up of model based

(57) Abrégé(suite)/Abstract(continued):

control together with accurate estimation of initial states. In particular, an optimization of an objective function is performed, wherein the objective function includes a difference between an observed quantity and an output variable of a Mixed Logical Dynamic (MLD) system model of the industrial process. The optimization is performed as a function of state variables of the MLD system model, over a number of time steps in the past, and subject to constraints defined by the MLD system model's dynamics. The optimizing values of the state variables are retained as estimated initial states for the subsequent control of the industrial process in a model-based manner including the very same MLD system model. The single MLD system model is a combination or merger of individual MLD subsystem models representing the sub-processes of the industrial process, and may thus be elaborated by a commissioning engineer during a customization step on a plant site, and hence at a comparably late moment during plant execution.

(12) INTERNATIONAL APPLICATION PUBLISHED UNDER THE PATENT COOPERATION TREATY (PCT)

(19) World Intellectual Property Organization
International Bureau(43) International Publication Date
29 December 2010 (29.12.2010)(10) International Publication Number
WO 2010/149444 A1(51) International Patent Classification:
G05B 13/04 (2006.01) *G05B 17/02* (2006.01)(21) International Application Number:
PCT/EP2010/057148(22) International Filing Date:
25 May 2010 (25.05.2010)

(25) Filing Language: English

(26) Publication Language: English

(30) Priority Data:
09163541.7 24 June 2009 (24.06.2009) EP(71) Applicant (for all designated States except US): **ABB Research Ltd** [—/CH]; Affolternstrasse 44, CH-8050 Zürich (CH).

(72) Inventors; and

(75) Inventors/Applicants (for US only): **GALLESTEY ALVAREZ, Eduardo** [—/CH]; Winkelackweg 5, CH-5522 Tägerig (CH). **POLAND, Jan** [—/CH]; Wettingerstrasse 7a, CH-5400 Baden (CH). **STADLER, Konrad** [—/CH]; Hofwies 9, CH-8166 Niederweningen (CH). **GAULOCHER, Sebastian** [—/CH]; Innere Altsachen 13, CH-4800 Zofingen (CH). **FOROUSH, Hamed Shisheh** [IR/CH]; Avenue des Bains 11/324, CH-1007 Lausanne (CH).(74) Agent: **MEIER OBERTÜFER, Jürg**; ABB Patent Attorneys, c/o ABB Schweiz AG, Intellectual Property CH-LC/IP, Brown Boveri Strasse 6, CH-5400 Baden (CH).

(81) Designated States (unless otherwise indicated, for every kind of national protection available): AE, AG, AL, AM, AO, AT, AU, AZ, BA, BB, BG, BH, BR, BW, BY, BZ, CA, CH, CL, CN, CO, CR, CU, CZ, DE, DK, DM, DO, DZ, EC, EE, EG, ES, FI, GB, GD, GE, GH, GM, GT, HN, HR, HU, ID, IL, IN, IS, JP, KE, KG, KM, KN, KP, KR, KZ, LA, LC, LK, LR, LS, LT, LU, LY, MA, MD, ME, MG, MK, MN, MW, MX, MY, MZ, NA, NG, NI, NO, NZ, OM, PE, PG, PH, PL, PT, RO, RS, RU, SC, SD, SE, SG, SK, SL, SM, ST, SV, SY, TH, TJ, TM, TN, TR, TT, TZ, UA, UG, US, UZ, VC, VN, ZA, ZM, ZW.

(84) Designated States (unless otherwise indicated, for every kind of regional protection available): ARIPO (BW, GH, GM, KE, LR, LS, MW, MZ, NA, SD, SL, SZ, TZ, UG, ZM, ZW), Eurasian (AM, AZ, BY, KG, KZ, MD, RU, TJ, TM), European (AL, AT, BE, BG, CH, CY, CZ, DE, DK, EE, ES, FI, FR, GB, GR, HR, HU, IE, IS, IT, LT, LU, LV, MC, MK, MT, NL, NO, PL, PT, RO, SE, SI, SK, SM, TR), OAPI (BF, BJ, CF, CG, CI, CM, GA, GN, GQ, GW, ML, MR, NE, SN, TD, TG).

Published:

— with international search report (Art. 21(3))

(54) Title: ESTIMATING INITIAL STATES OF A SYSTEM MODEL FOR CONTROLLING AN INDUSTRIAL PROCESS

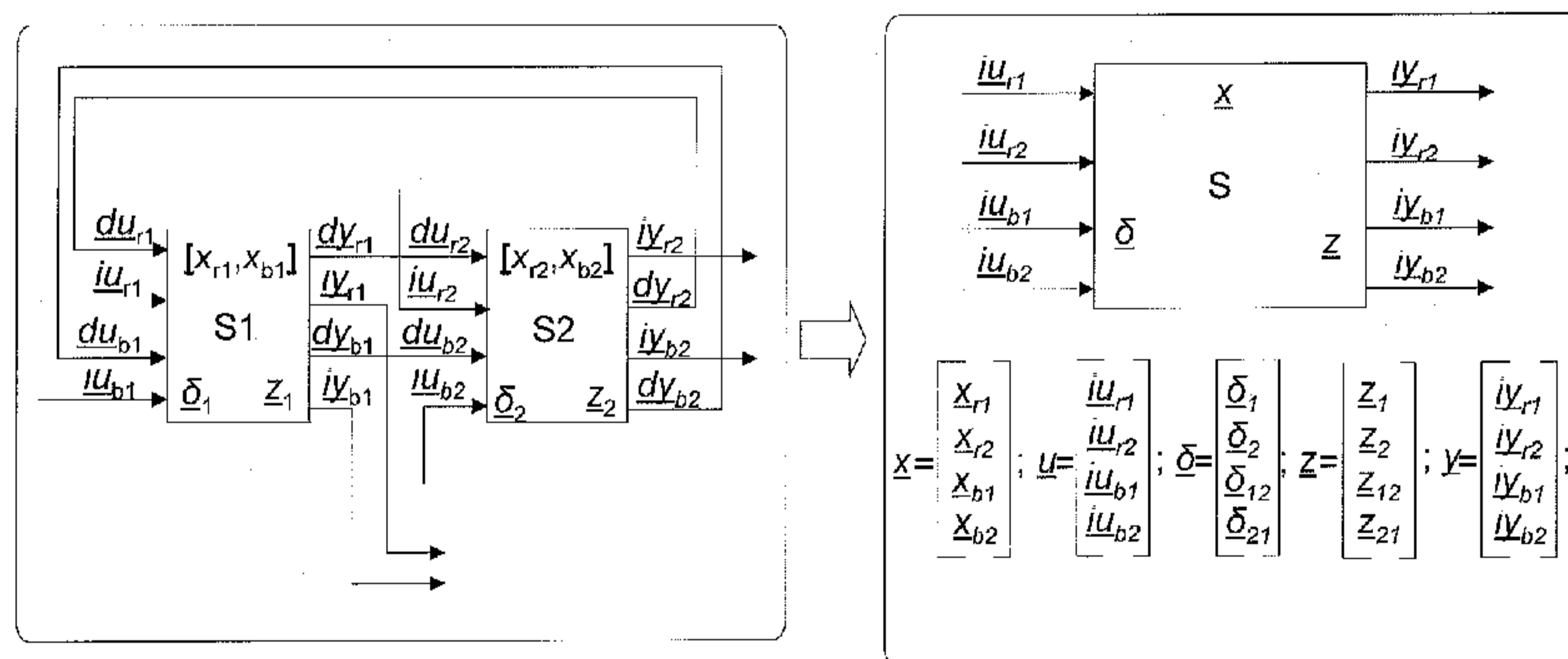

Fig. 4

(57) **Abstract:** According to the present invention, model-based control of industrial processes is promoted by using a merged MLD system model for both the estimation and subsequent control of the industrial process, thus simplifying and expediting the set-up of model based control together with accurate estimation of initial states. In particular, an optimization of an objective function is performed, wherein the objective function includes a difference between an observed quantity and an output variable of a Mixed Logical Dynamic (MLD) system model of the industrial process. The optimization is performed as a function of state variables of the MLD system model, over a number of time steps in the past, and subject to constraints defined by the MLD system model's dynamics. The optimizing values of the state variables are retained as estimated initial states for the subsequent control of the industrial process in a model-based manner including the very same MLD system model. The single MLD system model is a combination or merger of individual MLD subsystem models representing the sub-processes of the industrial process, and may thus be elaborated by a commissioning engineer during a customization step on a plant site, and hence at a comparably late moment during plant execution.



WO 2010/149444 A1

ESTIMATING INITIAL STATES OF A SYSTEM MODEL FOR CONTROLLING AN INDUSTRIAL PROCESS

- 5 The present invention relates to the field of industrial process modelling, optimal control and advanced scheduling.

BACKGROUND OF THE INVENTION

10 Many industries rely on control systems in order to control processes in specific and predictable ways. Correctly defining operating parameters and control strategies for such control systems is vital for the success of the systems, and several different techniques exist for achieving this success. It will be readily appreciated that suitable control systems are vital for a range of different industries, and that the techniques and methods to be discussed below are applicable to a wide range of
15 processes. One example of such a process is level control of interconnected tanks. This is a common problem in many industries, such as the chemical, pharmaceutical, and food industry, the minerals processing industry, the pulp and paper industry, the oil and gas industry, and the water treatment industry. More generally, level control is important in all processes where liquids or suspensions are transformed, stocked,
20 or separated.

A flotation circuit, for example as illustrated in Figure 1 of the accompanying drawings, has the purpose of separating valuable minerals from worthless material. Both of which are contained in a suspension of ground ore in water (so-called pulp). The separation is achieved by exploiting the hydrophobic character of certain
25 minerals, e.g. sphalerite, an important zinc mineral. The plant is usually composed of a number of interconnected flotation cells. Intermediate storage tanks and mixing tanks may be part of such a circuit as well.

The example flotation system shown in Fig.1 comprises a series of flotation tanks. The first tank receives an input flow. The tanks are interconnected using pipes and valves. The third tank in the series has an output for waste material. Each of the tanks has an output for the separated material. The fluid level in each tank is represented by a marking line. Accordingly, the different components that have to be modelled include containers, such as a flotation cell, intermediate storage tank (in most of the cases, this refers to a pump box), and a mixing tank, connectors, meaning pipes, and outlets, sensors, such as volume flow rate, froth layer thickness or pulp level, and valve opening percentage sensors, and actuators, such as control valves, and pumps.

Precise level control of the different flotation cells is of foremost importance for flotation because the froth layer thickness, i.e. the thickness of the froth layer swimming on top of the liquid pulp phase, has a significant influence on the quantity and composition of the concentrate obtained from these cells. More details as well as an introduction to the various control techniques available are disclosed in the article "Model-predictive control of the froth thickness in a flotation circuit", by H. S. Foroush, S. Gaulocher, E. Gallestey, to be presented at Procemin 2009, December 4, 2009, Santiago de Chile.

Model-predictive control (MPC) using a black-box model is an option for performing level control. The main drawback is the necessity of doing lengthy step tests in order to identify a plant model. These tests typically require conditions close to a steady-state, which is a rare case in level control. Furthermore, once a black-box model is identified, it will not be modified during operation anymore. Therefore, it cannot account for process variations or the necessity of using a different linearization point.

Mixed logical dynamical (MLD) systems, as introduced e.g. in the article "Control of Systems Integrating Logic, Dynamics, and Constraints", A. Bemporad and M. Morari, Automatica 35(3), 1999, pp 407-427, represent a mathematical framework for modelling systems described by interacting physical laws, logical rules, and operating constraints, generally called "hybrid systems". MLD systems are determined or described by linear dynamic equations subject to linear mixed-integer inequalities involving both continuous, i.e. real-valued, and binary, i.e. Boolean-valued, variables. The variables include continuous and binary states \underline{x} , inputs \underline{u} and

outputs \underline{y} , as well as continuous auxiliary variables \underline{z} and binary auxiliary variables $\underline{\delta}$, as described in the following equations:

$$\underline{x}(t+1) = A \underline{x}(t) + B_1 \underline{u}(t) + B_2 \underline{\delta}(t) + B_3 \underline{z}(t) \quad (\text{Eqn.1a})$$

$$\underline{y}(t) = C \underline{x}(t) + D_1 \underline{u}(t) + D_2 \underline{\delta}(t) + D_3 \underline{z}(t) \quad (\text{Eqn.1b})$$

$$5 \quad E_2 \underline{\delta}(t) + E_3 \underline{z}(t) \leq E_1 \underline{u}(t) + E_4 \underline{x}(t) + E_5 \quad (\text{Eqn.1c})$$

In general, the variables mentioned are vectors and A, B_i, C, D_i, and E_i are matrices of suitable dimensions.

In order to be well posed, the above MLD system must be such that for any given x(t) and u(t) the values of $\delta(t)$ and z(t) are defined uniquely. Formulations or relationships as Eqns.1 appear naturally when logical statements are written as propositional calculus expressions, or when bounds on the states are set explicitly. Among the advantages of the MLD framework is the possibility to generate automatically the matrices of MLD systems from a high-level description. MLD systems generalize a wide set of models, among which there are linear hybrid systems and even nonlinear systems whose nonlinearities can be expressed or at least suitably approximated by piecewise linear functions.

EP1 607 809 describes the combination of arbitrarily connected MLD systems in order to model and control complex industrial systems. In EP 1 607 809, a combined model is arrived that makes use of auxiliary variables to provide the overall model. In addition, EP 1 607 809 describes the use of Model Predictive Control (MPC) using a merged MLD system. As described above, MPC is a procedure of solving an optimal-control problem, which includes system dynamics and constraints on the system output, state and input variables. The main idea of model predictive control is to use a model of the plant or process, valid at least around a certain operating point, to predict the future evolution of the system. Based on this prediction, at each time step t the controller selects a sequence of future command inputs or control signals through an on-line optimization procedure, which aims at optimizing a performance, cost or objective function, and enforces fulfilment of the constraints. Only the first sample of the optimal sequence of future command inputs is actually applied to the system at time t. At time t+1, a new sequence is

evaluated to replace the previous one. This on-line re-planning provides the desired feedback control feature. Model Predictive Control can be applied for stabilizing a MLD system to an equilibrium state or to track a desired reference trajectory via feedback control.

5 Model predictive control (MPC) in combination with a Mixed Logical Dynamical (MLD) systems description has been used for modelling and control of processes in the utility automation and process industry. By way of example, a method of scheduling a cement production is described in the article 'Using Model Predictive Control and Hybrid Systems for Optimal Scheduling of Industrial Processes', by E. Gallestey et al., published in AT Automatisierungstechnik, Vol. 51, no. 6, 2003, pp. 10 285-293.

In order to perform the optimization, MPC requires the current state of the plant as a starting point for optimization, or at least a good estimate. In the case of complex plants, the state may be not fully observable due to a limited number of sensors or unfavourably positioned sensors. Here, state estimation is necessary in order to 15 obtain an estimate of the plant state. Moreover, state estimation can be used independently of model predictive control, namely for other control methods or even without control at all (e.g. diagnostics, monitoring, or operator decision support).

20 **SUMMARY OF THE INVENTION**

It is an objective of the invention to promote model-based control of industrial processes or industrial production plants. This objective is achieved by a method of estimating initial states of a system model for an industrial process with a plurality of sub-processes according to claim 1, as well as a device and a computer program for 25 controlling an industrial process according to claim 9 and 10, respectively. Preferred embodiments are evident from the dependent patent claims.

According to the invention, an optimization of an objective function is performed, wherein the objective function includes a difference between an observed, or measured, quantity and an output variable of a Mixed Logical Dynamic (MLD) 30 system model of the industrial process or production plant. The optimization is

performed as a function of state variables of the MLD system model, over a number of time steps in the past, and subject to constraints defined by the MLD system model's dynamics. The optimizing values of the state variables are retained as estimated initial states for subsequently controlling the industrial process or production plant in a model-based manner including the MLD system model. The single MLD system model is a combination or merger of individual MLD subsystem models representing the sub-processes of the industrial process, and may thus be elaborated by a commissioning engineer during a customization step on a plant site, and hence at a comparably late moment during plant execution. The use of a merged MLD system model for both the estimation and subsequent control of industrial processes or production plants simplifies and expedites the set-up of model based control together with accurate estimation of initial states.

An important aspect when targeting a robust behaviour of the state estimation is observability. If there are too few measurements or if there is too much noise or model mismatch to make all states observable, ways have to be found to reduce the degrees of freedom in the model during the estimation procedure. The following preferred embodiments describe respective refinements of a standard Moving Horizon Estimation (MHE).

In a first preferred embodiment, the optimization process is simplified by excluding certain intermediary state variables and reducing the dimension and complexity of the operation correspondingly. In order to complete the estimate of the initial state for the subsequent control involving all state variables, suitable values, possibly less precise, of the excluded variables are simulated or calculated directly from the MLD model.

In a further preferred variant an intermediary sub-process, e.g. having state variables with limited observability, is identified which interconnects or links two peripheral or neighbouring sub-processes, wherein the latter, or their MLD subsystem models respectively, are exclusively interacting with each other via the intermediary sub-process or subsystem model, respectively. By excluding from the optimization the state variables of the latter, the merged MLD system model is split or cut into two independent or disconnected subsystem models representing the peripheral sub-processes, which further simplifies the estimation of the initial states.

In a second preferred embodiment so-called artificial observations are used as a means to make the model more stable during the optimization process. To this end, a regularization term comprising a convex function of a difference between a piecewise linear function of the model outputs or variables and an artificial observation is added to the objective function. Alternatively or in addition thereto, at selected time steps of the optimization, an artificial observation is assigned to the function of the model outputs. This is equivalent to a non-permanent additional hard constraint enforcing an exact solution. The artificial observation is predetermined based on some expert knowledge regarding e.g. a plausible initial state, or based on calculated values from outside the MLD model, e.g. from another simulation or a fuzzy system.

In a third preferred embodiment so-called correction or bias terms are introduced which are capable of estimating a non-zero mean of process or measurement noise. A bias term is implemented as a single state which is constant over the estimation horizon but subject to process noise. A different implementation is a first order filter with a constant as an input. This constant can be zero or some low-pass filtered version of the bias, causing a corresponding decay of the bias term during MPC. By doing so, model mismatch can be compensated and changing process conditions can be accounted for, which is important in order to gain and maintain the predictive power of the model.

In a further variant, the merging of a first and second subsystem comprises a step of eliminating, as far as possible, dependent inputs of the second subsystem that are connected to dependent outputs of the first subsystem. The merged system becomes leaner with less auxiliary variables to be optimized. On the other hand, the remaining dependent inputs, comprising in particular those which close algebraic loops in the merged MLD system, are replaced by additional auxiliary real and/or Boolean variables of the merged MLD system.

Finally, the method is applied to complex industrial processes or production plants such as floatation process or cement kiln that are unique and require a lot of individualisation, due to e.g. plant specific customer requirements or regulations.

BRIEF DESCRIPTION OF THE DRAWINGS:

The subject matter of the invention will be explained in more detail in the following text with reference to preferred exemplary embodiments which are illustrated in the attached drawings, in which:

5 Fig.1 illustrates a flotation system as a first industrial plant;

Fig.2 depicts a clinker production unit as a second industrial plant,

Fig.3 depicts a model of the clinker production unit, and

Fig.4 illustrates a merging of two MLD subsystems into a combined MLD system.

10 DETAILED DESCRIPTION OF THE PREFERRED EMBODIMENTS

Fig.2 shows a specific process configuration of a clinker production unit with a preheater, rotary kiln, and cooler as its main constituents, which may be subdivided into, or merged from, a number of subsystems. In particular, the actual kiln process is divided into five zones or compartments, i.e. preheating, calcining, transition,
15 sintering and cooling. Each of them is modelled by an MLD model suitably configured in order to capture the different characteristics of the different zones. A coarse modelling of the kiln with only three compartments plus an additional preheating compartment at the back and an additional cooler compartment at the front of the kiln proved to be a good compromise reconciling accuracy and
20 computational robustness. Additionally, in parallel to the thermodynamic and mass transport model described by the interconnection of the compartment models, an oxygen model was introduced.

As depicted in Fig.2 manipulated variables or inputs comprise a raw meal feed rate, exhaust gas flow rate, kiln rotational speed, and primary fuel flow rate. The
25 interconnection of the compartment models is described by thermodynamic and mass transport models, which results in states of different zones being connected. Basically, every manipulated variable and every observed variable, or the corresponding sensor, represents a sub-process. In particular, sensor sub-processes

for oxygen level (O₂), Burning Zone temperature (BZT), and preheater cyclone Temperature (BET) were introduced.

Fig.3 depicts the set-up of the model of the clinker production unit of Fig.2 for estimation, with model states being depicted as circles, the subsystems indicated as rectangles, and continuous lines representing direct state connections. The subsystems as indicated by the broken lines define the three independent estimation problems generated by introducing the cuts by means of intermediary states being simulated. This way, the complex far interactions in between the parts which are difficult to understand and prone to instability are eliminated. In the particular kiln example, this technique was applied to the middle compartment, thus essentially dividing the kiln in a front part and a back part.

Fig.4 shows two MLD blocks or subsystems S1 and S2, defined respectively by respective groups of matrices A₁, B_{11...3}, C₁, D_{11...3}, E_{11...5} and A₂, B_{21...3}, C₂, D_{21...3}, E_{21...5} as well as by the vectors of states x₁, x₂, the vectors of inputs u₁, u₂, the vectors of outputs y₁, y₂, the vectors of real auxiliary variables z₁, z₂ and the vectors of Boolean auxiliary variables, δ_1 , δ_2 . The MLD subsystem S₁, S₂ are interconnected as indicated by the arrows joining the two blocks. The goal is to merge S₁ and S₂ in order to obtain one single or combined MLD system S described by the matrices A, B_{1...3}, C, D_{1...3}, and E_{1...5} and the corresponding vectors of states x, inputs u, and outputs y, without the use of auxiliary variables.

The matrices of the combined system S are obtained by creating matrices comprising the corresponding matrices of the subsystems S₁, S₂ along their diagonal as a starting point, subsequently eliminating or exchanging rows and/or columns as explained below. Likewise, the vectors of the combined system S are created by augmenting the vectors of S_i with the corresponding vectors of S₂ as a starting point, and by subsequently eliminating or rearranging their elements if necessary. It is to be noted that the matrices and vectors of the combined system S are uniquely designated and maintain their designation throughout the subsequent operations performed on their rows, columns or elements.

The vectors of states, inputs and outputs can contain both real (denoted with the index r) and Boolean (index b) variables. If this is the case, all the real variables will have to be grouped and placed in the corresponding vector before the Boolean ones. Among the inputs and outputs certain variables are independent of the other MLD block (denoted with the prefix i) and some are dependent (prefix d). Pairs of the dependent variables are represented in Fig. 1 by a common arrow pointing from one MLD block (S1, S2) to the other MLD block (S2, S1).

The treatment of the embodiment according to Figure 2 will be detailed in the following, yet less general configurations with, for example, only one, two or three pairs of dependent variables are also conceivable and can be treated in the framework of the present invention.

The resulting state vector x of the combined MLD block S consists of a composition of all the states of $S1$ and $S2$ and is defined as $x = [x_{r1}, x_{r2}, x_{b1}, x_{b2}]$. Due to the real variables of both systems being placed before the Boolean variables, the matrix A of the combined MLD system S , based on the matrices $A1, A2$ of the subsystems $S1, S2$ as shown above, has to have the rows and columns corresponding to x_{b1} swapped with the rows and columns of x_{r2} . Likewise, the other matrices $B1...3$ involved in the state dynamic of the system S , based on the corresponding matrices $B11...3, B21...3$ of the subsystems $S1, S2$, undergo, in a first step, a corresponding swap of rows. Equally, in a first step a swap of columns is executed on the matrices $C, E4$ of the system S multiplying the resulting state vector x and being based on the corresponding matrices ($C1, E14; C2, E24$) of the subsystems $S1, S2$.

The resulting output vector y of the combined MLD block S consists of a composition of the independent outputs of $S1$ and $S2$ and, taking into account the real before Boolean principle, is defined by $y = [i_{yr1}, i_{yr2}, i_{yb1}, i_{yb2}]$. Again, the matrices involved in the output dynamic ($C, D1...3$) of the system S are based on the corresponding matrices ($C1, D11...3, C2, D21...3$) of the subsystems $S1, S2$. Along the same idea, the rows of these matrices corresponding to i_{yb1} will have to be swapped in a first step with the rows corresponding to i_{yr2} . Additionally, as the dependent outputs are lost, the corresponding rows of the $C, D1...3$ matrices have to be deleted.

The resulting input vector u of the combined MLD block S consists of a composition of the independent inputs of $S1$ and $S2$ and is defined as $u = [iur1, iur2, iub1, iub2]$. Again, the real variables of both systems are being placed before the Boolean variables. The dependent inputs have been dropped. This implies that the input matrix $B1$, in a second step, will undergo a swap between the columns corresponding to $iub1$ and $iur2$, in a third step, will have to have the columns corresponding to the dependent inputs deleted. Likewise, the other input matrices $D1, E1$ of the system S , being based on the matrices $(D11, E11; D21, E21)$ of the subsystems $S1, S2$, will undergo a swap of columns between $iub1$ and $iur2$ and, in a second step, will have the columns corresponding to the dependent inputs ($dur1, dur2, dub1, dub2$) deleted.

In one embodiment of the present invention, variables are eliminated, without the introduction of auxiliary variables. Each dependent input $u1$ to be eliminated is connected to some output $y1$, which is given as a linear combination $y1 = C1x + D11u + D12\delta + D13z$. Since $u1 = y1$, each occurrence of a $u1$ can be straightforwardly replaced by the corresponding linear combination as long as the coefficient of $u1$ in $D1$ is equal to zero.

In other words, suppose the second input of the first MLD is connected to the 5th output of the second MLD, i.e. $u^1_2 = y^2_5$. The variable u^1_2 is removed from the merged MLD. That is, the second column of $B_1/D_1/E_1$ is removed. Any non-zero entry in that second column (i.e. any non-zero value in either of B_1, D_1, E_1) must cause the coefficients of the other variables in the same row to be increased by according multiples of the coefficients of y^2_5 , such that the output of the row remains correct.

This method can only be used if in the column to be removed (the second column of $B_1/D_1/E_1$ in the above example), the entry at the defining row (this was y^2_5 above) is 0, since otherwise the replacement would not be complete. The entry is not zero in case of an *algebraic loop*. If the entry in question is known and different from 1, then the algebraic loop can be resolved by resolving the equation. If the entry in question is 1 (or it is symbolic and hence could be 1), this is not possible. In this case, the “merging with an additional auxiliary variable” procedure is used instead as described below.

The eliminated real dependent inputs will then be substituted by additional real auxiliary variables added to the real auxiliary variables z of the combined system S . Thus the real auxiliary variables of the MLD system include the original auxiliary variables of $S1$ and $S2$ plus the ones introduced by the $S1$ - $S2$ and $S2$ - $S1$ real interconnections. Similarly, the Boolean dependent inputs will be replaced by additional Boolean auxiliary variables added to the Boolean auxiliary variables of the combined system S .

This transformation is obtained or executed by appending the columns deleted from the matrices $B\sim$, $D1$ and $E1$ (observing a change of sign for the latter) to the matrices $B3$, $O3$, and $F3$ if real or to the matrices $B2$, $O2$, and $E2$ if Boolean.

The equations between the dependent inputs and outputs of the two subsystems $S2$ and $S1$ represent the connections between the subsystems. The information contained therein has to be retained and included in the formulation of the combined MLD system S . However, as the dependent variables do not appear in the final formulation, this is not a straightforward task. In the case of the $S1$ - $S2$ connection (short straight arrows in Fig.1), the original expression for the dependent outputs of subsystem $S1$ is comprised in the set of equations:

$$y1 = C1x1 + D11u1 + D12\delta1 + D13z1 \quad (4)$$

As a result of the row-elimination procedure above, these expressions for dyi are absent from the resulting equations for the output variable y of the combined MLD block S .

The merged MLD system S resulting from the procedure outlined above in turn can be considered as a subsystem itself. Via iterated application of the procedure, a complex MLD system representing all relevant technical aspects of an arbitrarily complex industrial installation or process can be generated. Thereby order of merging of the basic' MLD subsystems or "atomic" MLD blocks do not have any impact on the final result and may be chosen at will.

In order to use the MLD system for a model based control procedure an objective function or cost function has to be defined. In the context of the present invention, this is most conveniently done via adding a functional MLD subsystem comprising

exactly one independent scalar output variable representing the objective to be optimized. This functional MLD subsystem is ultimately merged to the complex MLD system representing all relevant technical aspects of the physical process. Thereby, all the outputs of the complex MLD system that are related to costs are regarded as dependent outputs with corresponding dependent inputs of the functional MLD subsystem. There is no restriction on the number of independent inputs u serving as control variables or command inputs of the single-output MLD system S those results from the aforementioned ultimate merger.

We are given an industrial process which can appropriately be modelled as an MLD that is a discrete-time linear or piecewise linear dynamical system with possibly switching behaviour. The MLD model has inputs (manipulated variables), outputs (sensor measurements), states, and possibly auxiliary variables. Mathematically, this reads

$$\begin{aligned} x_{t+1} &= Ax_t + B_1u_t + B_2d_t + B_3z_t + B_5 \\ y_t &= Cx_t + D_1u_t + D_2d_t + D_3z_t + D_5 \\ E_2d_t + E_3z_t &\leq E_1u_t + E_4x_t + E_5 \end{aligned} \quad (\text{Eqns 6a to 6c})$$

Here, t denotes the time index, x contains the state vector, u the input vector, y the output vector, d and z are Boolean and real auxiliary variables, respectively, and the capital letters denote the matrices that define the dynamics of the MLD.

A technique embodying the present invention provides an improved method using the merged MLD model as an input for state estimation, based on the following steps. Fix a number of past time steps, which is known as the estimation horizon. Some of the outputs of the merged MLD model which describes the process are observed for at least a couple of time steps over the estimation horizon (observed history). The goal is to formulate an optimization problem corresponding to moving horizon estimation:

$$J = \sum_{t=-\text{horizon}+1}^0 (y_t - \hat{y}_t)^T W_y^t (y_t - \hat{y}_t) + \sum_{t=-\text{horizon}+2}^0 (x_t^{\text{sim}} - x_t)^T W_x^t (x_t^{\text{sim}} - x_t) \quad (7)$$

Where \hat{y} is the vector of observations, we abbreviate

$$y_t = Cx_t + D_1u_t + D_2d_t + D_3z_t + D_5 \quad \text{and}$$

$$x_t^{sim} = Ax_{t-1} + B_1u_{t-1} + B_2d_{t-1} + B_3z_{t-1} + B_5, \quad (\text{Eqns 8a and 8b})$$

and Wyt and Wxt (t denotes the time step here) contain the state and measurement weight matrices, respectively. Typically, they contain the inverse squares of the state and measurement noises on the diagonal (and 0 off-diagonal); more generally,
 5 the weight matrices can be constructed from any information that is available for the state uncertainties and sensor noise. The weight matrices may depend on the time t . In case of a noise parameter being 0 (observation without noise or fully enforced state dynamics), the corresponding weight would be infinity. These cost functions
 10 are replaced by hard constraints in the optimization problem.

In a technique embodying the present invention the values used to calculate the output of equation 7 are provided by the combined MLD model, arrived at by the technique described above.

The current time is $t=0$ and the usual aim of the estimation is to determine the vector
 15 x_0 . Weights corresponding to non-observed values need to be set to 0, in this case, the corresponding entries of \hat{y} will not matter.

In certain cases (e.g. Booleans are present, and the resulting mixed integer quadratic problem cannot be solved for some reason), the quadratic cost functions above may be replaced by corresponding linear cost functions, where the weights
 20 become the inverse of the state and measurement noises respectively (without squares).

The optimization variables in the optimization problem above are the states x_t , more precisely the sequence of states $\{x_t\}$ over the horizon. However, only the last element of this sequence, x_0 , is of interest because it represents the estimate of the
 25 current plant state.

Although the above formulation of the cost function J above may be altered, e.g. a so-called arrival cost penalizing the gap between the previous and the current state estimate may be added, the fundamental principle is always the same – finding a

reasonable trade-off between the confidence in the quality of the measurements and the confidence in the quality of the process model.

The above-mentioned state-estimation problem is formulated and solved in regular time intervals, e.g. at every time step corresponding to the sampling period of the discrete-time model. This fact, together with a controller that is executed in regular time intervals as well and uses the state estimates as input information, closes the control loop.

The technique embodying one aspect of the present invention uses moving horizon estimation which has a merged MLD model as its input. In such a technique, variables in the system which are known (perfectly observed) can be eliminated from the optimization problem before solving. This can considerably facilitate the optimization, in particular if applied for Boolean variables.

Constraints, e.g. physical bounds on the state variables, can be handled in such a technique with ease. At every time step, the estimator always considers the whole estimation horizon, covering a sufficiently long period of time in the past, so that in certain cases, a dynamical phenomenon in the past can be explained by more recent measurements. The MLD framework allows for easily building up first-principles models, making it straightforward to engineer (i.e. maintain, adapt, and configure) the model and the estimator. The engineer has more freedom when it comes to modelling the process because states can be defined that are not directly measurable, but can only be inferred using state estimation. In summary, our invention is a systematic and powerful way of estimating the dynamical states of a dynamical model.

A method embodying an aspect of the present invention is able to generate optimization problems for estimation in a fully automatic way, using the same MLD model that is (or can be) used for the optimal control. The same method of merging MLDs as described above is used to provide the single MLD model of the system or process for input into the state estimation method.

Given this technology for state estimation, there is a very elegant possibility to estimate adaptive bias terms. An adaptive bias term is a simple single-input single-output MLD

$$\begin{aligned}x_{t+1} &= x_t \\y_t &= x_t\end{aligned}\tag{9a and 9b}$$

which, when used for optimal control, hence just behaves like a constant bias. In state estimation however, the corresponding state noise allows a variation of the bias according to the measurements which are (possibly indirectly) connected to it. A lower state noise will result in a stiffer behaviour of the bias; a higher state noise will render the bias more flexible. It is worthwhile to note that a bias does not have to be associated directly to a particular measurement, but can be placed almost anywhere in the model, e.g. in order to estimate the feed to the process (as necessary in flotation).

One example of a complex industrial process is a cement kiln. If such a process is approximated by a first principles model where the energy balances define the main model dynamics (masses are just fed through the system), it is not sufficient to use only the measured energy states (temperatures) as states of the model. The reason for this is that the heat transfer and chemical reactions, which govern the process, take place within the kiln, where no measurements are available (except for the burning zone temperature, which is derived mainly from the kiln torque). Consequently, the measurements at the end of the kiln must be used in order to derive the energy states within the system. The described MHE technology enables engineers to customize their kiln model very quickly and efficiently to different situations and hardware of the process structures which measurements are available where and how trustworthy are they, what type of the kiln is given (preheater, precalciner, ...), where do the gas flows enter and exit the system, where are which fuels burnt (coal, tyres, alternative fuels,...).

Another complex industrial process is a flotation process for separating minerals from other material, as described above with reference to Figure 1. A supervisory controller can optimize the use of the main manipulated variables: the froth level and the air flow rate of each flotation cell. The accomplishment of the set-points for the froth levels and the air flow rates is the task of the lower-level controllers ("Level control" and "Local air PID controllers") that translate the set-points into openings of the flow valves and air valves, respectively.

The main objective is to perform close level control of the different tanks to set-points determined by either the plant operator or a higher-level controller. As the level set-point may change frequently during operation, the controller must have a good dynamic performance (adequate response time, little overshoot).

5 Another important topic to be dealt with is disturbance rejection. The feed flow to a flotation circuit typically varies considerable in time, depending on the upstream process (either a grinding circuit or another flotation circuit). The variations can be both in quantity and composition (e.g. varying density). A good control strategy must take the feed flow into account, whether it is directly measured or can only be
10 inferred in an indirect way.

Due to time delays, hydrostatic coupling between tanks, recirculating flows, and the mix of slow and fast dynamics (circuit vs. single flotation cell), the dynamics of a flotation circuit are rather intricate. This means that level control performed by a human operator is not a realistic option. Furthermore, conventional control
15 techniques have very limited capabilities in dealing with these dynamical phenomena.

A process such as a flotation circuit may change its properties slowly and gradually in time. For instance, ducts, hoses and pipes may partially clog due to solid deposits and therefore change their flow resistance. Furthermore, equipment (e.g. control
20 valves) may wear off and change its properties. A controller should either be robust enough to preserve performance in spite of such changes and/or to be able to adapt to changing conditions.

Finally, a control (or rather state estimation) strategy should be capable of working in spite of limited instrumentation, in particular a low number of sensors or low-quality
25 measurements.

A level control strategy with poor performance, i.e. one that does not have good tracking and disturbance rejection properties, will have adverse effects on the performance of the supervisory controller and thus lead to suboptimal economical results of the flotation plant.

30 In the following, the general approach behind the model of a flotation cell, the most important component in a flotation circuit, will be described.

$$dV_i / dt = q_{Fi} - q_{Ci} - q_{Ti} \quad (10)$$

Here, V_i is the volume occupied by the pulp in flotation cell i ($i \in \{1, \dots, N\}$, where N is the total number of flotation cells). q_{Fi} , q_{Ci} and q_{Ti} are the feed, concentrate, and tailings volume flows into/out of flotation cell i , respectively.

- 5 In order to express the abovementioned flotation cell model in the MLD framework, two further steps need to be done.

Firstly, the nonlinear model has to be linearized about an operating point. This means that the nonlinear term q_{Ti} must be approximated and linearized. q_{Fi} and q_{Ci} are inputs to the system and are thus already linear.

- 10 Secondly, the continuous-time model must be discretized in time using an approximation such as the Explicit Euler method. Equation (10) is transformed into the following equation:

$$V_i[k+1] = V_i[k] + \Delta t \cdot (q_{Fi}[k] - q_{Ci}[k] - q_{Ti}[k]) \quad (11)$$

- 15 Once all the components used in the flotation circuit have been created, the circuit can be built up from these building blocks. The MLD framework offers everything that is needed in order to define the necessary interconnections. The overall model obtained is again of the MLD type.

- 20 An important feature that has proven successful in advanced process control (APC) of similar processes is the parameterization of the model. The parameters should be adapted automatically and in regular time intervals during operation such as to account for slow process variations.

Each component can be parameterized, where typical parameters are cell volumes, valve coefficients, and the operating point used for linearization. For instance, the operating point is different for different flotation cells and may also vary in time.

- 25 Referring to Figure 1, an example goal is to control the froth layer thickness of the second flotation cell. In order to accomplish this, the following optimization problem is formulated:

$$\begin{aligned} \min_{u, \delta, z} J_{MPC} = \sum_{k=1}^N & [\| y[k]_{SP} - Cx[k] + D1u[k] + D2\delta[k] + D3z[k] \|^2_{Q,2} + \\ & \| u[k+1] - u[k] \|^2_{R,2}] \\ \text{s.t. } E2\delta[k] + E3z[k] & \leq E4x[k] + E1u[k] + E5 \quad \text{for all } k \end{aligned} \quad (12)$$

Here, the vector y_{sp} contains the set-point for the various controlled variables y .

- 5 In order to influence the closed-loop behaviour, the engineer can tune the weighting matrices QMPC and RMPC. For instance, a less aggressive response (less overshoot, but with a longer settling time, i.e. a smaller control bandwidth) is achievable by assigning high gains in the RMPC matrix, thus penalizing the use of control action.
- 10 Furthermore, several control objectives may be traded off against each other, e.g. set-points for different flotation cells in the circuits whose level control precisions have different priorities.

Model-predictive control allows for respecting additional constraints, e.g. lower and upper bounds on the froth layer thickness in flotation cells which have no set-points or constraints that are an integral part of the dynamical model such as

15 interconnecting flows between flotation cells.

The optimization problem (eqn. 10) has to be solved at each sampling period. The result of the optimization is the sequence of control moves $u[k]$ over the control horizon ($k = 0$ to NMPC). However, only the first element, $u[0]$, is of interest because

20 its value is sent to the process as a set-point for the actuators.

Referring again to Figure 1, there are three physical states which should be estimated in order that the MPC calculations can be completed, to do so the following objective function should be optimized at each sampling time:

$$\begin{aligned} \min_{x, \delta, z} J_{MHE} = \sum_{k=-N+1}^0 & [\| x[k] - Ax[k-1] + B1u[k-1] + B2\delta[k-1] + B3z[k-1] \|^2_{Q,2} + \\ & \| y[k] - Cx[k] + D1u[k] + D2\delta[k] + D3z[k] \|^2_{R,2}] \\ \text{s.t. } E2\delta[k] + E3z[k] & \leq E4x[k] + E1u[k] + E5 \quad \text{for all } k \end{aligned} \quad (13)$$

The first component of the cost function in Equation (13) describes the process noise, while the second component is the measurement noise. For exact state evolution and measurements, respectively (i.e. no process or measurement noise, respectively), the corresponding process or measurement noise term is formulated
5 as an equality constraint instead of a part of the cost function.

Thus, the basic principle is to optimize the sequence of states over the estimation horizon in order to find the best trade-off (in a least-squares sense) between the sensor values and the model prediction.

As a result, MHE gives us the sequence of state vectors over the estimation horizon.
10 However, we will only make use of the last element of this sequence, in other terms the best estimate of the current state of the process. This estimate then serves as an initial state for model-predictive control. However, the other elements may be used for diagnostic purposes or in order to perform subsequent parameter estimation.

CLAIMS

1. A method of estimating initial states of a system model for an industrial process with a plurality of sub-processes and implemented by an industrial plant, comprising:

optimizing, by a processor of a computer processing device, as a function of state variables x , an objective function J comprising a difference between observed quantities y and outputs \hat{y} of a merged Mixed Logical Dynamic (MLD) system model for the industrial process, the optimizing being performed over a number of preceding time steps and being subject to constraints defined by dynamics of the merged MLD system model, wherein the merged MLD system model is a combination of MLD subsystem models representing the sub-processes of the industrial process;

retaining, by the processor optimizing values x_0 of the state variables at an ultimate time step as an estimated initial state for control, based on the merged MLD system model, of the industrial process, wherein the state variables comprise an intermediary state variable, and the ultimate time step is an optimized time step at which the optimizing values x_0 of the state variables are estimated to occur;

excluding, by the processor, the intermediary state variable from the optimization; and

simulating, by the processor, a value of the intermediary state variable at the ultimate time step by evaluating the MLD system model, and retaining the simulated value in the estimated initial state x_0 .

2. The method as claimed in claim 1, further comprising:

identifying an intermediary sub-process and interconnecting two peripheral sub-processes, wherein the two MLD sub-system models representing the two peripheral sub-processes are only interacting via the intermediary sub-process; and

designating the state variables of the MLD sub-system representing the intermediary sub-process as intermediary states.

3. The method as claimed in claim 1, further comprising:

adding to the objective function J , at least at one point in time during the optimization, a regularization term including a convex function of a difference between a function of the model outputs \hat{y} and an artificial observation y .

4. The method as claimed in claim 1, further comprising

adding correction terms to the evolution of a process variable that is subject to at least one of changing process conditions and differences between the model and the industrial plant; and

implementing a correction term by one of (i) a single state evolving as a constant and subject to process noise, and (ii) a first-order filter with a constant input and subject to process noise.

5. The method as claimed in claim 1, wherein the merged MLD system involves vectors of states, vectors of inputs, and vectors of outputs, and is a combined system comprising a combination of two arbitrarily interconnected MLD subsystems each involving respective vectors of states, respective vectors of inputs, respective vectors of outputs, respective real auxiliary variables, and respective Boolean auxiliary variables, and being described by respective state and output equations and constraints, and wherein:

the two subsystems are interconnected via dependent pairs formed by a dependent output of one subsystem and a dependent input of the other subsystem;

independent inputs and outputs of the subsystems are not part of the dependent pairs;

a state vector of the combined system is composed of the corresponding states of the subsystems, the input and output vectors of the combined system are composed of the corresponding independent inputs and outputs of the subsystems;

first dependent pairs are eliminated from the merged MLD system by replacing each occurrence of the dependent inputs in the MLD matrices by a linear combination defining the dependent input,

second dependent pairs are replaced by at least one of additional auxiliary real and Boolean variables of the combined system; and

the output equations for the second dependent outputs of each subsystem are converted into additional constraints of the combined system involving the at least one of additional auxiliary real and Boolean variables.

6. The method as claimed in claim 1, further comprising:

adding to the constraints of the optimization problem, at selected time steps of the optimization, an artificial observation y .

7. The method as claimed in any one of claims 1 to 6, wherein the industrial process is a flotation process and the MLD subsystem models include at least one of a tank level, a flow rate, and a valve percentage as a state.

8. The method as claimed in any one of claims 1 to 6, wherein the industrial plant is a cement kiln, and the MLD subsystem models include at least one of a preheater cyclone temperature, oxygen level, burning zone temperature, precalciner temperature, cooler temperature, material flow rate, gas flow rate, a heat input by combustion, and an actuator position as a state.

9. A device for controlling an industrial process implemented by an industrial plant, based on an estimated initial state and a merged Mixed Logical Dynamic (MLD) system model of the industrial process, the merged MLD system model being a combination of MLD subsystem models representing sub-processes of the industrial process, the device comprising a processor configured to:

optimize, as a function of state variables x , an objective function J comprising a difference between observed quantities y and outputs \hat{y} of the merged MLD system model for the industrial process, the optimization being performed over a number of preceding time steps and being subject to constraints defined by dynamics of the merged MLD system model;

retain optimizing values x_0 of the state variables at an ultimate time step as the estimated initial state for control, based on the merged MLD system model of the industrial process, wherein the state variables comprise an intermediary state variable,

the ultimate time step being an optimized time step at which the optimizing values x_0 of the state variables are estimated to occur;

exclude the intermediary state variable from the optimization; and

simulate a value of the intermediary state variable at the ultimate time step by evaluating the MLD system model, and retain the simulated value in the estimated initial state x_0 .

10. The device as claimed in claim 9, the processor further configured to:

identify an intermediary sub-process and interconnecting two peripheral sub-processes, wherein the two MLD sub-system models representing the two peripheral sub-processes are only interacting via the intermediary sub-process; and

designate the state variables of the MLD sub-system representing the intermediary sub-process as intermediary states.

11. The device as claimed in claim 9, the processor further configured to:

add to the objective function J , at least at one point in time during the optimization, a regularization term including a convex function of a difference between a function of the model outputs \hat{y} and an artificial observation y .

12. The device as claimed in claim 9, the processor further configured to:

add correction terms to the evolution of a process variable that is subject to at least one of changing process conditions and differences between the model and the industrial plant; and

implement a correction term by one of (i) a single state evolving as a constant and subject to process noise, and (ii) a first-order filter with a constant input and subject to process noise.

13. The device as claimed in claim 9, wherein the merged MLD system involves vectors of states, vectors of inputs, and vectors of outputs, and is a combined system comprising a combination of two arbitrarily interconnected MLD subsystems each involving respective vectors of states, respective vectors of inputs, respective

vectors of outputs, respective real auxiliary variables, and respective Boolean auxiliary variables, and being described by respective state and output equations and constraints, and wherein:

the two subsystems are interconnected via dependent pairs formed by a dependent output of one subsystem and a dependent input of the other subsystem;

independent inputs and outputs of the subsystems are not part of the dependent pairs;

a state vector of the combined system is composed of the corresponding states of the subsystems, the input and output vectors of the combined system are composed of the corresponding independent inputs and outputs of the subsystems;

first dependent pairs are eliminated from the merged MLD system by replacing each occurrence of the dependent inputs in the MLD matrices by a linear combination defining the dependent input,

second dependent pairs are replaced by at least one of additional auxiliary real and Boolean variables of the combined system; and

the output equations for the second dependent outputs of each subsystem are converted into additional constraints of the combined system involving the at least one of additional auxiliary real and Boolean variables.

14. The device as claimed in claim 9, the processor further configured to:

add to the constraints of the optimization problem, at selected time steps of the optimization, an artificial observation y .

15. The device as claimed in any one of claims 9 to 14, wherein the industrial process is a flotation process and the MLD subsystem models include at least one of a tank level, a flow rate, and a valve percentage as a state.

16. The device as claimed in any one of claims 9 to 14, wherein the industrial plant is a cement kiln, and the MLD subsystem models include at least one of a preheater cyclone temperature, oxygen level, burning zone temperature, precalciner

temperature, cooler temperature, material flow rate, gas flow rate, a heat input by combustion, and an actuator position as a state.

17. A non-transitory computer-readable recording medium having program instructions recorded thereon that causes a processor of a computer processing device to estimate initial states of a system model for an industrial process with a plurality of sub-processes and implemented by an industrial plant, the program instructions causing the processor to execute operations, comprising:

optimizing, as a function of state variables x , an objective function J including a difference between observed quantities y and outputs \hat{y} of a merged Mixed Logical Dynamic (MLD) system model for the industrial process, the optimizing being performed over a number of preceding time steps and being subject to constraints defined by dynamics of the merged MLD system model, wherein the merged MLD system model is a combination of MLD subsystem models representing the sub-processes of the industrial process;

retaining optimizing values x_0 of the state variables at a time step as an estimated initial state for control, based on the merged MLD system model, of the industrial process, wherein the state variables include an intermediary state variable, and the time step is an optimized time step at which the optimizing values x_0 of the state variables are estimated to occur;

excluding the intermediary state variable from the optimization; and

simulating a value of the intermediary state variable at the time step by evaluating the MLD system model, and retaining the simulated value in the estimated initial state x_0 .

18. The recording medium as claimed in claim 17, the operations further comprising:

identifying an intermediary sub-process and interconnecting two peripheral sub-processes, wherein the two MLD sub-system models representing the two peripheral sub-processes are only interacting via the intermediary sub-process; and

designating the state variables of the MLD sub-system representing the intermediary sub-process as intermediary states.

19. The recording medium as claimed in claim 17, the operations further comprising:

adding to the objective function J , at least at one point in time during the optimization, a regularization term including a convex function of a difference between a function of the model outputs \hat{y} and an artificial observation y .

20. The recording medium as claimed in claim 17, the operations further comprising:

adding correction terms to the evolution of a process variable that is subject to at least one of changing process conditions and differences between the model and the industrial plant; and

implementing a correction term by one of (i) a single state evolving as a constant and subject to process noise, and (ii) a first-order filter with a constant input and subject to process noise.

21. The recording medium as claimed in claim 17, wherein the merged MLD system involves vectors of states, vectors of inputs, and vectors of outputs, and is a combined system comprising a combination of two arbitrarily interconnected MLD subsystems each involving respective vectors of states, respective vectors of inputs, respective vectors of outputs, respective real auxiliary variables, and respective Boolean auxiliary variables, and being described by respective state and output equations and constraints, and wherein:

the two subsystems are interconnected via dependent pairs formed by a dependent output of one subsystem and a dependent input of the other subsystem;

independent inputs and outputs of the subsystems are not part of the dependent pairs;

a state vector of the combined system is composed of the corresponding states of the subsystems, the input and output vectors of the combined system are composed of the corresponding independent inputs and outputs of the subsystems;

first dependent pairs are eliminated from the merged MLD system by replacing each occurrence of the dependent inputs in the MLD matrices by a linear combination defining the dependent input,

second dependent pairs are replaced by at least one of additional auxiliary real and Boolean variables of the combined system; and

the output equations for the second dependent outputs of each subsystem are converted into additional constraints of the combined system involving the at least one of additional auxiliary real and Boolean variables.

22. The recording medium as claimed in claim 17, the operations further comprising:

adding to the constraints of the optimization problem, at selected time steps of the optimization, an artificial observation y .

23. The recording medium as claimed in any one of claims 17 to 22, wherein the industrial process is a flotation process and the MLD subsystem models include at least one of a tank level, a flow rate, and a valve percentage as a state.

24. The recording medium as claimed in any one of claims 17 to 22, wherein the industrial plant is a cement kiln, and the MLD subsystem models include at least one of a preheater cyclone temperature, oxygen level, burning zone temperature, precalciner temperature, cooler temperature, material flow rate, gas flow rate, a heat input by combustion, and an actuator position as a state.

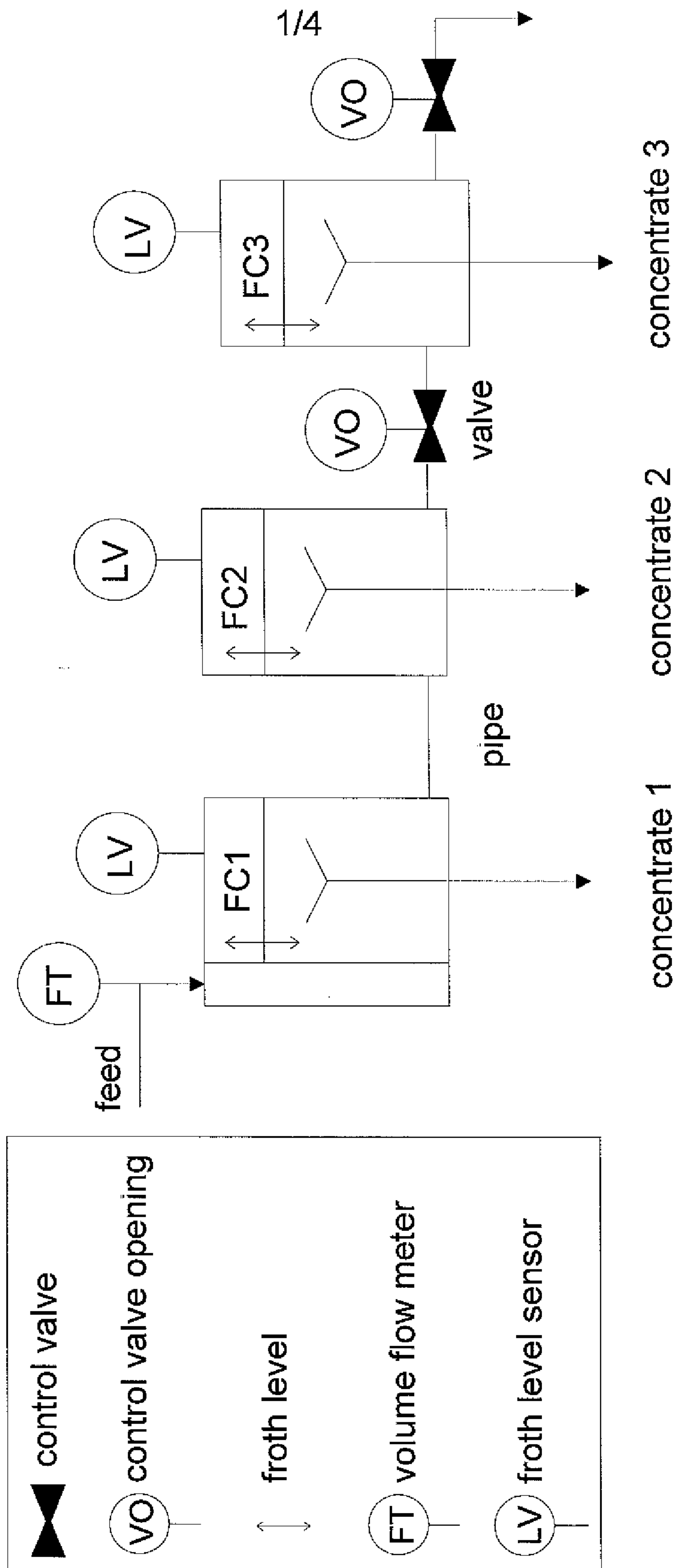

Fig. 1

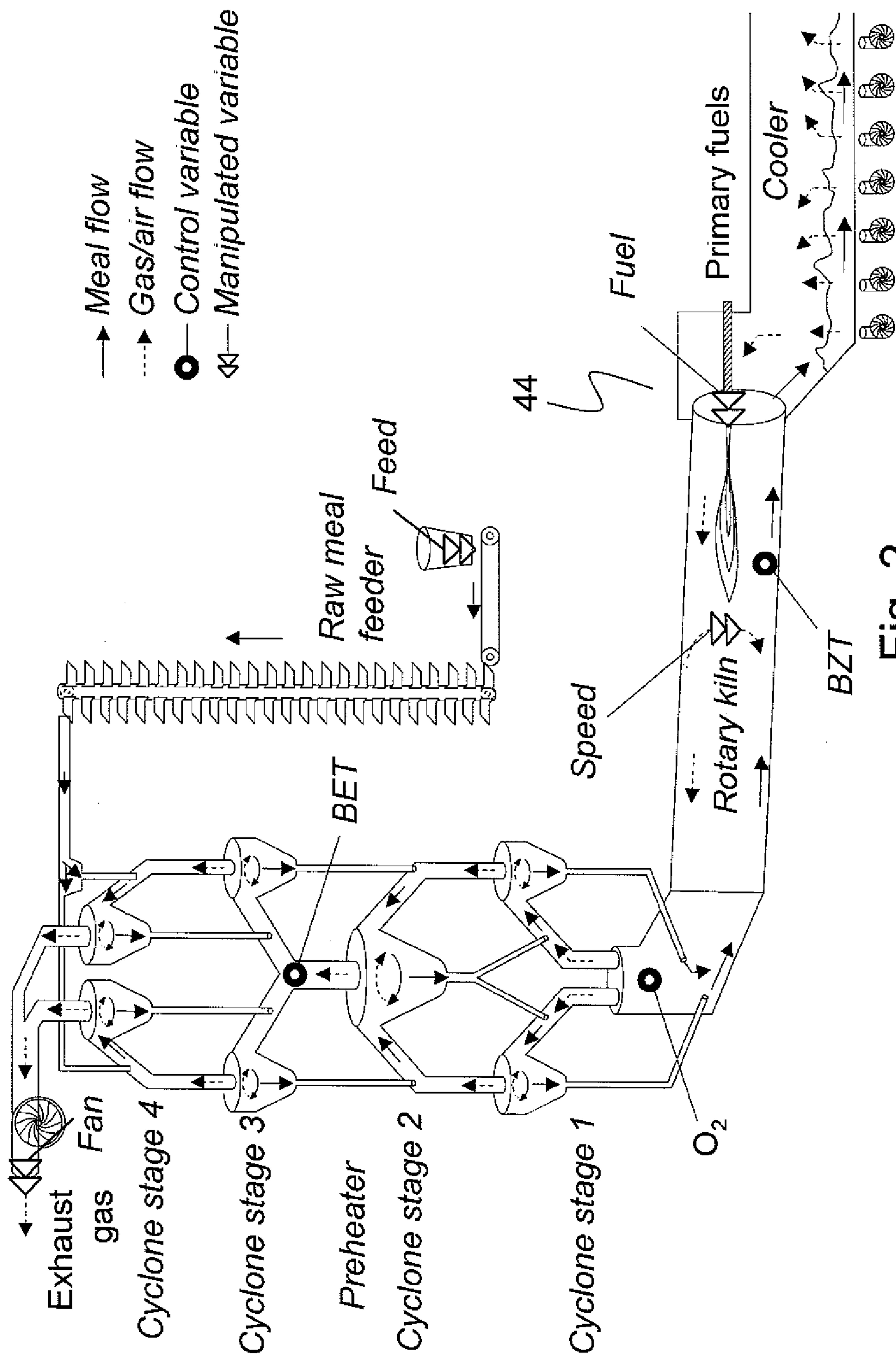
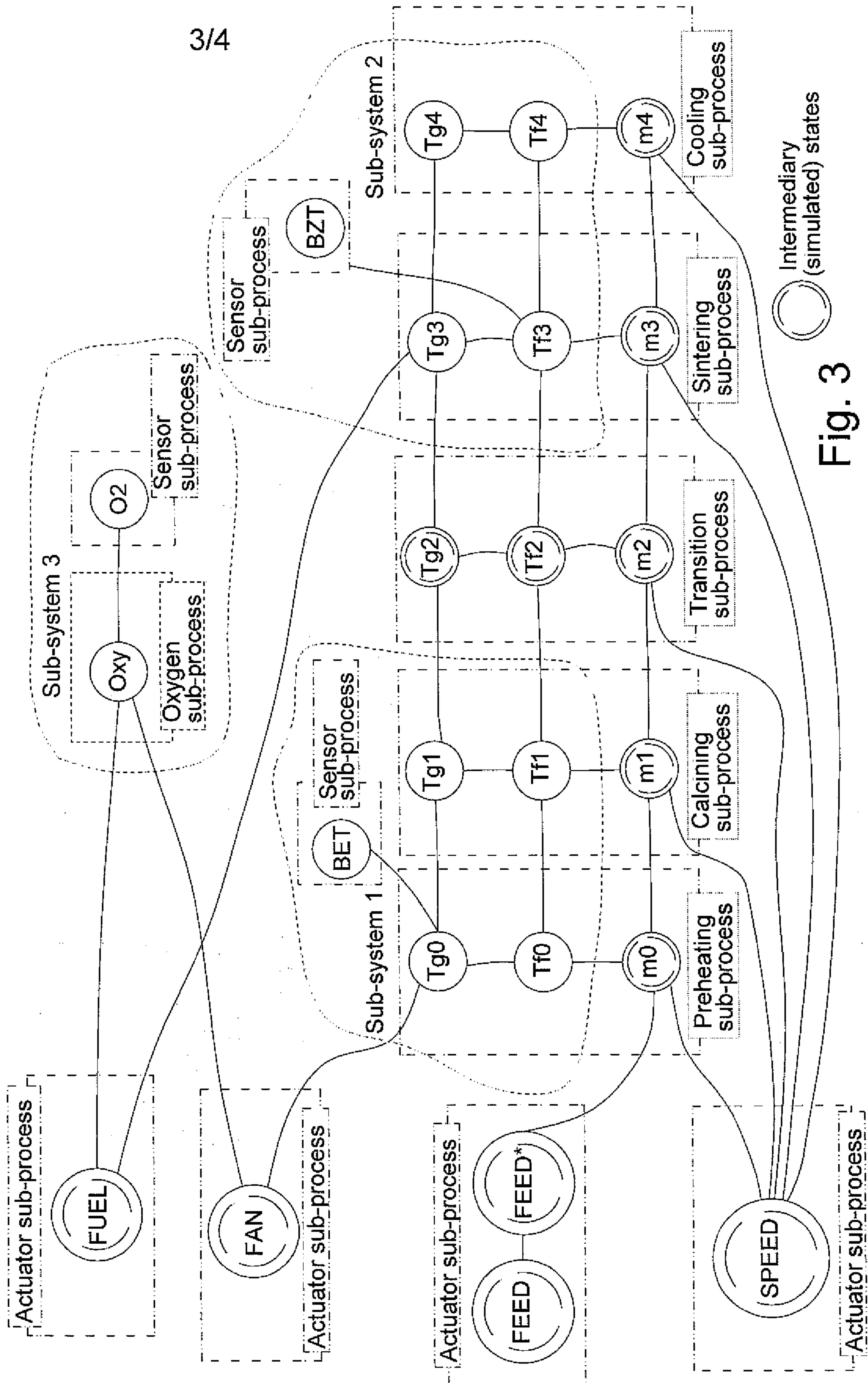

Fig. 2



4/4

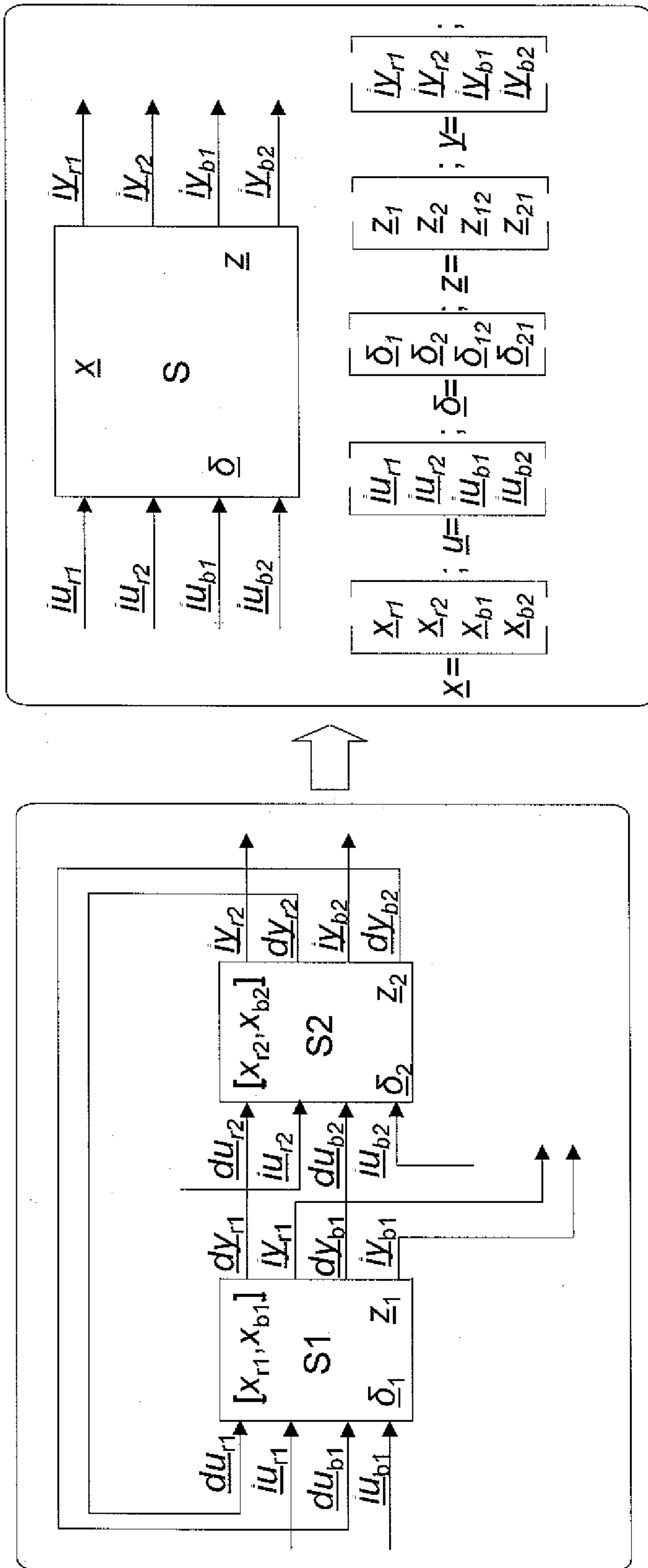

Fig. 4

