

June 15, 1965

K. M. NODOLF

3,188,784

ELECTROSTATIC PRECIPITATORS

Filed Dec. 7, 1962

2 Sheets-Sheet 1

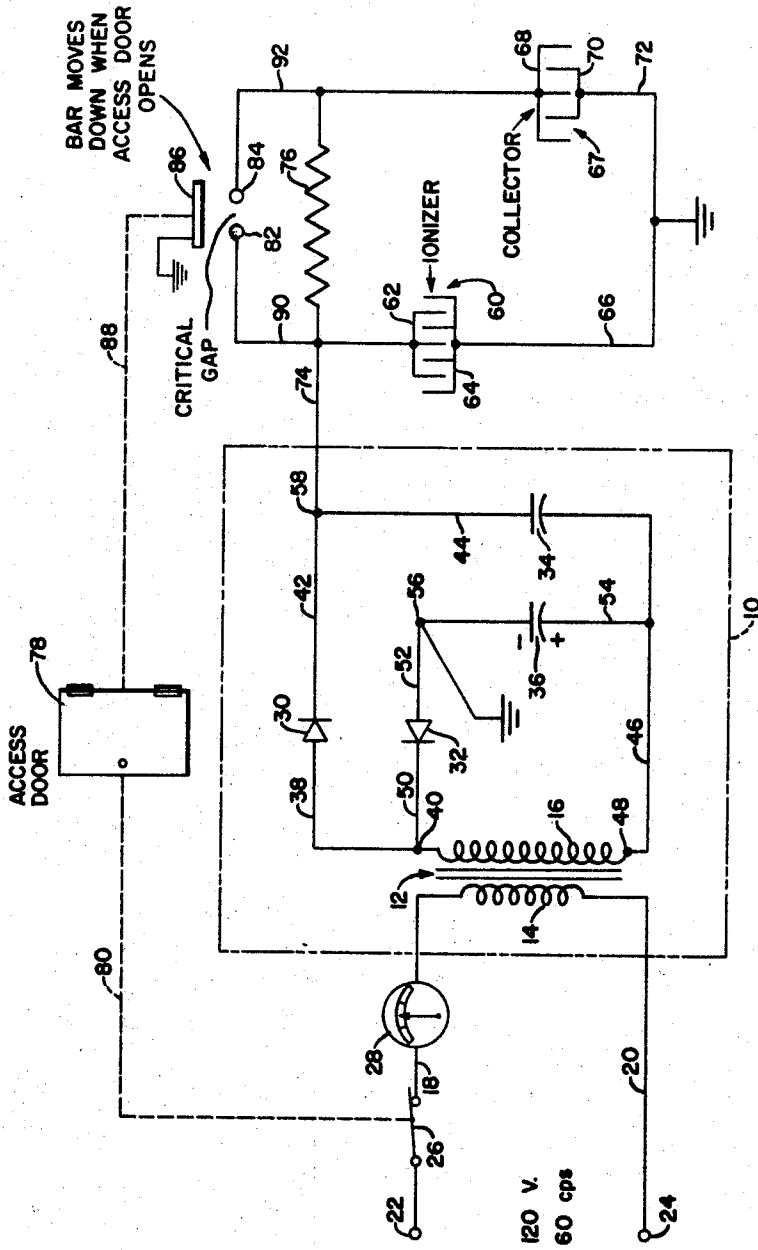

INVENTOR.

KEITH M. NODOLF

BY *Frederick E. Lang*

ATTORNEY

June 15, 1965

K. M. NODOLF

3,188,784

ELECTROSTATIC PRECIPITATORS

Filed Dec. 7, 1962

2 Sheets-Sheet 2

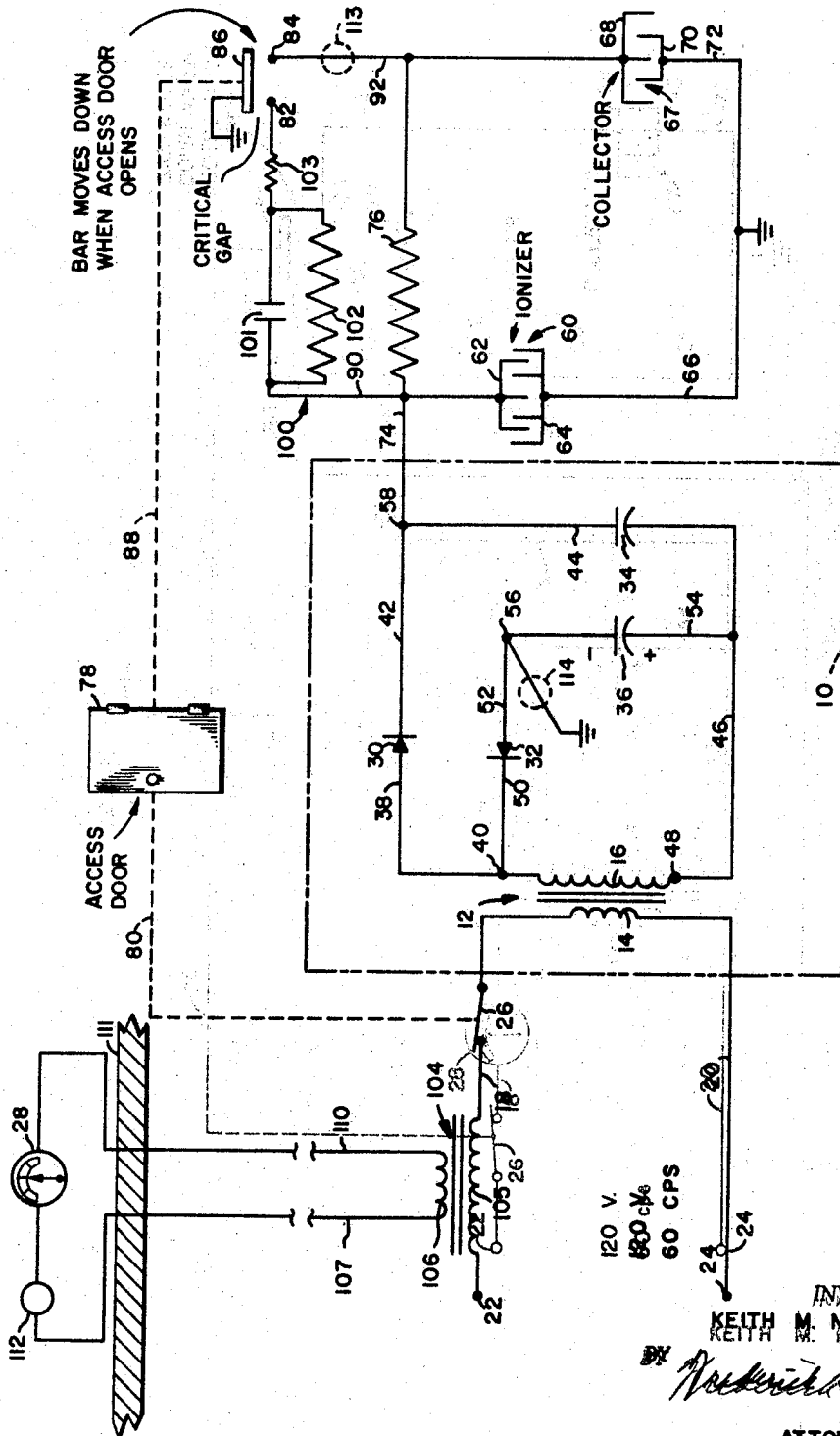

120 V.  
 600 c/μ  
 60 CPS

INVENTOR  
 KEITH M. NODOLF  
 KEITH M. NODOLF  
*Keith M. Nodolf*  
 ATTORNEY

1

3,188,784

**ELECTROSTATIC PRECIPITATORS**

Keith M. Nodolf, Bloomington, Minn., assignor to Honeywell Inc., a corporation of Delaware  
 Filed Dec. 7, 1962, Ser. No. 243,167  
 11 Claims. (Cl. 55-105)

This application is a continuation-in-part of application Serial Number 47,640 which was filed on August 5, 1960, now forfeited.

This invention relates generally to electrostatic air purifying apparatus, and more specifically to an improved means whereby the operating conditions of the unit may be monitored at a remote location.

In electrostatic dust precipitating units which are designed for use in residential dwellings, it is common practice to locate the precipitating device in the cold air return of the building's forced air heating system. In most homes, the heating ducts and furnace are located in the basement. It is therefore desirable that some means be provided in the living area whereby the home owner can observe the condition of the filter. When the monitoring means indicates faulty operation of the electrostatic filter due to excessive dirt accumulation in the filter or some other cause, the occupant is advised of this fact and can take steps to correct this situation. By placing the indicating means in the upstairs living area, there is no need for him to make special trips into the basement to actually observe the condition of the system.

In order to keep the cost of the electronic filtering system low, the same power supply is conveniently used to energize both the gas ionizing section of the system and its particle collecting section. The conventional power supply for an electrostatic filtering system is generally comprised of a step-up transformer and a voltage multiplying device for converting alternating current at normal line voltage to direct current at a relatively high voltage. The ionizing electrodes and one set of collecting plates are then generally connected in parallel and energized by the output from the voltage multiplying device. With the ionizing electrodes and the collecting plates connected in parallel, the same voltage appears across each. For proper ionization of the gas particles, it is necessary that a high potential difference exists between the ionizer electrodes and their associated ground plates. When this voltage is applied between the positive and the grounded collector plates, a problem arises due to excessive arcing between the collector plates. In fact, unless some steps are taken to eliminate or reduce this problem, a sustained arc may be developed which would damage the system. To obviate this problem, it has been found convenient to connect current limiting means such as a resistor of relatively high ohmic value in series between the high voltage ionizing electrodes and the positive potential high voltage collecting plates. This resistor limits the current flow in the collector section and thereby reduces the deleterious effects caused by arcing.

When the remote indicating means is located in the living area, it becomes desirable to connect the device in the low voltage or primary side of the power supply. By doing so, the need for running wires at a high voltage into the living area is eliminated. However, when current limiting means are utilized between the ionizing and collecting sections to prevent arcing, it is found that the occurrence of a fault in the collecting section of the elec-

2

trostatic filter unit does not load down the power supply sufficiently to give a measurable indication of this fault. For example, dirt and lint may build up on the collecting plates to a sufficient depth to cause a shorting of the collector plates without causing an indication of this condition to be given at the remote location. In order to solve this problem, I provide means for introducing a substantial load on the power supply, only, in the event of a short circuit, or reduction in voltage as by excessive leakage current in the collecting section which, in turn, causes a measurable increase in the current flowing in the primary winding of the power supply transformer.

It is accordingly an object of the present invention to provide an improved monitoring arrangement for an electrostatic gas purifying system.

Another object of my invention is to provide a novel arrangement whereby a remote indication of faulty operation of an electrostatic filter unit may be obtained.

Still another object of my invention is to provide means whereby a remote indication of faulty operation can be obtained in an electrostatic gas purifying system of the type incorporating arc preventing means.

Further features, advantages, arrangements, and objects of my invention will be apparent from the following description thereof, which should be taken in conjunction with the drawing wherein:

FIGURE 1 discloses, in schematic form, a power supply circuit for an electrostatic precipitator which illustrates my invention.

FIGURE 2 discloses, in schematic form, a somewhat modified power supply circuit wherein certain components have been added to improve the operation of the system.

Referring now to FIGURE 1, the power supply for the electrostatic precipitator is shown as being enclosed in a casing 10. The power supply includes a step-up transformer 12 having a primary winding 14 and a secondary winding 16. Conductors 18 and 20 connect the primary winding 14 to a pair of terminals 22 and 24 which, in turn, are adapted to be connected to a source of normal line voltage. Connected into conductor 18 in series with the primary winding 14 is a door interlock switch 26 and a fault indicating means 28. In the preferred embodiment of this invention the fault indicating means 28 may be an alternating current ammeter properly calibrated and labeled so as to inform the occupant at all times of the condition of operation of the filtering system. The indicating means 28, being on the low voltage or primary side of the power supply 10, may conveniently be located in the living area of the residence in which the system is used whereas the power supply itself may be conveniently located in close proximity to the forced air heating system used which is usually located in a basement area.

A pair of rectifier diodes 30 and 32 and a pair of capacitors 34 and 36 are connected in a conventional manner with the secondary winding 16 of the power supply transformer 12 to provide voltage rectification and multiplication. More specifically, a conductor 38 connects a first terminal 40 of the secondary winding 16 to the anode of the diode rectifier 30. The cathode of this diode is connected by means of conductors 42 and 44 to the capacitor 34. A conductor 46 connects the other side of capacitor 34 to the terminal 48 of secondary winding 16. Similarly, the cathode of the diode 32 is connected by means of a conductor 50 to the transformer secondary winding terminal 40. The anode of the diode 32 is connected by

3

means of a conductor 52 to one side of the capacitor 36. The other side of capacitor 36 is connected by means of conductors 54 and 46 to the secondary winding terminal 48. The conductor 52 is grounded at junction 56.

During the half cycle of the applied voltage which makes terminal 40 of the secondary winding 16 positive, current flows in the forward direction to the diode 30 so as to charge the capacitor 34 to approximately the peak voltage induced in the secondary winding 16 with the polarity as indicated. At this time diode 32 is reverse biased so that the capacitor 36 does not charge up. During the next half cycle of the applied voltage, however, junction 40 becomes negative so as to reverse bias the diode 30 and to forward bias diode 32. With diode 32 conducting, capacitor 36 also charges up to the peak value of the voltage induced in the secondary winding 16 with the polarity indicated. The potential appearing between the grounded junction 56 and the output terminal 58 of the power supply is therefore approximately two times the peak voltage induced in the secondary winding 16.

As is well known in the art, a precipitator of the type to which my invention relates comprises an ionizing section for ionizing or charging the dust particles in the air flow, and a precipitating section for precipitating the ionized or charged dust upon dust-precipitating or dust-collecting means.

The ionizing section of the electrostatic filter is indicated generally by the numeral 60 and includes one or more ionizing electrodes 62 and one or more plates 64 which are connected to ground by means of a conductor 66. The particle collection section of the electrostatic filter is indicated generally by the numeral 67. The collecting section includes a first set of plates 68 and a second set of plates 70 which are spaced apart from one another in any of a number of well known ways. One manner of construction of the ionizing and collecting sections of an electronic precipitator is shown in my United States Patent Number 3,028,715. The collector plates 70 are connected by means of a conductor 72 to ground potential. A conductor 74 connects the output terminal 58 of the power supply to the ionizing electrodes 62. The output terminal 58 is also connected through conductor 74 and the current limiting means 76 to the collecting plates 68.

In a working embodiment of the apparatus incorporating my invention the spacing between the positive collecting plates 68 and the grounded collecting plates 70 is relatively small. As a result, there is a tendency for the air separating these plates to break down and to cause very severe and continuous arcing in the collector unless steps are taken to reduce or eliminate this effect. I have found that the most effective way of reducing the tendency for arc over in the collector is to include the current limiting resistor 76 in the high voltage line between the ionizer electrode 62 and the positive collector plates 68. The tendency to arc between the positive plates 68 and the ground plates 70 is accompanied with an increase in current flowing through the current limiting resistor 76. This increase in current results in an increase in the voltage drop across this resistor so as to reduce the potential difference between the positive plates 68 and the ground plates 70. By reducing this potential difference the tendency to arc is also reduced.

In electrostatic precipitators, it is desirable to be able to remove the particle collecting section 67 from the cabinet or heating ducts so that it may be washed or otherwise cleaned. To do so necessitates opening of an access door, indicated generally by the numeral 78, which is provided in the cabinet. The access door interlock switch is mechanically coupled by a linkage 80 to the access door 78 such that when it is opened the primary winding of the transformer is deenergized. Because the ionizer section 60 and the collecting section 67 act as capacitors, it would still be hazardous for the home owner to remove the collecting section 67 act as capacitors, it would still be hazardous for the home owner to remove the collecting sec-

4

tion from the filtering unit before the charge is removed from these sections. I therefore provide a pair of shorting terminals 82 and 84 which are arranged to cooperate with a grounded shorting bar 86 activated through linkage 88 by the access door 78. The terminal 82 is connected by means of a conductor 90 to the ionizing electrode 62 whereas the terminal 84 is connected by means of a conductor 92 to the positive collecting plates. When the door is open, the grounded shorting bar 86 is made to bridge the terminals 82 and 84 which grounds the high voltage side of the ionizer and collector. As can be seen from the circuit diagram, the shorting bar also causes the capacitors 34 and 36 to be discharged when it is made to bridge terminals 82 and 84.

If the current sensing means located in the primary circuit of the power supply is an ammeter, which is rated to give a normal reading in the center of its scale when the electrostatic filtering system is working properly, several system faults can be detected. For example, a shorted or open ionizer, a shorted or open rectifier, or a shorted or open filter capacitor causes a lower than normal meter reading. An arcing ionizer can readily be detected because this condition causes the meter reading to fluctuate over a wide range. However, when current limiting means are employed in the system to prevent arcing in the collector, an abnormally low impedance such as a short circuit in the collecting section will not cause a perceptible deflection of the meter. Since a short or excessive leakage current caused by a large accumulation of dirt in the collecting section is a common fault, it is desirable that the home owner be advised of this condition so that he can correct the fault by washing the accumulation of dirt from the collecting plates. In order to cause a shorting of the collecting plates or excessive leakage currents to load down the power supply by an amount sufficient to produce a perceptible deflection of the meter 28, I position the two terminals 82 and 84 sufficiently close to one another so that when the current flowing through the current limiting resistor 76 increases because of the short in the collecting section or excessive leakage current in the collector, a sufficiently high potential difference is created between the terminals 82 and 84 to cause voltage breakdown of the medium separating these two terminals. When the breakdown voltage of the medium separating the contacts 82 and 84 is exceeded, an arc is developed between the two contacts which, in effect, provides a low resistance path around the current limiting resistor 76. The load on the power supply is therefore substantially increased causing an increase in the amount of current flowing from the lines through the meter and the primary winding 14 of the power supply transformer 12.

Thus it can be seen that I have provided an arrangement whereby a current sensing device normally used to monitor the system operation can also be used to indicate a shorted collecting section, all this being done without requiring any additional apparatus or equipment.

FIGURE 2 discloses a somewhat modified power supply circuit having certain additional components which are effective to improve the operation of the system and the circuit shown in FIGURE 2 may thus be considered as an improvement over the circuit shown in FIGURE 1 and previously described. While the circuit disclosed in FIGURE 1 functions as described above to render the meter 28 sensitive to an unusually low impedance condition in the collector 67, it has been found that continued arcing between the terminals 82 and 84 over an extended period of time and the resulting relatively high current flow and severe transients through the power supply, has had a destructive effect upon the capacitors 34 and 36. This problem can, of course, be overcome by the use of very high quality capacitors which are able to withstand these conditions. However such capacitors are quite expensive and would increase appreciably the cost of the system.

To overcome this problem and to thus allow the use of

less expensive capacitors in the power supply, an arc quenching impedance means generally designated by the numeral 100 has been connected in conductor 90 between terminal 82 and the positive plates 62 of the ionizer 60. Arc quenching means 100 comprises a relatively small capacitor 101 and a relatively high ohmic value resistor 102 connected in parallel therewith. A relatively small resistor 103 is connected in series with the parallel combination of capacitor 101 and resistor 102 to reduce the current flow through capacitor 101. The operation of the circuit with the arc quenching means 100 added thereto will be described hereinafter.

Additional modifications to the circuit shown in FIGURE 1 have also been made in FIGURE 2, on the low voltage or primary side of transformer 12. In FIGURE 1 the ammeter 28 has been shown connected directly in series with the 120 volt line power source. In many applications, however, it is desired that low voltage wiring be used between the basement where the air cleaner would normally be located and the upstairs living area where the ammeter 28 is normally located. This can readily be accomplished as shown in FIGURE 2 by providing a step-down transformer 104 having a primary winding 105 connected in series with primary 14 of transformer 12. Secondary coil 106 is connected to conductors 107 and 110 which extend upward through the floor, a section of which is shown diagrammatically at 111, to meter 28 in the living area of the house. Transformer 104 is effective to reduce the voltage supplied to meter 28 from line voltage to a considerably lower voltage. An indicating light 112 may also be connected into the low voltage circuit of transformer 104 in series with meter 28. Indicating light 112, if used, is preferably not responsive to the normal flow of current through the low voltage circuit of transformer 104, but is responsive only to the increased flow which occurs therethrough during a period when arcing occurs between terminals 82 and 84.

In addition to the indicating means such as light 112 and meter 28 previously described, it may be desirable to add some type of indicating means such as lights in the area where the air cleaner is situated. This may be accomplished by adding indicating means responsive to the increased flow of current when arcing occurs between terminals 82 and 84. Such indicating means has been shown in dotted form as an indicating light 113 which may be connected in conductor 92 between terminal 84 and positive plates 68 of the collector 67. An additional indicating light 114 has been shown in dotted form located between terminal 56 in the power supply and ground. It will be obvious that indicating devices 113 and 114, if used, need not be positioned within the circuit exactly as described above, but might be located any place in the circuit where they will be effective to indicate the increased current flow through the system which occurs when arcing takes place between terminals 82 and 84.

The operation of the system disclosed in FIGURE 2 is substantially the same as that described in connection with FIGURE 1 with the exception of the function of arc quenching impedance means 100. In the circuit shown in FIGURE 1, once arcing had begun between terminals 82 and 84 as a result of an abnormally low impedance condition in the collector 67, this arcing would continue as long as the voltage was supplied or until the abnormal condition therein was corrected. With the system shown in FIGURE 2, an abnormally low impedance condition in the collector 67 will again result in a large potential difference across the current limiting resistor 76. This large potential difference will also occur across the critically spaced terminals 82 and 84. This results in a breakdown of the air between terminals 82 and 84 and an arc therebetween. Current flows through resistor 103 and across the gap between the terminals and capacitor 101 is charged. Resistor 103 is merely effective to reduce the intensity of the arc. This current flow decreases as the charge on capacitor 101 increases and when capacitor 101

is substantially charged, the current flow drops to a level so that the arc is extinguished. The charge on capacitor 101 is then gradually bled off through by-pass resistor 102. When capacitor 101 is sufficiently discharged, the potential difference across terminals 82 and 84 will again initiate an arc thereacross and capacitor 101 is again charged. This action is repetitive and capacitor 101 will be alternately charged through resistor 103 and then discharged through resistor 102 as long as voltage is supplied or until the malfunction in the collector is corrected. It can thus be seen that arc quenching means 100 is effective to periodically terminate the arcing between terminals 82 and 84. Thus the transient currents in the power supply are also somewhat limited and are periodically interrupted and damage to capacitors 34 and 36 is thus prevented.

When current flow occurs between the terminals 82 and 84, transformer 12 is loaded so that there is additional current flow in the primary side thereof. Therefore additional current flow also occurs in the primary side of transformer 104 and is indicated by the indicating means in the living area. The periodic quenching of the arc between terminals 82 and 84 will result in an oscillation of the indicator in ammeter 28 and in periodic flashing of the indicator light 112. It will be obvious that the indicating light 112 and ammeter 28 may be used together or either of them may be used independently of the other if so desired. While the malfunction in the collector 67 of the electrostatic precipitator is indicated in the living area of the dwelling by the indicating light 112 and ammeter 28, a malfunction may also be indicated at the precipitator by the lights 113 and 114. When arcing occurs across the terminals 82 and 84, the flow of current between terminal 84 and ground will be effective to periodically flash the light shown at 113. Increased current will also flow through the power supply and may be indicated by the light 114 connected between the terminal 56 and ground.

It will be seen that the addition of arc quenching means 100 in the conductor 90 between terminal 82 and the positive electrodes of the ionizer will not materially effect the operation of shorting bar 86 when access door 78 is open. It will be noted that due to the addition of the relatively large resistance 102 to the circuit, the time required to discharge the capacitors 34 and 36 and also the ionizer 60 may be somewhat increased. However the size of capacitors 34 and 36 and the ohmic value of resistor 102 required for proper operation of the system is such that the time required to discharge the capacitors, once the shorting bar 86 contacts terminals 82 and 84, is sufficiently short to eliminate danger to the home owner upon opening of the access door.

From the foregoing it will be seen that I have provided means rendering the current sensing device normally used to indicate malfunctions in the power supply or ionizing sections of an electrostatic precipitator also responsive to malfunctions in the collector section. This has been accomplished by the use of a system which is simple and efficient and which requires a minimum number of additional components to be added to the normal precipitator circuit.

While the invention is not to be limited to the use of resistors and capacitors of any particular value, the following values were employed in one particular embodiment:

Capacitors 34 and 36	-----	.05 mf.
Resistor 76	-----	30 megohms.
Capacitor 101	-----	.05 mf.
Resistor 102	-----	30 megohms.
Resistor 103	-----	1000 ohms.

Having thus described my invention in rather full detail, it will be understood that these details need not be strictly adhered to but that various changes and modifications may suggest themselves to one skilled in the art,

all falling within the scope of the invention as defined by the appended claims.

What I claim is:

1. In an electronic gas purifying system, the combination comprising: a housing for the purifying system and including an access door; power supply means having low voltage input means, a high voltage output terminal, and a grounded terminal; gas particle ionizing means having first and second sets of electrodes interleaved and spaced apart from one another; gas particle collecting means having first and second sets of plates interleaved and spaced apart from one another; means connecting said first set of electrodes in common with the high voltage terminal of said power supply means; means connecting said second set of electrodes in common with the grounded terminal of said power supply; current limiting means; means including said current limiting means connecting said first set of plates to said high voltage terminal of said power supply means, means connecting said second set of plates in common with said grounded terminal of said power supply; first and second shorting terminal means; means connecting said first terminal means in common with said first set of electrodes; means connecting said second terminal means in common with said first set of plates; a grounded shorting bar; means operable by said access door to bridge said shorting bar across said first and second terminal means upon the opening of the access door, said terminal means being spaced from one another such that a short circuit between said first and second set of plates causes voltage breakdown and currents flow between said first and second terminal means; and current measuring means connected in the low voltage circuit of said power supply for indicating the presence of said short circuit between said first and second set of plates.

2. In an electronic gas purifying system, means for indicating a fault in the collecting section thereof comprising: power supply means including transformer means having primary winding means adapted to be connected to a source of relatively low alternating current voltage, secondary winding means; voltage multiplying means having input and output terminals, said input terminals being connected to said secondary winding means for producing a relatively high direct current potential at said output terminals; current limiting means; gas particle collecting means; means including said current limiting means connecting said collecting means to the output terminals of said voltage multiplying means; first and second shorting terminal means; means connecting said first and second terminal means across said current limiting means; said terminal means being spaced from one another such that an abnormally low impedance condition in said collecting means causes voltage breakdown across said shorting terminal means; and current measuring means connected in the primary circuit of said transformer means responsive to the change in primary current occurring when said voltage breakdown condition exists.

3. In an electronic gas purifying system in which it is desirable to have remote and positive indications of system operation, the combination comprising: power supply means for converting low alternating current voltage to high direct current voltage, said power supply means having low voltage input terminals and high voltage output terminals, particle ionizing means, circuit means connecting said ionizing means to said output terminals, particle collecting means, current limiting impedance means, means including said current limiting means connecting said particle collecting means to said output terminals, spaced shorting terminal means connected in parallel with said current limiting means and spaced from one another so that the current flow through said limiting means caused by an abnormally low impedance in said collecting means causes a potential difference between said terminal means sufficient to cause voltage breakdown between said terminal means, said voltage breakdown cre-

ating a current surge on said power supply means, and current sensing means connected in the low voltage side of said power supply to indicate said voltage breakdown across said terminal means, said current sensing means being responsive to abnormally low impedances in said collecting means which create positive current surges indicative of the operating condition of the electronic gas purifying system.

4. In an abnormal operating condition indicating circuit for a gas cleaning apparatus: collecting means for collecting foreign particles from gas flowing therethrough, said collecting means normally having a relatively high electrical impedance, a power supply having a high voltage output circuit, current sensing means, circuit means including said current sensing means for connecting said power supply to a source of power, a current limiting resistance, means connecting said high voltage output circuit through said resistance to said collecting means, said resistance limiting the current drain on said power supply to a predetermined value upon the presence of an abnormal impedance condition existing in said collecting means, the presence of said current limiting resistor rendering said current sensing means insensitive to such an abnormal impedance condition in said collecting means, a pair of spaced terminals connected across said limiting resistance in parallel with said resistance, and providing an intermittent voltage breakdown spark gap to sustain an intermittent predetermined high current when a predetermined voltage is developed across said limiting resistance upon said abnormal condition existing, said intermittent high current providing an intermittent loading on said power supply which is reflected to said current sensing means to produce an intermittent indication of the presence of said abnormal condition.

5. In an electronic gas purifying system, means for indicating a fault in the collecting section thereof comprising: power supply means providing a relatively high direct current potential and having a pair of output terminals; current limiting means; gas particle collecting means normally having a relatively high electrical impedance; means including said current limiting means connecting said collecting means across the output terminals of said power supply means; first and second terminal means; means connecting said first and second terminal means across said current limiting means; said terminal means being spaced from one another such that an abnormally low impedance condition in said collecting means causes voltage breakdown and current flow between said terminal means; and indicating means responsive to the flow of current between said terminal means when said voltage breakdown condition exists.

6. In an electronic gas purifying system, the combination comprising: power supply means having a pair of output terminals and providing a high voltage direct current potential at said output terminals; current limiting means normally having a relatively high electrical impedance; particle collecting means; means including said current limiting means connecting said collector means across the output terminals of said power supply means; further means including spaced terminal means connected in parallel with said current limiting means, said further means also including arc quenching impedance means; said terminal means being critically spaced so that abnormally low impedance at said particle collecting means results in a voltage breakdown across said terminal means and current flow therebetween; said arc quenching impedance means being effective to cause periodic interruption of current flow between said terminal means during a period of such abnormally low impedance at said collecting means; and indicating means responsive to current flow between said spaced terminal means to indicate the presence of a condition resulting in an abnormally low impedance at said collector means.

7. In an electronic gas purifying system, the combination comprising: power supply means having a low volt-

9

age input circuit and having high voltage output terminals; current limiting impedance means; particle collecting means normally having a relatively high electrical impedance; means including said current limiting means connecting said collector means across the high voltage terminals of said power supply means; further means including spaced terminal means connected in parallel with said current limiting means, said further means also including arc quenching impedance means connected in series circuit with said spaced terminal means; said terminal means being critically spaced so that abnormally low impedance at said particle collecting means results in a voltage breakdown across said terminal means and current flow therebetween; said arc quenching impedance means being effective to cause periodic interruption of current flow between said terminal means during a period of such abnormally low impedance at said collecting means; and indicating means connected in the low voltage circuit of said power supply means and responsive to current flow between said spaced terminal means to indicate the presence of a condition resulting in an abnormally low impedance at said collector means.

8. In an electronic gas purifying system, the combination comprising: power supply means for converting low voltage alternating current to high voltage direct current, said power supply means including a low voltage input circuit and high voltage output terminals; current limiting impedance means; particle collecting means normally having a relatively high electrical impedance; means including said current limiting impedance means connecting said collector means across the high voltage terminals of said power supply means; further means including spaced terminal means connected in parallel with said current limiting impedance means, said further means also including arc quenching impedance means including a relatively small capacitor and a relatively high impedance by-pass means in parallel therewith; said terminal means being critically spaced so that an abnormally low impedance as a short circuit at said particle collecting means results in a voltage breakdown across said terminal means and current flow therebetween; said arc quenching impedance means being effective to cause periodic interruption of current flow between said terminal means during a period of such abnormally low impedance at said collecting means; and indicating means connected in the low voltage circuit of said power supply means and responsive to current flow between said spaced terminal means to indicate the presence of a condition resulting in an abnormally low impedance at said collector means.

9. In an electronic gas purifying system, the combination comprising: power supply means for converting low voltage alternating current to high voltage direct current, said power supply means having a low voltage input circuit, in a high voltage output terminal and a grounded terminal; a current limiting resistor; particle collecting means including first and second sets of plates interleaved and spaced apart from one another; means including said current limiting resistor electrically connecting said first set of plates to said high voltage terminal of said power supply means; means electrically connecting said second set of plates to the grounded terminal of said power supply means; further means including spaced terminal means electrically connected in parallel with said current limiting resistor, said further means also including arc quenching impedance means connected in series circuit with said spaced terminal means, said arc quenching impedance means including a relatively small capacitor and a relatively high impedance by-pass means, in parallel therewith; said terminal means being critically spaced so that abnormally low impedance at said particle collecting means, as by a short circuit between said first and second sets of plates, results in a voltage breakdown across said terminal means and current flow therebetween;

10

said arc quenching impedance means being effective to cause periodic interruption of current flow between said terminal means during a period of such abnormally low impedance at said collecting means; and indicating means connected in the low voltage circuit of said power supply means and responsive to current flow between said spaced terminal means to indicate the presence of a condition resulting in an abnormally low impedance at said collector means.

10. In an electronic gas purifying system, the combination comprising: a housing for the purifying system and including a system access door; power supply means for converting relatively low alternating current potential to relatively high direct current potential, said power supply means including a low voltage input circuit, a high voltage output terminal and a grounded terminal; gas particle ionizing means having a first and second set of electrodes interleaved and spaced apart from one another; gas particle collecting means having a first and second set of plates interleaved and spaced apart from one another; means electrically connecting said first set of electrodes in common with the high voltage terminal of said power supply means; means electrically connecting said second set of electrodes in common with the grounded terminal of said power supply; current limiting means; means including said current limiting means electrically connecting said first set of plates in common with said high voltage terminal; means electrically connecting said second set of plates in common with said grounded terminal of said power supply; first and second shorting terminal means; means electrically connecting said first terminal means in common with said first set of electrodes; said last named means including arc quenching impedance means including a relatively small capacitor and relatively high impedance by-pass means in parallel therewith; means electrically connecting said second terminal in common with said first set of plates; a grounded shorting bar; means operable by said access door to bridge said shorting bar across said shorting terminals upon the opening of the access door to the system, said shorting terminal means being spaced from one another so that an abnormally low impedance between said first and second set of plates causes a voltage breakdown of, and current flow between said first and second shorting terminals; said arc quenching impedance means being effective to cause periodic interruption of current flow between said shorting terminal means during a period when such low impedance condition exists; and indicating means connected in the low voltage circuit of said power supply responsive to current flow between said terminal means for indicating the presence of said low impedance condition between said first and second set of plates.

11. In an electronic gas purifying system, the combination comprising: power supply means having a low voltage input circuit and having high voltage output terminals; ionizing means; current limiting means; particle collecting means; means electrically connecting said ionizing means across the high voltage terminals of said power supply means; means including said current limiting means electrically connecting said collecting means across the high voltage terminals of said power supply means; shorting terminal means connected across said current limiting means and including at least two terminals spaced apart from one another such that an abnormally low impedance in said collecting means causes voltage breakdown between said terminal means to thereby increase the load on said power supply; a housing for said ionizing and collecting means and including a door therein providing access to said ionizing and collecting means; means cooperable with said terminal means and operable by said access door to short said terminal means to ground to remove the electrical charge on said ionizing means and said collecting means upon the opening of the access door; and current sensing means connected in the low voltage circuit of said power supply, responsive to the in-

11

crease in load on said power supply resulting from voltage breakdown between said terminal means.

References Cited by the Examiner

UNITED STATES PATENTS

2,200,085	5/40	Hildebrand	55—104
2,233,639	3/41	Pegg	55—118
2,542,054	2/51	Penney et al.	55—122

5

12

2,632,522	3/53	Fields	55—104
2,873,000	2/59	Elam	55—138
2,925,534	2/60	Ferguson	55—141
3,028,715	4/62	Nodolf	55—138

FOREIGN PATENTS

640,456	7/50	Great Britain.
---------	------	----------------

HARRY B. THORNTON, *Primary Examiner.*