

(19) **DANMARK**



Patent- og  
Varemærkestyrelsen

(10) **DK/EP 2877587 T3**

(12) **Oversættelse af  
europæisk patentskrift**

- 
- (51) Int.Cl.: *C 12 P 5/02 (2006.01)*      *C 12 M 1/107 (2006.01)*      *C 12 M 1/42 (2006.01)*  
*C 12 N 1/20 (2006.01)*      *C 12 N 13/00 (2006.01)*      *C 25 B 1/02 (2006.01)*  
*C 25 B 3/04 (2006.01)*      *C 25 B 9/00 (2006.01)*      *C 25 B 15/02 (2006.01)*  
*C 25 B 15/08 (2006.01)*
- (45) Oversættelsen bekendtgjort den: **2017-12-11**
- (80) Dato for Den Europæiske Patentmyndigheds bekendtgørelse om meddelelse af patentet: **2017-09-06**
- (86) Europæisk ansøgning nr.: **13776565.7**
- (86) Europæisk indleveringsdag: **2013-07-29**
- (87) Den europæiske ansøgnings publiceringsdag: **2015-06-03**
- (86) International ansøgning nr.: **IB2013056215**
- (87) Internationalt publikationsnr.: **WO2014016815**
- (30) Prioritet:      **2012-07-27 ZA 201205680**      **2012-09-14 ZA 201206901**
- (84) Designerede stater: **AL AT BE BG CH CY CZ DE DK EE ES FI FR GB GR HR HU IE IS IT LI LT LU LV MC MK MT NL NO PL PT RO RS SE SI SK SM TR**
- (73) Patenthaver: **FFGF Limited, Sea Meadow House , Road Town, Tortola, Britiske Jomfruøer**
- (72) Opfinder: **WOLFOWITZ, Steven Alan, 18 Neels Street, Menkenkop, 6520 Hartenbos, Sydafrika**
- (74) Fuldmægtig i Danmark: **RWS Group, Europa House, Chiltern Park, Chiltern Hill, Chalfont St Peter, Bucks SL9 9FG, Storbritannien**
- (54) Benævnelse: **FREMGANGSMÅDE TIL FREMSTILLING AF METHAN OG APPARAT, DER ER EGNET DERTIL**
- (56) Fremdragne publikationer:  
**WO-A1-2010/007602**  
**WO-A1-2010/147683**  
**WO-A1-2011/003081**  
**WO-A1-2011/055322**  
**WO-A1-2012/110257**  
**WO-A2-2012/158941**  
**US-A1- 2009 317 882**  
**US-A1- 2011 165 667**  
**SHAOAN CHENG ET AL: "Direct Biological Conversion of Electrical Current into Methane by Electromethanogenesis", ENVIRONMENTAL SCIENCE & TECHNOLOGY, AMERICAN CHEMICAL SOCIETY, US, vol. 43, no. 10, 26 March 2009 (2009-03-26), pages 3953-3958, XP008150151, ISSN: 0013-936X, DOI: 10.1021/ES803531G**



# DESCRIPTION

## BACKGROUND OF THE INVENTION

**[0001]** The planet Earth is currently plagued by two major problems having severe effects on it and its inhabitants, namely: global warming resulting from excessive carbon dioxide production; and excessively high crude oil and consequently high petrol and diesel prices.

**[0002]** An object of this invention is to reduce these problems.

**[0003]** The increase in production of fossil fuel utilizing engines has resulted in excessive demand for crude oil in turn resulting in excessively high prices. The consumption of these fuels and that by oil, gas and coal-fired power stations, etc., has increased the amount of carbon dioxide produced which has led to global warming. The absorption of carbon dioxide by trees and resulting release of oxygen has been debilitated by the removal of extensive forests. This imbalance has thrown and continues to cumulatively throw the world's ecology out of kilter.

**[0004]** Efforts to improve efficiencies of engines and reduce wastage of fossil fuel products have little chance of improving the situation because of exponentially growing populations and their aspirations. Other technologies are actively being sought.

**[0005]** Ways to address the problems mentioned above includes.

reduction of carbon dioxide in the atmosphere;

reduction of 'carbon footprint' (the use of carbon products); and

reduction of demand for crude oil and other fossil fuels (resulting in a decrease in their prices, by finding replacements).

**[0006]** WO 2011/055322 A and WO 2010/007602 A disclose a process and an apparatus for the production of hydrogen, oxygen and hydrocarbons from carbon dioxide and water.

**[0007]** S.Cheng et al. ("Direct Biological Conversion of Electric Current into Methane by Electromethanogenesis" Environmental Science & Technology, American Chemical Society, vol. 43, no. 10, 26 March 2009, pages 3953-3958), US 2009/317882 A1 and WO 2012/158941 A disclose a method for producing methane wherein an anode vessel and a cathode vessel comprising methanogens are connected and electric current is applied.

**[0008]** WO 2012/158941 A discloses an apparatus in the form of a microbial fuel cell suitable for the production of hydrogen, electrical current or methane.

**[0009]** WO 2012/110257 discloses a process for producing methane by methanogenesis in a reaction vessel by contacting methanogens with an in-gas feed comprising hydrogen and carbon dioxide, wherein the methane production phase is conducted with a ratio of the partial pressure of hydrogen to the partial pressure of carbon dioxide inside the reaction vessel being maintained at 5:1 or higher.

**[0010]** US 2011/165667 A discloses a system to convert electric power into methane, the system comprising a reactor having a first chamber and a second chamber separated by a proton permeable barrier, the first chamber comprising a passage between an inlet and an outlet containing at least a porous electrically conductive cathode, a culture comprising living methanogenic microorganisms, and water, and the second chamber comprising at least an anode, the reactor having an operating state wherein the culture is maintained at a temperature above 50° C, a source of electricity coupled to the anode and the cathode; and a supply of carbon dioxide coupled to the first chamber wherein the outlet receives methane from the first chamber.

**[0011]** WO 2011/003081 A discloses a system to convert electric power into methane, the system comprising: a biological reactor having at least a first chamber containing at least a cathode, a culture comprising methanogenic microorganisms, and water, and a second chamber containing at least an anode, the biological reactor having an operating state wherein the culture

is maintained at a temperature above 50°C, a source of electricity coupled to the anode and the cathode, a supply of carbon dioxide coupled to the first chamber; and an outlet to receive methane from the first chamber.

[0012] It is an object of this invention to provide a method and apparatus which contributes to the above reductions and further provides for the production of methane.

#### **SUMMARY OF THE INVENTION**

[0013] This invention relates to a method for producing methane from carbon dioxide, hydrogen and anaerobic Archaea methanogen/s provided in an aqueous growth substrate and the aqueous growth substrate is pressurized to a pressure of from 5 to 1000 bar, typically from 5 to 500 bar, preferably from 5 to 200 bar, more preferably from 10 to 150 bar, more preferably from 20 to 150 bar, most preferably from 40 to 150 bar with a pressurizing fluid consisting of liquid carbon dioxide, or a mixture of liquid carbon dioxide and hydrogen.

[0014] Preferably, the method is carried out in a reaction vessel in which sufficient aqueous growth substrate is provided to provide an aqueous growth substrate to head space volumetric ratio of 1:1 to 4:1, typically a volumetric ratio from 2:1 to 3:1.

[0015] The aqueous growth substrate may be pressurized with a mixture of hydrogen and carbon dioxide which may be present in a molar ratio of 4:1 to 1:4, from 2:1 to 1:4, from greater than 1:1 to 1:4 or even from 1:2 to 1:4.

[0016] The pH of the aqueous growth medium is preferably maintained in the range from 6 to 7.5, preferably 6.5 to 7.

[0017] The methanogen/s may be a hyperthermophilic hyperextremophile or, psychrophile/cryophile and/or an exoelectrogenic microbiological organism.

[0018] The method is carried out at a temperature at or near the optimum for growth of the methanogen/s.

[0019] In the case where the methanogen/s is/are a hyperthermophilic hyperextremophile anaerobic Archaea, the reaction vessel may be operated at a temperature of 50°C to 400°C, preferably 80°C to 200°C, more preferably 80°C to 150°C.

[0020] In the case where the methanogen/s is/are a psychrophile/cryophile anaerobic Archaea, the reaction vessel may be operated at a temperature of -50 to 50°C, preferably -5 to -20°C, most preferably about -15°C.

[0021] Preferably, the pH of the aqueous growth medium is controlled.

[0022] The pH of the aqueous growth medium may be controlled by providing a cathode in the reaction vessel and passing a current through the aqueous growth medium to generate hydrogen and also to control the pH with electrolysis.

[0023] According to the invention, there is provided a method for the production of methane from carbon dioxide, hydrogen and anaerobic Archaea methanogen/s which includes the steps of:

1. a) providing an anode reaction vessel (14) containing a positive electrode (anode) and a liquid electrolytic medium comprising water and ionizing material;
2. b) providing a cathode reaction vessel (12) containing a negative electrode (cathode), an electrolytic aqueous growth substrate, methanogen/s and carbon dioxide and hydrogen wherein the cathode vessel (12) and aqueous growth substrate is pressurized to a pressure of from 5 to 1000 bar with a pressurizing fluid consisting of liquid carbon dioxide, or a mixture of liquid carbon dioxide and hydrogen;
3. c) connecting the first and second reaction vessels with connection means which allows electrons and/or ions, to pass between the electrolytic media of the anode and cathode reaction vessels;
4. d) applying a direct electrical current to the positive electrode and the negative electrode to:
  - o effect ionization of hydrogen in the cathode reaction vessel (12) to produce hydrogen and also to increase the pH of the electrolytic aqueous growth substrate; and
  - o effect ionized oxygen in the first reaction vessel (14), to form oxygen,

wherein electrolysis is implemented intermittently to control the pH in the cathode vessel (12). Methane is recovered from the cathode reaction vessel (12).

[0024] Oxygen is recovered from the first reaction vessel (14).

**[0025]** The reaction vessels (12) and (14) are operated at the same internal pressure, and may be operated at different temperatures.

**[0026]** The connection means is preferably an electrolytic medium, in which case a membrane which allows electrons to pass through, and possibly some ions, is provided.

**[0027]** Preferably, the connection means is provided with a valve that is insulated from the electrolyte.

**[0028]** The reaction vessels may be operated under different conditions, for example the anode reaction vessel (14) may be operated at ambient temperature at about 25°C; and the cathode reaction vessel (12) may be operated at a temperature at or near the optimum for growth of the methanogen/s.

**[0029]** In the case where the methanogen/s is/are a hyperthermophilic hyperextremophile anaerobic Archaea, the cathode reaction vessel (12) may be operated at a temperature of 50°C to 400°C, preferably 80°C to 200°C, more preferably 80°C to 150°C.

**[0030]** In the case where the methanogen/s is/are a psychrophile/cryophile anaerobic Archaea, the cathode reaction vessel (12) may be operated at a temperature of -50 to 50°C, preferably -5 to -20°C, most preferably about -15°C.

**[0031]** The cathode reaction vessel (12) is pressurized and the anode reaction vessel (14) may be pressurized to a pressure of from 5 to 1000 bar, typically from 5 to 500 bar, preferably from 5 to 200 bar, more preferably from 10 to 150 bar, more preferably from 20 to 150 bar, most preferably from 40 to 150 bar with a pressurizing fluid containing or comprising liquid carbon dioxide and hydrogen.

**[0032]** The cathode reaction vessel (12) may be pressurized with a mixture of hydrogen and carbon dioxide which may be present in a molar ratio of 4:11 to 1:4, from 2:1 to 1:4, from greater than 1:1 to 1:4 or even from 1:2 to 1:4.

**[0033]** Preferably, sufficient aqueous growth substrate is provided in the cathode reaction vessel (12) to provide an aqueous growth substrate to head space volumetric ratio of 1:1 to 4:1, typically a volumetric ratio of 2:1 to 3:1.

**[0034]** The pH of the aqueous growth medium is preferably maintained in the range from 6 to 7.5, preferably 6.5 to 7.

**[0035]** The voltage applied across the positive electrode and the negative electrode may be from -0.2v to -40v, -2v to -40v, -10v to -40v, -20 to -40v, typically -25v to -35v.

**[0036]** The direct electrical current flowing across the positive electrode and the negative electrode may be approximately 75-125 mAmps.

**[0037]** According to a further subject of the invention, there is provided an apparatus for the production of methane from carbon dioxide, hydrogen and anaerobic Archaea methanogen/s comprising:

a cathode reaction vessel (12) for containing carbon dioxide and electrolytic water;

an anode reaction vessel (14) for containing electrolytic water;

a negative electrode (cathode) capable of supporting anaerobic Archaea methanogens located within the cathode reaction vessel (12);

a positive electrode (anode) located within the anode reaction vessel (14); and

connection means for connecting electrolytic water in the cathode reaction vessel (12) and anode reaction vessel (14) so that an electric current can flow between the two, characterized in that the cathode reaction vessel (12) and the anode reaction vessel (14) are adapted to be pressurized to a pressure of from 5 to 1000 bar, the cathode reaction vessel (12) is adapted to be pressurized with a pressurizing fluid consisting of liquid carbon dioxide or a mixture of liquid carbon dioxide and hydrogen, and internal surfaces of cathode reaction vessel (12) and anode reaction vessel (14) are made from non-conductive non-corrosive materials that insulate the electrolytic media from the rest of the apparatus, except for the cathode and anode which come in to contact with electrolytic water within the reaction vessels, and wherein the apparatus comprises means for monitoring the pH.

**[0038]** The cathode reaction vessel (12) and the anode reaction vessel (14) are preferably adapted to be pressurized to a

pressure of from 5 to 500 bar, preferably from 5 to 200 bar, more preferably from 10 to 150 bar, more preferably from 20 to 150 bar, most preferably from 40 to 150 bar.

[0039] The connection means is preferably a conduit containing liquid electrolyte,

[0040] The conduit may include a semi-pervious membrane which allows the passage of ions between the electrolytic water in the anode reaction vessel (14) and cathode reaction vessel (12).

[0041] Preferably, the conduit has a valve which does not make electrical contact with the electrolyte.

[0042] The negative electrode in the cathode reaction vessel (12) is preferably in the form of a porous structure capable of supporting methanogens and biofilms they may generate. For example, the negative electrode in the second reaction vessel (12) is a hollow microporous cylinder which is closed at one end and which is made from a Pt amalgam or Pt, or Platinum Group Metal, or Titanium, or Platinum Group Metal plated Titanium.

[0043] The positive electrode in the anode reaction vessel (14) is preferably made of Pt or Platinum Group metal, or electroplated Titanium.

[0044] The internal surfaces of the reaction vessels may be made from non-conductive high temperature, high pressure withstanding materials, for example PEEK (polyether ether ketone), and insulate the electrolytic media from the rest of the apparatus, except for the cathode and anode which come in to contact with solution within the reaction vessels. The cathode reaction vessel is adapted to be pressurised with a pressurizing fluid.

[0045] Preferably, the apparatus includes means for equalizing the pressure in the cathode reaction vessel (12) and anode reaction vessel (14).

[0046] The pressure equalizing means is pressurized by the pressurizing fluid used to pressurize the cathode reaction vessel (14) which also simultaneously pressurizes the anode reaction vessel (12).

[0047] Preferably, the pressurizing equalizing means provides electrical insulation between the cathode reaction vessel (12) and anode reaction vessel (14).

[0048] The pressure equalizing means may comprise a non-conductive high tensile high temperature resistant tube with a piston located therein, and an indicator for indicating the position of the piston within the tube.

[0049] Preferably, the apparatus includes heat control means for heating or cooling the cathode reaction vessel (12).

[0050] Preferably, a stirrer is provided within the cathode reaction vessel (12).

[0051] The conduit may be located in a non-conductive and heat-resistant barrier between the cathode reaction vessel (12) and anode reaction vessel (14).

## **BRIEF DESCRIPTION OF THE DRAWINGS**

### **[0052]**

Figure 1

is side view of a reactor according to an embodiment of the invention;

Figure 2

is cross-sectional view of the reactor shown in Figure 1, through the line 2-2;

Figure 3

is a cross-sectional view of an apparatus for equalizing the pressure within the reactor vessels on the reactor according to an embodiment of the invention;

Figure 4

is a graph showing the results of an experiment to determine the influence of CO<sub>2</sub> on the pH of electrolytic aqueous growth substrate;

Figure 5

is a graph showing the results of an experiment to determine the effect of electrolysis on the pH of electrolytic media used

in the present invention;

Figure 6

is a graph showing the results of an experiment with *Mc. thermolithotrophicus*, 5 bar, 30 V, 65°C;

Figure 7

is a graph showing the results of an experiment with *Mc. thermolithotrophicus*, 5 bar, 12 V, 65°C;

Figure 8

is a graph showing the results of an experiment with *Mc. thermolithotrophicus*, 10 bar, 30 V, 65°C;

Figure 9

is a graph showing the results of an experiment with *Mc. thermolithotrophicus*, 20 bar, 30 V, 65°C;

Figure 10

is a graph showing the results of an experiment to show that oxygen is produced in the anode reaction vessel of the invention;

Figure 11

is a graph showing the results of an experiment with *M. kandleri*, 10 bar, 30 V, 97°C;

Figure 12

is a graph showing the results of an experiment with *M. kandleri*, 20 bar, 30 V, 97°C;

Figure 13

is a graph showing the results of an experiment with *M. kandleri*, 20 bar, 30 V, 105°C;

Figure 14

is a graph showing the results of an experiment with *Mc. jannaschii* 10 bar, 30 V, 85°C;

Figure 15

is a graph showing the results of an experiment with *Mc. jannaschii* 10 bar, 30 V, 92°C;

Figure 16

is a graph showing the results of an experiment with *Mc. jannaschii* 20 bar, 30 V, 92°C; and

Figure 17

is a graph showing the results of an experiment with *Mc. jannaschii* 30 bar, 92°C.

#### **DETAILED DESCRIPTION OF THE INVENTION**

**[0053]** This invention relates to a method of producing methane from methanogen Archaea (methanogens) that are cultivated in an aqueous substrate solution, in the presence of carbon dioxide and hydrogen, at high pressure greater than or equal to 5 bar and up to 1000 bar using a pressurizing fluid containing or comprising carbon dioxide. The invention also relates to an apparatus for carrying out the methanogenesis reaction.

**[0054]** The methanogenesis reaction is maintained under anaerobic conditions.

**[0055]** With reference to Figures 1 and 2, methanogens are cultivated in a reactor indicated generally by the numeral 10. The reactor 10 comprises reaction chambers 12 and 14 which are adapted to operate at a temperature up to or greater than or equal to 500°C and at an internal pressure of greater than or equal to 5 bar and up to 1000 bar.

**[0056]** The reaction chambers 12 and 14 are defined in tubes 16 made from a non-conductive material able to withstand high temperatures (in this case polyether ether ketone (PEEK)), which is reinforced within a metal casing 18 held together by metal tie-bars 19.

**[0057]** Extending into the "anode" reaction chamber 14 is a positive electrode (anode) 20 made from sintered platinum or rhodium plated titanium. An outlet 22 is provided for removing material from the anode reaction chamber 14, and inlets 24 and 26 are provided for supplying material into the anode reaction chamber 14.

**[0058]** Extending into the "cathode" reaction chamber 12 is a negative electrode (cathode) 28 made from sintered platinum or rhodium plated titanium, or titanium. The negative electrode 28 has a hollow core 30, with a perforated disc 32 which is covered with a carbon cloth 34 that is capable of supporting methanogens and which is conducive to methanogens forming biofilms.

**[0059]** An insulating barrier 36, made from a non-conductive material, preferably PEEK, separates the reaction chambers 12 and 14, which are joined via a conduit 38 which extends through the barrier 36. The conduit 38 includes a valve mechanism which is used to open and close the conduit 38. The valve is insulated from the contents of the reaction chambers 12 and 14 and comprises a threaded sectioned smooth rod which when screwed inwards enables the smooth rod section to pass through

a 'dog-leg' in the conduit to effectively obstruct the electrolyte continuity when fully screwed in. A membrane is secured within a cavity receptacle within the conduit 38. The cavity receptacle is located within the conduit 38 on the anode side of the valve separating the two vessels 12 and 14 to house a pair of short sockets/bushes to secure the thin membrane between them. The sockets/bushes are located and fixed in position within the receptacle by a non-conductive circlip.

**[0060]** The distance between the electrodes 20 and 28 is preferably 60mm or less. The internal surfaces of the reaction chambers 12 and 14, including the valve electrolyte contacting surfaces, insulate electrolytic media within these chambers from the rest of the apparatus, except for the electrodes 20 and 28 which come in to contact with electrolytic media within the chambers 12 and 14.

**[0061]** Located within the cathode reaction chamber 12 below the carbon cloth 34 is a non-conductively coated magnetic stirrer bar 40 which is actuated by a rotatable magnetic stirrer mechanism 42.

**[0062]** An outlet 44 is provided for removing material from the cathode reaction chamber 12, and inlets 46, 48 and 50 are provided for supplying material into the cathode reaction chamber 12.

**[0063]** The outlets may have electrically, pneumatically or hydraulically activated solenoid valves (not shown in the drawings) connecting the reactors with the outlet connection means to outer collection or supply vessels.

**[0064]** The electrodes 20 and 28 are connected together and supplied with power by a DC power supply.

**[0065]** Means is provided to control the pressure within the anode reaction vessel 14 and to equalize its internal pressure with the pressure within cathode reaction vessel 12: with reference to Figure 3, pressurized CO<sub>2</sub> and/or H<sub>2</sub>/CO<sub>2</sub> mixture 60 is supplied directly to the inlet 50 of the cathode reaction vessel. The pressurized CO<sub>2</sub> and/or H<sub>2</sub>/CO<sub>2</sub> is connected to the anode reaction vessel via a high pressure equaliser 62 which prevents the CO<sub>2</sub> and/or CO<sub>2</sub>/H<sub>2</sub> mixture from contacting or reacting with the contents of anode reaction vessel 14. The high pressure equaliser 62 comprises a pipe 64 made from a non-conductive high tensile high temperature resistant tubing and is covered by a housing 66 which is capable of withstanding high pressures at and above 5 bar and up to 1000 bar. Located within the pipe 64 is a piston 68. The piston 68 can move along the length of the pipe 66 and seals the CO<sub>2</sub> and/or H<sub>2</sub>/CO<sub>2</sub> on the cathode side of the pipe 66 from electrolyte on the anode side of the pipe 64 while equally transmitting the pressure to the anode contents. An indicator is provided to indicate the position of the piston 68 within the pipe 64 - in this case the indicator is a magnetic metal ball 70 located within the piston 68 which activates light-emitting diodes (LEDs - not shown) placed along the length of the pipe 64. The LEDs light up when they come in to contact with the magnetic field of the magnetic ball 70, and thus indicate the position of the piston 68 within the pipe 64.

**[0066]** In use, before startup of the electrolytic process, the valve in the conduit 38 is closed and anode electrolyte is transferred in to the anode reaction vessel 14 through the inlet 26. The anode electrolyte comprises an aqueous solution containing 1.25M Mg<sub>2</sub>SO<sub>4</sub>.

**[0067]** An aqueous methanogens substrate solution is transferred in to the cathode reaction vessel 12 through the inlet 48. The aqueous substrate solution comprises a combination of minerals (mainly chloride, sulphate and carbonate salts as well as Wolfe's minerals, and methanogens vitamins such as Wolf's vitamins that are able to support methanogens. The solution has a pH in the range from 6 to 7.5, preferably 6.5 to 7. The solution is inoculated with methanogens cells under anaerobic conditions and then transferred in to the cathode reaction vessel via an inlet 46. Sufficient aqueous methanogens substrate solution is transferred into the cathode reaction vessel 12 to leave an anaerobic headspace. The ratio between the volume of the headspace and the volume of the solution is typically from 1:1 to 1:3.

**[0068]** The inlet 26 of the anode reaction vessel 14 is connected to the pressure equaliser 62. CO<sub>2</sub> is pumped in to the cathode reaction vessel 12 via the inlet 48 to purge the headspace of air including oxygen, which exits through the outlet 44. The inlets 24, 48 and 46 and also the outlets 22 and 44 are closed and the cathode reaction vessel 12 is pressurized with liquid CO<sub>2</sub>. When the pressure within the reaction vessels 12 and 14 is the same, the valve in the conduit 38 is opened and equal pressure is maintained within the reaction vessels 12 and 14 by making use of the high pressure equaliser 62. The pressure in the reaction vessels 12 and 14 may be maintained at 5 bar to 1000 bar. It has been found that increased pressure of CO<sub>2</sub> can lead to the lowering of the pH of the aqueous methanogens substrate solution. This is problematic when the pH reaches 5.5 and lower. Ideally the pH needs to be maintained in the range from 6 to 7.5, preferably 6.5 to 7.

**[0069]** The temperatures within the reaction vessels 12 and 14 may be the same, or they may be heated or cooled separately by heating or cooling recycled materials to the vessels. The temperature within the reaction vessel 12 may be controlled by heating an insulated copper or heat-conductive material 51 by means of a heating cartridge or element(s) near to it.

[0070] The methanogen/s may be anaerobic Archaea, which may be a hyperthermophilic, hyperextremophile or, psychrophile/cryophile and/or an exoelectrogenic microbiological organism.

[0071] Examples of methanogens include *Methanobacterium alcaliphilum*, *Methanobacterium bryantii*, *Methanobacterium congolense*, *Methanobacterium defluvii*, *Methanobacterium espanolae*, *Methanobacterium formicum*, *Methanobacterium ivanovii*, *Methanobacterium palustre*, *Methanobacterium thermaggregans*, *Methanobacterium uliginosum*, *Methanobrevibacter acididurans*, *Methanobrevibacter arbor iphilicus*, *Methanobrevibacter gottschalkii*, *Methanobrevibacter olleyae*, *Methanobrevibacter ruminantium*, *Methanobrevibacter smithii*, *Methanobrevibacter woesei*, *Methanobrevibacter wolinii*, *Methanothermobacter marburgensis*, *Methanothermobacter thermoautotrophicus*, *Methanobacterium thermoautotrophicus*, *Methanothermobacter thermoflexus*, *Methanothermobacter thermophilicus*, *Methanothermobacter wolfeii*, *Methanothermobacter sociabilis*, *Methanococcus bavaricum*, *Methanococcus parvum*, *Methanococcus chikuoensis*, *Methanococcus submarinus*, *Methanogenium frigidum*, *Methanogenium liminatans*, *Methanogenium marinum*, *Methanosarcina acetivorans*, *Methanosarcina barken*, *Methanosarcina mazei*, *Methanosarcina thermophila*, *Methanomicrobium mobile*, *Methanocaldococcus jannaschii*, *Methanococcus aeolicus*, *Methanococcus maripaludis*, *Methanococcus vannieli*, *Methanococcus voltaei*, *Methanothermococcus thermolithotrophicus*.

[0072] In the case where the methanogen/s is/are a hyperthermophilic hyperextremophile anaerobic Archaea, the cathode reaction vessel (12) may be operated at a temperature of 50°C to 400°C, preferably 80°C to 200°C, more preferably 80°C to 150°C. In the case where the methanogen/s is/are a psychrophile/cryophile anaerobic Archaea, the cathode reaction vessel (12) may be operated at a temperature of -50 to 50°C, preferably -5 to -20°C, most preferably about -15°C.

[0073] In addition to CO<sub>2</sub>, H<sub>2</sub> may be supplied to the cathode reaction chamber 12 via the inlet 50 respectively, so that the cathode reaction chamber is pressurized with a mixture of CO<sub>2</sub>/H<sub>2</sub>. The H<sub>2</sub> and CO<sub>2</sub> may be added in a molar ratio of 4:1 to 1:4, from 2:1 to 1:4, from 1:1 to 1:4 or even from 1:2 to 1:4. The concentrations of CO<sub>2</sub> and H<sub>2</sub> are maximised by excluding other materials for pressurization so that the maximum reactor system volume may utilized for conversion to CH<sub>4</sub>.

[0074] In accordance with the present invention, typical methanogens are thermophilic methanogenic archaea, for example:

of the class Methanococci, namely *Methanocaldococcus jannaschii* (formerly *Methanococcus jannaschii*) preferred temperature is 85°C, of the genus Methanopyrus, namely *Methanopyrus kandleri* - preferred temperature is 105°C, and

of the genus *Methanothermococcus*, namely *Methanothermococcus thermolithotrophicus* preferred temperature is 65°C.

[0075] An electrolysis reaction is initiated by applying a direct voltage of -0.2 up to -35v, typically -20 to -35v, across the positive electrode 20 and negative electrode 28. The direct electrical current flowing across the positive electrode and the negative electrode may be approximately 75 - 125 mAmps, typically about 100 mAmps. The applied charge ionizes atoms in the electrolytic media in the reaction vessels. The initiation of the electrolysis process causes nascent (ionized) hydrogen ions to be formed from the H<sub>2</sub>O present in the electrolytic medium. In accordance with the present invention, the electrolysis reaction not only produces hydrogen, but also increases the pH of the aqueous substrate solution and can be used to control the pH of the solution to a pH above 5.5 at which methanogens can not only produce methane but can also grow (i.e. reproduce), in the range from 6 to 7.5, preferably 6.5 to 7. According to a method according to the present invention, the pH of the aqueous substrate solution is initially provided in the correct range from 6 to 7.5 by the electrolytes in the medium. Pressurising with CO<sub>2</sub> increases the acidity and thus the pH decreases. Should the pH fall too low, electrolysis is implemented intermittently to increase alkalinity and drive the pH up into the required range.

[0076] Methane may be retrieved from the outlet 44. In the anode reaction vessel 14, the electron flow causes oxygen ions which are negatively charged to be attracted to the positively charged electrode 20 therewithin, thus liberating the oxygen molecules at the electrode. Oxygen product may be retrieved from the outlet 22.

[0077] The conduit 38, which may have unidirectional-flow cation properties, is necessary to allow the transfer of electrons and keep the liberated oxygen in the reaction vessel 14 away from the reaction vessel 12 to avoid recombination with carbon and/or hydrogen there and oxygen contamination of the anaerobic Archaea. The barrier 36 also serves to reduce heat conduction transfer so that different temperature conditions may be maintained in the reaction vessels 12 and 14 to enhance and facilitate the different reactions occurring therein and save energy costs.

[0078] If necessary, methanogens may be supplied into the reaction chamber 12 through the hollow core 30 of the electrode 28, and these settle on the carbon cloth 34 which provides a haven for the methanogens to develop biofilms and to perform

methanogenesis.

[0079] The charge polarization serves to separate the oxygen and methane produced from one another for sufficient short period for the methanogens to do their conversion work and also to enhance the process by enhanced electrolysis. During this process the oxygen is produced at the anode 20, away from the negatively charged cathode 28 where the methanogenesis reaction occurs providing sufficiently anaerobic conditions in the cathode vicinity while the current is flowing through the circuit.

[0080] The outgoing stream may be recycled after separation of the methane produced from unreacted materials, removal of the dead or inactive methanogens is achieved, and the process may be repeated continuously.

[0081] In accordance with a further aspect of the invention, it has been found that the methanogenesis reaction can be improved at higher pressures by adding hydrogen to the headspace of the cathode reaction vessel 14.

[0082] In accordance with an embodiment of the invention, a standard procedure was developed, and the standard conditions were:

Cathode: 100 ml head-space, 300 ml medium; Inoculum with 0,5 g frozen cells.

Anode: completely full with 1.25 M MgSO<sub>4</sub>-solution (~ 100 ml)

Voltage: 30 V

[0083] Procedure: Inoculation at room temperature, electrolysis starts automatically during the night. The first headspace measurement is on the next day in the morning. If the hydrogen content is > 50 vol. %, electrolysis is stopped. Then heating to appropriate temperature is started. Several headspace measurements are following (~ 3 h of incubation, 6 h of incubation, the next day in the morning) until the produced hydrogen has (completely) been converted into methane.

[0084] Experiments were conducted using the apparatus illustrated in Figures 1 - 3 and described above using three strains of hyperthermophilic methanogens: *Methanocaldococcus jannaschii* (formerly *Methanococcus jannaschii*), *Methanopyrus kandleri* - preferred temperature is 105°C, and *Methanothermococcus thermolithotrophicus*. All three strains have been tested according to this procedure.

[0085] The following experiments were conducted:

1. 1. *Mc. thermolithotrophicus*, 10 bar, 30 V, 65°C, 300 ml electrolyte/100 ml headspace
2. 2. *Mc. thermolithotrophicus*, 20 bar, 30 V, 65°C, 300 ml electrolyte/100 ml headspace
3. 3. *M. kandleri*, 10 bar, 30 V, 97°C, 300 ml electrolyte/100 ml headspace
4. 4. *M. kandleri*, 20 bar, 30 V, 97°C, 300 ml electrolyte/100 ml headspace
5. 5. *M. kandleri*, 20 bar, 30 V, 105°C, 300 ml electrolyte/100 ml headspace
6. 6. *Mc. jannaschii* 10 bar, 30 V, 85°C, 300 ml electrolyte/100 ml headspace
7. 7. *Mc. jannaschii* 10 bar, 30 V, 92°C, 300 ml electrolyte/100 ml headspace
8. 8. *Mc. jannaschii* 20 bar, 30 V, 92°C, 300 ml electrolyte/100 ml headspace

[0086] A summary of the test results is provided in the Table 1 below:

Table 1

	ORGANISM TEMPERATURE [°C]	EXAMPLE	DURATION [H]	PERCENTAGE COMPOSITION OF METHANE IN THE HEAD SPACE	CH4 PRODUCED IN TOTAL [ML]	CH4 PRODUCED PER ML OF CULTURE [ML/ML]	CH4 PRODUCTION RATE [ML/H]
1. 10 bar CO2 and 30 V	<i>Mc. thermolithotrophicus</i> 65	Example 6	45.75 in total 29 with heating	18	184	0.6	4/6.3
2. 20	<i>Mc. thermo-lithotrophicus</i> 65	Example 7	69 in total 51.5 with	22.5	399	1.3	5.8/7.7

	ORGANISM TEMPERATURE [°C]	EXAMPLE	DURATION [H]	PERCENTAGE COMPOSITION OF METHANE IN THE HEAD SPACE	CH4 PRODUCED IN TOTAL [ML]	CH4 PRODUCED PER ML OF CULTURE [ML/ML]	CH4 PRODUCTION RATE [ML/H]
bar CO <sub>2</sub> and 30 V			heating				
3. 10 bar CO <sub>2</sub> and 30V	<i>M. kandleri</i> 97	Example 9	41 in total 24 with heating	15	120	0.4	5
4. 20 bar CO <sub>2</sub> and 30 V	<i>M. kandleri</i> 97	Example 10	47 in total 40.5 with heating	25	400	1.3	9.9
5. 20 bar CO <sub>2</sub> and 30 V	<i>M. kandleri</i> 105	Example 11	48.5 in total and 29.5 with heating	19	285	0.95	9.7
6. 10 bar CO <sub>2</sub> and 30V	<i>Mc. jannaschii</i> 85	Example 12	41 in total and 22.5 with heating	30.5	244	0.8	10.8
7. 10 bar CO <sub>2</sub> and 30 V	<i>Mc. jannaschii</i> 92	Example 13	41.5 in total and 16 with heating	19.5	195	0.65	12.2
8. 20 bar CO <sub>2</sub> and 30 V	<i>Mc. jannaschii</i> 92	Example 14	41.5 in total and 22 with heating	31	465	1.55	21.1

[0087] The results reflected Table 1 indicate that the methane production rate and total vol. % of methane increase with increasing pressures and test temperatures. Incubation temperature for the respective organism should be around its temperature optimum.

[0088] With reference to Example 13 - experiment with *Methanocaldococcus jannaschii* at 30 V, 92°C and 10 bar:

About 57 vol.% H<sub>2</sub> was produced from electrolysis at 30 V (initial headspace) The methanogens converted the hydrogen completely to 19 vol.% CH<sub>4</sub> at a constant temperature of 92°C. The final volume percentage of H<sub>2</sub> in the headspace was 1 vol.%

The conversion rate of H<sub>2</sub> to CH<sub>4</sub> was 98.2%

The CH<sub>4</sub> production rate was 12.1 ml/h

[0089] With reference to Example 14 - experiment with *Methanocaldococcus jannaschii* at 30 V and 92°C and 20 bar:

65.5 vol.% H<sub>2</sub> was produced from electrolysis (initial headspace)

The methanogens converted the hydrogen completely to 31 vol.% CH<sub>4</sub> at a constant temperature of 92°C. The final volume percentage of H<sub>2</sub> in the headspace was 0.4 vol.%

The conversion rate of H<sub>2</sub> to CH<sub>4</sub> was 99.4 %

The CH<sub>4</sub> production rate was 21.1 ml/h

**[0090]** These two experiments are comparable because the temperature, the electrolyte, the ratio of headspace to medium, the procedure of inoculation and the voltage remained constant. No external hydrogen had been added.

**[0091]** These two experiments support the following conclusions:

1. 1. That increased pressure increases the efficiency and the biological production rate of CH<sub>4</sub> from H<sub>2</sub> (produced from H<sub>2</sub>O electrolysis) and CO<sub>2</sub>. The conversion rate in the 20 bar experiment was higher than in the 10 bar experiment.
2. 2. The methanogens used up all the produced hydrogen from the production of methane due to methanogenesis.
3. 3. Biological production of methane (methanogenesis) using the method of this invention does not necessarily require a 4:1 H<sub>2</sub>:CO<sub>2</sub> ratio. When CO<sub>2</sub> is in the excess the complete consumption of hydrogen may be favoured (compared to a 4:1 ratio hydrogen : CO<sub>2</sub>).

1 atm = 101,325 kPa

1 bar = 100 kPa

**[0092]** The Invention will now be described in more detail with reference to the following non-limiting Examples.

**Example 1**

**[0093]** In the examples, three methanogens *M. kandleri*, *M. thermolithotrophicus* and *M. jannaschii* were tested for the production of methane.

**[0094]** The following growth aqueous substrate solutions (growth media) were used in the Examples

**MJ Medium - for *M. jannaschii***

Additive	Amount
NaCl	30,0 g
NaHCO <sub>3</sub>	1,00 g
MgCl <sub>2</sub> x 6 H <sub>2</sub> O	4,10 g
MgSO <sub>4</sub> x 7 H <sub>2</sub> O	3,40 g
KCl	0,33 g
NH <sub>4</sub> Cl	0,25 g
K <sub>2</sub> HPO <sub>4</sub>	0,14 g
CaCl <sub>2</sub> x 2 H <sub>2</sub> O	0,14 g
(NH <sub>4</sub> ) <sub>2</sub> -Fe(SO <sub>4</sub> ) <sub>2</sub> x 6 H <sub>2</sub> O	0,01 g
NiCl <sub>2</sub> x 6 H <sub>2</sub> O	0,5 mg
NaSeO <sub>4</sub>	0,5 mg
Wolfe's Minerals 10x/pH 1,0/neutral	1,0 ml
Wolfe's Vitamins 10x	1,0 ml
Resazurin, 0,1%ig	1,0 ml
Na <sub>2</sub> S x 7-9 H <sub>2</sub> O	0,5 g
alternativ:	
Na <sub>2</sub> S x 2 H <sub>2</sub> O	0,25 g
H <sub>2</sub> O, ad	1000,0 ml

Wolfe's minerals		
Additive	Amount	Concentration
MgSO <sub>4</sub> x 7 H <sub>2</sub> O	30,0 g	123,70 mM
MnSO <sub>4</sub> x H <sub>2</sub> O	5,00 g	29,60 mM
NaCl	10,0 g	171,10 mM
FeSO <sub>4</sub> x 7 H <sub>2</sub> O	1,00 g	3,60 mM
CoCl <sub>2</sub> x 6 H <sub>2</sub> O	1,00 g	7,57 mM
CaCl <sub>2</sub> x 2 H <sub>2</sub> O	1,00 g	6,80 mM
ZnSO <sub>4</sub> x 7 H <sub>2</sub> O	1,80 g	6,30 mM
CuSO <sub>4</sub> x 5 H <sub>2</sub> O	0,10 g	0,40 mM
KAl(SO <sub>4</sub> ) <sub>2</sub> x 12 H <sub>2</sub> O	0,10 g	0,38 mM
H <sub>2</sub> BO <sub>3</sub>	0,10 g	1,62 mM
Na <sub>2</sub> MoO <sub>4</sub> x 2 H <sub>2</sub> O	0,10 g	0,41 mM
(NH <sub>4</sub> ) <sub>2</sub> Ni(SO <sub>4</sub> ) <sub>2</sub> x 6 H <sub>2</sub> O	2,80 g	7,08 mM
Na <sub>2</sub> WO <sub>4</sub> x 2 H <sub>2</sub> O	0,10 g	0,30 mM
Na <sub>2</sub> SeO <sub>4</sub>	0,10 g	0,53 mM
H <sub>2</sub> O, ad	1000,0 ml	

Wolfe's vitamins		
Additive	Amount	Concentration
Biotin	20 mg	81.9 µM
Folsäure	20 mg	45.3 µM
Pyridoxaminhydrochlorid = Vit. B6	100 mg	386.0 µM
Thiaminhydrochlorid = Vit. B1	50 mg	148.0 µM
Riboflavin = Vit. B2	50 mg	133.0 µM
Nikotinsäure	50 mg	406.0 µM
Cl <sub>2</sub> -Calciumpanthothenat	50 mg	105.0 µM
Cyanocobalamin = Vit. B12	1 mg	0.79 µM
p - Aminobenzoensäure = PABA	50 mg	365.0 µM
Liponsäure	50 mg	242.0 µM
H <sub>2</sub> O bidest. ad	1000 ml	

**SME Medium (synthetic sea water) - for *M. kandleri***

Additive	Amount
SME stock-solution	1000.0 ml
KH <sub>2</sub> PO <sub>4</sub>	0.5 g
NH <sub>4</sub> Cl	0.5 g
Wolfe's Minerals 10x/pH 1.0/neu-T	1.0 ml
Resazurin, 0.1%ig	1.0 ml
Na <sub>2</sub> S x 7-9 H <sub>2</sub> O	0.5 g
alternativ:	
Na <sub>2</sub> S x 2 H <sub>2</sub> O	0.25 g

SME stock-solution		
Additive	Amount	Concentration
NaCl	27.7 g	473.99 mM
MgSO <sub>4</sub> x 7 H <sub>2</sub> O	7.0g	28.4 mM
MgCl <sub>2</sub> x 6 H <sub>2</sub> O	5.5 g	27.1 mM
CaCl <sub>2</sub> x 2 H <sub>2</sub> O	0.75 g	5.1 mM
KCl	0.85g	8.7 mM
NaBr	0.1 g	0.87 mM
H <sub>3</sub> BO <sub>3</sub>	0.03 g	0.49 mM
SiCl <sub>4</sub> x 6 H <sub>2</sub> O	0.015 g	0.059 mM
KJ-Lsg., 0.1%ig	0.1 ml	0.30 µM
H <sub>2</sub> O. ad	1000.0 ml	

**MGG medium - for *M. thermolithotrophicus***

Additive	Amount
NaCl	19.00 g
NaHCO <sub>3</sub>	6.50 g
MgSO <sub>4</sub> x 7 H <sub>2</sub> O	3.40 g
MgCl <sub>2</sub> x 6 H <sub>2</sub> O	4.30 g
KCl	0.35 g
K <sub>2</sub> HPO <sub>4</sub> x 3 H <sub>2</sub> O	0.14 g
NH <sub>4</sub> Cl	0.25 g
CaCl <sub>2</sub> x 2 H <sub>2</sub> O	0.14 g
(NH <sub>4</sub> ) <sub>2</sub> Fe(SO <sub>4</sub> ) <sub>2</sub> x 6H <sub>2</sub> O	0.032 g
Wolfe's Minerals 10x/pH 1.0/neu-T	1.0 ml
Resazurin, 0.1%ig	1.0 ml
Na <sub>2</sub> S x 7-9 H <sub>2</sub> O	0.5 g
alternativ:	
Na <sub>2</sub> S x 2 H <sub>2</sub> O	0.25 g
H <sub>2</sub> O. ad	1000.0 ml

**Example 2 - CO<sub>2</sub>-experiment at 50 bar without electrolysis**

[0095] This experiment was performed to determine the influence of CO<sub>2</sub> on the pH value of the electrolyte.

[0096] The test was started at 65°C with 50 bar CO<sub>2</sub>. The electrolyte in the cathode chamber was SME, pH 7. The change of pH was monitored every 15 minutes. The results of the Experiments are shown in Table 2 below.

Table 2

DATE	TIME	PRESSURE	TEMPERATURE	PH AT THE CATHODE
5.12.12	11.00	atmospheric	65°C	7
5.12.12	13.50	50 bar CO <sub>2</sub>	65°C	7
5.12.12	14.05	50 bar CO <sub>2</sub>	65°C	6.5
5.12.12	14.20	50 bar CO <sub>2</sub>	65°C	5.5
5.12.12	14.35	50 bar CO <sub>2</sub>	65°C	5.5
5.32.32	14.50	50 bar CO <sub>2</sub>	65°C	5.5
5.12.12	14.02	80 bar CO <sub>2</sub>	65°C	pressurized up to 80 bar

DATE	TIME	PRESSURE	TEMPERATURE	PH AT THE CATHODE
5.12.12	14.17	80 bar CO <sub>2</sub>	65°C	5.5

[0097] The influence of CO<sub>2</sub> on the pH is shown in Figure 4.

[0098] Conclusion: At a pressure of 50 bar CO<sub>2</sub> the pH dropped from 7 to 5.5 and stayed constant at this value. A pH of 5.5 is the minimum pH the methanogens can tolerate.

#### **Example 3 - Electrolysis experiment at 65°C and atmospheric pressure (no CO<sub>2</sub> present)**

[0099] This experiment was conducted to determine the effect of the electrolysis reaction on pH when no CO<sub>2</sub> is present.

Electrolyte: SME (cathode), SME without chlorides (anode)

Voltage: 31.5 V constant

Gas phase: air

[0100] The results of the Experiments are shown Table 3 and Figure 5.

Table 3

	AT THE BEGINNING (AT 65°C)	AFTER 15 MM	AFTER 30 MIN	AFTER 45 MIN	AFTER 1 H	AFTER 2 H
Current	220 mA	250 mA	320 mA	300 mA	320 mA	300 mA
pH anode	6.5	5.5	3.5	2.5	2	2
pH cathode	8	9	10	11	11	11

[0101] The pH at the cathode increased from 8 to 11 and stayed constant at 11. The pH at the anode became acidic and dropped from 6.5 to 2.

[0102] Conclusion: Due to electrolysis the electrolyte in the cathode became alkaline and the anode reaction room became acidic. A pH of 11 at the cathode is far too high for the methanogens. Their pH range is from 5.5 to 8 with an optimum around 7. The electrolysis reaction can be used to control the pH of the solution.

#### **Example 4**

[0103] FFGF-reaction with *Mc. thermotithotrophicus* at 5 bar CO<sub>2</sub> and 30 V

Electrolyte cathode: 280 ml SME, pH 6.5

Electrolyte anode: Mg<sub>2</sub>SO<sub>4</sub>, 1.25 M

Inoculum: 0.8 g frozen cells and 20 ml liquid pre-culture

Gas-phase 5 bar CO<sub>2</sub>

Start electrolysis immediately after inoculation; when enough hydrogen is present, heat up to final temperature.

Voltage 30 V

[0104] The results of this experiment are shown in Figure 6.

[0105] In this experiment there was only CO<sub>2</sub> in the head-phase and no additional hydrogen. Hydrogen was produced only from electrolysis which was started immediately after inoculation. At a concentration of 45 % hydrogen heating was switched on in order to activate the methanogens. Electrolysis ran for another ~3.5 h until stopped. During night the methanogens produced - 15 % of methane from CO<sub>2</sub> and hydrogen. The last measurement showed that the head-space contains ~ 25 % methane. After the experiment it was noticed, that the frozen cells were lying on top of the cathode and did not re-suspend into the medium. Therefore, liquid pre-cultures in the following experiments.

#### **Example 5**

**[0106]** FFGF-reaction with *Mc. thermolithotrophicus* at 5 bar CO<sub>2</sub> and 12 V

Electrolyte cathode: 240 ml SME, pH 6.5

Electrolyte anode: Mg<sub>2</sub>SO<sub>4</sub>, 1.25 M

Inoculum: 60 ml liquid pre-culture

Gas-phase 5 bar CO<sub>2</sub>

Start electrolysis immediately after inoculation; when enough hydrogen is present, heat up to final temperature

Voltage 12 V

5 ml gas-sample discarded, 10 ml gas-sample analyzed

**[0107]** The results of this experiment are shown in Figure 7.

**[0108]** Under the same conditions as Example 4 but with electrolysis at 12 V it took longer to produce similar amounts of hydrogen from electrolysis (8 h and > 33 % H<sub>2</sub> vs. 2.5 h and 45 % H<sub>2</sub>). Electrolysis was stopped during the night. In the morning the methanogens had converted the hydrogen and CO<sub>2</sub> to ~ 6 % methane. Electrolysis was restarted to investigate if more methane is produced and that was the case: A final concentration of ~ 8 % CH<sub>4</sub> was reached. The yield is three times less when compared to the 5 bar experiment described in Example 4 with 30 V. It was concluded that more methane can be produced with higher voltage.

#### **Example 6**

**[0109]** FFGF-reaction with *Mc. thermolithotrophicus* at 10 bar CO<sub>2</sub> and 30 V Electrolyte cathode: 240 ml SME, pH 7

Electrolyte anode: Mg<sub>2</sub>SO<sub>4</sub>, 1.25 M

Inoculum: 60 ml liquid pre-culture

Gas-phase 10 bar CO<sub>2</sub>

Voltage 30 V

**[0110]** The results of this experiment are provided in Figure 8.

**[0111]** This experiment was performed at 10 bar CO<sub>2</sub> with no additional hydrogen. Hydrogen was produced from electrolysis at 30 V which has been started automatically at midnight. At this stage the reactor was at room temperature. In the morning when electrolysis ran for 8.5 h ~ 70 % H<sub>2</sub> in the gas-phase was measured. The reactor was heated to bring the methanogens into an active mode (see Fig 8). Electrolysis was started for ~ 3,5 h. The next day we could detect methane with a final concentration of ~ 18%.

#### **Example 7**

**[0112]** FFGF-reaction with *Mc. thermolithotrophicus* at 20 bar CO<sub>2</sub> and 30 V

Electrolyte cathode: 240 ml SME, pH 7

Electrolyte anode: Mg<sub>2</sub>SO<sub>4</sub>, 1.25 M

Inoculum: 60 ml liquid pre-culture

Gas-phase 20 bar CO<sub>2</sub>

A time switch controlled the automatic start of the electrolysis at 22.00 Voltage 30 V

**[0113]** The results of this experiment are provided in Figure 9.

**[0114]** This experiment was performed at 20 bar CO<sub>2</sub> with no additional hydrogen. Hydrogen was produced by electrolysis at 30 V which has been started automatically in the night at 22.00. At this stage the reactor was at room temperature. In the morning when electrolysis ran for 10.25 h ~ 63 % H<sub>2</sub> in the gas-phase was measured. Heating was switched on to activate the methanogens (see Fig 9). The final methane concentration was ~ 22.5 %.

#### **Example 8**

**[0115]** The gas at the anode was sampled and analyzed in the GC. With our GC machine detection of oxygen is possible (but

not quantification; nitrogen as carrier gas is not suited for the quantification of oxygen). But, to roughly estimate the amount of oxygen produced at the anode a "calibration curve" with two standards (100 % pure oxygen and air -21 % O<sub>2</sub>) was made. The resulting peaks had different areas (at the same retention time). By plotting the area - which is direct proportional to the amount of gas injected - against the volume percentage we got the "calibration curve" (see Fig. 10). After injection of the "anode" sample with unknown composition we could roughly estimate the volume percentage of oxygen with corresponded to ~30 % (Note that in this case electrolysis ran for ~ 13 h at 30 V). Although a calibration curve with only two measuring points and under given conditions (nitrogen gas as carrier) is inaccurate for an exact quantification we can say that the amount of oxygen in the anode is higher than that of the air. So it is proven that oxygen is being produced at the anode reactor.

**Example 9**

**[0116]** *M. kandleri* (97°C) at 10 bar CO<sub>2</sub> and 30 V, Inoculum with frozen cells

Electrolyte cathode: 280 ml SME, pH 6

Electrolyte anode: Mg<sub>2</sub>SO<sub>4</sub>, 1.25 M

Inoculum: 0.5 g frozen cells, resuspended in 20 ml SME under anaerobic conditions

Gas-phase 10 bar CO<sub>2</sub>

Start electrolysis (30 V) at room temperature in the night per timer for 6 h Start heating in the morning when enough hydrogen is present

15 ml gas sample taken, 5 ml discharged (dead volume), 10 ml used for analysis of 200 µl in duplicates

**[0117]** The results of this experiment are shown in Figure 11.

**[0118]** This 10 bar CO<sub>2</sub> experiment with *M. kandleri* did produce methane. Frozen cells were used as inoculum and this was a successful approach. Electrolysis started at room temperature and produced ~ 85 % hydrogen within 6 h. Within a day of incubation at 97°C the methanogens produced 15 Vol. % of CH<sub>4</sub>. Decided to use frozen *M. kandleri* cells for subsequent experiments.

**Example 10**

**[0119]** *M. kandleri* (97°C) at 20 bar CO<sub>2</sub> and 30 V, Inoculation with frozen cells

Electrolyte cathode: 280 ml SME, pH 6

Electrolyte anode: Mg<sub>2</sub>SO<sub>4</sub>, 1.25 M

Inoculum: 0.5 g frozen cells, resuspended in 20 ml SME under anaerobic conditions

Gas-phase 20 bar CO<sub>2</sub>

Start electrolysis (30 V) immediately after inoculation

Start heating when enough hydrogen is produced from electrolysis

**[0120]** The results of this experiment are provided in Figure 12.

**[0121]** In this experiment with 20 bar CO<sub>2</sub> we inoculated resuspended, frozen cells and immediately started electrolysis at room temperature. We stopped electrolysis in the evening after ~ 7 h and heated the reactor up (50 % H<sub>2</sub> present). Overnight *M. kandleri* converted H<sub>2</sub> and CO<sub>2</sub> into ~ 25 % methane. Then we restarted electrolysis but the current decreased rapidly to 0.07-0.01 A. After releasing the gas produced in the anode reactor (> 200 ml) the current flow was immediately increasing but only for a short time. Interestingly, the percentages of H<sub>2</sub> and CH<sub>4</sub> in the cathode head-space also decreased after the release of the anode-gas. As the current flow was low we could not produce more H<sub>2</sub>. The remaining H<sub>2</sub> (~ 6 % in the evening) was completely converted into methane over night by active methanogens.

**Example 11**

**[0122]** *M. kandleri* (105.5°C) at 20 bar CO<sub>2</sub> and 30 V, Inoculation with frozen cells

Electrolyte cathode: 280 ml SME, pH 6

Electrolyte anode: Mg<sub>2</sub>SO<sub>4</sub>, 1.25 M

Inoculum: 0,5 g frozen cells, resuspended in 20 ml SME under anaerobic conditions

Gas-phase 20 bar CO<sub>2</sub>

**[0123]** Start electrolysis (30 V) at room temperature in the night per timer for 6 h Start heating in the morning when enough hydrogen is present

15 ml gas sample taken, 5 ml discharged (dead volume), 10 ml used for analysis of 200 µl in duplicates

**[0124]** The results of this experiment are shown in Figure 13.

**[0125]** In this experiment electrolysis was started at room temperature. Within 8 h ~ 60 % of hydrogen was produced from electrolysis (at initial 20 bar CO<sub>2</sub> which is enough to support the growth of the methanogens. Heating started at 10.00 the methanogens immediately started to produce methane so that we could measure 2 % CH<sub>4</sub> in the evening (see Fig 13). Within 24 h the methanogens converted all hydrogen into methane to a final concentration of 19 %. If more hydrogen had been present the methanogens would have probably produced even more methane.

## **Example 12**

**[0126]** *Mc. jannaschii* at 10 bar CO<sub>2</sub>, 30 V and 85°C

Electrolyte cathode: 240 ml medium, pH 6.5 and 60 ml liquid pre-culture

Electrolyte anode: Mg<sub>2</sub>SO<sub>4</sub>, 1.25 M

Initial Gas-phase 10 bar CO<sub>2</sub>

Start electrolysis (30 V) at room temperature in the night per timer for 8 h Measure hydrogen content in the morning and add additional hydrogen if necessary; then start heating

15 ml sample taken, 5 ml discharged (dead volume), 10 ml used for analysis of 200 µl in duplets

**[0127]** The results of this experiment are provided in Figure 14.

**[0128]** Inoculated liquid pre-cultures and started with 10 bar CO<sub>2</sub>. Electrolysis ran for 8 h at 30 V. After 22.5 h of incubation at the final temperature (85°C) the methane concentration was - 30 Vol. % which corresponds to 244 ml methane in total. Then gas was released and external hydrogen added.

## **Example 13**

**[0129]** *Mc. jannaschii* at 10 bar CO<sub>2</sub>, 30 V and 92°C

Electrolyte cathode: 280 ml medium, pH 6.5 and 0.5 g frozen cells, resuspended in 20 ml under anaerobic conditions

Electrolyte anode: Mg<sub>2</sub>SO<sub>4</sub>, 1.25 M

Initial Gas-phase 20 bar CO<sub>2</sub>

Start electrolysis (30 V) at room temperature in the night per timer Measure hydrogen content in the morning and add additional hydrogen if necessary; then start heating

15 ml sample taken, 5 ml discharged (dead volume), 10 ml used for analysis of 200 µl in duplets

**[0130]** The results of this experiment are shown in Figure 15.

**[0131]** This test produced 19.5 vol. % in total without addition of external hydrogen (see Fig. 15). Within 41.5 h of total incubation time the methanogens converted all present hydrogen into methane.

## **Example 14**

**[0132]** *Mc. jannaschii* at 20 bar CO<sub>2</sub>, 30 V and 92°C

Electrolyte cathode: 280 ml medium, pH 6.5 and 0.5 g frozen cells, resuspended in 20 ml under anaerobic conditions

Electrolyte anode: Mg<sub>2</sub>SO<sub>4</sub>, 1.25 M

Initial Gas-phase 20 bar CO<sub>2</sub>

Start electrolysis (30 V) at room temperature in the night per timer Measure hydrogen content in the morning and add additional hydrogen if necessary; then start heating

15 ml sample taken, 5 ml discharged (dead volume), 10 ml used for analysis of 200 µl in duplets

[0133] The results of this experiment are shown in Figure 16.

[0134] This test produced 31 vol. % of methane which corresponds to 465 ml gaseous methane (see Fig. 16). No external hydrogen was added. All hydrogen present was produced from electrolysis and has been utilized by the methanogens for synthesis of methane.

#### **Example 15**

[0135] *Mc. jannaschii* at 92°C with addition of external hydrogen at 30 bar H<sub>2</sub>/CO<sub>2</sub>

Electrolyte cathode: 280 ml medium, pH 6.5 and 0.5 g frozen cells, resuspended in 20 ml under anaerobic conditions

Electrolyte anode: Mg<sub>2</sub>SO<sub>4</sub>, 1.25 M

Initial Gas-phase 15 bar CO<sub>2</sub> and 15 bar external hydrogen => 30 bar H<sub>2</sub>/CO<sub>2</sub> gas-phase with - 70/30 (v/v) H<sub>2</sub>/CO<sub>2</sub>

no electrolysis

15 ml sample taken, 5 ml discharged (dead volume), 10 ml used for analysis of 200 µl in duplets

Determination of the time taken to convert all the hydrogen of methane Determination of the CH<sub>4</sub> production rate

[0136] The results of this experiment are provided in Figure 17.

[0137] The experiment was started with an initial ratio of 80/20 (v/v) H<sub>2</sub>/CO<sub>2</sub> (see Fig. 17). It took 22.5 h of incubation at the final temperature for *Mc. jannaschii* to consume (nearly) all the hydrogen present. The total amount of methane was ~ 48 vol. % which corresponds to 1425 ml methane. The methane production rate for this experiment was 63 ml/h. The pH stayed constant at 6.5.

## REFERENCES CITED IN THE DESCRIPTION

This list of references cited by the applicant is for the reader's convenience only. It does not form part of the European patent document. Even though great care has been taken in compiling the references, errors or omissions cannot be excluded and the EPO disclaims all liability in this regard.

#### **Patent documents cited in the description**

- [WO2011055222A \[0006\]](#)
- [WO2010007802A \[0006\]](#)
- [US2009317682A1 \[0007\]](#)
- [WO2012158941A \[0007\] \[0008\]](#)
- [WO2012110257A \[0009\]](#)
- [US2011165667A \[0010\]](#)
- [WO2011003081A \[0011\]](#)

#### **Non-patent literature cited in the description**

- **S.CHENG et al.** Direct Biological Conversion of Electric Current into Methane by Electromethanogenesis Environmental Science & Technology, American Chemical Society, 2009, vol. 43, 103953-3958 [0007]

## Patentkrav

1. Fremgangsmåde til fremstilling af metan fra carbondioxid, hydrogen og et eller flere anaerobe Archaea-methanogener, som indbefatter trinene:
- 5 a) tilvejebringelse af en anodereaktionsbeholder (14), der indeholder en positiv elektrode (anode) og et væskeformigt elektrolytisk medium, der omfatter vand og ioniserende materiale;
- 10 b) tilvejebringelse af en katodereaktionsbeholder (12), der indeholder en negativ elektrode (katode), et elektrolytisk vandigt vækstsubstrat, methanogen(er), carbondioxid og hydrogen, hvor katodebeholderen (12) og det vandige vækstsubstrat påføres et tryk på fra 5 til 1000 bar med en
- 15 trykvæske, der består af væskeformig carbondioxid eller en blanding af væskeformig carbondioxid og hydrogen;
- c) kobling af den første og anden reaktionsbeholder med et koblingsmiddel, der åbner mulighed for, at elektroner og/eller ioner kan passere mellem de elektrolytiske medier i anode- og
- 20 katodereaktionsbeholderen;
- d) påføring af en direkte elektrisk strøm til den positive elektrode og den negative elektrode til:
- fremkaldelse af ionisering af hydrogen i katodereaktionsbeholderen (12) til frembringelse af hydrogen

25 og endvidere forhøjelse af pH i det elektrolytiske vandige vækstsubstrat; og

  - fremkaldelse af ioniseret oxygen i den første reaktionsbeholder (14) til frembringelse af oxygen,

hvor elektrolyse implementeres med mellemrum til kontrol af pH

30 i katodereaktionsbeholderen (12).
2. Fremgangsmåde ifølge krav 1, hvor reaktionsbeholder (12) og (14) opererer ved det samme indre tryk.
- 35 3. Fremgangsmåde ifølge krav 1, hvor koblingsmidlet er et elektrolytisk medium, hvor der tilvejebringes en membran, der åbner mulighed for, at elektroner kan passere igennem, og muligvis visse ioner, og koblingsmidlet er forsynet med en

ventil, der er isoleret fra elektrolytten.

4. Fremgangsmåde ifølge krav 1, hvor reaktionsbeholderne opererer ved forskellige temperaturer.

5

5. Fremgangsmåde ifølge krav 4, hvor anodereaktionsbeholderen (14) opererer ved omgivende temperatur; og katodereaktionsbeholderen (12) opererer ved en temperatur, der er på eller tæt på det optimale for vækst af methanogenet/methanogenerne.

10

6. Fremgangsmåde ifølge krav 5, hvor methanogenet/methanogenerne er en hypertermofil, hyperekstremofil anaerob Archaea, og hvor reaktionen udføres ved en temperatur på 50 °C til 400 °C, fortrinsvis 80 °C til 200 °C, mere fortrinsvis 80 °C til 150 °C.

15

7. Fremgangsmåde ifølge krav 5, hvor methanogenet/methanogenerne er en psykrofil/kryofil anaerob Archaea, og hvor reaktionen udføres ved en temperatur på -50 til 50 °C, fortrinsvis -5 til -20 °C.

20

8. Fremgangsmåde ifølge krav 1, hvor katodereaktionsbeholderen (12) og anodereaktionsbeholderen (14) påføres et tryk på 5 til 500 bar, fortrinsvis fra 5 til 200 bar, mere fortrinsvis fra 10 til 150 bar, mere fortrinsvis fra 20 til 150 bar, mest fortrinsvis fra 40 til 150 bar.

25

9. Fremgangsmåde ifølge krav 1, hvor katodereaktionsbeholderen (12) påføres et tryk med en trykvæske, der består af en blanding af hydrogen og carbondioxid.

30

10. Fremgangsmåde ifølge krav 9, hvor hydrogen og carbondioxid er til stede i et molforhold på 4:1 til 1:4, fortrinsvis 2:1 til 1:4, mere fortrinsvis 1:1 til 1:4, mest fortrinsvis 1:2 til 1:4.

35

11. Fremgangsmåde ifølge krav 10, hvor der tilvejebringes tilstrækkeligt vandigt vækstsubstrat i katodereaktionsbeholderen (12) til tilvejebringelse af et vandigt vækstsubstrat til headspace volumetrisk forhold på 1:1 til 4:1, fortrinsvis fra 2:1 til 3:1.

12. Fremgangsmåde ifølge krav 1, hvor pH i det vandige vækstmedium opretholdelse i intervallet fra 6 til 7,5, fortrinsvis fra 6,5 til 7.

10

13. Apparat til fremstilling af methan fra carbondioxid, hydrogen og anaerob(e) Archaea-methanogen(er), som omfatter: en katodereaktionsbeholder (12) til at indeholde carbondioxid og elektrolytisk vand;

15 en anodereaktionsbeholder (14) til at indeholde elektrolytisk vand;

en negativ elektrode (katode), der er i stand til at understøtte anaerobe Archaea-methanogener, der er placeret i katodereaktionsbeholderen (12);

20 en positiv elektrode (anode), der er placeret i anodereaktionsbeholderen (14); og

et koblingsmiddel til kobling af elektrolytisk vand i katodereaktionsbeholderen (12) og anodereaktionsbeholder (14), således at der kan strømme en direkte elektrisk strøm mellem de to,

25 der er kendetegnet ved, at katodereaktionsbeholderen (12) og anodereaktionsbeholderen (14) er indrettet til at blive påført et tryk på fra 5 til 1000 bar, katodereaktionsbeholderen (12) er indrettet til at blive påført et tryk med en trykvæske

bestående af væskeformig carbondioxid eller en blanding af væskeformig carbondioxid og hydrogen, og indre overflader af katodereaktionsbeholderen (12) og anodereaktionsbeholderen (14) er lavet af ikke-ledende, ikke-korroderende materialer,

30 der isolerer de elektrolytiske medier fra resten af apparatet, bortset fra katoden og anoden, der kommer i kontakt med elektrolytisk vand i reaktionsbeholderne, og hvor apparatet omfatter et middel til overvågning af pH.

35

14. Apparat ifølge krav 13, hvor katodereaktionsbeholderen (12) og anodereaktionsbeholderen (14) er indrettet til at blive påført et tryk på 5 til 500 bar, fortrinsvis 5 til 200 bar, mere fortrinsvis fra 10 til 150 bar, mere fortrinsvis fra 20 til 150 bar, mest fortrinsvis fra 40 til 150 bar.
15. Apparat ifølge krav 13, hvor koblingsmidlet er et rørledning, der indeholder væskeformig elektrolyt, hvilken rørledning indbefatter en semipermeabel membran, der åbner mulighed for passage af ioner mellem det elektrolytiske vand i katodereaktionsbeholderen (12) og anodereaktionsbeholderen (14), og rørledningen har en ventil, der ikke danner elektrisk kontakt med elektrolytten.
16. Apparat ifølge krav 13, der indbefatter et middel til udligning af trykket i katodereaktionsbeholderen (12) og anodereaktionsbeholderen (14), hvor trykudligningsmidlet trykpåføres ved hjælp af trykvæske, der anvendes til trykpåføring af katodereaktionsbeholderen (14), som også samtidig trykpåfører anodereaktionsbeholderen (12), og hvor trykudligningsmidlet tilvejebringer elektrisk isolering mellem katodereaktionsbeholderen (12) og anodereaktionsbeholderen (14).
17. Apparat ifølge krav 16, hvor trykudligningsmidlet omfatter et ikke-ledende rør med et stempel placeret deri og en indikator til visning af positionen af stemplet i røret.

**DRAWINGS**

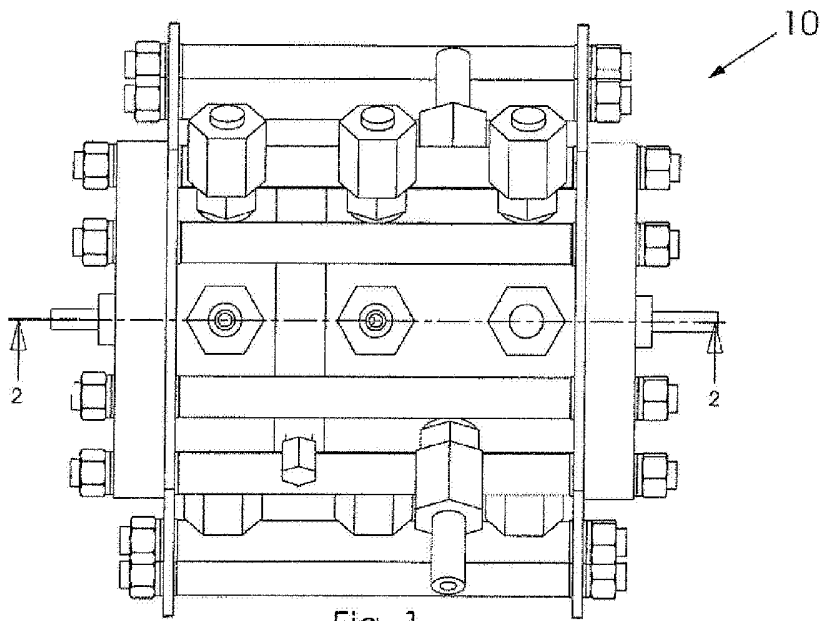

Fig. 1

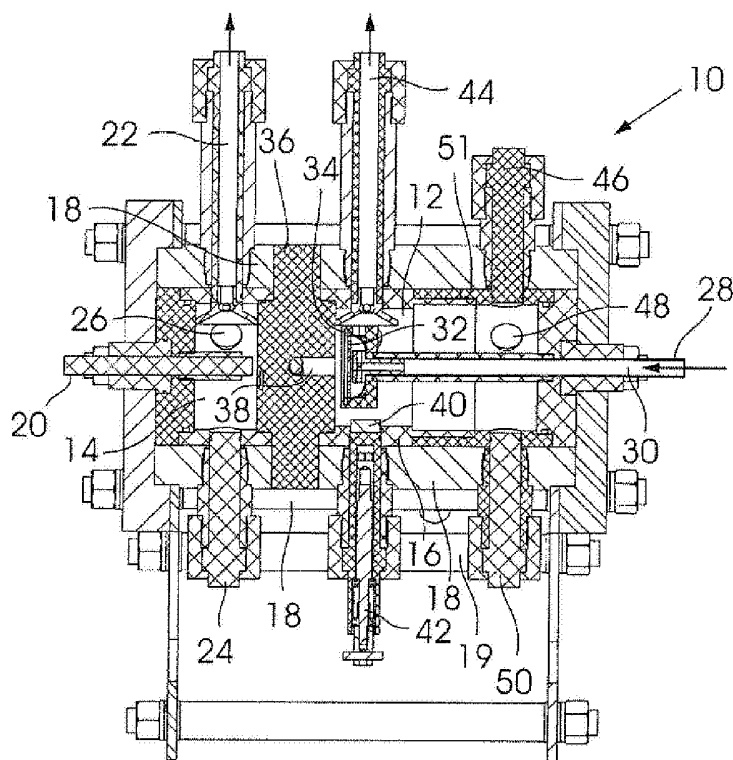
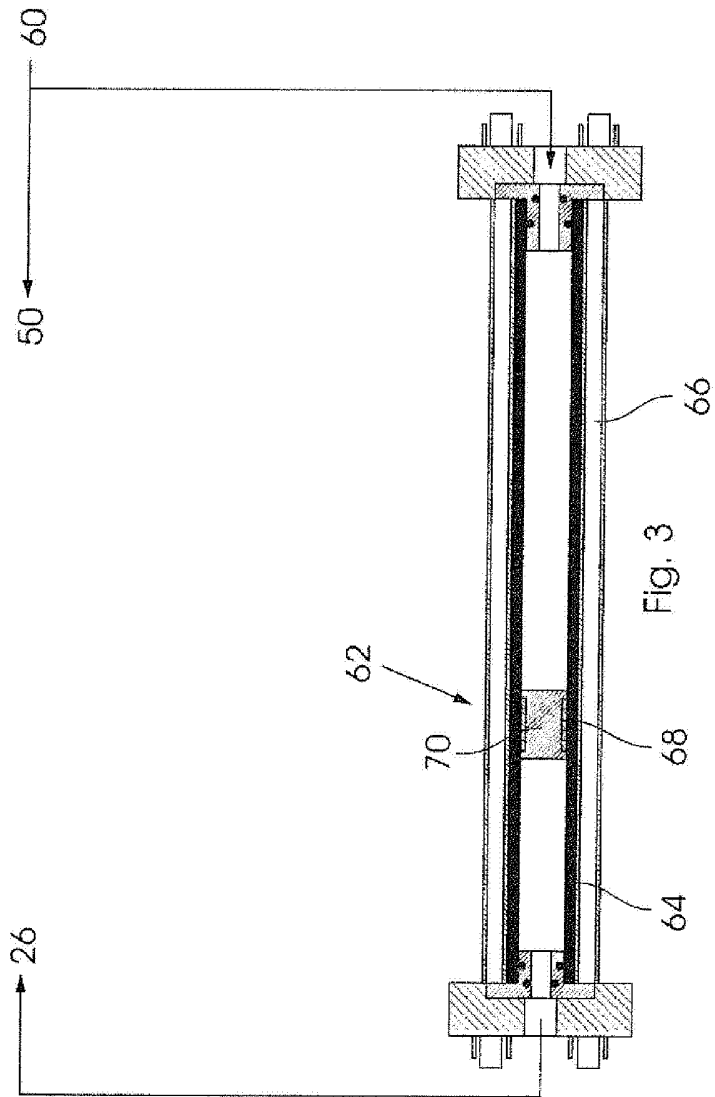

Fig. 2



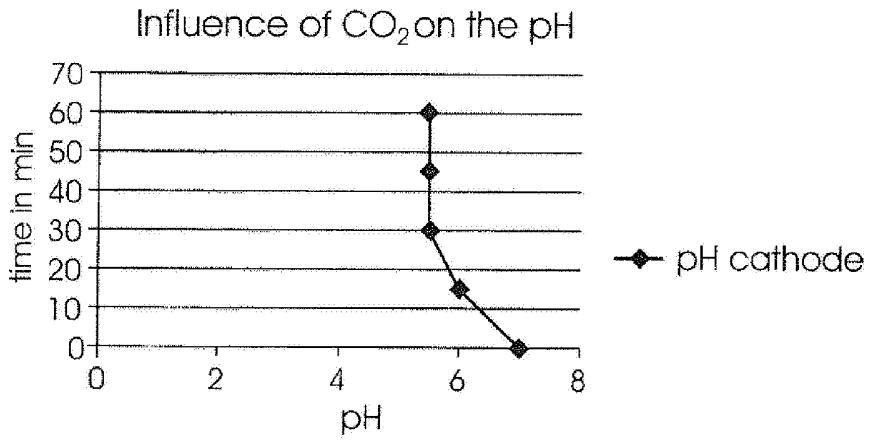

Fig. 4

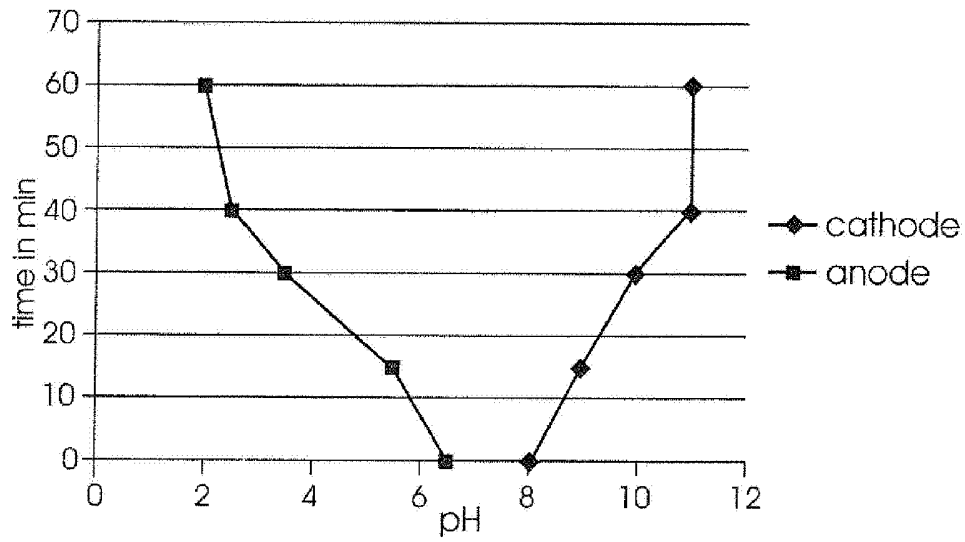

Fig. 5

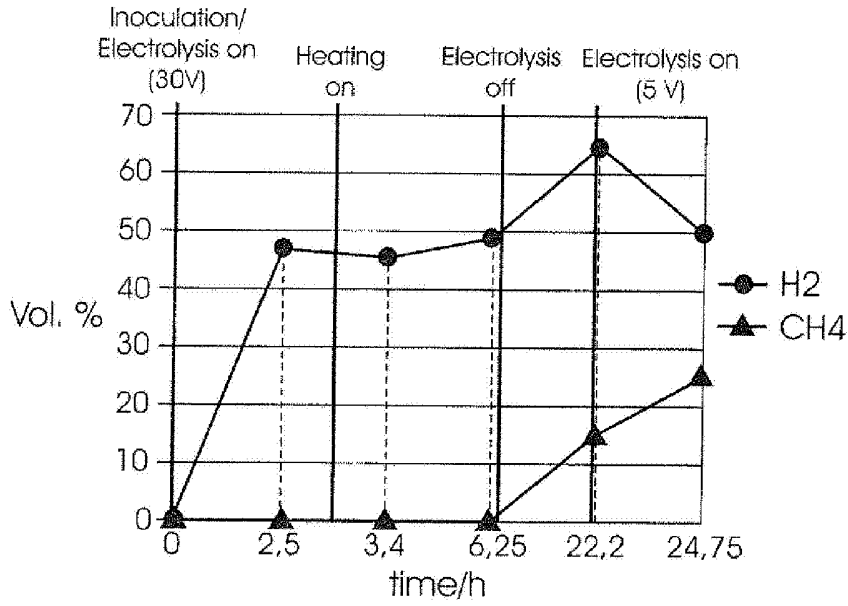

Fig. 6

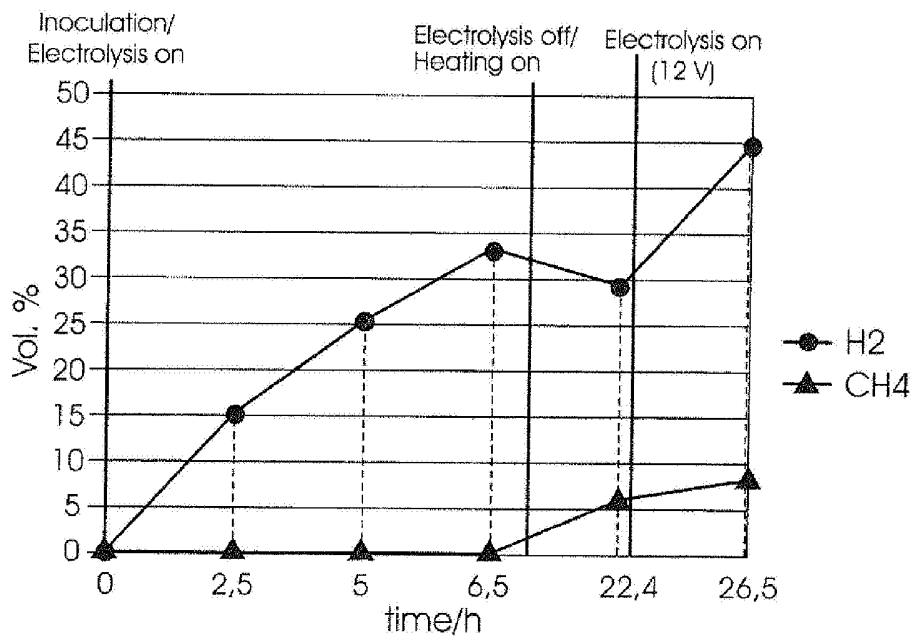

Fig. 7

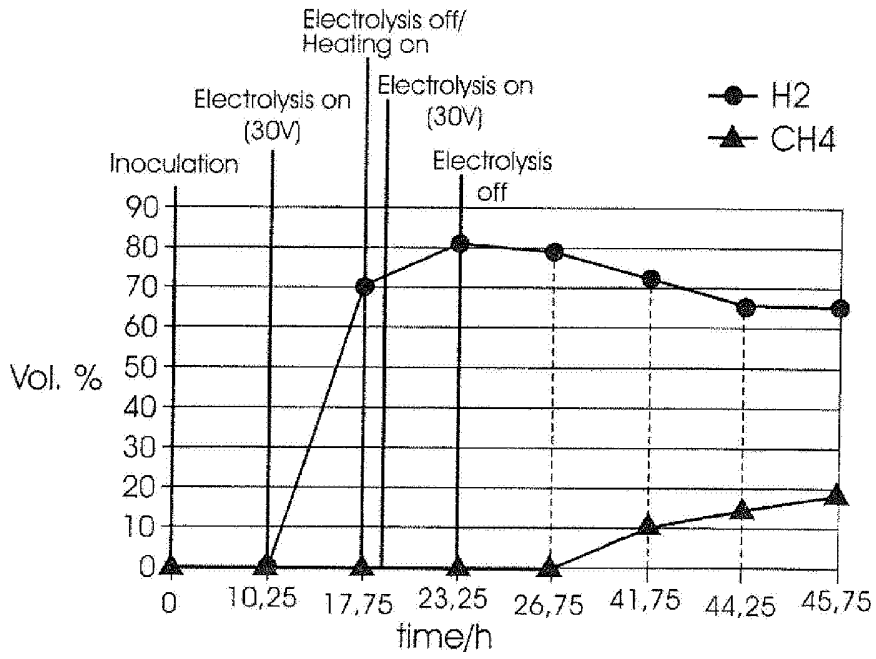

Fig. 8

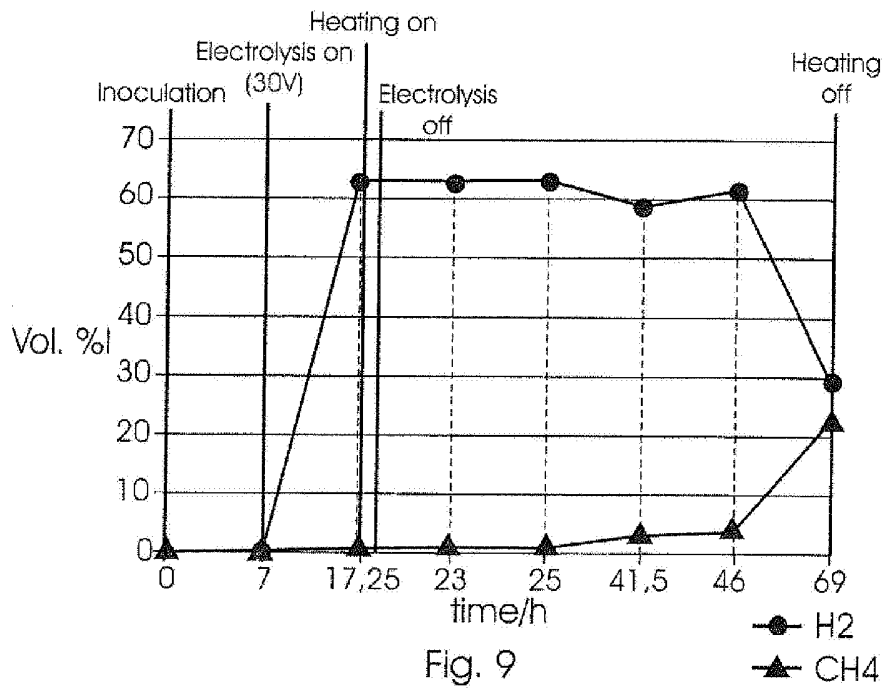

Fig. 9

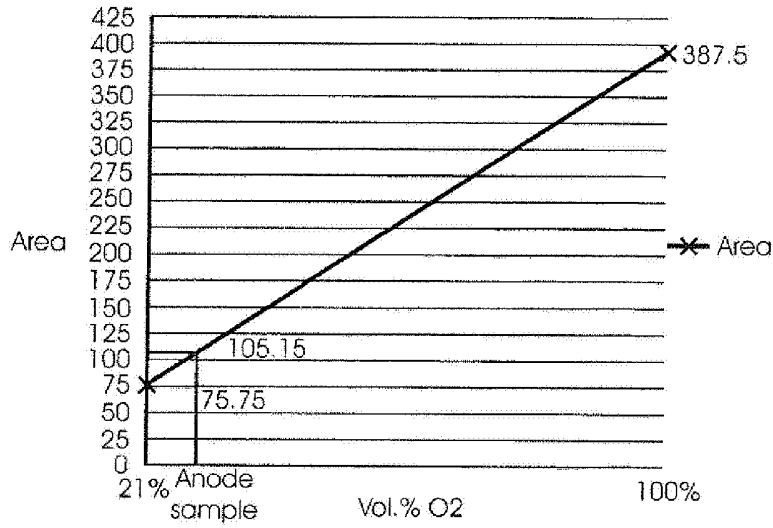

Fig. 10

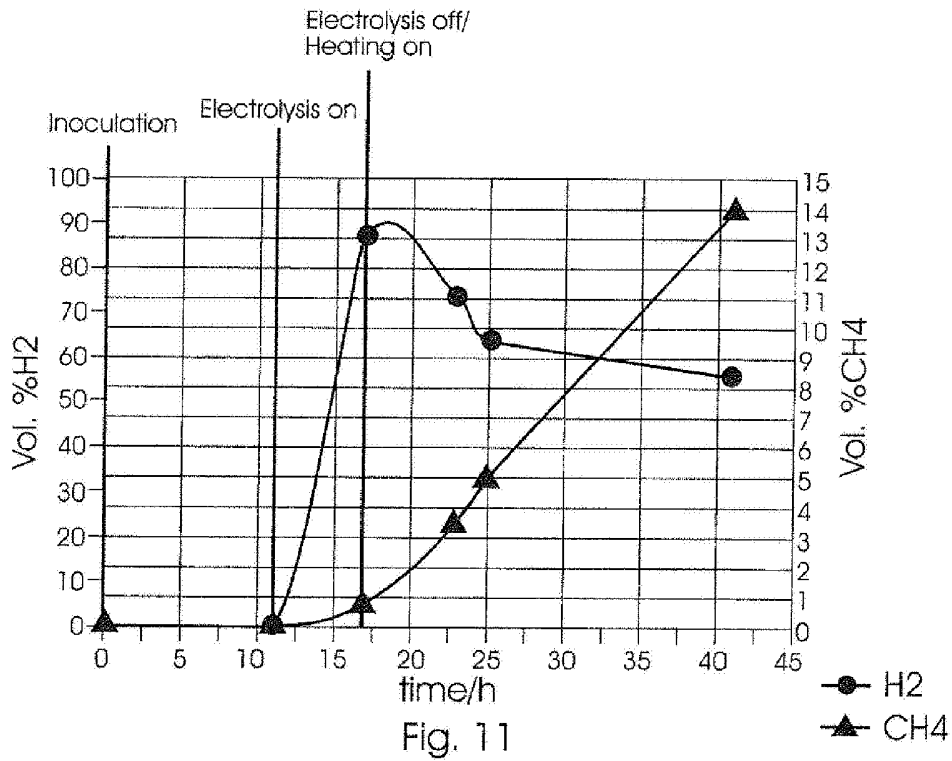

Fig. 11

