



(86) Date de dépôt PCT/PCT Filing Date: 2015/09/15
(87) Date publication PCT/PCT Publication Date: 2016/03/24
(45) Date de délivrance/Issue Date: 2021/03/16
(85) Entrée phase nationale/National Entry: 2017/02/13
(86) N° demande PCT/PCT Application No.: US 2015/050196
(87) N° publication PCT/PCT Publication No.: 2016/044279
(30) Priorité/Priority: 2014/09/15 (US62/050,562)

(51) Cl.Int./Int.Cl. *C25B 3/27* (2021.01),
C25B 3/11 (2021.01)
(72) Inventeurs/Inventors:
ALBRECHT, THOMAS A., US;
SOLAS, DENNIS, US;
LECLERC, MARGARETE K., US;
WEISS, MICHAEL JOSEPH, US;
GILLIAM, RYAN J., US;
SELF, KYLE, US
(73) Propriétaire/Owner:
CALERA CORPORATION, US
(74) Agent: GOWLING WLG (CANADA) LLP

(54) Titre : SYSTEMES ET PROCEDES ELECTROCHIMIQUES FAISANT INTERVENIR DES HALOGENURES METALLIQUES POUR FORMER DES PRODUITS

(54) Title: ELECTROCHEMICAL SYSTEMS AND METHODS USING METAL HALIDE TO FORM PRODUCTS

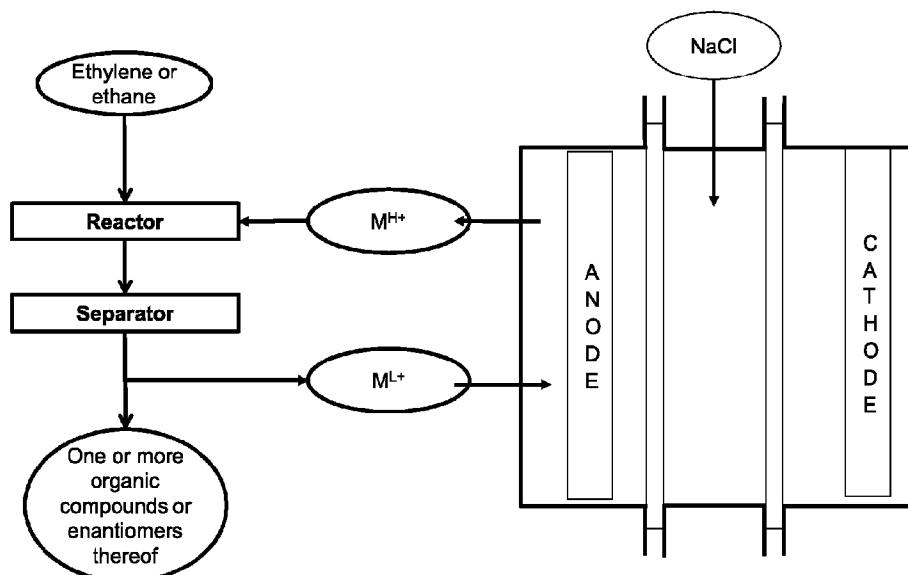

(57) Abrégé/Abstract:

There are provided electrochemical methods and systems to form one or more organic compounds or enantiomers thereof selected from the group consisting of substituted or unsubstituted dioxane, substituted or unsubstituted dioxolane, dichloroethylether, dichloromethyl methyl ether, dichloroethyl methyl ether, chloroform, carbon tetrachloride, phosgene, and combinations thereof.

(12) INTERNATIONAL APPLICATION PUBLISHED UNDER THE PATENT COOPERATION TREATY (PCT)

(19) World Intellectual Property
Organization
International Bureau(10) International Publication Number
WO 2016/044279 A1(43) International Publication Date
24 March 2016 (24.03.2016)

- (51) International Patent Classification:
H01M 8/06 (2016.01)
- (21) International Application Number:
PCT/US2015/050196
- (22) International Filing Date:
15 September 2015 (15.09.2015)
- (25) Filing Language: English
- (26) Publication Language: English
- (30) Priority Data:
62/050,562 15 September 2014 (15.09.2014) US
- (71) Applicant: CALERA CORPORATION [US/US]; 485 Alberto Way, Suite 210, Los Gatos, CA 95032 (US).
- (72) Inventors: ALBRECHT, Thomas, A.; 1111 Vasquez Avenue, Sunnyvale, CA 94086 (US). SOLAS, Dennis; 22 Sequoia Way, San Francisco, CA 94127 (US). LECLERC, Margarete, K.; 1509 Montalto Drive, Mountain View, CA 94040 (US). WEISS, Michael, Joseph; 200 Winchester Circle, Apt. C-221, Los Gatos, CA 95032 (US). GILLIAM, Ryan, J.; 5018 New Trier Avenue, San Jose, CA 95136 (US). SELF, Kyle; 5326 Baron Drive, San Jose, CA 95124 (US).
- (74) Agents: ALEMOZAFAR, Ali et al.; Wilson Sonsini Goodrich & Rosati, 650 Page Mill Road, Palo Alto, CA 94304-1050 (US).
- (81) Designated States (unless otherwise indicated, for every kind of national protection available): AE, AG, AL, AM, AO, AT, AU, AZ, BA, BB, BG, BH, BN, BR, BW, BY, BZ, CA, CH, CL, CN, CO, CR, CU, CZ, DE, DK, DM, DO, DZ, EC, EE, EG, ES, FI, GB, GD, GE, GH, GM, GT, HN, HR, HU, ID, IL, IN, IR, IS, JP, KE, KG, KN, KP, KR, KZ, LA, LC, LK, LR, LS, LU, LY, MA, MD, ME, MG, MK, MN, MW, MX, MY, MZ, NA, NG, NI, NO, NZ, OM, PA, PE, PG, PH, PL, PT, QA, RO, RS, RU, RW, SA, SC, SD, SE, SG, SK, SL, SM, ST, SV, SY, TH, TJ, TM, TN, TR, TT, TZ, UA, UG, US, UZ, VC, VN, ZA, ZM, ZW.
- (84) Designated States (unless otherwise indicated, for every kind of regional protection available): ARIPO (BW, GH, GM, KE, LR, LS, MW, MZ, NA, RW, SD, SL, ST, SZ, TZ, UG, ZM, ZW), Eurasian (AM, AZ, BY, KG, KZ, RU, TJ, TM), European (AL, AT, BE, BG, CH, CY, CZ, DE, DK, EE, ES, FI, FR, GB, GR, HR, HU, IE, IS, IT, LT, LU, LV, MC, MK, MT, NL, NO, PL, PT, RO, RS, SE, SI, SK, SM, TR), OAPI (BF, BJ, CF, CG, CI, CM, GA, GN, GQ, GW, KM, ML, MR, NE, SN, TD, TG).

Published:

— with international search report (Art. 21(3))

(54) Title: ELECTROCHEMICAL SYSTEMS AND METHODS USING METAL HALIDE TO FORM PRODUCTS

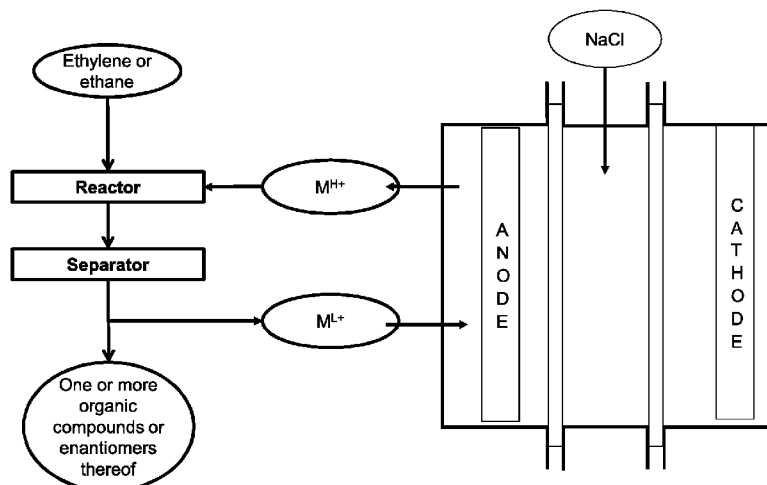

FIGURE 1

(57) Abstract: There are provided electrochemical methods and systems to form one or more organic compounds or enantiomers thereof selected from the group consisting of substituted or unsubstituted dioxane, substituted or unsubstituted dioxolane, dichloro-ethylether, dichloromethyl methyl ether, dichloroethyl methyl ether, chloroform, carbon tetrachloride, phosgene, and combinations thereof.

WO 2016/044279 A1

ELECTROCHEMICAL SYSTEMS AND METHODS USING METAL HALIDE TO FORM PRODUCTS

[01]

GOVERNMENT SUPPORT

[02] Work described herein was made in whole or in part with Government support under Award Number: DE-FE0002472 awarded by the Department of Energy. The Government has certain rights in this invention.

BACKGROUND

[03] Ethylene dichloride may be made by direct chlorination of ethylene using chlorine gas made from the chlor-alkali process. In producing the caustic soda electrochemically, such as via chlor-alkali process, a large amount of energy, salt, and water is used.

[04] The production of chlorine and caustic soda by electrolysis of aqueous solutions of sodium chloride or brine is one of the electrochemical processes demanding high-energy consumption. The total energy requirement is for instance about 2% in the USA and about 1% in Japan of the gross electric power generated, to maintain this process by the chlor-alkali industry. The high energy consumption may be related to high carbon dioxide emission owing to burning of fossil fuels. Therefore, reduction in the electrical power demand needs to be addressed to curtail environment pollution and global warming. There is a need to produce chemicals by low energy consumption.

SUMMARY

[05] In one aspect, there is provided a method comprising contacting an anode with an anode electrolyte wherein the anode electrolyte comprises saltwater and metal halide; applying a voltage to the anode and cathode and oxidizing the metal halide from a lower oxidation state to a higher oxidation state at the anode; contacting the cathode with a cathode electrolyte; and halogenating ethylene or ethane with the anode electrolyte comprising the saltwater and the metal halide in the higher oxidation state, in an aqueous medium wherein the aqueous medium comprises more than 5wt% water to form one or more organic compounds or enantiomers thereof and the metal halide in the lower oxidation state, wherein the one or more organic compounds or enantiomers thereof are selected from the group

consisting of substituted or unsubstituted dioxane, substituted or unsubstituted dioxolane, dichloroethylether, dichloromethyl methyl ether, dichloroethyl methyl ether, chloroform, carbon tetrachloride, phosgene, and combinations thereof.

[06] In some embodiments of the foregoing aspect, the saltwater comprises water comprising alkali metal ions or alkaline earth metal ions.

[07] In some embodiments of the foregoing aspect and embodiment, the method further comprises forming chloroethanol in more than 20wt% yield from the halogenation of ethylene or ethane under one or more reaction conditions selected from temperature of halogenation mixture between about 120-160°C; incubation time of between about 10min-2hour; total halide concentration in the halogenation mixture between about 7-12M, catalysis with noble metal, and combinations thereof, and using the chloroethanol to form the one or more organic compounds or enantiomers thereof selected from substituted or unsubstituted dioxane, substituted or unsubstituted dioxolane, dichloroethylether, dichloromethyl methyl ether, dichloroethyl methyl ether, chloroform, carbon tetrachloride, phosgene, and combinations thereof. In some embodiments of the foregoing aspect and embodiments, the chloroethanol is formed in more than 40 wt% yield.

[08] In the foregoing embodiment, the noble metals are selected from ruthenium, rhodium, palladium, silver, osmium, iridium, platinum, gold, mercury, rhenium, titanium, niobium, tantalum, and combinations thereof. In some embodiments, the foregoing noble metals are supported on a solid. In some embodiments, the foregoing noble metals are supported on carbon.

[09] In some embodiments of the foregoing aspect and embodiments, the method further comprises forming trichloroacetaldehyde (TCA) in more than 20wt% yield from the halogenation of ethylene or ethane under one or more reaction conditions selected from temperature of halogenation mixture between about 160-200°C; incubation time of between about 15min-2hour; concentration of the metal halide in the higher oxidation state at more than 4.5M, and combinations thereof, and using the TCA to form the one or more organic compounds or enantiomers thereof selected from the group consisting of substituted or unsubstituted dioxane, substituted or unsubstituted dioxolane, dichloroethylether, dichloromethyl methyl ether, dichloroethyl methyl ether, chloroform, carbon tetrachloride, phosgene, and combinations thereof. In some embodiments of the foregoing aspect and embodiments, TCA is formed in more than 40wt% yield.

[10] In some embodiments of the foregoing aspect and embodiments, total amount of chloride content in the anode electrolyte is between 6-15M.

[11] In some embodiments of the foregoing aspect and embodiments, the saltwater comprises sodium chloride and the anode electrolyte comprises metal halide in the higher oxidation state in range of 4-8M, metal halide in the lower oxidation state in range of 0.1-2M and sodium chloride in range of 1-5M.

[12] In some embodiments of the foregoing aspect and embodiments, the method further comprises forming an alkali, water, or hydrogen gas at the cathode. In some embodiments of the foregoing aspect and embodiments, the cathode electrolyte comprises water and the cathode is an oxygen depolarizing cathode that reduces oxygen and water to hydroxide ions; the cathode electrolyte comprises water and the cathode is a hydrogen gas producing cathode that reduces water to hydrogen gas and hydroxide ions; the cathode electrolyte comprises hydrochloric acid and the cathode is a hydrogen gas producing cathode that reduces hydrochloric acid to hydrogen gas; or the cathode electrolyte comprises hydrochloric acid and the cathode is an oxygen depolarizing cathode that reacts hydrochloric acid and oxygen gas to form water.

[13] In some embodiments of the foregoing aspect and embodiments, metal ion in the metal halide is selected from the group consisting of iron, chromium, copper, tin, silver, cobalt, uranium, lead, mercury, vanadium, bismuth, titanium, ruthenium, osmium, europium, zinc, cadmium, gold, nickel, palladium, platinum, rhodium, iridium, manganese, technetium, rhenium, molybdenum, tungsten, niobium, tantalum, zirconium, hafnium, and combination thereof. In some embodiments of the foregoing aspect and embodiments, metal ion in the metal halide is selected from the group consisting of iron, chromium, copper, and tin. In some embodiments of the foregoing aspect and embodiments, the metal halide is copper chloride. In some embodiments of the foregoing aspect and embodiments, the lower oxidation state of metal ion in the metal halide is 1+, 2+, 3+, 4+, or 5+. In some embodiments of the foregoing aspect and embodiments, the higher oxidation state of metal ion in the metal halide is 2+, 3+, 4+, 5+, or 6+. In some embodiments of the foregoing aspect and embodiments, metal ion in the metal halide is copper that is converted from Cu^+ to Cu^{2+} , metal ion in the metal halide is iron that is converted from Fe^{2+} to Fe^{3+} , metal ion in the metal halide is tin that is converted from Sn^{2+} to Sn^{4+} , metal ion in the metal halide is chromium that is converted from Cr^{2+} to Cr^{3+} , metal ion in the metal halide is platinum that is converted from Pt^{2+} to Pt^{4+} , or combination thereof.

[14] In some embodiments of the foregoing aspect and embodiments, no gas is used or formed at the anode.

[15] In some embodiments of the foregoing aspect and embodiments, the method further comprises adding a ligand to the anode electrolyte wherein the ligand interacts with the metal halide.

[16] In some embodiments of the foregoing aspect and embodiments, the metal halide in the lower oxidation state is re-circulated back to the anode electrolyte.

[17] In some embodiments of the foregoing aspect and embodiments, the anode electrolyte comprising the metal halide in the higher oxidation state further comprises the metal halide in the lower oxidation state.

[18] In another aspect, there is provided a system comprising:

an electrochemical system comprising an anode chamber comprising an anode in contact with an anode electrolyte, wherein the anode electrolyte comprises saltwater and metal halide, wherein the anode is configured to oxidize the metal halide from a lower oxidation state to a higher oxidation state; and a cathode chamber comprising a cathode in contact with a cathode electrolyte;

a first reactor operably connected to the anode chamber and configured to react ethylene or ethane with the anode electrolyte comprising the saltwater and the metal halide in the higher oxidation state to form more than 20 wt% CE wherein the reactor is configured to provide one or more reaction conditions selected from temperature of reaction mixture between about 120-160°C; incubation time of between about 10min-2hour; total halide concentration in the reaction mixture between about 6-12M, catalysis with noble metal, and combinations thereof; and/or to form more than 20 wt% TCA wherein the reactor is configured to provide one or more reaction conditions selected from temperature of halogenation mixture between about 160-200°C; incubation time of between about 15min-2hour; concentration of the metal halide in the higher oxidation state at more than 4.5M, and combinations thereof, and

a second reactor operably connected to the first reactor and configured to form the one or more organic compounds or enantiomers thereof selected from the group consisting of substituted or unsubstituted dioxane, substituted or unsubstituted dioxolane, dichloroethylether, dichloromethyl methyl ether, dichloroethyl methyl ether, chloroform, carbon tetrachloride, phosgene, and combinations thereof, from the CE or TCA.

BRIEF DESCRIPTION OF THE DRAWINGS

[19] The novel features of the invention are set forth with particularity in the appended claims. A better understanding of the features and advantages of the present invention may

be obtained by reference to the following detailed description that sets forth illustrative embodiments, in which the principles of the invention are utilized, and the accompanying drawings of which:

[20] **Fig. 1** is an illustration of some embodiments related to the electrochemical system, reactor system, and the separation system.

[21] **Fig. 2** is an illustration of some embodiments related to the formation of the one or more organic compounds.

[22] **Fig. 3** is an illustration of some embodiments of the electrochemical system.

[23] **Fig. 4** is an illustration of some embodiments of the electrochemical system.

[24] **Figs. 5A and 5B** are an illustration of some embodiments related to the ion exchange membranes.

[25] **Fig. 6** illustrates few examples of the diffusion enhancing anode such as, the porous anode, as described herein.

[26] **Fig. 7** is an illustration of some embodiments related to Example 2.

[27] **Fig. 8** is an illustration of some embodiments related to Example 3.

[28] **Fig. 9** is an illustration of some embodiments related to Example 3.

[29] **Fig. 10** is an illustration of GCMS chromatograms related to Example 4.

[30] **Fig. 11** is an illustration of GCMS chromatograms related to Example 4.

DETAILED DESCRIPTION

[31] Disclosed herein are systems and methods that relate to the oxidation of a metal halide by the anode in the anode chamber where the metal halide is oxidized from the lower oxidation state to a higher oxidation state. The metal halide in the higher oxidation state is then reacted with ethylene or ethane to form one or more organic compounds or enantiomers thereof.

[32] As can be appreciated by one ordinarily skilled in the art, the present electrochemical system and method can be configured with an alternative, equivalent salt solution, e.g., a potassium chloride solution or sodium chloride solution or a magnesium chloride solution or calcium chloride solution or sodium sulfate solution or ammonium chloride solution, to produce an equivalent alkaline solution, e.g., potassium hydroxide or sodium hydroxide or magnesium hydroxide in the cathode electrolyte (or other reactions at the cathode described herein). Accordingly, to the extent that such equivalents are based on or suggested by the present system and method, these equivalents are within the scope of the application.

[33] Before the present invention is described in greater detail, it is to be understood that this invention is not limited to particular embodiments described, as such may, of course, vary. It is also to be understood that the terminology used herein is for the purpose of describing particular embodiments only, and is not intended to be limiting, since the scope of the present invention will be limited only by the appended claims.

[34] Where a range of values is provided, it is understood that each intervening value, to the tenth of the unit of the lower limit unless the context clearly dictates otherwise, between the upper and lower limit of that range and any other stated or intervening value in that stated range, is encompassed within the invention. The upper and lower limits of these smaller ranges may independently be included in the smaller ranges and are also encompassed within the invention, subject to any specifically excluded limit in the stated range. Where the stated range includes one or both of the limits, ranges excluding either or both of those included limits are also included in the invention.

[35] Certain ranges that are presented herein with numerical values may be construed as “about” numerals. The “about” is to provide literal support for the exact number that it precedes, as well as a number that is near to or approximately the number that the term precedes. In determining whether a number is near to or approximately a specifically recited number, the near or approximating unrecited number may be a number, which, in the context in which it is presented, provides the substantial equivalent of the specifically recited number.

[36] Unless defined otherwise, all technical and scientific terms used herein have the same meaning as commonly understood by one of ordinary skill in the art to which this invention belongs. Although any methods and materials similar or equivalent to those described herein can also be used in the practice or testing of the present invention, representative illustrative methods and materials are now described.

[37]

The citation of any publication is for its disclosure prior to the filing date and should not be construed as an admission that the present invention is not entitled to antedate such publication by virtue of prior invention. Further, the dates of publication provided may be different from the actual publication dates which may need to be independently confirmed.

[38] It is noted that, as used herein and in the appended claims, the singular forms "a," "an," and "the" include plural references unless the context clearly dictates otherwise. It is further noted that the claims may be drafted to exclude any optional element. As such, this statement is intended to serve as antecedent basis for use of such exclusive terminology as "solely," "only" and the like in connection with the recitation of claim elements, or use of a "negative" limitation.

[39] As will be apparent to those of skill in the art upon reading this disclosure, each of the individual embodiments described and illustrated herein has discrete components and features which may be readily separated from or combined with the features of any of the other several embodiments without departing from the scope or spirit of the present invention. Any recited method can be carried out in the order of events recited or in any other order which is logically possible.

Methods and Systems

[40] There are provided methods and systems that relate to the oxidation of metal ions, such as, metal halides, from a lower oxidation state to a higher oxidation state in the anode chamber of the electrochemical cell; use of the metal ion in the higher oxidation state for the generation of one or more organic compounds or enantiomers thereof by reaction with hydrocarbons such as, but not limited to, ethylene or ethane; separation/purification of the one or more organic compounds or enantiomers thereof from the metal ion solution; and recycling of the metal ion solution back to the electrochemical cell. In one aspect, the electrochemical cells described herein provide an efficient and low voltage system where the metal compound such as metal halide, e.g., metal chloride with the metal ion in the higher oxidation state produced by the anode can be used for purposes, such as, but not limited to, generation of one or more organic compounds or enantiomers thereof from ethylene or ethane in high yield and selectivity. The one or more organic compounds or enantiomers thereof are, but not limited to, substituted or unsubstituted dioxane, substituted or unsubstituted dioxolane, dichloroethylether, dichloromethyl methyl ether, dichloroethyl methyl ether, chloroform, carbon tetrachloride, phosgene, and combinations thereof.

[41] In one aspect, there are provided methods that include contacting an anode with an anode electrolyte in an anode chamber wherein the anode electrolyte comprises saltwater and metal halide; applying a voltage to the anode and cathode and oxidizing the metal halide from a lower oxidation state to a higher oxidation state at the anode; contacting the cathode with a cathode electrolyte; and halogenating ethylene or ethane with the anode electrolyte

comprising the saltwater and the metal halide in the higher oxidation state, in an aqueous medium wherein the aqueous medium comprises more than 5wt% water to form one or more organic compounds or enantiomers thereof and the metal halide in the lower oxidation state, wherein the one or more organic compounds or enantiomers thereof are selected from the group consisting of substituted or unsubstituted dioxane, substituted or unsubstituted dioxolane, dichloroethylether, dichloromethyl methyl ether, dichloroethyl methyl ether, chloroform, carbon tetrachloride, phosgene, and combinations thereof. In some embodiments of the foregoing aspect, the method further comprises separating and/or purifying the one or more organic compounds or enantiomers thereof from the metal halide solution. In some embodiments, the separated metal halide solution comprising metal halide in the lower oxidation state and optionally comprising metal halide in the higher oxidation state are recirculated back to the anode electrolyte.

[42] In some embodiments, there are provided systems that carry out the methods described herein. In some embodiments, there are provided systems that include an anode chamber comprising an anode in contact with a metal halide and saltwater in an anode electrolyte, wherein the anode is configured to oxidize the metal halide from a lower oxidation state to a higher oxidation state; and a cathode chamber comprising a cathode in contact with a cathode electrolyte wherein the cathode is configured to form an alkali, water, and/or hydrogen gas in the cathode electrolyte; and a reactor operably connected to the anode chamber and configured to contact the anode electrolyte comprising saltwater and metal halide in the higher oxidation state with ethylene or ethane to form one or more organic compounds or enantiomers thereof and the metal halide in the lower oxidation state in an aqueous medium wherein the aqueous medium comprises more than 5wt% water; wherein the one or more organic compounds or enantiomers thereof are selected from the group consisting of substituted or unsubstituted dioxane, substituted or unsubstituted dioxolane, dichloroethylether, dichloromethyl methyl ether, dichloroethyl methyl ether, chloroform, carbon tetrachloride, phosgene, and combinations thereof. In some embodiments, the system further comprises a separator to separate and/or purify the one or more organic compounds or enantiomers thereof from the metal halide solution. In some embodiments, the system further comprises a recirculation system to recirculate the separated metal halide solution comprising metal halide in the lower oxidation state and optionally comprising metal halide in the higher oxidation state, back to the anode electrolyte.

[43] An illustration of an electrochemical system producing the anode electrolyte with metal halide in the higher oxidation state integrated with a reactor system for generation of

one or more organic compounds or enantiomers thereof from ethylene or ethane and from the metal halide in the higher oxidation state; further the reactor system integrated with the separator system to separate the one or more organic compounds or enantiomers thereof from the metal halide solution; and furthermore the recirculation of the metal halide in the lower oxidation state back to the electrochemical system, is shown in **Fig. 1**. The electrochemical system of **Fig. 1** includes an anode and a cathode separated by anion exchange membrane and cation exchange membrane creating a third chamber containing a third electrolyte, NaCl. The anode chamber includes the anode and an anode electrolyte in contact with the anode. The cathode chamber includes the cathode and a cathode electrolyte in contact with the cathode. The metal ion or the metal halide is oxidized in the anode chamber from the lower oxidation state M^{L+} to the higher oxidation state M^{H+} which metal in the higher oxidation state is then used for reactions in a reactor, such as reaction with hydrocarbon, such as, ethylene or ethane to produce one or more organic compounds or enantiomers thereof. The metal ion in the higher oxidation state is consequently reduced to metal ion in the lower oxidation state. The metal ion solution is separated from the one or more organic compounds or enantiomers thereof (organics) in a separator before the metal ion solution is recirculated back to the anode electrolyte of the electrochemical system. It is to be understood that the metal halide solution going into the anode electrolyte and the metal halide solution coming out of the anode electrolyte contains a mix of the metal halide in the lower oxidation state and the higher oxidation state except that the metal halide solution coming out of the anode chamber has higher amount of metal halide in the higher oxidation state than the metal halide solution going into the anode electrolyte.

[44] The electrochemical systems, reactor systems, separator systems, and products formed by such reactions are described herein. It is to be understood that the system of **Fig. 1** is for illustration purposes only and metal ions with different oxidations states (e.g., chromium, tin etc.); other electrochemical systems described herein; the third electrolyte other than sodium chloride such as other sodium halides or halides of alkali metal ions or alkaline earth metal ions; and cathodes producing hydroxide, water and/or hydrogen gas, are variations that are applicable to this system. It is also to be understood that the reactor may be a combination of one or more reactors and the separator may be a combination of one or more separators or separation units. The reactors and the separators have been described herein in detail. The reactors and the separator systems are configured with inlets and outlets in the form of tubes or conduits for the flow of liquids in and out of the systems.

[45] In some embodiments, the metal compound produced by the anode chamber may be used as is or may be purified before reacting with ethylene or ethane for the generation of the one or more organic compounds or enantiomers thereof. For example, in some embodiments, the metal compound/solution in the higher oxidation state is treated with the ethylene gas to form the one or more organic compounds or enantiomers thereof, such as, substituted or unsubstituted dioxane, substituted or unsubstituted dioxolane, dichloroethylether, dichloromethyl methyl ether, dichloroethyl methyl ether, chloroform, carbon tetrachloride, phosgene, and combinations thereof.

[46] In the systems and methods provided herein the metal ion solutions may be separated and/or purified before and after the reaction in the reactor. Similarly, the products made in the reactor may also be subjected to organic separation and/or purification before their commercial use. In the methods and systems provided herein, the separation and/or purification may include one or more of the separation and purification of the organic compounds from the metal ion solution; the separation and purification of the organic compounds from each other; and separation and purification of the metal ion in the lower oxidation state from the metal ion in the higher oxidation state, to improve the overall yield of the organic product, improve selectivity of the organic product, improve purity of the organic product, improve efficiency of the systems, improve ease of use of the solutions in the overall process, improve reuse of the metal solution in the electrochemical and reaction process, and to improve the overall economics of the process.

[47] In the embodiments provided herein, the one or more organic compounds or enantiomers thereof produced in accordance with the methods and systems of the invention include substituted or unsubstituted dioxane, substituted or unsubstituted dioxolane, dichloroethylether, dichloromethyl methyl ether, dichloroethyl methyl ether, chloroform, carbon tetrachloride, phosgene, and combinations thereof. The "enantiomers thereof" as used herein includes chiral molecules or mirror images of the one or more organic compounds. The enantiomers are conventionally known in the art.

[48] These one or more organic compounds or enantiomers thereof are made from ethylene or ethane by halogenation reaction with metal halide in the higher oxidation state. Applicants found that these one or more organic compounds or enantiomers thereof could be formed by the chlorination of the ethylene or ethane irrespective of the halide's presence in the one or more organic compounds. Applicants also found that these one or more organic compounds or enantiomers thereof could be formed through the controlled formation of series of intermediates by controlling one or more reaction conditions in order to

predominantly form one intermediate over the other. These intermediates and the controlled reaction conditions are as described herein.

[49] For example, the halogenation of ethylene or ethane may result first in the formation of ethylene dichloride (EDC) (also be known as 1,2-dichloroethane, dichloroethane, 1,2-ethylene dichloride, glycol dichloride, etc). The EDC may undergo reactions to form series of intermediates such as chloroethanol (CE or 2-chloroethanol), monochloroacetaldehyde (MCA), dichloroacetaldehyde (DCA), trichloroacetaldehyde (TCA), etc. However, these series of compounds such as, CE, TCA, DCA, or MCA may be formed directly from ethylene or ethane without the intermediate formation of EDC. Applicants have found that a specific set of controlled reaction conditions can result in the formation of CE or TCA by halogenation reaction of ethylene or ethane with metal halide in the higher oxidation state. The CE or TCA then can be used to further form the one or more organic compounds or enantiomers thereof including, substituted or unsubstituted dioxane, substituted or unsubstituted dioxolane, dichloroethylether, dichloromethyl methyl ether, dichloroethyl methyl ether, chloroform, carbon tetrachloride, phosgene, and combinations thereof.

[50] The above noted compounds are illustrated in **Fig. 2**. As demonstrated in **Fig. 2**, the ethylene or ethane after reaction with the metal halide in the higher oxidation state results in the formation of EDC. The formation of EDC has been described in US Patent Application Serial No. 13/474,598, filed May 17, 2012 .

For example, the EDC is produced via a reaction with ethylene and copper(II) chloride as follows:



[51] Ethylene may be supplied under pressure in the gas phase and metal halide, for example only, copper(II) chloride (also containing copper(I) chloride) is supplied in an aqueous solution originating from the outlet of the anode chamber of the electrochemical cell. The reaction may occur in the liquid phase where the dissolved ethylene reacts with the copper(II) chloride. The reaction may be carried out at pressures between 270 psig and 530 psig to improve ethylene solubility in the aqueous phase. Since the reaction takes place in the aqueous medium, the EDC can further react with the water to form 2-chloroethanol (CE):



[52] While CE may be formed in small amounts, Applicants have found that in order to form higher amounts of CE, certain reactions conditions may be controlled and used such that the CE is formed in higher amounts. For example, the temperature of the reaction may be

operated above 120°C; or between about 120-200°C; or between about 120-190°C; or between about 120-180°C; or between about 120-170°C; or between about 120-160°C; or between about 120-150°C; or between about 120-140°C; or between about 120-130°C; or between about 130-200°C; or between about 130-190°C; or between about 130-180°C; or between about 130-170°C; or between about 130-160°C; or between about 130-150°C; or between about 130-140°C; or between about 140-200°C; or between about 140-190°C; or between about 140-180°C; or between about 140-170°C; or between about 140-160°C; or between about 140-150°C; or between about 150-200°C; or between about 150-190°C; or between about 150-180°C; or between about 150-170°C; or between about 150-160°C; or between about 160-200°C; or between about 160-190°C; or between about 160-180°C; or between about 160-170°C; or between about 170-200°C; or between about 170-190°C; or between about 170-180°C; or between about 180-200°C; or between about 180-190°C; or between about 190-200°C. In some embodiments, the temperatures noted above produce chloroethanol in more than 20wt% yield or higher yields as noted below.

[53] It was further noted that the CE formation may be increased by varying the total chloride concentration in the halogenations mixture. The “halogenations mixture” or the “reaction mixture” as used herein includes a reaction mixture that contains the ethylene or ethane and the metal halide in the higher oxidation state (also containing metal halide in the lower oxidation state) in an aqueous medium. The “total halide concentration” or the “total chloride concentration” as used herein includes the total concentration of the halide, such as, fluoride, bromide, iodide or the chloride from the metal halide in the higher oxidation state, the metal halide in the lower oxidation state and the halide in the saltwater, such as sodium chloride. In some embodiments, the total halide concentration in the halogenation mixture is between about 6-15M to produce chloroethanol in more than 20wt% yield or higher yields as noted below. In some embodiments, the total halide concentration in the halogenation mixture is between about 6-13M; or between about 6-12M; or between about 6-11M; or between about 6-10M; or between about 6-9M; or between about 6-8M; or between about 6-7M; or between about 7-13M; or between about 7-12M; or between about 7-11M; or between about 7-10M; or between about 7-9M; or between about 7-8M; or between about 8-13M; or between about 8-12M; or between about 8-11M; or between about 8-10M; or between about 8-9M; or between about 9-13M; or between about 9-12M; or between about 9-11M; or between about 9-10M; or between about 10-13M; or between about 10-12M; or between

about 10-11M; or between about 11-13M; or between about 11-12M; or between about 12-13M.

[54] It was also noted that the CE formation may be increased by varying the incubation time of the halogenations mixture. The “incubation time” as used herein includes the time period for which the halogenations mixture is left in the reactor at the above noted temperatures before being taken out for the separation of the product. In some embodiments, the incubation time for the halogenations mixture is between about 10min-10hour or more depending on the temperature of the halogenations mixture. This incubation time may be in combination with the above noted temperature ranges and/or above noted total chloride concentrations. In some embodiments, the incubation time for the halogenations mixture is between about 10min-3hour; or between about 10min-2.5hour; or between about 10min-2hour; or between about 10min-1.5hour; or between about 10min-1hour; or between about 10min-30min; or between about 20min-3hour; or between about 20min-2hour; or between about 20min-1hour; or between about 30min-3hour; or between about 30min-2hour; or between about 30min-1hour; or between about 1hour-2hour; or between about 1hour-3hour; or between about 2hour-3hour, to form CE in more than 20wt% or higher yields as noted below.

[55] The effect of temperature, incubation time and total halide concentration on the formation and yield of CE can be seen in Example 3 herein.

[56] It was further found that the CE formation may be increased by carrying out the halogenations in the presence of a noble metal. The “noble metal” as used herein includes metals that are resistant to corrosion in moist conditions. In some embodiments, the noble metals are selected from ruthenium, rhodium, palladium, silver, osmium, iridium, platinum, gold, mercury, rhenium, titanium, niobium, tantalum, and combinations thereof. In some embodiments, the noble metal is selected from rhodium, palladium, silver, platinum, gold, titanium, niobium, tantalum, and combinations thereof. In some embodiments, the noble metal is palladium, platinum, titanium, niobium, tantalum, or combinations thereof. In some embodiments, the foregoing noble metal is supported on a solid. Examples of solid support include, without limitation, carbon, zeolite, titanium dioxide, alumina, silica, and the like. In some embodiments, the foregoing noble metal is supported on carbon. For example only, the catalyst is palladium over carbon. The amount of noble metal used in the halogenation reaction is between 0.001M to 2M; or between 0.001-1.5M; or between about 0.001-1M; or between about 0.001-0.5M; or between about 0.001-0.05M; or between 0.01-2M; or between 0.01-1.5M; or between 0.01-1M; or between 0.01-0.5M; or between 0.1-2M; or between 0.1-

1.5M; or between 0.1-1M; or between 0.1-0.5M; or between 1-2M. The effect of noble metal catalyst on the formation and yield of CE can be seen in Example 2 herein.

[57] The yield of CE by using the reaction conditions noted above includes more than 20wt% or more than 30wt% or more than 40wt% or more than 50wt% of CE formed by the reaction of the ethylene or ethane with the metal halide in the higher oxidation state. The yield of the CE formed using the reaction conditions described herein include, but not limited to, more than 20wt% CE; more than 30wt% CE; more than 40wt% CE; more than 50wt% CE; or more than 60wt% CE; or more than 70wt% CE; or more than 75wt% CE; or more than 80wt% CE; or more than 85wt% CE; or more than 90wt% CE; or more than 95wt% CE; or between about 20-99wt% CE; or between about 20-90wt% CE; or between about 20-75wt% CE; or between about 20-60wt% CE; or between about 20-50wt% CE; or between about 30-99wt% CE; or between about 30-90wt% CE; or between about 30-75wt% CE; or between about 30-60wt% CE; or between about 30-50wt% CE; or between about 40-99wt% CE; or between about 40-90wt% CE; or between about 40-75wt% CE; or between about 40-60wt% CE; or between about 40-50wt% CE; or between about 50-99wt% CE; or between about 50-95wt% CE; or between about 50-90wt% CE; or between about 50-80% CE; or between about 50-70wt% CE; or between about 50-60wt% CE; or between about 60-99wt% CE; or between about 60-90wt% CE; or between about 60-80wt% CE; or between about 60-70wt% CE; or between about 70-99wt% CE; or between about 70-90wt% CE; or between about 70-80wt% CE; or between about 80-99wt% CE; or between about 80-90wt% CE; or between about 90-99wt% CE. These yields of CE may be obtained by one or more reaction conditions selected from the temperature of halogenation mixture between about 120-160°C; the incubation time of between about 10min-2hour; the total halide concentration in the halogenation mixture between about 7-12M, the catalysis with noble metal, and combinations thereof. The temperature ranges may be combined with the incubation time and/or with the total chloride concentration ranges and/or catalysis with noble metal in order to form the above noted yields.

[58] Accordingly, in some embodiments, there is provided a method, comprising contacting an anode with an anode electrolyte wherein the anode electrolyte comprises saltwater and metal halide; applying a voltage to the anode and cathode and oxidizing the metal halide from a lower oxidation state to a higher oxidation state at the anode; contacting the cathode with a cathode electrolyte;

halogenating ethylene or ethane with the anode electrolyte comprising the saltwater and the metal halide in the higher oxidation state, in an aqueous medium wherein the aqueous

medium comprises more than 5wt% water to form chloroethanol in more than 20wt% yield under one or more reaction conditions selected from temperature of halogenation mixture between about 120-160°C; incubation time of between about 10min-2hour; total halide concentration in the halogenation mixture between about 7-12M, catalysis with noble metal, and combinations thereof, and the metal halide in the lower oxidation state, and

using the chloroethanol to form one or more organic compounds or enantiomers thereof, wherein the one or more organic compounds or enantiomers thereof are selected from the group consisting of substituted or unsubstituted dioxane, substituted or unsubstituted dioxolane, dichloroethylether, dichloromethyl methyl ether, dichloroethyl methyl ether, chloroform, carbon tetrachloride, phosgene, and combinations thereof.

[59] In some embodiments, there is provided a method, comprising contacting an anode with an anode electrolyte wherein the anode electrolyte comprises saltwater and metal halide; applying a voltage to the anode and cathode and oxidizing the metal halide from a lower oxidation state to a higher oxidation state at the anode; contacting the cathode with a cathode electrolyte;

halogenating ethylene or ethane with the anode electrolyte comprising the saltwater and the metal halide in the higher oxidation state, in an aqueous medium wherein the aqueous medium comprises more than 5wt% water to form chloroethanol in more than 20wt% yield using catalysis with noble metal under one or more reaction conditions selected from temperature of halogenation mixture between about 120-160°C; incubation time of between about 10min-2hour; total halide concentration in the halogenation mixture between about 7-12M, and combinations thereof, and the metal halide in the lower oxidation state, and

using the chloroethanol to form one or more organic compounds or enantiomers thereof wherein the one or more organic compounds or enantiomers thereof are selected from the group consisting of substituted or unsubstituted dioxane, substituted or unsubstituted dioxolane, dichloroethylether, dichloromethyl methyl ether, dichloroethyl methyl ether, chloroform, carbon tetrachloride, phosgene, and combinations thereof.

[60] Accordingly, in some embodiments, there is provided a method, comprising contacting an anode with an anode electrolyte wherein the anode electrolyte comprises saltwater and metal halide; applying a voltage to the anode and cathode and oxidizing the metal halide from a lower oxidation state to a higher oxidation state at the anode; contacting the cathode with a cathode electrolyte;

halogenating ethylene or ethane with the anode electrolyte comprising the saltwater and the metal halide in the higher oxidation state, in an aqueous medium wherein the aqueous

medium comprises more than 5wt% water to form chloroethanol in more than 20wt% yield under one or more reaction conditions selected from temperature of halogenation mixture between about 120-160°C; incubation time of between about 10min-2hour; total halide concentration in the halogenation mixture between about 7-12M, and catalysis with noble metal, and the metal halide in the lower oxidation state. and

using the chloroethanol to form one or more organic compounds or enantiomers thereof, wherein the one or more organic compounds or enantiomers thereof are selected from the group consisting of substituted or unsubstituted dioxane, substituted or unsubstituted dioxolane, dichloroethylether, dichloromethyl methyl ether, dichloroethyl methyl ether, chloroform, carbon tetrachloride, phosgene, and combinations thereof.

[61] In some embodiments of the foregoing embodiments, the one or more reaction conditions are selected from temperature of halogenation mixture between about 130-160°C; incubation time of between about 10min-2hour; total halide concentration in the halogenation mixture between about 6-10M, catalysis with noble metal on support, and combinations thereof.

[62] In some embodiments of the foregoing embodiments, the yield of CE is more than 30wt% yield; or more than 40wt% yield; or more than 50wt% yield; or more than 60wt% yield; or more than 70wt% yield; or more than 80wt% yield; or more than 90wt% yield; or between 20-90wt% yield; or between 40-90wt% yield; or between 50-90wt % yield, or yield as described herein.

[63] In some embodiments of the foregoing embodiments, the noble metals are selected from ruthenium, rhodium, palladium, silver, osmium, iridium, platinum, gold, mercury, rhenium, titanium, niobium, tantalum, and combinations thereof. In some embodiments, the noble metal is selected from rhodium, palladium, silver, platinum, gold, titanium, niobium, tantalum, and combinations thereof. In some embodiments, the noble metal is palladium, platinum, titanium, niobium, tantalum, or combinations thereof. In some embodiments, the foregoing noble metal is supported on a solid. Examples of solid support include, without limitation, carbon, zeolite, titanium dioxide, alumina, silica, and the like. In some embodiments, the foregoing noble metal is supported on carbon. For example only, the catalyst is palladium over carbon. The amount of nobel metal used in the halogenation reaction is between 0.001M to 2M or other concentrations described herein.

[64] The “substituted or unsubstituted dioxane” as used herein includes heterocyclic compounds of formulas:

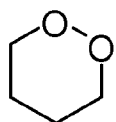
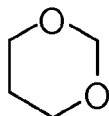
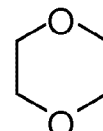
(1,2-dioxane, *o*-dioxane);(1,3-dioxane, *m*-dioxane); and

(1,4-

dioxane, *p*-dioxane)

each of which may be independently substituted with one or more of halo, alkyl, or halo substituted alkyl. The dioxane may be present in any of the above isomeric forms. The dioxane may adopt a chair conformation.

[65] The “substituted or unsubstituted dioxolane” as used herein includes heterocyclic compounds of formula:

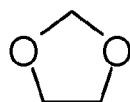

(1,3-dioxolane)

which may be independently substituted with one or more of halo, alkyl, or halo substituted alkyl.

[66] The “dichloroethylether” as used herein is a compound of formula:

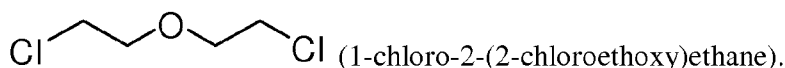

(1-chloro-2-(2-chloroethoxy)ethane).

[0001] The “dichloromethyl methyl ether” as used herein is a compound of formula:

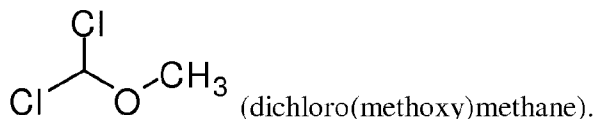

(dichloro(methoxy)methane).

[67] The “dichloroethyl methyl ether” as used herein includes 1,2- and 2,2-dichloroethyl methyl ether and is a compound of formula:

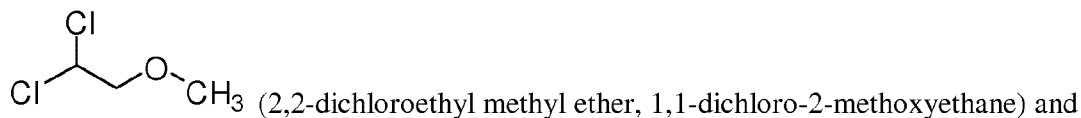

(2,2-dichloroethyl methyl ether, 1,1-dichloro-2-methoxyethane) and

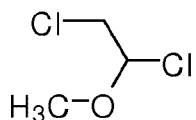

(1,2-dichloroethyl methyl ether, 1,2-dichloro-1-methoxyethane).

[68] The “chloroform” as used herein is a compound of formula CHCl_3 .

[69] The “carbon tetrachloride” as used herein is a compound of formula CCl_4 .

[70] The “phosgene” as used herein is a compound of formula COCl_2 .

[71] As used herein, “alkyl” refers to monovalent saturated aliphatic hydrocarbyl groups having from 1 to 4 carbon atoms and, in some embodiments, from 1 to 2 carbon atoms.

“ $\text{C}_x\text{-C}_y$ alkyl” refers to alkyl groups having from x to y carbon atoms. This term includes, by

way of example, linear and branched hydrocarbyl groups such as methyl (CH_3-), ethyl (CH_3CH_2-), *n*-propyl ($\text{CH}_3\text{CH}_2\text{CH}_2-$), isopropyl ($(\text{CH}_3)_2\text{CH}-$), *n*-butyl ($\text{CH}_3\text{CH}_2\text{CH}_2\text{CH}_2-$), isobutyl ($(\text{CH}_3)_2\text{CHCH}_2-$), *sec*-butyl ($(\text{CH}_3)(\text{CH}_3\text{CH}_2)\text{CH}-$), *t*-butyl ($(\text{CH}_3)_3\text{C}-$). As used herein, "halo substituted alkyl" includes alkyl substituted with one or more halo group (number of halo groups depending on permissible valency).

[72] As used herein, "halo" or "halogen" refers to fluoro, chloro, bromo, and iodo.

[73] As illustrated in **Fig. 2**, few exemplary pathways for the formation of the organic compounds are being depicted. However, without being limited by any theory, these pathways are depicted to show some exemplary pathways and other pathways to form these products are well within the scope of the invention. In some embodiments, ethylene glycol may be formed by the hydration of CE. In some embodiments, the ethylene glycol after coupling with acetaldehyde can result in the formation of dioxolane. In some embodiments, the ethylene glycol itself can couple and form dioxanes. In some embodiments, the 1,4-dioxane may be manufactured in a closed system by acid catalyzed conversion of diethylene glycol via dehydration and ring closure. Concentrated sulfuric acid (ca. 5%) may be used as the acid catalyst, although phosphoric acid, *p*-toluenesulfonic acid, strongly acidic ion-exchanged resins, and zeolites may also be used. Operating conditions vary; temperatures may range from 130 to 200°C and pressures may range from a partial vacuum to slight pressure (i.e., 188-825 mm Hg). The reaction process may be continuous and carried out in a heat vessel. The raw 1,4-dioxane product may form an azeotrope with water which may be then vaporized from the reaction vessel by distillation. The 1,4-dioxane vapors may be passed through an acid trap and two distillation columns to remove water and purify the product. The crude 1,4-dioxane may be further cleaned by heating with acids, distillation (to remove glycol and acetaldehyde), salting out with NaCl, CaCl_2 , or NaOH, and/or fine subsequent distillation.

[74] In some embodiments, the dichloroethyl ether may be formed by the coupling of CE. For example, in some embodiments, CE on treatment with concentrated sulfuric acid at 90-100°C may result in the formation of dichloroethyl ether.

[75] As illustrated in **Fig. 2**, CE can be further oxidized to various chloro-acetaldehydes. CE may be oxidized to mono-chloroacetaldehyde (MCA). MCA can then be further oxidized to di-chloro-acetaldehyde (DCA) and tri-chloroacetaldehyde (TCA). Applicants have found that certain reaction conditions can result in the formation of TCA by halogenations reaction of ethylene or ethane with metal halide in the higher oxidation state. The TCA then can be used to further form the one or more organic compounds or enantiomers thereof including,

substituted or unsubstituted dioxane, substituted or unsubstituted dioxolane, dichloroethylether, dichloromethyl methyl ether, dichloroethyl methyl ether, chloroform, carbon tetrachloride, phosgene, and combinations thereof.

[76] Applicants found that since the subsequent oxidation of CE to TCA may require multiple oxidations steps, certain reaction conditions may be controlled in order to obtain higher amounts of TCA. For example, for the production of TCA, the temperature of the reaction may be operated above 160°C (higher than the temp needed for CE formation); or between about 160-200°C; or between about 160-190°C; or between about 160-180°C; or between about 160-170°C; or between about 170-200°C; or between about 170-190°C; or between about 170-180°C; or between about 180-200°C; or between about 180-190°C; or between about 190-200°C. In some embodiments, the temperatures noted above produce TCA in more than 20wt% yield or higher yields as noted below.

[77] It was further noted that since the formation of TCA from CE required multiple oxidation steps, higher amount of the metal halide in the higher oxidation state may result in the formation of higher amounts of TCA. In some embodiments, the concentration of the metal halide in the higher oxidation state in the halogenations mixture may be more than 4.5M to produce TCA in more than 20wt% yield or higher yields as noted below. In some embodiments, the concentration of the metal halide in the higher oxidation state in the halogenations mixture is between about 4.5-8M; or between about 4.5-7M; or between about 4.5-6M; or between about 4.5-5M; or between about 5-8M; or between about 5-7M; or between about 5-6M; or between about 6-8M; or between about 6-7M; or between about 7-8M.

[78] It was also noted that the TCA formation may be increased by varying the incubation time of the halogenations mixture. In some embodiments, the incubation time for the halogenations mixture is between about 15min-10hour or more depending on the temperature of the halogenations mixture. This incubation time may be in combination with the above noted temperature ranges and/or above noted metal halide concentration. In some embodiments, the incubation time for the halogenations mixture is between about 15min-3hour; or between about 15min-2.5hour; or between about 15min-2hour; or between about 15min-1.5hour; or between about 15min-1hour; or between about 15min-30min; or between about 20min-3hour; or between about 20min-2hour; or between about 20min-1hour; or between about 30min-3hour; or between about 30min-2hour; or between about 30min-1hour;

or between about 1hour-2hour; or between about 1hour-3hour; or between about 2hour-3hour, to form TCA in more than 20wt% or higher yields as noted below.

[79] The effect of temperature, incubation time, and concentration of the metal halide in the higher oxidation state on the formation and yield of TCA can be seen in Example 3 herein.

[80] The yield of TCA by using the reaction conditions noted above includes more than 20wt% or more than 30wt% or more than 40wt% or more than 50wt% of TCA formed by the reaction of the ethylene or ethane with the metal halide in the higher oxidation state. The yield of the TCA formed using the reaction conditions described herein include, but not limited to, more than 20wt%; more than 30wt%; more than 40wt%; more than 50wt%; or more than 60wt%; or more than 70wt%; or more than 75wt%; or more than 80wt%; or more than 85wt%; or more than 90wt%; or more than 95wt%; or between about 20-99wt%; or between about 20-90wt%; or between about 20-75wt%; or between about 20-60wt%; or between about 20-50wt%; or between about 30-99wt%; or between about 30-90wt%; or between about 30-75wt%; or between about 30-60wt%; or between about 30-50wt%; or between about 40-99wt%; or between about 40-90wt%; or between about 40-75wt%; or between about 40-60wt%; or between about 40-50wt%; or between about 50-99wt%; or between about 50-95wt%; or between about 50-90wt%; or between about 50-80%; or between about 50-70wt%; or between about 50-60wt%; or between about 60-99wt%; or between about 60-90wt%; or between about 60-80wt%; or between about 60-70wt%; or between about 70-99wt%; or between about 70-90wt%; or between about 70-80wt%; or between about 80-99wt%; or between about 80-90wt%; or between about 90-99wt%. These yields of TCA may be obtained by one or more reaction conditions selected from temperature of halogenation mixture between about 160-200°C; incubation time of between about 15min-2hour; concentration of the metal halide in the higher oxidation state at more than 4.5M, and combinations thereof. The temperature ranges may be combined with the incubation time and/or with the metal halide or metal chloride concentration ranges in the higher oxidation state in order to form the above noted yields.

[81] Accordingly, in some embodiments, there is provided a method comprising contacting an anode with an anode electrolyte wherein the anode electrolyte comprises saltwater and metal halide; applying a voltage to the anode and cathode and oxidizing the metal halide from a lower oxidation state to a higher oxidation state at the anode; contacting the cathode with a cathode electrolyte;

halogenating ethylene or ethane with the anode electrolyte comprising the saltwater and the metal halide in the higher oxidation state, in an aqueous medium wherein the aqueous medium comprises more than 5wt% water to form TCA in more than 20wt% yield from the halogenation of ethylene or ethane under one or more reaction conditions selected from temperature of halogenation mixture between about 160-200°C; incubation time of between about 15min-2hour; concentration of the metal halide in the higher oxidation state at more than 4.5M, and combinations thereof, and the metal halide in the lower oxidation state, and

using the TCA to form one or more organic compounds or enantiomers thereof, wherein the one or more organic compounds or enantiomers thereof are selected from the group consisting of substituted or unsubstituted dioxane, substituted or unsubstituted dioxolane, dichloroethylether, dichloromethyl methyl ether, dichloroethyl methyl ether, chloroform, carbon tetrachloride, phosgene, and combinations thereof.

[82] In some embodiments, there is provided a method comprising contacting an anode with an anode electrolyte wherein the anode electrolyte comprises saltwater and metal halide; applying a voltage to the anode and cathode and oxidizing the metal halide from a lower oxidation state to a higher oxidation state at the anode; contacting the cathode with a cathode electrolyte;

halogenating ethylene or ethane with the anode electrolyte comprising the saltwater and the metal halide in the higher oxidation state, in an aqueous medium wherein the aqueous medium comprises more than 5wt% water to form TCA in more than 20wt% yield and the metal halide in the lower oxidation state from the halogenation of ethylene or ethane under one or more reaction conditions selected from temperature of halogenation mixture between about 160-200°C; incubation time of between about 15min-2hour; and/or concentration of the metal halide in the higher oxidation state at more than 4.5M, and

using the TCA to form one or more organic compounds or enantiomers thereof, wherein the one or more organic compounds or enantiomers thereof are selected from the group consisting of substituted or unsubstituted dioxane, substituted or unsubstituted dioxolane, dichloroethylether, dichloromethyl methyl ether, dichloroethyl methyl ether, chloroform, carbon tetrachloride, phosgene, and combinations thereof.

[83] In some embodiments of the foregoing embodiments, the saltwater comprises water comprising alkali metal ions. In some embodiments of the foregoing embodiments, the saltwater comprises water comprising alkaline earth metal ions.

[84] In some embodiments of the foregoing embodiments, the one or more reaction conditions are selected from temperature of halogenation mixture between about 180-200°C;

incubation time of between about 15min-2hour; and concentration of the metal halide in the higher oxidation state at more than 5M or between 4.5-8M, and combinations thereof.

[85] In some embodiments of the foregoing embodiments, the yield of TCA is more than 30wt% yield; or more than 40wt% yield; or more than 50wt% yield; or more than 60wt% yield; or more than 70wt% yield; or more than 80wt% yield; or more than 90wt% yield; or between 20-90wt% yield; or between 40-90wt% yield; or between 50-90wt % yield, or yield as described herein.

[86] In some embodiments, there is provided a method comprising contacting an anode with an anode electrolyte wherein the anode electrolyte comprises saltwater and metal halide; applying a voltage to the anode and cathode and oxidizing the metal halide from a lower oxidation state to a higher oxidation state at the anode; contacting the cathode with a cathode electrolyte;

halogenating ethylene or ethane with the anode electrolyte comprising the saltwater and the metal halide in the higher oxidation state, in an aqueous medium wherein the aqueous medium comprises more than 5wt% water to form

chloroethanol in more than 20wt% yield under one or more reaction conditions selected from temperature of halogenation mixture between about 120-160°C; incubation time of between about 10min-2hour; total halide concentration in the halogenation mixture between about 7-12M, catalysis with noble metal, and combinations thereof, and/or

TCA in more than 20wt% yield under one or more reaction conditions selected from temperature of halogenation mixture between about 160-200°C; incubation time of between about 15min-2hour; concentration of the metal halide in the higher oxidation state at more than 4.5M, and combinations thereof, and the metal halide in the lower oxidation state, and

using the CE or TCA to form one or more organic compounds or enantiomers thereof, wherein the one or more organic compounds or enantiomers thereof are selected from the group consisting of substituted or unsubstituted dioxane, substituted or unsubstituted dioxolane, dichloroethylether, dichloromethyl methyl ether, dichloroethyl methyl ether, chloroform, carbon tetrachloride, phosgene, and combinations thereof.

[87] In some embodiments, there is provided a method comprising contacting an anode with an anode electrolyte wherein the anode electrolyte comprises saltwater and metal halide; applying a voltage to the anode and cathode and oxidizing the metal halide from a lower oxidation state to a higher oxidation state at the anode; contacting the cathode with a cathode electrolyte;

halogenating ethylene or ethane with the anode electrolyte comprising the saltwater and the metal halide in the higher oxidation state, in an aqueous medium wherein the aqueous medium comprises more than 5wt% water to form

chloroethanol in more than 20wt% yield by catalyzing with noble metal and under one or more reaction conditions selected from temperature of halogenation mixture between about 120-160°C; incubation time of between about 10min-2hour; total halide concentration in the halogenation mixture between about 7-12M, and combinations thereof, and/or

TCA in more than 20wt% yield under one or more reaction conditions selected from temperature of halogenation mixture between about 160-200°C; incubation time of between about 15min-2hour; concentration of the metal halide in the higher oxidation state at more than 4.5M, and combinations thereof, and the metal halide in the lower oxidation state, and

using the CE or TCA to form one or more organic compounds or enantiomers thereof, wherein the one or more organic compounds or enantiomers thereof are selected from the group consisting of substituted or unsubstituted dioxane, substituted or unsubstituted dioxolane, dichloroethylether, dichloromethyl methyl ether, dichloroethyl methyl ether, chloroform, carbon tetrachloride, phosgene, and combinations thereof.

[88] As illustrated in **Fig. 2**, some exemplary pathways for the formation of dioxolanes from chloroacetaldehydes are being depicted.

[89] In some embodiments, TCA may be used to form products such as, chloroform, carbon tetrachloride, and/or phosgene (not illustrated in Fig. 2). In some embodiments, TCA may be reacted with a base to form chloroform. For example, in some embodiments, TCA may be treated with sodium hydroxide solutions in concentrations in the range of 5 to 20% by weight or 8 to 15% by weight. In some embodiments, the chloroform can be used to form phosgene by photooxidation. For example in some embodiments, the intrazeolite photooxidation of chloroform may result in the formation of phosgene.

[90] It is to be understood that one or more of the embodiments provided herein can be combined in the methods and system provided herein.

[91] In some embodiments, the solution containing the one or more organic compounds and the metal halide may be subjected to washing step which may include rinsing with an organic solvent or passing the organic product through a column to remove the metal ions. In some embodiments, the organic products may be purified by distillation.

[92] In some embodiments, the STY (space time yield) of the one or more organic compounds or enantiomers thereof from ethylene or ethane, e.g. the STY of CE from ethylene or STY of TCA from ethylene or ethane using the metal ions is more than 0.1, or

more than 0.5, or is 1, or more than 1, or more than 2, or more than 3, or more than 4, or more than 5, or between 0.1-3, or between 0.5-3, or between 0.5-2, or between 0.5-1, or between 3-5, or between 3-6, or between 3-8. As used herein the STY is yield per time unit per reactor volume. For example, the yield of product may be expressed in mol, the time unit in hour and the volume in liter. The volume may be the nominal volume of the reactor, e.g. in a packed bed reactor, the volume of the vessel that holds the packed bed is the volume of the reactor. The STY may also be expressed as STY based on the consumption of the ethylene or ethane consumed to form the product. For example only, in some embodiments, the STY of the CE product may be deduced from the amount of ethylene consumed during the reaction. The selectivity may be the mol of product/mol of the ethylene or ethane consumed (e.g. only, mol CE or TCA made/mol ethylene consumed). The yield may be the amount of the product isolated. The purity may be the amount of the product/total amount of all products (e.g. only, amount of CE or TCA/all the organic products formed).

[93] In one aspect, there are provided systems comprising an anode chamber comprising an anode in contact with a metal halide and saltwater in an anode electrolyte, wherein the anode is configured to oxidize the metal halide from a lower oxidation state to a higher oxidation state; and a cathode chamber comprising a cathode in contact with a cathode electrolyte wherein the cathode is configured to form an alkali, water, and/or hydrogen gas in the cathode electrolyte; and a reactor operably connected to the anode chamber and configured to contact the anode electrolyte comprising saltwater and metal halide in the higher oxidation state with ethylene or ethane to form one or more organic compounds or enantiomers thereof and the metal halide in the lower oxidation state in an aqueous medium wherein the aqueous medium comprises more than 5wt% water; wherein the one or more organic compounds or enantiomers thereof are selected from the group consisting of substituted or unsubstituted dioxane, substituted or unsubstituted dioxolane, dichloroethylether, dichloromethyl methyl ether, dichloroethyl methyl ether, chloroform, carbon tetrachloride, phosgene, and combinations thereof.

[94] In some embodiments, there is provided a system comprising:

an electrochemical system comprising an anode chamber comprising an anode in contact with an anode electrolyte, wherein the anode electrolyte comprises saltwater and metal halide, wherein the anode is configured to oxidize the metal halide from a lower oxidation state to a higher oxidation state; and a cathode chamber comprising a cathode in contact with a cathode electrolyte;

a first reactor operably connected to the anode chamber and configured to react ethylene or ethane with the anode electrolyte comprising the saltwater and the metal halide in the higher oxidation state to form more than 20 wt% CE wherein the reactor is configured to provide one or more reaction conditions selected from temperature of reaction mixture between about 120-160°C; incubation time of between about 10min-2hour; total halide concentration in the reaction mixture between about 6-12M, catalysis with noble metal, and combinations thereof; and/or to form more than 20 wt% TCA wherein the reactor is configured to provide one or more reaction conditions selected from temperature of halogenation mixture between about 160-200°C; incubation time of between about 15min-2hour; concentration of the metal halide in the higher oxidation state at more than 4.5M, and combinations thereof, and

a second reactor operably connected to the first reactor and configured to form the one or more organic compounds or enantiomers thereof selected from the group consisting of substituted or unsubstituted dioxane, substituted or unsubstituted dioxolane, dichloroethylether, dichloromethyl methyl ether, dichloroethyl methyl ether, chloroform, carbon tetrachloride, phosgene, and combinations thereof, from the CE or TCA.

[95] In some embodiments of the foregoing embodiments, the one or more reaction conditions to form CE are selected from temperature of halogenation mixture between about 130-160°C; incubation time of between about 10min-2hour; total halide concentration in the halogenation mixture between about 6-10M, catalysis with noble metal on support, and combinations thereof.

[96] In some embodiments of the foregoing embodiments, the yield of CE is more than 30wt% yield; or more than 40wt% yield; or more than 50wt% yield; or more than 60wt% yield; or more than 70wt% yield; or more than 80wt% yield; or more than 90wt% yield; or between 20-90wt% yield; or between 40-90wt% yield; or between 50-90wt % yield, or yield as described herein.

[97] In some embodiments of the foregoing embodiments, the one or more reaction conditions to form TCA are selected from temperature of halogenation mixture between about 180-200°C; incubation time of between about 15min-2hour; and concentration of the metal halide in the higher oxidation state at more than 5M or between 4.5-8M, and combinations thereof.

[98] In some embodiments of the foregoing embodiments, the yield of TCA is more than 30wt% yield; or more than 40wt% yield; or more than 50wt% yield; or more than 60wt% yield; or more than 70wt% yield; or more than 80wt% yield; or more than 90wt% yield; or

between 20-90wt% yield; or between 40-90wt% yield; or between 50-90wt % yield, or yield as described herein.

[99] In some embodiments, the system further comprises a separator to separate and/or purify the one or more organic compounds or enantiomers thereof from the metal halide solution. In some embodiments, the system further comprises a recirculation system to recirculate the separated metal halide solution comprising metal halide in the lower oxidation state and optionally comprising metal halide in the higher oxidation state, back to the anode electrolyte.

[100] The systems provided herein include the reactor operably connected to the anode chamber that carries out the halogenations or any other organic reaction. The “reactor” as used herein is any vessel or unit in which the reaction provided herein is carried out. The reactor is configured to contact the metal halide in the anode electrolyte with the ethylene or ethane to form the one or more organic compounds or enantiomers thereof. The reactor may be any means for contacting the metal halide in the anode electrolyte with the ethylene or ethane. Such means or such reactor are well known in the art and include, but not limited to, pipe, column, duct, tank, series of tanks, container, tower, conduit, and the like. The reactor may be equipped with one or more of controllers to control temperature sensor, pressure sensor, control mechanisms, inert gas injector, etc. to monitor, control, and/or facilitate the reaction.

[101] In some embodiments, the reactor system may be a series of reactors connected to each other. For example, to increase the yield of chloroethanol by increasing the incubation time, the halogenation mixture may be kept either in the same reaction vessel (or reactor), or in a second reaction vessel that does not contain ethylene. Since EDC solubility may be limited in the anolyte, a second reaction vessel may need to be a stirred tank. The stirring may increase the mass transfer rate of EDC into the aqueous anolyte phase accelerating the reaction to CE or TCA. In some embodiments, the formation of EDC, CE/TCA, and the one or more organic compounds or enantiomers thereof, all take place in separate reactors where the reactors are operably connected to each other for the flow of liquids and gases in and out of the reactors.

[102] In some embodiments, the anode chamber of the electrochemical system (electrochemical system can be any electrochemical system described herein) is connected to a reactor which is also connected to a source of ethylene or ethane. In some embodiments, the electrochemical system and the reactor may be inside the same unit and are connected inside the unit. The anode electrolyte, containing the metal ion in the higher oxidation state

optionally with the metal ion in the lower oxidation state, along with ethylene are fed to a prestressed (e.g., brick-lined) reactor. The chlorination of ethylene takes place inside the reactor to form ethylene dichloride (EDC or dichloroethane DCE) and the metal ion in the lower oxidation state which EDC is subjected to the reaction conditions described herein to form CE or TCA.

[103] The reactor effluent gases may be quenched with water in the prestressed (e.g., brick-lined) packed tower. The liquid leaving the tower maybe cooled further and separated into the aqueous phase and organic phase. The aqueous phase may be split part being recycled to the tower as quench water and the remainder may be recycled to the reactor or the electrochemical system. The organic product may be cooled further and flashed to separate out more water and dissolved ethylene. This dissolved ethylene may be recycled back to the reactor. The uncondensed gases from the quench tower may be recycled to the reactor, except for the purge stream to remove inerts. The purge stream may go through the ethylene recovery system to keep the over-all utilization of ethylene high, e.g., as high as 95%. Experimental determinations may be made of flammability limits for ethylene gas at actual process temperature, pressure and compositions. The construction material of the plant may include prestressed brick linings, Hastelloys B and C, inconel, dopant grade titanium (e.g. AKOT, Grade II), tantalum, Kynar, Teflon, PEEK, glass, or other polymers or plastics. The reactor may also be designed to continuously flow the anode electrolyte in and out of the reactor.

[104] The reaction conditions described herein may be selected in such a way that the one or more organic compounds or enantiomers thereof are produced with high selectivity, high yield, and/or high STY.

[105] In some embodiments, the reaction between the metal chloride with metal ion in higher oxidation state and the ethylene or ethane, is carried out in the reactor provided herein under reaction conditions including, but not limited to, the temperature of between 120-200°C or between 120-175°C or between 150-185°C or between 150-175°C; pressure of between 100-500psig or between 100-400psig or between 100-300psig or between 150-350psig or between 200-300psig, or combinations thereof depending on the desired CE or TCA product. The reactor provided herein is configured to operate at the temperature of between 120-200°C or between 120-185°C or between 150-200°C or between 150-175°C; pressure of between 100-500psig or between 100-400psig or between 100-300psig or between 150-350psig or between 200-300psig, or combinations thereof depending on the desired CE or TCA product. In some embodiments, the components of the reactor are lined with Teflon to prevent

corrosion of the components. In some embodiments, the reactor provided herein may operate under reaction conditions including, but not limited to, the temperature and pressure in the range of between 135-180°C, or between 135-175°C, or between 140-180°C, or between 140-170°C, or between 140-160°C, or between 150-180°C, or between 150-170°C, or between 150-160°C, or between 155-165°C, or 140°C, or 150°C, or 160°C, or 170°C and 200-300 psig depending on the desired CE or TCA product. In some embodiments, the reactor provided herein may operate under reaction conditions including, but not limited to, the temperature and pressure in the range of between 135-180°C, or between 135-175°C, or between 140-180°C, or between 140-170°C, or between 140-160°C, or between 150-180°C and 200-300 psig depending on the desired CE or TCA product.

[106] One or more of the reaction conditions include, such as, but not limited to, temperature of the halogenation mixture, incubation time, total halide concentration in the halogenation mixture, concentration of the metal halide in the higher oxidation state, and/or the presence of noble metal catalyst can be set to assure high selectivity, high yield, and/or high STY operation. Various reaction conditions have been illustrated in the examples section.

[107] Reaction heat may be removed by vaporizing water or by using heat exchange units. In some embodiments, a cooling surface may not be required in the reactor and thus no temperature gradients or close temperature control may be needed.

[108] In some embodiments, the methods and systems provided herein produce the CE/TCA with more than about 0.1 STY or more than about 0.5 STY or between 0.1-5 STY, or between 0.5-3 STY, or more than about 80% selectivity or between 80-99% selectivity. In some embodiments of the aforementioned embodiments, the reaction conditions produce the CE/TCA with selectivity of more than 80%; or between about 80-99%; or between about 80-99.9%; or between about 90-99.9%; or between about 95-99.9%.

[109] In some embodiments, the design and configuration of the reactor may be selected in such a way that the CE or TCA is produced with high selectivity, high yield, high purity, and/or high STY. The reactor configuration includes, but not limited to, design of the reactor such as, e.g. length/diameter ratio, flow rates of the liquid and gases, material of construction, packing material and type if reactor is packed column or trickle-bed reactor, or combinations thereof. In some embodiments, the systems may include one reactor or a series of multiple reactors connected to each other or operating separately. The reactor may be a packed bed such as, but not limited to, a hollow tube, pipe, column or other vessel filled with packing material. The reactor may be a trickle-bed reactor. In some embodiments, the packed bed

reactor includes a reactor configured such that the aqueous medium containing the metal ions and the ethylene or ethane (e.g. ethylene gas) flow counter-currently in the reactor or includes the reactor where the aqueous medium containing the metal ions flows in from the top of the reactor and the ethylene gas is pressured in from the bottom at e.g., but not limited to, 250 psi. In some embodiments, in the latter case, the ethylene gas may be pressured in such a way that only when the ethylene gas gets consumed and the pressure drops, that more ethylene gas flows into the reactor. The trickle-bed reactor includes a reactor where the aqueous medium containing the metal ions and the ethylene or ethane (e.g. ethylene gas) flow co-currently in the reactor.

[110] In some embodiments, the ethylene or ethane feedstock may be fed to the halogenation vessel or the reactor continuously or intermittently. Efficient halogenation may be dependent upon achieving intimate contact between the feedstock and the metal ion in solution and the halogenation reaction may be carried out by a technique designed to improve or maximize such contact. The metal ion solution may be agitated by stirring or shaking or any desired technique, e.g. the reaction may be carried out in a column, such as a packed column, or a trickle-bed reactor or reactors described herein. For example, where the ethylene or ethane is gaseous, a counter-current technique may be employed wherein the ethylene or ethane is passed upwardly through a column or reactor and the metal ion solution is passed downwardly through the column or reactor. In addition to enhancing contact of the ethylene or ethane and the metal ion in the solution, the techniques described herein may also enhance the rate of dissolution of the ethylene or ethane in the solution, as may be desirable in the case where the solution is aqueous and the water-solubility of the ethylene or ethane is low. Dissolution of the feedstock may also be assisted by higher pressures.

[111] In some embodiments, the reactor (may be a trickle bed or packed bed reactor) is configured in such a way that the length (or the height)/diameter ratio of the reactor is between 2-40 (e.g. 2:1 to 40:1); or between 2-35; or between 2-30; or between 2-20; or between 2-15; or between 2-10; or between 2-5; or between 3-40; or between 3-35; or between 3-30; or between 3-20; or between 3-10; or between 3-5; or between 4-40; or between 4-35; or between 4-30; or between 4-20; or between 4-10; or between 4-5; or between 6-40; or between 6-35; or between 6-30; or between 6-20; or between 6-10; or between 10-40; or between 10-35; or between 10-30; or between 10-25; or between 10-20; or between 10-15; or between 15-40; or between 15-35; or between 15-30; or between 15-25; or between 20-40; or between 20-35; or between 20-30; or between 20-25; or between 25-40; or between 25-35; or between 25-30; or between 30-40. In some embodiments, the foregoing

diameter is the outside diameter of the reactor. In some embodiments, the foregoing diameter is the inside diameter of the reactor. For example, in some embodiments, the length/diameter ratio of the reactor is between about 2-15; or 2-20; or 2-25; or 10-15; or 10-25; or 20-25; or 20-30; or 30-40; or 35-40; or 4-25; or 6-15; or between 2:1-40:1; or between 2:1-10:1 or about 3:1 or about 4:1.

[112] A variety of packing material of various shapes, sizes, structure, wetting characteristics, form, and the like may be used in the packed bed or trickle bed reactor, described herein. The packing material includes, but not limited to, polymer (e.g. only Teflon PTFE), ceramic, glass, metal, natural (wood or bark), or combinations thereof. In some embodiments, the packing can be structured packing or loose or unstructured or random packing or combination thereof. The “structured packing” as used herein includes unflowable corrugated metal plates or gauzes. In some embodiments, the structured packing material individually or in stacks fits fully in the diameter of the reactor. The “unstructured packing” or “loose packing” or “random packing” as used herein includes flowable void filling packing material.

[113] Examples of loose or unstructured or random packing material include, but not limited to, Raschig rings (such as in ceramic material), pall rings (e.g. in metal and plastic), lessing rings, Michael Bialecki rings (e.g. in metal), berl saddles, intalox saddles (e.g. in ceramic), super intalox saddles, tellerette® ring (e.g. spiral shape in polymeric material), etc.

[114] In some embodiments, the size of the unstructured packing material may vary and may be between about 2mm to about 5 inches or between about ¼ of an inch to about 5 inches. In some embodiments, the size of the packing material is between about 2mm to about 5 inches; or about 2mm to about 4 inches; or about 2mm to about 3 inches; or about 2mm to about 2 inches; or about 2mm to about 1 inch; or about 2mm to about ½ inch; or about 2mm to about ¼ inch; or about ¼ of an inch to about 5 inches; or about ¼ of an inch to about 4 inches; or about ¼ of an inch to about 3 inches; or about ¼ of an inch to about 2 inches; or about ¼ of an inch to about 1 inch; or about ¼ of an inch to about ½ inch; or about 1/3 of an inch to about 5 inches; or about 1/3 of an inch to about 2 inches; or about ½ of an inch to about 5 inches; or about ½ of an inch to about 4 inches; or about ½ of an inch to about 3 inches; or about ½ of an inch to about 2 inches; or about ½ of an inch to about 1 inch; or about 1 inch to about 5 inches; or about 1 inch to about 4 inches; or about 1 inch to about 3 inches; or about 1 inch to about 2 inches; or about 1 inch to about ½ inches; or about 1 inch to about ¼ inches; or about 2 inch to about 5 inches; or about 3 inch to about 5 inches; or about 4 inch to about 5 inches. In some embodiments, the size of the packing material is between

about ¼ of an inch to about 4 inches; or about ½ of an inch to about 3 inches; or about 1 inch to about 2 inches.

[115] Examples of structured packing material include, but not limited to, thin corrugated metal plates or gauzes (honeycomb structures) in different shapes with a specific surface area. The structured packing material may be used as a ring or a layer or a stack of rings or layers that have diameter that may fit into the diameter of the reactor. The ring may be an individual ring or a stack of rings fully filling the reactor. In some embodiments, the voids left out by the structured packing in the reactor are filled with the unstructured packing material.

[116] Examples of structured packing material includes, without limitation, Flexipac[®], Intalox[®], Flexipac[®] HC[®], etc. In a structured packing material, corrugated sheets may be arranged in a crisscross pattern to create flow channels for the vapor phase. The intersections of the corrugated sheets may create mixing points for the liquid and vapor phases. The structured packing material may be rotated about the column (reactor) axis to provide cross mixing and spreading of the vapor and liquid streams in all directions. The structured packing material may be used in various corrugation sizes and the packing configuration may be optimized to attain the highest efficiency, capacity, and pressure drop requirements of the reactor. The structured packing material may be made of a material of construction including, but not limited to, titanium, stainless steel alloys, carbon steel, aluminum, nickel alloys, copper alloys, zirconium, thermoplastic, etc. The corrugation crimp in the structured packing material may be of any size, including, but not limited to, Y designated packing having an inclination angle of 45° from the horizontal or X designated packing having an inclination angle of 60° from the horizontal. The X packing may provide a lower pressure drop per theoretical stage for the same surface area. The specific surface area of the structured packing may be between 50-800 m²/m³; or between 75-350 m²/m³; or between 200-800 m²/m³; or between 150-800 m²/m³; or between 500-800 m²/m³.

[117] In some embodiments, the structured or the unstructured packing material as described above is used in the distillation or flash column described herein for separation and purification of the products.

[118] In some embodiments, the reactor may be configured for both the reaction and separation of the products. The processes and systems described herein may be batch processes or systems or continuous flow processes or systems.

[119] All the electrochemical and reactor systems and methods described herein are carried out in more than 5wt% water or more than 6wt% water or aqueous medium. In one aspect,

the methods and systems provide an advantage of conducting the metal oxidation reaction in the electrochemical cell and reduction reaction outside the cell, all in an aqueous medium. The use of aqueous medium, in the halogenations of the ethylene or ethane, not only resulted in high yield and high selectivity of the product (shown in examples herein) but also resulted in the generation of the reduced metal ion with lower oxidation state in the aqueous medium which could be re-circulated back to the electrochemical system. In some embodiments, since the electrochemical cell runs efficiently in the aqueous medium, no removal or minimal removal of water (such as through azeotropic distillation) is required from the anode electrolyte containing the metal ion in the higher oxidation state which is reacted with the ethylene or ethane in the aqueous medium. Therefore, the use of the aqueous medium in both the electrochemical cell and the catalysis system provides efficient and less energy intensive integrated systems and methods of the invention.

[120] The reaction of the ethylene or ethane with the metal ion in the higher oxidation state, as described in the aspects and embodiments herein, is carried out in the aqueous medium. In some embodiments, such reaction may be in a non-aqueous liquid medium which may be a solvent for the ethylene or ethane feedstock. The liquid medium or solvent may be aqueous or non-aqueous. Suitable non-aqueous solvents being polar and non-polar aprotic solvents, for example dimethylformamide (DMF), dimethylsulphoxide (DMSO), halogenated hydrocarbons, for example only, dichloromethane, carbon tetrachloride, and 1,2-dichloroethane, and organic nitriles, for example, acetonitrile. Organic solvents may contain a nitrogen atom capable of forming a chemical bond with the metal in the lower oxidation state thereby imparting enhanced stability to the metal ion in the lower oxidation state. In some embodiments, acetonitrile is the organic solvent.

[121] In some embodiments, when the organic solvent is used for the reaction between the metal ion in the higher oxidation state with the ethylene or ethane, the water may need to be removed from the metal containing medium. As such, the metal ion obtained from the electrochemical systems described herein may contain water. In some embodiments, the water may be removed from the metal ion containing medium by azeotropic distillation of the mixture. In some embodiments, the solvent containing the metal ion in the higher oxidation state and the ethylene or ethane may contain between 5-90%; or 5-80%; or 5-70%; or 5-60%; or 5-50%; or 5-40%; or 5-30%; or 5-20%; or 5-10% by weight of water in the reaction medium. The amount of water which may be tolerated in the reaction medium may depend upon the particular halide carrier in the medium, the tolerable amount of water being greater,

for example, for copper chloride than for ferric chloride. Such azeotropic distillation may be avoided when the aqueous medium is used in the reactions.

[122] In some embodiments, the reaction of the metal ion in the higher oxidation state with the ethylene or ethane may take place when the reaction temperature is above 120°C up to 350°C. In aqueous media, the reaction may be carried out under a super atmospheric pressure of up to 1000 psi or less to maintain the reaction medium in liquid phase at a temperature of from 120°C to 200°C, typically from about 120°C to about 180°C.

[123] In some embodiments, a non-halide salt of the metal may be added to the solution containing metal ion in the higher oxidation state. The added metal salt may be soluble in the metal halide solution. Examples of suitable salts for incorporating in cupric chloride solutions include, but are not limited to, copper sulphate, copper nitrate and copper tetrafluoroborate. In some embodiments a metal halide may be added that is different from the metal halide employed in the methods and systems. For example, ferric chloride may be added to the cupric chloride systems at the time of halogenations of the ethylene or ethane.

[124] Mixtures of ethylene or ethane may be employed. In some embodiments, partially-halogenated products of the process of the invention which are capable of further halogenation may be recirculated to the reaction vessel through a product-recovery stage and, if appropriate, a metal ion in the lower oxidation state regeneration stage. In some embodiments, the halogenation reaction may continue outside the halogenation reaction vessel, for example in a separate regeneration vessel, and care may need to be exercised in controlling the reaction to form CE or TCA.

Electrochemical compositions, methods, and systems

Electrochemical cell

[125] The systems and methods of the invention use an electrochemical cell that produces various products, such as, but not limited to, metal salts formed at the anode, the metal salts used to form various other chemicals, alkali formed at the cathode, alkali used to form various other products, and/or hydrogen gas formed at the cathode. All of such products have been defined herein and may be called green chemicals since such chemicals are formed using the electrochemical cell that runs at low voltage or energy and high efficiency. The low voltage or less energy intensive process described herein would lead to lesser emission of carbon dioxide as compared to conventional methods of making similar chemicals or products.

[126] The electrochemical cell provided herein may be any electrochemical cell where the metal ion in the lower oxidation state is converted to the metal ion in the higher oxidation

state in the anode chamber. In such electrochemical cells, cathode reaction may be any reaction that does or does not form an alkali in the cathode chamber. Such cathode consumes electrons and carries out any reaction including, but not limited to, the reaction of water to form hydroxide ions and hydrogen gas or reaction of oxygen gas and water to form hydroxide ions or reduction of protons from an acid such as hydrochloric acid to form hydrogen gas or reaction of protons from hydrochloric acid and oxygen gas to form water.

[127] In some embodiments, the electrochemical cells may include production of alkali in the cathode chamber of the cell. The alkali generated in the cathode chamber may be used as is for commercial purposes or may be treated with divalent cations to form divalent cation containing carbonates/bicarbonates. In some embodiments, the alkali generated in the cathode chamber may be used to sequester or capture carbon dioxide. The carbon dioxide may be present in flue gas emitted by various industrial plants. The carbon dioxide may be sequestered in the form of carbonate and/or bicarbonate products. Therefore, both the anode electrolyte as well as the cathode electrolyte can be used for generating products that may be used for commercial purposes thereby providing a more economical, efficient, and less energy intensive process.

[128] The electrochemical systems and methods described herein provide one or more advantages over conventional electrochemical systems known in the art, including, but not limited to, no requirement of gas diffusion anode; higher cell efficiency; lower voltages; platinum free anode; sequestration of carbon dioxide; green and environment friendly chemicals; and/or formation of various commercially viable products.

[129] In some method and system embodiments, the anode does not produce chlorine gas. In some method and system embodiments, the treatment of the ethylene or ethane with the metal halide in the higher oxidation state does not require oxygen gas and/or chlorine gas. In some method and system embodiments, the anode does not produce chlorine gas and the treatment of the ethylene or ethane with the metal halide in the higher oxidation state does not require oxygen gas and/or chlorine gas.

[130] Some embodiments of the electrochemical cells used in the methods and systems provided herein are as illustrated in the figures and as described herein. It is to be understood that the figures are for illustration purposes only and that variations in the reagents and set up are well within the scope of the invention. All the electrochemical methods and systems described herein do not produce a gas at the anode such as chlorine gas, as is found in the chlor-alkali systems. In some embodiments, the systems and methods provided herein, do not use oxygen gas in the catalytic reactor.

[131] As illustrated in **Fig. 3**, the electrochemical system includes an anode chamber with an anode in contact with an anode electrolyte where the anode electrolyte contains metal ions in the lower oxidation state (represented as M^{L+}) which are converted by the anode to metal ions in the higher oxidation state (represented as M^{H+}). The metal ion may be in the form of a halide, such as, but not limited to, fluoride, chloride, bromide, or iodide.

[132] As used herein “lower oxidation state” represented as L+ in M^{L+} includes the lower oxidation state of the metal. For example, lower oxidation state of the metal ion may be 1+, 2+, 3+, 4+, or 5+. As used herein “higher oxidation state” represented as H+ in M^{H+} includes the higher oxidation state of the metal. For example, higher oxidation state of the metal ion may be 2+, 3+, 4+, 5+, or 6+.

[133] The electron(s) generated at the anode are used to drive the reaction at the cathode. The cathode reaction may be any reaction known in the art. The anode chamber and the cathode chamber may be separated by an ion exchange membrane (IEM) that may allow the passage of ions, such as, but not limited to, sodium ions in some embodiments to the cathode electrolyte if the anode electrolyte also comprises saltwater such as, alkali metal ions (in addition to the metal ions such as metal halide), such as, sodium chloride, sodium bromide, sodium iodide, sodium sulfate, or ammonium ions if the anode electrolyte is ammonium chloride or alkaline earth metal ions if the anode electrolyte comprises alkaline earth metal ions such as, calcium, magnesium, strontium, barium, etc. or an equivalent solution containing metal halide. Some reactions that may occur at the cathode include, but not limited to, when cathode electrolyte comprises water then reaction of water to form hydroxide ions and hydrogen gas; when cathode electrolyte comprises water then reaction of oxygen gas and water to form hydroxide ions; when cathode electrolyte comprises HCl then reduction of HCl to form hydrogen gas; or when cathode electrolyte comprises HCl then reaction of HCl and oxygen gas to form water.

[134] In some embodiments, the electrochemical system includes a cathode chamber with a cathode in contact with the cathode electrolyte that forms hydroxide ions in the cathode electrolyte. In some embodiments, the ion exchange membrane allows the passage of anions, such as, but not limited to, fluoride ions, chloride ions, bromide ions, or iodide ions to the anode electrolyte if the cathode electrolyte is e.g., sodium chloride, sodium bromide, sodium iodide, or sodium sulfate or an equivalent solution. The sodium ions combine with hydroxide ions in the cathode electrolyte to form sodium hydroxide. The anions combine with metal ions to form metal halide. It is to be understood that other cathodes such as, cathode reducing

HCl to form hydrogen gas or cathode reacting both HCl and oxygen gas to form water, are equally applicable to the systems. Such cathodes have been described herein.

[135] In some embodiments, the electrochemical systems of the invention include one or more ion exchange membranes. In some embodiments, the ion exchange membrane is a cation exchange membrane (CEM), an anion exchange membrane (AEM); or combination thereof.

[136] As illustrated in **Fig. 4** (or also illustrated in Fig. 3), the electrochemical system includes a cathode in contact with a cathode electrolyte and an anode in contact with an anode electrolyte. The cathode forms hydroxide ions in the cathode electrolyte and the anode converts metal ions from lower oxidation state (M^{L+}) to higher oxidation state (M^{H+}). The anode and the cathode are separated by an anion exchange membrane (AEM) and a cation exchange membrane (CEM). A third electrolyte (e.g., sodium fluoride, sodium chloride, sodium bromide, sodium iodide, ammonium chloride, or combinations thereof or an equivalent solution) is disposed between the AEM and the CEM. The sodium ions from the third electrolyte pass through CEM to form sodium hydroxide in the cathode chamber and the halide anions such as, chloride, bromide or iodide ions, from the third electrolyte pass through the AEM to form a solution for metal halide in the anode chamber. The metal halide formed in the anode electrolyte of saltwater is then delivered to a reactor for reaction with ethylene or ethane to generate one or more organic compounds or enantiomers thereof. The third electrolyte, after the transfer of the ions, can be withdrawn from the middle chamber as depleted ion solution. For example, in some embodiments when the third electrolyte is sodium chloride solution, then after the transfer of the sodium ions to the cathode electrolyte and transfer of chloride ions to the anode electrolyte, the depleted sodium chloride solution may be withdrawn from the middle chamber. The depleted salt solution may be used for commercial purposes or may be transferred to the anode and/or cathode chamber as an electrolyte or concentrated for re-use as the third electrolyte. In some embodiments, the depleted salt solution may be useful for preparing desalinated water. It is to be understood that the hydroxide forming cathode, as illustrated in **Fig. 4** is for illustration purposes only and other cathodes such as, cathode reducing HCl to form hydrogen gas or cathode reacting both HCl and oxygen gas to form water, are equally applicable to the systems and have been described further herein.

[137] In some embodiments, the ion exchange membrane described herein, is an anion exchange membrane, as illustrated in **Fig. 5A**. In such embodiments, the cathode electrolyte (or the third electrolyte in the third chamber) may be a sodium halide, ammonium halide, or

an equivalent solution and the AEM is such that it allows the passage of anions to the anode electrolyte but prevents the passage of metal ions from the anode electrolyte to the cathode electrolyte (or to the third electrolyte in the third chamber). In some embodiments, the ion exchange membrane described herein, is a cation exchange membrane, as illustrated in **Fig. 5B**. In such embodiments, the anode electrolyte (or the third electrolyte in the third chamber) may be a sodium halide (or other alkali or alkaline earth metal halide), ammonium halide, or an equivalent solution containing the metal halide solution or an equivalent solution and the CEM is such that it allows the passage of alkali metal ions such as, sodium cations or alkaline earth metal ions, such as calcium ions to the cathode electrolyte but prevents the passage of metal ions from the anode electrolyte to the cathode electrolyte. In some embodiments, both the AEM and CEM may be joined together in the electrochemical system. In some embodiments, the use of one ion exchange membrane instead of two ion exchange membranes may reduce the resistance offered by multiple IEMs and may facilitate lower voltages for running the electrochemical reaction. Some examples of the suitable anion exchange membranes are provided further herein.

[138] The electrochemical cells in the methods and systems provided herein are membrane electrolyzers. The electrochemical cell may be a single cell or may be a stack of cells connected in series or in parallel. The electrochemical cell may be a stack of 5 or 6 or 50 or 100 or more electrolyzers connected in series or in parallel. Each cell comprises an anode, a cathode, and an ion exchange membrane.

[139] In some embodiments, the electrolyzers provided herein are monopolar electrolyzers. In the monopolar electrolyzers, the electrodes may be connected in parallel where all anodes and all cathodes are connected in parallel. In such monopolar electrolyzers, the operation takes place at high amperage and low voltage. In some embodiments, the electrolyzers provided herein are bipolar electrolyzers. In the bipolar electrolyzers, the electrodes may be connected in series where all anodes and all cathodes are connected in series. In such bipolar electrolyzers, the operation takes place at low amperage and high voltage. In some embodiments, the electrolyzers are a combination of monopolar and bipolar electrolyzers and may be called hybrid electrolyzers.

[140] In some embodiments of the bipolar electrolyzers as described above, the cells are stacked serially constituting the overall electrolyzer and are electrically connected in two ways. In bipolar electrolyzers, a single plate, called bipolar plate, may serve as base plate for both the cathode and anode. The electrolyte solution may be hydraulically connected through common manifolds and collectors internal to the cell stack. The stack may be compressed

externally to seal all frames and plates against each other which is typically referred to as a filter press design. In some embodiments, the bipolar electrolyzer may also be designed as a series of cells, individually sealed, and electrically connected through back-to-back contact, typically known as a single element design. The single element design may also be connected in parallel in which case it would be a monopolar electrolyzer.

[141] In some embodiments, the cell size may be denoted by the active area dimensions. In some embodiments, the active area of the electrolyzers used herein may range from 0.5-1.5 meters tall and 0.4-3 meters wide. The individual compartment thicknesses may range from 0.5mm-50mm.

[142] The electrolyzers used in the methods and systems provided herein, are made from corrosion resistant materials. Variety of materials were tested in metal solutions such as copper and at varying temperatures, for corrosion testing. The materials include, but not limited to, polyvinylidene fluoride, viton, polyether ether ketone, fluorinated ethylene propylene, fiber-reinforced plastic, halar, ultem (PEI), perfluoroalkoxy, tefzel, tyvar, fibre-reinforced plastic-coated with derakane 441-400 resin, graphite, akot, tantalum, hastelloy C2000, titanium Gr.7, titanium Gr.2, or combinations thereof. In some embodiments, these materials can be used for making the electrochemical cells and/or its components including, but not limited to, tank materials, piping, heat exchangers, pumps, reactors, cell housings, cell frames, electrodes, instrumentation, valves, and all other balance of plant materials. In some embodiments, the material used for making the electrochemical cell and its components include, but not limited to, titanium Gr.2.

Metal

[143] The “metal ion” or “metal” or “metal ion in the metal halide” as used herein, includes any metal ion capable of being converted from lower oxidation state to higher oxidation state. Examples of metal ions in the metal halide include, but not limited to, iron, chromium, copper, tin, silver, cobalt, uranium, lead, mercury, vanadium, bismuth, titanium, ruthenium, osmium, europium, zinc, cadmium, gold, nickel, palladium, platinum, rhodium, iridium, manganese, technetium, rhenium, molybdenum, tungsten, niobium, tantalum, zirconium, hafnium, and combination thereof. In some embodiments, the metal ions include, but not limited to, iron, copper, tin, chromium, or combination thereof. In some embodiments, the metal ion is copper. In some embodiments, the metal ion is tin. In some embodiments, the metal ion is iron. In some embodiments, the metal ion is chromium. In some embodiments, the metal ion is platinum. The “oxidation state” as used herein, includes degree of oxidation of an atom in a substance. For example, in some embodiments, the

oxidation state is the net charge on the ion. Some examples of the reaction of the metal ions at the anode are as shown in **Table I** below (SHE is standard hydrogen electrode). The theoretical values of the anode potential are also shown. It is to be understood that some variation from these voltages may occur depending on conditions, pH, concentrations of the electrolytes, etc and such variations are well within the scope of the invention.

Table I

Anode Reaction	Anode Potential (V vs. SHE)
$\text{Ag}^+ \rightarrow \text{Ag}^{2+} + \text{e}^-$	-1.98
$\text{Co}^{2+} \rightarrow \text{Co}^{3+} + \text{e}^-$	-1.82
$\text{Pb}^{2+} \rightarrow \text{Pb}^{4+} + 2\text{e}^-$	-1.69
$\text{Ce}^{3+} \rightarrow \text{Ce}^{4+} + \text{e}^-$	-1.44
$2\text{Cr}^{3+} + 7\text{H}_2\text{O} \rightarrow \text{Cr}_2\text{O}_7^{2-} + 14\text{H}^+ + 6\text{e}^-$	-1.33
$\text{Ti}^+ \rightarrow \text{Ti}^{3+} + 2\text{e}^-$	-1.25
$\text{Hg}_2^{2+} \rightarrow 2\text{Hg}^{2+} + 2\text{e}^-$	-0.91
$\text{Fe}^{2+} \rightarrow \text{Fe}^{3+} + \text{e}^-$	-0.77
$\text{V}^{3+} + \text{H}_2\text{O} \rightarrow \text{VO}^{2+} + 2\text{H}^+ + \text{e}^-$	-0.34
$\text{U}^{4+} + 2\text{H}_2\text{O} \rightarrow \text{UO}_2^{2+} + 4\text{H}^+ + \text{e}^-$	-0.27
$\text{Bi}^+ \rightarrow \text{Bi}^{3+} + 2\text{e}^-$	-0.20
$\text{Ti}^{3+} + \text{H}_2\text{O} \rightarrow \text{TlO}^{2+} + 2\text{H}^+ + \text{e}^-$	-0.19
$\text{Cu}^+ \rightarrow \text{Cu}^{2+} + \text{e}^-$	-0.16
$\text{UO}_2^+ \rightarrow \text{UO}_2^{2+} + \text{e}^-$	-0.16
$\text{Sn}^{2+} \rightarrow \text{Sn}^{4+} + 2\text{e}^-$	-0.15
$\text{Ru}(\text{NH}_3)_6^{2+} \rightarrow \text{Ru}(\text{NH}_3)_6^{3+} + \text{e}^-$	-0.10
$\text{V}^{2+} \rightarrow \text{V}^{3+} + \text{e}^-$	+0.26
$\text{Eu}^{2+} \rightarrow \text{Eu}^{3+} + \text{e}^-$	+0.35
$\text{Cr}^{2+} \rightarrow \text{Cr}^{3+} + \text{e}^-$	+0.42
$\text{U}^{3+} \rightarrow \text{U}^{4+} + \text{e}^-$	+0.52

[144] The metal halide may be present as a compound of the metal or an alloy of the metal or combination thereof. In some embodiments, the anion attached to the metal is same as the anion of the electrolyte. For example, for sodium or potassium chloride used as an electrolyte, a metal chloride, such as, but not limited to, iron chloride, copper chloride, tin chloride, chromium chloride etc. is used as the metal compound. For example, for sodium or potassium bromide used as an electrolyte, a metal bromide, such as, but not limited to, iron bromide, copper bromide, tin bromide etc. is used as the metal compound.

[145] In some embodiments, the anion of the electrolyte may be partially or fully different from the anion of the metal. For example, in some embodiments, the anion of the electrolyte may be a sulfate whereas the anion of the metal may be a chloride. In such embodiments, it may be desirable to have less concentration of the chloride ions in the electrochemical cell. In some embodiments, the anode electrolyte may be a combination of ions similar to the metal anion and anions different from the metal ion. For example, the anode electrolyte may be a mix of sulfate ions as well as chloride ions when the metal anion is chloride. In such

embodiments, it may be desirable to have sufficient concentration of chloride ions in the electrolyte to dissolve the metal salt but not high enough to cause undesirable ionic speciation.

[146] In some embodiments, the electrolyte and/or the metal compound are chosen based on the desired end product. For example, if a brominated product is desired from the reaction between the metal compound and the ethylene or ethane, then a metal bromide is used as the metal compound and the sodium or potassium bromide is used as the electrolyte. In some embodiments, the metal ions of the metal halide used in the electrochemical systems described herein, may be chosen based on the solubility of the metal in the anode electrolyte and/or cell voltages desired for the metal oxidation from the lower oxidation state to the higher oxidation state.

[147] It is to be understood that the metal halide with the metal ion in the lower oxidation state and the metal halide with the metal ion in the higher oxidation state are both present in the anode electrolyte. The anode electrolyte exiting the anode chamber contains higher amount of the metal halide in the higher oxidation state than the amount of the metal halide in the higher oxidation state entering the anode chamber. Owing to the oxidation of the metal halide from the lower oxidation state to the higher oxidation state at the anode, the ratio of the metal halide in the lower and the higher oxidation state is different in the anode electrolyte entering the anode chamber and exiting the anode chamber. Suitable ratios of the metal ion in the lower and higher oxidation state in the anode electrolyte have been described herein. The mixed metal ion in the lower oxidation state with the metal ion in the higher oxidation state may assist in lower voltages in the electrochemical systems and high yield and selectivity in corresponding catalytic reactions with the ethylene or ethane.

[148] In some embodiments, the metal ion in the anode electrolyte is a mixed metal ion. For example, the anode electrolyte containing the copper ion in the lower oxidation state and the copper ion in the higher oxidation state may also contain another metal ion such as, but not limited to, iron. In some embodiments, the presence of a second metal ion in the anode electrolyte may be beneficial in lowering the total energy of the electrochemical reaction in combination with the catalytic reaction.

[149] Some examples of the metal compounds or metal halides that may be used in the systems and methods of the invention include, but are not limited to, copper (I) chloride, copper (I) bromide, copper (I) iodide, iron (II) chloride, iron (II) bromide, iron (II) iodide, tin (II) chloride, tin (II) bromide, tin (II) iodide, chromium (II) chloride, chromium (II) bromide, chromium (II) iodide, zinc (II) chloride, zinc (II) bromide, etc.

Ligand

[150] In some embodiments, an additive such as a ligand is used in conjunction with the metal ion to improve the efficiency of the metal ion oxidation inside the anode chamber and/or improve the catalytic reactions of the metal ion inside/outside the anode chamber such as, but not limited to reactions with ethylene or ethane. In some embodiments, the ligand is added along with the metal halide in the anode electrolyte. In some embodiments, the ligand interacts with the metal ion in the higher oxidation state, or with the metal ion in the lower oxidation state, or both. In some embodiments, the ligand is attached to the metal ion of the metal halide. In some embodiments, the ligand is attached to the metal ion by covalent, ionic and/or coordinate bonds. In some embodiments, the ligand is attached to the metal ion of the metal halide through vanderwaal attractions.

[151] In some embodiments, the ligand results in one or more of the following: enhanced reactivity of the metal ion towards the ethylene or ethane, enhanced selectivity of the metal ion towards halogenations of the ethylene or ethane, enhanced transfer of the halogen from the metal halide to the ethylene or ethane, reduced redox potential of the electrochemical cell, enhanced solubility of the metal halide in the aqueous medium, reduced membrane cross-over of the metal halide to the cathode electrolyte in the electrochemical cell, reduced corrosion of the electrochemical cell and/or the reactor, enhanced separation of the metal ion from the organic solution after reaction with ethylene or ethane, enhanced separation of the metal ion from the one or more organic compounds (such as adsorbents), and combination thereof.

[152] In some embodiments, the attachment of the ligand to the metal ion increases the size of the metal ion sufficiently higher to prevent its migration through the ion exchange membranes in the cell. In some embodiments, the anion exchange membrane in the electrochemical cell is such that the migration of the metal ion attached to the ligand from the anode electrolyte to the cathode electrolyte, is prevented. Such membranes are described herein below. In some embodiments, the anion exchange membrane in the electrochemical cell may be used in conjunction with the size exclusion membrane such that the migration of the metal ion attached to the ligand from the anode electrolyte to the cathode electrolyte, is prevented. In some embodiments, the attachment of the ligand to the metal ion increases the solubility of the metal ion in the aqueous medium. In some embodiments, the attachment of the ligand to the metal ion reduces the corrosion of the metals in the electrochemical cell as well as the reactor. In some embodiments, the attachment of the ligand to the metal ion increases the size of the metal ion sufficiently higher to facilitate separation of the metal ion

from the one or more organic compounds or enantiomers thereof after the reaction. In some embodiments, the presence and/or attachment of the ligand to the metal ion may prevent formation of various halogenated species of the metal ion in the solution and favor formation of only the desired species. For example, the presence of the ligand in the copper ion solution may limit the formation of the various halogenated species of the copper ion, such as, but not limited to, $[\text{CuCl}_3]^{2-}$ or CuCl_2^0 but favor formation of $\text{Cu}^{2+}/\text{Cu}^+$ ion. In some embodiments, the presence and/or attachment of the ligand in the metal ion solution reduces the overall voltage of the cell by providing one or more of the advantages described above.

[153] The “ligand” as used herein includes any ligand capable of enhancing the properties of the metal ion. In some embodiments, ligands include, but not limited to, substituted or unsubstituted aliphatic phosphine, substituted or unsubstituted aromatic phosphine, substituted or unsubstituted amino phosphine, substituted or unsubstituted crown ether, substituted or unsubstituted aliphatic nitrogen, substituted or unsubstituted cyclic nitrogen, substituted or unsubstituted aliphatic sulfur, substituted or unsubstituted cyclic sulfur, substituted or unsubstituted heterocyclic, and substituted or unsubstituted heteroaromatic.

[154] The ligands are described in detail in US Patent Application Serial No. 13/799,131, filed March 13, 2013.

[155] In some embodiments, the concentration of the ligand in the electrochemical cell is dependent on the concentration of the metal ion in the lower and/or the higher oxidation state. In some embodiments, the concentration of the ligand is between 0.25M-5M; or between 0.25M-4M; or between 0.25M-3M; or between 0.5M-5M; or between 0.5M-4M; or between 0.5M-3M; or between 0.5M-2.5M; or between 0.5M-2M; or between 0.5M-1.5M; or between 0.5M-1M; or between 1M-2M; or between 1.5M-2.5M; or between 1.5M-2M.

[156] In some embodiments, the ratio of the concentration of the ligand and the concentration of the metal ion such as, Cu(I) ion is between 1:1 to 4:1; or between 1:1 to 3:1; or between 1:1 to 2:1; or is 1:1; or 2:1, or 3:1, or 4:1.

[157] In some embodiments, the solution used in the catalytic reaction, i.e., the reaction of the metal ion in the higher oxidation state with the ethylene or ethane, and the solution used in the electrochemical reaction, contain the concentration of the metal ion in the higher oxidation state, such as Cu(II), between 4M-8M, the concentration of the metal ion in the lower oxidation state, such as Cu(I), between 0.25M-2M, and the concentration of the ligand between 0.25M-6M. In some embodiments, the concentration of the alkali metal ions, such as, but not limited to, sodium chloride in the solution may affect the solubility of the ligand and/or the metal ion; the yield and selectivity of the catalytic reaction; and/or the efficiency

of the electrochemical cell. Accordingly, in some embodiments, the concentration of sodium chloride in the solution is between 1M-5M or between 1-3M. In some embodiments, the solution used in the catalytic reaction, i.e., the reaction of the metal ion in the higher oxidation state with the ethylene or ethane, and the solution used in the electrochemical reaction, contain the concentration of the metal ion in the higher oxidation state, such as Cu(II), between 4M-8M, the concentration of the metal ion in the lower oxidation state, such as Cu(I), between 0.25M-2M, the concentration of the ligand between 0.25M-6M, and the concentration of sodium chloride between 1M-5M.

Anode

[158] In some embodiments, the anode may contain a corrosion stable, electrically conductive base support. Such as, but not limited to, amorphous carbon, such as carbon black, fluorinated carbons like the specifically fluorinated carbons described in U.S. Pat. No. 4,908,198 and available under the trademark SFC™ carbons. Other examples of electrically conductive base materials include, but not limited to, sub-stoichiometric titanium oxides, such as, Magneli phase sub-stoichiometric titanium oxides having the formula TiO_x wherein x ranges from about 1.67 to about 1.9. Some examples of titanium sub-oxides include, without limitation, titanium oxide Ti_4O_7 . The electrically conductive base materials also include, without limitation, metal titanates such as $M_xTi_yO_z$ such as $M_xTi_4O_7$, etc. In some embodiments, carbon based materials provide a mechanical support or as blending materials to enhance electrical conductivity but may not be used as catalyst support to prevent corrosion.

[159] In some embodiments, the anode is not coated with an electrocatalyst. In some embodiments, the gas-diffusion electrodes or general electrodes described herein (including anode and/or cathode) contain an electrocatalyst for aiding in electrochemical dissociation, e.g. reduction of oxygen at the cathode or the oxidation of the metal ion at the anode. Examples of electrocatalysts include, but not limited to, highly dispersed metals or alloys of the platinum group metals, such as platinum, palladium, ruthenium, rhodium, iridium, or their combinations such as platinum-rhodium, platinum-ruthenium, titanium mesh coated with PtIr mixed metal oxide or titanium coated with galvanized platinum; electrocatalytic metal oxides, such as, but not limited to, IrO_2 ; gold, tantalum, carbon, graphite, organometallic macrocyclic compounds, and other electrocatalysts well known in the art for electrochemical reduction of oxygen or oxidation of metal.

[160] In some embodiments, the electrodes described herein, relate to porous homogeneous composite structures as well as heterogeneous, layered type composite structures wherein

each layer may have a distinct physical and compositional make-up, e.g. porosity and electroconductive base to prevent flooding, and loss of the three phase interface, and resulting electrode performance.

[161] In some embodiments, the electrodes provided herein may include anodes and cathodes having porous polymeric layers on or adjacent to the anolyte or catholyte solution side of the electrode which may assist in decreasing penetration and electrode fouling. Stable polymeric resins or films may be included in a composite electrode layer adjacent to the anolyte comprising resins formed from non-ionic polymers, such as polystyrene, polyvinyl chloride, polysulfone, etc., or ionic-type charged polymers like those formed from polystyrenesulfonic acid, sulfonated copolymers of styrene and vinylbenzene, carboxylated polymer derivatives, sulfonated or carboxylated polymers having partially or totally fluorinated hydrocarbon chains and aminated polymers like polyvinylpyridine. Stable microporous polymer films may also be included on the dry side to inhibit electrolyte penetration. In some embodiments, the gas-diffusion cathodes includes such cathodes known in the art that are coated with high surface area coatings of precious metals such as gold and/or silver, precious metal alloys, nickel, and the like.

[162] In some embodiments, the methods and systems provided herein include anode that allows increased diffusion of the electrolyte in and around the anode. The shape and/or geometry of the anode may have an effect on the flow or the velocity of the anode electrolyte around the anode in the anode chamber which in turn may improve the mass transfer and reduce the voltage of the cell. In some embodiments, the methods and systems provided herein include anode that is a “diffusion enhancing” anode. The “diffusion enhancing” anode as used herein includes anode that enhances the diffusion of the electrolyte in and/or around the anode thereby enhancing the reaction at the anode. In some embodiments, the diffusion enhancing anode is a porous anode. The “porous anode” as used herein includes an anode that has pores in it. The diffusion enhancing anode such as, but not limited to, the porous anode used in the methods and systems provided herein, may have several advantages over the non-diffusing or non-porous anode in the electrochemical systems including, but not limited to, higher surface area; increase in active sites; decrease in voltage; decrease or elimination of resistance by the anode electrolyte; increase in current density; increase in turbulence in the anode electrolyte; and/or improved mass transfer.

[163] The diffusion enhancing anode such as, but not limited to, the porous anode may be flat, unflat, or combinations thereof. For example, in some embodiments, the diffusion enhancing anode such as, but not limited to, the porous anode is in a flat form including, but

not limited to, an expanded flattened form, a perforated plate, a reticulated structure, etc. In some embodiments, the diffusion enhancing anode such as, but not limited to, the porous anode includes an expanded mesh or is a flat expanded mesh anode.

[164] In some embodiments, the diffusion enhancing anode such as, but not limited to, the porous anode is unflat or has a corrugated geometry. In some embodiments, the corrugated geometry of the anode may provide an additional advantage of the turbulence to the anode electrolyte and improve the mass transfer at the anode. The “corrugation” or “corrugated geometry” or “corrugated anode” as used herein includes an anode that is not flat or is unflat. The corrugated geometry of the anode includes, but not limited to, unflattened, expanded unflattened, staircase, undulations, wave like, 3-D, crimp, groove, pleat, pucker, ridge, ruche, ruffle, wrinkle, woven mesh, punched tab style, etc.

[165] Few examples of the flat and the corrugated geometry of the diffusion enhancing anode such as, but not limited to, the porous anode are as illustrated in **Fig. 6**. These examples are for illustration purposes only and any other variation from these geometries is well within the scope of the invention. The figure A in **Fig. 6** is an example of a flat expanded anode and the figure B in **Fig. 6** is an example of the corrugated anode.

[166] In some embodiments of the foregoing methods and embodiments, the use of the diffusion enhancing anode such as, but not limited to, the porous anode results in the voltage savings of between 10-500mV, or between 50-250mV, or between 100-200mV, or between 200-400mV, or between 25-450mV, or between 250-350mV, or between 100-500mV, as compared to the non-diffusing or the non-porous anode.

[167] In some embodiments of the foregoing methods and embodiments, the use of the corrugated anode results in the voltage savings of between 10-500mV, or between 50-250mV, or between 100-200mV, or between 200-400mV, or between 25-450mV, or between 250-350mV, or between 100-500mV, as compared to the flat porous anode.

[168] The diffusion enhancing anode such as, but not limited to, the porous anode may be characterized by various parameters including, but not limited to, mesh number which is a number of lines of mesh per inch; pore size; thickness of the wire or wire diameter; percentage open area; amplitude of the corrugation; repetition period of the corrugation, etc. These characteristics of the diffusion enhancing anode such as, but not limited to, the porous anode may affect the properties of the porous anode, such as, but not limited to, increase in the surface area for the anode reaction; reduction of solution resistance; reduction of voltage applied across the anode and the cathode; enhancement of the electrolyte turbulence across the anode; and/or improved mass transfer at the anode.

[169] In some embodiments of the foregoing methods and embodiments, the diffusion enhancing anode such as, but not limited to, the porous anode may have a pore opening size (as illustrated in **Fig. 6**) ranging between 2x1mm to 20x10mm; or between 2x1mm to 10x5mm; or between 2x1mm to 5x5mm; or between 1x1mm to 20x10mm; or between 1x1mm to 10x5mm; or between 1x1mm to 5x5mm; or between 5x1mm to 10x5mm; or between 5x1mm to 20x10mm; between 10x5mm to 20x10mm and the like. It is to be understood that the pore size of the porous anode may also be dependent on the geometry of the pore. For example, the geometry of the pore may be diamond shaped or square shaped. For the diamond shaped geometry, the pore size may be, e.g., 3x10mm with 3 mm being widthwise and 10mm being lengthwise of the diamond, or vice versa. For the square shaped geometry, the pore size would be, e.g., 3mm each side. The woven mesh may be the mesh with square shaped pores and the expanded mesh may be the mesh with diamond shaped pores.

[170] In some embodiments of the foregoing methods and embodiments, the diffusion enhancing anode such as, but not limited to, the porous anode may have a pore wire thickness or mesh thickness (as illustrated in **Fig. 6**) ranging between 0.5mm to 5mm; or between 0.5mm to 4mm; or between 0.5mm to 3mm; or between 0.5mm to 2mm; or between 0.5mm to 1mm; or between 1mm to 5mm; or between 1mm to 4mm; or between 1mm to 3mm; or between 1mm to 2mm; or between 2mm to 5mm; or between 2mm to 4mm; or between 2mm to 3mm; or between 0.5mm to 2.5mm; or between 0.5mm to 1.5mm; or between 1mm to 1.5mm; or between 1mm to 2.5mm; or between 2.5mm to 3mm; or 0.5mm; or 1mm; or 2mm; or 3mm.

[171] In some embodiments of the foregoing methods and embodiments, when the diffusion enhancing anode such as, but not limited to, the porous anode is the corrugated anode, then the corrugated anode may have a corrugation amplitude (as illustrated in **Fig. 6**) ranging between 1mm to 8mm; or between 1mm to 7mm; or between 1mm to 6mm; or between 1mm to 5mm; or between 1mm to 4mm; or between 1mm to 4.5mm; or between 1mm to 3mm; or between 1mm to 2mm; or between 2mm to 8mm; or between 2mm to 6mm; or between 2mm to 4mm; or between 2mm to 3mm; or between 3mm to 8mm; or between 3mm to 7mm; or between 3mm to 5mm; or between 3mm to 4mm; or between 4mm to 8mm; or between 4mm to 5mm; or between 5mm to 7mm; or between 5mm to 8mm.

[172] In some embodiments of the foregoing methods and embodiments, when the diffusion enhancing anode such as, but not limited to, the porous anode is the corrugated anode, then the corrugated anode may have a corrugation period (not illustrated in figures)

ranging between 2mm to 35mm; or between 2mm to 32mm; or between 2mm to 30mm; or between 2mm to 25mm; or between 2mm to 20mm; or between 2mm to 16mm; or between 2mm to 10mm; or between 5mm to 35mm; or between 5mm to 30mm; or between 5mm to 25mm; or between 5mm to 20mm; or between 5mm to 16mm; or between 5mm to 10mm; or between 15mm to 35mm; or between 15mm to 30mm; or between 15mm to 25mm; or between 15mm to 20mm; or between 20mm to 35mm; or between 25mm to 30mm; or between 25mm to 35mm; or between 25mm to 30mm.

[173] In some embodiments, the diffusion enhancing anode such as, but not limited to, the porous anode is made of an electro conductive base metal such as titanium coated with or without electrocatalysts. Some examples of electrically conductive base materials include, but not limited to, sub-stoichiometric titanium oxides, such as, Magneli phase sub-stoichiometric titanium oxides having the formula TiO_x wherein x ranges from about 1.67 to about 1.9. Some examples of titanium sub-oxides include, without limitation, titanium oxide Ti_4O_7 . The electrically conductive base materials also include, without limitation, metal titanates such as $M_xTi_yO_z$ such as $M_xTi_4O_7$, etc. Examples of electrocatalysts have been described herein and include, but not limited to, highly dispersed metals or alloys of the platinum group metals, such as platinum, palladium, ruthenium, rhodium, iridium, or their combinations such as platinum-rhodium, platinum-ruthenium, titanium mesh coated with PtIr mixed metal oxide or titanium coated with galvanized platinum; electrocatalytic metal oxides, such as, but not limited to, IrO_2 ; gold, tantalum, carbon, graphite, organometallic macrocyclic compounds, and other electrocatalysts well known in the art. The diffusion enhancing anode such as, but not limited to, the porous anode may be commercially available or may be fabricated with appropriate metals. The electrodes may be coated with electrocatalysts using processes well known in the art. For example, the metal may be dipped in the catalytic solution for coating and may be subjected to processes such as heating, sand blasting etc. Such methods of fabricating the anodes and coating with catalysts are well known in the art.

[174] In some embodiments of the methods and systems described herein, a turbulence promoter is used in the anode compartment to improve mass transfer at the anode. For example, as the current density increases in the electrochemical cell, the mass transfer controlled reaction rate at the anode is achieved. The laminar flow of the anolyte may cause resistance and diffusion issues. In order to improve the mass transfer at the anode and thereby reduce the voltage of the cell, a turbulence promoter may be used in the anode compartment. A "turbulence promoter" as used herein includes a component in the anode compartment of the electrochemical cell that provides turbulence. In some embodiments, the

turbulence promoter may be provided at the back of the anode, i.e. between the anode and the wall of the electrochemical cell and/or in some embodiments, the turbulence promoter may be provided between the anode and the anion exchange membrane. For example only, the electrochemical systems provided herein, may have a turbulence promoter between the anode and the ion exchange membrane such as the anion exchange membrane and/or have the turbulence promoter between the anode and the outer wall of the cell.

[175] An example of the turbulence promoter is bubbling of the gas in the anode compartment. The gas can be any inert gas that does not react with the constituents of the anolyte. For example, the gas includes, but not limited to, air, nitrogen, argon, and the like. The bubbling of the gas at the anode can stir up the anode electrolyte and improve the mass transfer at the anode. The improved mass transfer can result in the reduced voltage of the cell. Other examples of the turbulence promoter include, but not limited to, incorporating a carbon cloth next to the anode, incorporating a carbon/graphite felt next to the anode, an expanded plastic next to the anode, a fishing net next to the anode, a combination of the foregoing, and the like.

Cathode

[176] Any of the cathodes provided herein can be used in combination with any of the anodes described above. In some embodiments, the cathode used in the electrochemical systems of the invention, is a hydrogen gas producing cathode.

[177] Following are the reactions that take place at the cathode and the anode:

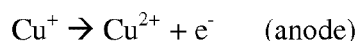
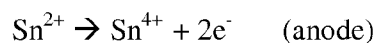
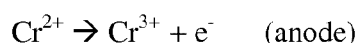
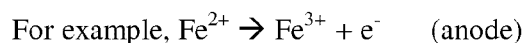
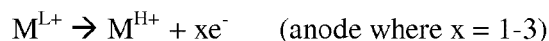
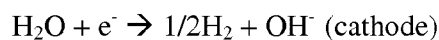

[178] The hydrogen gas formed at the cathode may be vented out or captured and stored for commercial purposes. The $\text{M}^{\text{H}+}$ formed at the anode combines with halide ions, e.g. chloride ions to form metal chloride in the higher oxidation state such as, but not limited to, FeCl_3 , CrCl_3 , SnCl_4 , or CuCl_2 etc. The hydroxide ion formed at the cathode combines with sodium ions to form sodium hydroxide. It is to be understood that chloride ions in this application are for illustration purposes only and that other equivalent ions such as, but not limited to, fluoride, bromide or iodide are also well within the scope of the invention and would result in corresponding metal halide in the anode electrolyte.

[179] In some embodiments, the cathode used in the electrochemical systems of the invention, is a hydrogen gas producing cathode that does not form an alkali. Following are the reactions that take place at the cathode and the anode:

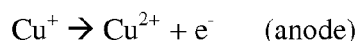
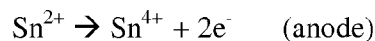
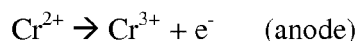
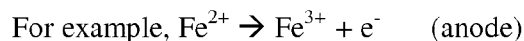
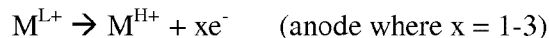
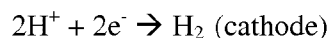

[180] The hydrogen gas may be vented out or captured and stored for commercial purposes. The $\text{M}^{\text{H}+}$ formed at the anode combines with halide ions, e.g. chloride ions to form metal chloride in the higher oxidation state such as, but not limited to, FeCl_3 , CrCl_3 , SnCl_4 , or CuCl_2 etc.

[181] In some embodiments, the cathode in the electrochemical systems of the invention may be a gas-diffusion cathode. In some embodiments, the cathode in the electrochemical systems of the invention may be a gas-diffusion cathode forming an alkali at the cathode. As used herein, the “gas-diffusion cathode,” or “gas-diffusion electrode,” or other equivalents thereof include any electrode capable of reacting a gas to form ionic species. In some embodiments, the gas-diffusion cathode, as used herein, is an oxygen depolarized cathode (ODC). Such gas-diffusion cathode may be called gas-diffusion electrode, oxygen consuming cathode, oxygen reducing cathode, oxygen breathing cathode, oxygen depolarized cathode, and the like.

[182] Following are the reactions that may take place at the anode and the cathode.

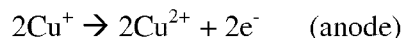
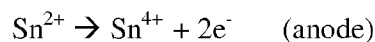
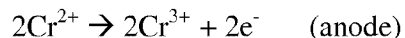
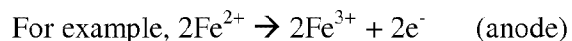
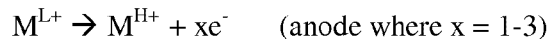
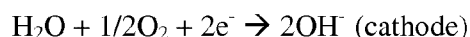

[183] The $\text{M}^{\text{H}+}$ formed at the anode combines with halide ions, e.g. chloride ions to form metal chloride MCl_n such as, but not limited to, FeCl_3 , CrCl_3 , SnCl_4 , or CuCl_2 etc. The hydroxide ion formed at the cathode reacts with sodium ions to form sodium hydroxide. The oxygen at the cathode may be atmospheric air or any commercial available source of oxygen.

[184] The methods and systems containing the gas-diffusion cathode or the ODC, as described herein may result in voltage savings as compared to methods and systems that include the hydrogen gas producing cathode. The voltage savings in-turn may result in less electricity consumption and less carbon dioxide emission for electricity generation.

[185] While the methods and systems containing the gas-diffusion cathode or the ODC result in voltage savings as compared to methods and systems containing the hydrogen gas producing cathode, both the systems i.e. systems containing the ODC and the systems containing hydrogen gas producing cathode of the invention, show significant voltage savings as compared to chlor-alkali system conventionally known in the art. The voltage savings in-turn may result in less electricity consumption and less carbon dioxide emission for electricity generation. In some embodiments, the electrochemical system of the invention (2 or 3-compartment cells with hydrogen gas producing cathode or ODC) has a theoretical voltage savings of more than 0.5V, or more than 1V, or more than 1.5V, or between 0.5-3V, as compared to chlor-alkali process. In some embodiments, this voltage saving is achieved with a cathode electrolyte pH of between 7-15, or between 7-14, or between 6-12, or between 7-12, or between 7-10.

[186] For example, theoretical E_{anode} in the chlor-alkali process is about 1.36V undergoing the reaction as follows:



[187] Theoretical E_{cathode} in the chlor-alkali process is about -0.83V (at pH >14) undergoing the reaction as follows:

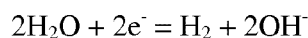

[188] Theoretical E_{total} for the chlor-alkali process then is 2.19V. Theoretical E_{total} for the hydrogen gas producing cathode in the system of the invention is between 0.989 to 1.53V and E_{total} for ODC in the system of the invention then is between -0.241 to 0.3V, depending on the concentration of copper ions in the anode electrolyte. Therefore, the electrochemical systems of the invention bring the theoretical voltage savings in the cathode chamber or the theoretical voltage savings in the cell of greater than 3V or greater than 2V or between 0.5-2.5V or between 0.5-2.0V or between 0.5-1.5V or between 0.5-1.0V or between 1-1.5V or between 1-2V or between 1-2.5V or between 1.5-2.5V, as compared to the chlor-alkali system.

[189] In some embodiments, the cathode in the electrochemical systems of the invention may be a gas-diffusion cathode that reacts HCl and oxygen gas to form water.

[190] Following are the reactions that may take place at the anode and the cathode.

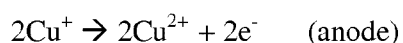
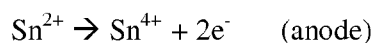
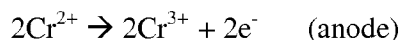
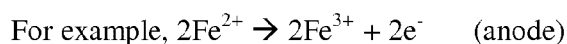
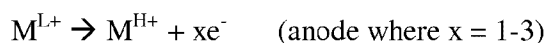
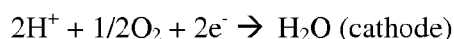

[191] The $\text{M}^{\text{H}+}$ formed at the anode combines with chloride ions to form metal chloride MCl_n such as, but not limited to, FeCl_3 , CrCl_3 , SnCl_4 , or CuCl_2 etc. The oxygen at the cathode may be atmospheric air or any commercial available source of oxygen.

Alkali in the cathode chamber

[192] The cathode electrolyte containing the alkali maybe withdrawn from the cathode chamber. In some embodiments, the alkali produced in the methods and systems provided herein is used as is commercially or is used in commercial processes known in the art. The purity of the alkali formed in the methods and systems may vary depending on the end use requirements. For example, methods and systems provided herein that use an electrochemical cell equipped with membranes may form a membrane quality alkali which may be substantially free of impurities. In some embodiments, a less pure alkali may also be formed by avoiding the use of membranes or by adding the carbon to the cathode electrolyte. In some embodiments, the alkali may be separated from the cathode electrolyte using techniques known in the art, including but not limited to, diffusion dialysis. In some embodiments, the alkali formed in the cathode electrolyte is more than 2% w/w or more than 5% w/w or between 5-50% w/w.

[193] In some embodiments, the systems include a collector configured to collect the alkali from the cathode chamber and connect it to the appropriate process which may be any means to collect and process the alkali including, but not limited to, tanks, collectors, pipes etc. that can collect, process, and/or transfer the alkali produced in the cathode chamber for use in the various commercial processes.

[194] In some embodiments, the alkali formed in the cathode electrolyte is used in making products such as, but not limited to carbonates and/or bicarbonates by contacting the carbon dioxide with the alkali. Such contact of the carbon dioxide, the sources of the carbon dioxide, and the formation of carbonate and/or bicarbonate products, is fully described in US Patent Application No. 13/799,131, filed March 13, 2013.

Ion Exchange Membrane

[195] In some embodiments, the cathode electrolyte and the anode electrolyte are separated in part or in full by an ion exchange membrane. In some embodiments, the ion exchange membrane is an anion exchange membrane or a cation exchange membrane. In some embodiments, the cation exchange membranes in the electrochemical cell, as disclosed herein, are conventional and are available from, for example, Asahi Kasei of Tokyo, Japan; or from Membrane International of Glen Rock, NJ, or DuPont, in the USA. Examples of CEM include, but are not limited to, N2030WX (Dupont), F8020/F8080 (Flemion), and F6801 (Aciplex). CEMs that are desirable in the methods and systems of the invention have minimal resistance loss, greater than 90% selectivity, and high stability in concentrated caustic. AEMs, in the methods and systems of the invention are exposed to concentrated metallic salt anolytes and saturated brine stream. It is desirable for the AEM to allow passage of salt ion such as chloride ion to the anolyte but reject the metallic ion species from the anolyte (**Fig. 5A**). In some embodiments, metallic salts may form various ion species (cationic, anionic, and/or neutral) including but not limited to, MCl^+ , MCl_2^- , MCl_2^0 , M^{2+} etc. and it is desirable for such complexes to not pass through AEM or not foul the membranes.

[196] In some embodiments, the AEM used in the methods and systems provided herein, is also substantially resistant to the organic compounds such that AEM does not interact with the organics and/or the AEM does not react or absorb metal ions. In some embodiments, this can be achieved, for example only, by using a polymer that does not contain a free radical or anion available for reaction with organics or with metal ions. For example only, a fully quarternized amine containing polymer may be used as an AEM.

[197] In some embodiments, the membranes used in the methods and systems provided herein are ionomer membranes reinforced with a material for reinforcement and are of a certain thickness. For example, in some embodiments, the thickness of the membrane is between 20-130 μm ; or between 20-110 μm ; or between 20-110 μm ; or between 20-80 μm ; or between 20-75 μm ; or between 20-60 μm ; or between 20-50 μm ; or between 20-40 μm ; or between 20-35 μm . In some embodiments, the membrane may be reinforced with materials such as, but not limited to, polymers, such as, polyethylene (PET), polypropylene (PP), and polyether ether ketone (PK), and glass fibers (GF). It is understood that other polymers that may be used for reinforcement of the AEM are well within the scope of the invention. In some embodiments, the membranes used in the methods and systems provided herein can withstand high temperatures, such as, but not limited to, temperatures higher than 70°C, for example between 70-200°C; or between 70-175°C; or between 70-150°C; or between 70-

100°C. Some of the membranes sold by FumaTech in Fumasep series may be used in the methods and systems provided herein. The examples, include, but not limited to, FAS-PK-130, FAS-PK-75, FAS-PK-50, FAS-PP-20, FAS-PP-130, FAS-PP-75, FAS-PP-50, FAS-PP-20, FAS-PET-130, FAS-PET-75, FAS-PET-50, FAS-PET-20, FAS-GF-75, FAS-GF-50, FAS-GF-20, FAA-PK-130, FAA-PK-75, FAA-PK-50, FAA-PP-20, FAS-PP-130, FAA-PP-75, FAA-PP-50, FAA-PP-20, FAA-PET-130, FAA-PET-75, FAA-PET-50, FAA-PET-20, FAA-GF-75, FAA-GF-50, FAA-GF-20. In some embodiments, the membrane used in the methods and systems of the invention has thickness between 20-75um, such as, e.g. FAA-PP-75. The nomenclature of the aforementioned membranes includes FAA or FAS-reinforcement material-thickness.

[198] In some embodiments of the aforementioned methods and embodiments, the anion exchange membrane rejects more than 80%, or more than 90%, or more than 99%, or about 99.9% of all metal ions from the anode electrolyte passing into the third electrolyte or the brine compartment or the cathode electrolyte. In some embodiments, the anion exchange membrane operates at temperatures greater than 70°C.

[199] Examples of cationic exchange membranes include, but not limited to, cationic membrane consisting of a perfluorinated polymer containing anionic groups, for example sulphonic and/or carboxylic groups. However, it may be appreciated that in some embodiments, depending on the need to restrict or allow migration of a specific cation or an anion species between the electrolytes, a cation exchange membrane that is more restrictive and thus allows migration of one species of cations while restricting the migration of another species of cations may be used as, e.g., a cation exchange membrane that allows migration of sodium ions into the cathode electrolyte from the anode electrolyte while restricting migration of other ions from the anode electrolyte into the cathode electrolyte, may be used (**Fig. 5B**). Similarly, in some embodiments, depending on the need to restrict or allow migration of a specific anion species between the electrolytes, an anion exchange membrane that is more restrictive and thus allows migration of one species of anions while restricting the migration of another species of anions may be used as, e.g., an anion exchange membrane that allows migration of chloride ions into the anode electrolyte from the cathode electrolyte while restricting migration of hydroxide ions from the cathode electrolyte into the anode electrolyte, may be used. Such restrictive cation exchange membranes are commercially available and can be selected by one ordinarily skilled in the art.

[200] In some embodiments, the membranes may be selected such that they can function in an acidic and/or basic electrolytic solution as appropriate. Other desirable characteristics of

the membranes include high ion selectivity, low ionic resistance, high burst strength, and high stability in an acidic electrolytic solution in a temperature range of room temperature to 150°C or higher, or a alkaline solution in similar temperature range may be used. In some embodiments, it is desirable that the ion exchange membrane prevents the transport of the metal ion from the anolyte to the catholyte. In some embodiments, a membrane that is stable in the range of 0°C to 150°C; 0°C to 90°C; or 0°C to 80°C; or 0°C to 70°C; or 0°C to 60°C; or 0°C to 50°C; or 0°C to 40°C, or 0°C to 30°C, or 0°C to 20°C, or 0°C to 10°C, or higher may be used. For other embodiments, it may be useful to utilize an ion-specific ion exchange membranes that allows migration of one type of cation but not another; or migration of one type of anion and not another, to achieve a desired product or products in an electrolyte. In some embodiments, the membrane may be stable and functional for a desirable length of time in the system, e.g., several days, weeks or months or years at temperatures in the range of 0°C to 90°C. In some embodiments, for example, the membranes may be stable and functional for at least 1 day, at least 5 days, 10 days, 15 days, 20 days, 100 days, 1000 days, 5-10 years, or more in electrolyte temperatures at 100°C, 90°C, 80°C, 70°C, 60°C, 50°C, 40°C, 30°C, 20°C, 10°C, 5°C and more or less.

[201] The ohmic resistance of the membranes may affect the voltage drop across the anode and cathode, e.g., as the ohmic resistance of the membranes increase, the voltage across the anode and cathode may increase, and vice versa. Membranes that can be used include, but are not limited to, membranes with relatively low ohmic resistance and relatively high ionic mobility; and membranes with relatively high hydration characteristics that increase with temperatures, and thus decreasing the ohmic resistance. By selecting membranes with lower ohmic resistance known in the art, the voltage drop across the anode and the cathode at a specified temperature can be lowered.

[202] Scattered through membranes may be ionic channels including acid groups. These ionic channels may extend from the internal surface of the matrix to the external surface and the acid groups may readily bind water in a reversible reaction as water-of-hydration. This binding of water as water-of-hydration may follow first order reaction kinetics, such that the rate of reaction is proportional to temperature. Consequently, membranes can be selected to provide a relatively low ohmic and ionic resistance while providing for improved strength and resistance in the system for a range of operating temperatures.

Electrolytes

[203] In the methods and systems described herein, the anode electrolyte containing the metal halide contains a mixture of the metal ion in the lower oxidation state and the metal ion in the higher oxidation state in saltwater solution (such as alkali metal halide solution e.g. sodium chloride aqueous solution). In some embodiments, the anode electrolyte that is contacted with the ethylene or ethane contains the metal ion in the lower oxidation state and the metal ion in the higher oxidation state. In some embodiments, the metal ion in the lower oxidation state and the metal ion in the higher oxidation state are present in a ratio such that the reaction of the metal ion with the ethylene or ethane to form one or more organic compounds or enantiomers thereof takes place. In some embodiments, the ratio of the metal ion in the higher oxidation state to the metal ion in the lower oxidation state is between 20:1 to 1:20, or between 14:1 to 1:2; or between 14:1 to 8:1; or between 14:1 to 7:1; or between 2:1 to 1:2; or between 1:1 to 1:2; or between 4:1 to 1:2; or between 7:1 to 1:2.

[204] In some embodiments of the methods and systems described herein, the anode electrolyte in the electrochemical systems and methods provided herein contains the metal ion in the higher oxidation state in the range of 4-8M, the metal ion in the lower oxidation state in the range of 0.1-2M and saltwater, such as alkali metal ions or alkaline earth metal ions, e.g. sodium chloride in the range of 1-5M. The anode electrolyte may optionally contain 0.01-0.1M hydrochloric acid. In some embodiments of the methods and systems described herein, the anode electrolyte reacted with the ethylene or ethane contains the metal ion in the higher oxidation state in the range of 4-7M, the metal ion in the lower oxidation state in the range of 0.1-2M and sodium chloride in the range of 1-3M. The concentration of the metal halide in the higher oxidation state is higher for the formation of TCA as compared to the formation of CE, as described herein. The anode electrolyte may optionally contain 0.01-0.1M hydrochloric acid.

[205] In some embodiments, the anode electrolyte may contain metal ion in the lower oxidation state and negligible or low amounts of the metal ion in the higher oxidation state for higher voltage efficiencies. The metal ion in the higher oxidation state may be supplemented to the exiting metal solution from the electrochemical cell before being fed into the reactor for the reaction with the ethylene or ethane. Before the metal ion solution is circulated back to the electrochemical cell from the reactor, the metal ion in the higher oxidation state may be removed or separated and the solution predominantly containing the metal ion in the lower oxidation state may be fed to the electrochemical cell. Such separation

and/or purification of the metal solution before and after the electrochemical cell has been described herein.

[206] In some embodiments of the methods and systems described herein, the anode electrolyte may contain saltwater such as but not limited to, water containing alkali metal or alkaline earth metal ions in addition to the metal ion. The alkaline metal ions and/or alkaline earth metal ions include such as but not limited to, lithium, sodium, potassium, calcium, magnesium, etc. The amount of the alkali metal or alkaline earth metal ions added to the anode electrolyte may be between 0.01-5M; between 0.01-4M; or between 0.01-3M; or between 0.01-2M; or between 0.01-1M; or between 1-5M; or between 1-4M; or between 1-3M; or between 1-2M; or between 2-5M; or between 2-4M; or between 2-3M; or between 3-5M.

[207] In some embodiments of the methods and systems described herein, the anode electrolyte may contain an acid. The acid may be added to the anode electrolyte to bring the pH of the anolyte to 1 or 2 or less. The acid may be hydrochloric acid or sulfuric acid.

[208] In some embodiments, the electrolyte in the electrochemical systems and methods described herein include the aqueous medium containing more than 5wt% water. In some embodiments, the aqueous medium includes more than 5wt% water; or more than 5.5wt% water; or more than 6wt%; or more than 20wt% water; or more than 25wt% water; or more than 50wt% water; or more than 80wt% water; or more than 90wt% water; or about 99wt% water; or between 5-100wt% water; or between 5-99wt% water; or between 5-90wt% water; or between 5-70wt% water; or between 5-50wt% water; or between 5-20wt% water; or between 5-10wt% water; or between 6-100wt% water; or between 6-99wt% water; or between 6-90wt% water; or between 6-50wt% water; or between 6-10wt% water; or between 10-100wt% water; or between 10-75wt% water; or between 10-50wt% water; or between 20-100wt% water; or between 25-60wt% water; or between 26-60wt% water; or between 25-50wt% water; or between 26-50wt% water; or between 25-45wt% water; or between 26-45wt% water; or between 20-50wt% water; or between 50-100wt% water; or between 50-75wt% water; or between 50-60wt% water; or between 70-100wt% water; or between 70-90wt% water; or between 80-100wt% water. In some embodiments, the aqueous medium may comprise a water soluble organic solvent.

[209] In some embodiments of the methods and systems described herein, the amount of total metal ion in the anode electrolyte or the amount of metal halide in the anode electrolyte or the amount of copper halide in the anode electrolyte or the amount of iron halide in the anode electrolyte or the amount of chromium halide in the anode electrolyte or the amount of

tin halide in the anode electrolyte or the amount of platinum halide or the amount of metal ion that is contacted with the ethylene or ethane is between 1-12M; or between 1-11M; or between 1-10M; or between 1-9M; or between 1-8M; or between 1-7M; or between 1-6M; or between 1-5M; or between 1-4M; or between 1-3M; or between 1-2M; or between 2-12M; or between 2-11M; or between 2-10M; or between 2-9M; or between 2-8M; or between 2-7M; or between 2-6M; or between 2-5M; or between 2-4M; or between 2-3M; or between 3-12M; or between 3-11M; or between 3-10M; or between 3-9M; or between 3-8M; or between 3-7M; or between 3-6M; or between 3-5M; or between 3-4M; or between 4-12M; or between 4-11M; or between 4-10M; or between 4-9M; or between 4-8M; or between 4-7M; or between 4-6M; or between 4-5M; or between 5-12M; or between 5-11M; or between 5-10M; or between 5-9M; or between 5-8M; or between 5-7M; or between 5-6M; or between 6-13M; or between 6-12M; or between 6-11M; or between 6-10M; or between 6-9M; or between 6-8M; or between 6-7M; or between 7-12M; or between 7-11M; or between 7-10M; or between 7-9M; or between 7-8M; or between 8-12M; or between 8-11M; or between 8-10M; or between 8-9M; or between 9-12M; or between 9-11M; or between 9-10M; or between 10-12M; or between 10-11M; or between 11-12M. In some embodiments, the amount of total ion in the anode electrolyte, as described above, is the amount of the metal ion in the lower oxidation state plus the amount of the metal ion in the higher oxidation state plus the alkali metal halide or alkaline earth metal halide; or the total amount of the metal ion in the higher oxidation state; or the total amount of the metal ion in the lower oxidation state.

[210] In some embodiments, in the electrochemical cell, the concentration of the metal ion in the lower oxidation state is between 0.5M to 2M or between 0.5M to 1M and the concentration of the metal ion in the higher oxidation state is between 4M to 7M. In some embodiments, in the reactor, the concentration of the metal ion in the lower oxidation state is between 0.5M to 2M or between 1M to 2M and the concentration of the metal ion in the higher oxidation state is between 4M to 6M. In some embodiments, in the electrochemical cell as well as in the reactor, the concentration of the metal ion in the lower oxidation state is between 0.5M to 2M and the concentration of the metal ion in the higher oxidation state is between 4M to 5M.

[211] In some embodiments, the aqueous electrolyte including the catholyte or the cathode electrolyte and/or the anolyte or the anode electrolyte, or the third electrolyte disposed between AEM and CEM, in the systems and methods provided herein include, but not limited to, saltwater or fresh water. The saltwater includes, but is not limited to, seawater, brine, and/or brackish water. In some embodiments, the cathode electrolyte in the systems and

methods provided herein include, but not limited to, seawater, freshwater, brine, brackish water, hydroxide, such as, sodium hydroxide, or combination thereof. "Saltwater" as used herein includes its conventional sense to refer to a number of different types of aqueous fluids other than fresh water, where the saltwater includes, but is not limited to, water containing alkali metal ions such as, sodium chloride, water containing alkaline earth metal ions such as, calcium chloride, brackish water, sea water and brine (including, naturally occurring subterranean brines or anthropogenic subterranean brines and man-made brines, *e.g.*, geothermal plant wastewaters, desalination waste waters, etc), as well as other salines having a salinity that is greater than that of freshwater. Brine is water saturated or nearly saturated with salt and has a salinity that is 50 ppt (parts per thousand) or greater. Brackish water is water that is saltier than fresh water, but not as salty as seawater, having a salinity ranging from 0.5 to 35 ppt. Seawater is water from a sea or ocean and has a salinity ranging from 35 to 50 ppt. The saltwater source may be a naturally occurring source, such as a sea, ocean, lake, swamp, estuary, lagoon, etc., or a man-made source. In some embodiments, the systems provided herein include the saltwater from terrestrial brine. In some embodiments, the depleted saltwater withdrawn from the electrochemical cells is replenished with salt and re-circulated back in the electrochemical cell.

[212] In some embodiments, the electrolyte including the cathode electrolyte and/or the anode electrolyte and/or the third electrolyte, such as, saltwater includes water containing alkali metal halides or alkaline earth metal halides of more than 1% chloride content, such as, NaCl; or more than 10% NaCl; or more than 50% NaCl; or more than 70% NaCl; or between 1-99% NaCl; or between 1-70% NaCl; or between 1-50% NaCl; or between 1-10% NaCl; or between 10-99% NaCl; or between 10-50% NaCl; or between 20-99% NaCl; or between 20-50% NaCl; or between 30-99% NaCl; or between 30-50% NaCl; or between 40-99% NaCl; or between 40-50% NaCl; or between 50-90% NaCl; or between 60-99% NaCl; or between 70-99% NaCl; or between 80-99% NaCl; or between 90-99% NaCl; or between 90-95% NaCl. In some embodiments, the above recited percentages apply to sodium fluoride, calcium chloride, ammonium chloride, metal chloride, sodium bromide, sodium iodide, etc. as an electrolyte. The percentages recited herein include wt% or wt/wt% or wt/v%. It is to be understood that all the electrochemical systems described herein that contain sodium chloride can be replaced with other suitable electrolytes, such as, but not limited to, ammonium chloride, sodium bromide, sodium iodide, or combination thereof.

[213] In some embodiments, the cathode electrolyte, such as, saltwater, fresh water, and/or sodium hydroxide do not include alkaline earth metal ions or divalent cations. As used

herein, the divalent cations include alkaline earth metal ions, such as but not limited to, calcium, magnesium, barium, strontium, radium, etc. In some embodiments, the cathode electrolyte, such as, saltwater, fresh water, and/or sodium hydroxide include less than 1% w/w divalent cations. In some embodiments, the cathode electrolyte, such as, seawater, freshwater, brine, brackish water, and/or sodium hydroxide include less than 1% w/w divalent cations including, but not limited to, calcium, magnesium, and combination thereof.

[214] In some embodiments, the anode electrolyte includes, but not limited to, fresh water and metal ions. In some embodiments, the anode electrolyte includes, but not limited to, saltwater and metal ions. In some embodiments, the anode electrolyte includes metal ion solution.

[215] In some embodiments, the depleted saltwater from the cell may be circulated back to the cell. In some embodiments, the cathode electrolyte includes 1-90%; 1-50%; or 1-40%; or 1-30%; or 1-15%; or 1-20%; or 1-10%; or 5-90%; or 5-50%; or 5-40%; or 5-30%; or 5-20%; or 5-10%; or 10-90%; or 10-50%; or 10-40%; or 10-30%; or 10-20%; or 15-20%; or 15-30%; or 20-30%, of the sodium hydroxide solution. In some embodiments, the anode electrolyte includes 1-5M; or 1-4.5M; or 1-4M; or 1-3.5M; or 1-3M; or 1-2.5M; or 1-2M; or 1-1.5M; or 2-5M; or 2-4.5M; or 2-4M; or 2-3.5M; or 2-3M; or 2-2.5M; or 3-5M; or 3-4.5M; or 3-4M; or 3-3.5M; or 4-5M; or 4.5-6M metal ion solution. In some embodiments, the anode does not form an oxygen gas. In some embodiments, the anode does not form a chlorine gas.

[216] Depending on the degree of alkalinity desired in the cathode electrolyte, the pH of the cathode electrolyte may be adjusted and in some embodiments is maintained between 6 and 12; or between 7 and 14 or greater; or between 7 and 13; or between 7 and 12; or between 7 and 11; or between 10 and 14 or greater; or between 10 and 13; or between 10 and 12; or between 10 and 11. In some embodiments, the pH of the cathode electrolyte may be adjusted to any value between 7 and 14 or greater, a pH less than 12, a pH 7.0, 7.5, 8.0, 8.5, 9.0, 9.5, 10.0, 10.5, 11.0, 11.5, 12.0, 12.5, 13.0, 13.5, 14.0, and/or greater.

[217] Similarly, in some embodiments of the system, the pH of the anode electrolyte is adjusted and is maintained between 0-7; or between 0-6; or between 0-5; or between 0-4; or between 0-3; or between 0-2; or between 0-1. As the voltage across the anode and cathode may be dependent on several factors including the difference in pH between the anode electrolyte and the cathode electrolyte (as can be determined by the Nernst equation well known in the art), in some embodiments, the pH of the anode electrolyte may be adjusted to a value between 0 and 7, including 0, 0.5, 1.0, 1.5, 2.0, 2.5, 3.0, 3.5, 4.0, 4.5, 5.0, 5.5, 6.0, 6.5 and 7, depending on the desired operating voltage across the anode and cathode. Thus, in

equivalent systems, where it is desired to reduce the energy used and/or the voltage across the anode and cathode, e.g., as in the chlor-alkali process, the carbon dioxide or a solution containing dissolved carbon dioxide can be added to the cathode electrolyte to achieve a desired pH difference between the anode electrolyte and cathode electrolyte.

[218] The system may be configured to produce any desired pH difference between the anode electrolyte and the cathode electrolyte by modulating the pH of the anode electrolyte, the pH of the cathode electrolyte, the concentration of hydroxide in the cathode electrolyte, the withdrawal and replenishment of the anode electrolyte, and/or the withdrawal and replenishment of the cathode electrolyte. By modulating the pH difference between the anode electrolyte and the cathode electrolyte, the voltage across the anode and the cathode can be modulated. In some embodiments, the system is configured to produce a pH difference of at least 4 pH units; at least 5 pH units; at least 6 pH units; at least 7 pH units; at least 8 pH units; at least 9 pH units; or between 4-12 pH units; or between 4-9 pH units; or between 3-12 pH units; or between 3-9 pH units; or between 5-12 pH units; or between 5-9 pH units; or between 6-12 pH units; or between 6-9 pH units; or between 7-12 pH units; or between 7-9 pH units; or between 8-12 pH units; or between 8-9 pH units; between the anode electrolyte and the cathode electrolyte. In some embodiments, the system is configured to produce a pH difference of at least 4 pH units between the anode electrolyte and the cathode electrolyte.

[219] In some embodiments, the anode electrolyte and the cathode electrolyte in the electrochemical cell, in the methods and systems provided herein, are operated at room temperature or at elevated temperatures, such as, e.g., at more than 40°C, or more than 50°C, or more than 60°C, or more than 70°C, or more than 80°C, or more, or between 30-70°C, or between 70-150°C.

[220] In some embodiments, the systems provided herein result in low to zero voltage systems that generate alkali as compared to chlor-alkali process or chlor-alkali process with ODC or any other process that oxidizes metal ions from lower oxidation state to the higher oxidation state in the anode chamber. In some embodiments, the systems described herein run at voltage of less than 2.5V; or less than 2V; or less than 1.2V; or less than 1.1V; or less than 1V; or less than 0.9V; or less than 0.8V; or less than 0.7V; or less than 0.6V; or less than 0.5V; or less than 0.4V; or less than 0.3V; or less than 0.2V; or less than 0.1V; or at zero volts; or between 0-1.2V; or between 0-1V; or between 0-0.5 V; or between 0.5-1V; or between 0.5-2V; or between 0-0.1 V; or between 0.1-1V; or between 0.1-2V; or between

0.01-0.5V; or between 0.01-1.2V; or between 1-1.2V; or between 0.2-1V; or 0V; or 0.5V; or 0.6V; or 0.7V; or 0.8V; or 0.9V; or 1V.

[221] As used herein, the “voltage” includes a voltage or a bias applied to or drawn from an electrochemical cell that drives a desired reaction between the anode and the cathode in the electrochemical cell. In some embodiments, the desired reaction may be the electron transfer between the anode and the cathode such that an alkaline solution, water, or hydrogen gas is formed in the cathode electrolyte and the metal ion is oxidized at the anode. In some embodiments, the desired reaction may be the electron transfer between the anode and the cathode such that the metal ion in the higher oxidation state is formed in the anode electrolyte from the metal ion in the lower oxidation state. The voltage may be applied to the electrochemical cell by any means for applying the current across the anode and the cathode of the electrochemical cell. Such means are well known in the art and include, without limitation, devices, such as, electrical power source, fuel cell, device powered by sun light, device powered by wind, and combination thereof. The type of electrical power source to provide the current can be any power source known to one skilled in the art. For example, in some embodiments, the voltage may be applied by connecting the anodes and the cathodes of the cell to an external direct current (DC) power source. The power source can be an alternating current (AC) rectified into DC. The DC power source may have an adjustable voltage and current to apply a requisite amount of the voltage to the electrochemical cell.

[222] In some embodiments, the current applied to the electrochemical cell is at least 50 mA/cm²; or at least 100mA/cm²; or at least 150mA/cm²; or at least 200mA/cm²; or at least 500mA/cm²; or at least 1000mA/cm²; or at least 1500mA/cm²; or at least 2000mA/cm²; or at least 2500mA/cm²; or between 100-2500mA/cm²; or between 100-2000mA/cm²; or between 100-1500mA/cm²; or between 100-1000mA/cm²; or between 100-500mA/cm²; or between 200-2500mA/cm²; or between 200-2000mA/cm²; or between 200-1500mA/cm²; or between 200-1000mA/cm²; or between 200-500mA/cm²; or between 500-2500mA/cm²; or between 500-2000mA/cm²; or between 500-1500mA/cm²; or between 1000-2500mA/cm²; or between 1000-2000mA/cm²; or between 1000-1500mA/cm²; or between 1500-2500mA/cm²; or between 1500-2000mA/cm²; or between 2000-2500mA/cm².

[223] In some embodiments, the cell runs at voltage of between 0-3V when the applied current is 100-250 mA/cm² or 100-150 mA/cm² or 100-200 mA/cm² or 100-300 mA/cm² or 100-400 mA/cm² or 100-500 mA/cm² or 150-200 mA/cm² or 200-150 mA/cm² or 200-300 mA/cm² or 200-400 mA/cm² or 200-500 mA/cm² or 150 mA/cm² or 200 mA/cm² or 300 mA/cm² or 400 mA/cm² or 500 mA/cm² or 600 mA/cm². In some embodiments, the cell runs

at between 0-1V. In some embodiments, the cell runs at between 0-1.5V when the applied current is 100-250 mA/cm² or 100-150 mA/cm² or 150-200 mA/cm² or 150 mA/cm² or 200 mA/cm². In some embodiments, the cell runs at between 0-1V at an amperic load of 100-250 mA/cm² or 100-150 mA/cm² or 150-200 mA/cm² or 150 mA/cm² or 200 mA/cm². In some embodiments, the cell runs at 0.5V at a current or an amperic load of 100-250 mA/cm² or 100-150 mA/cm² or 150-200 mA/cm² or 150 mA/cm² or 200 mA/cm².

[224] In some embodiments, the systems and methods provided herein further include a percolator and/or a spacer between the anode and the ion exchange membrane and/or the cathode and the ion exchange membrane. The electrochemical systems containing percolator and/or spacers are described in US Provisional Application No. 61/442,573, filed February 14, 2011 .

[225] The systems provided herein are applicable to or can be used for any of one or more methods described herein. In some embodiments, the systems provided herein further include an oxygen gas supply or delivery system operably connected to the cathode chamber. The oxygen gas delivery system is configured to provide oxygen gas to the gas-diffusion cathode. In some embodiments, the oxygen gas delivery system is configured to deliver gas to the gas-diffusion cathode where reduction of the gas is catalyzed to hydroxide ions. In some embodiments, the oxygen gas and water are reduced to hydroxide ions; un-reacted oxygen gas in the system is recovered; and re-circulated to the cathode. The oxygen gas may be supplied to the cathode using any means for directing the oxygen gas from the external source to the cathode. Such means for directing the oxygen gas from the external source to the cathode or the oxygen gas delivery system are well known in the art and include, but not limited to, pipe, duct, conduit, and the like. In some embodiments, the system or the oxygen gas delivery system includes a duct that directs the oxygen gas from the external source to the cathode. It is to be understood that the oxygen gas may be directed to the cathode from the bottom of the cell, top of the cell or sideways. In some embodiments, the oxygen gas is directed to the back side of the cathode where the oxygen gas is not in direct contact with the catholyte. In some embodiments, the oxygen gas may be directed to the cathode through multiple entry ports. The source of oxygen that provides oxygen gas to the gas-diffusion cathode, in the methods and systems provided herein, includes any source of oxygen known in the art. Such sources include, without limitation, ambient air, commercial grade oxygen gas from cylinders, oxygen gas obtained by fractional distillation of liquefied air, oxygen gas obtained by passing air through a bed of zeolites, oxygen gas obtained from electrolysis of water, oxygen obtained by forcing air through ceramic membranes based on zirconium

dioxides by either high pressure or electric current, chemical oxygen generators, oxygen gas as a liquid in insulated tankers, or combination thereof. In some embodiments, the source of oxygen may also provide carbon dioxide gas. In some embodiments, the oxygen from the source of oxygen gas may be purified before being administered to the cathode chamber. In some embodiments, the oxygen from the source of oxygen gas is used as is in the cathode chamber.

Separation and purification of products and metals

[226] In some embodiments, the methods and systems described herein include separation and purification of the one or more organic compounds or enantiomers thereof (formed during and/or after the reaction of the ethylene or ethane with metal halide in higher oxidation state, as described herein) from the metal halide and the separation and purification of the metal halide before circulating the metal halide solution back in the electrochemical cell. In some embodiments, it may be desirable to remove the organics from the aqueous medium containing metal halide before the metal halide solution is circulated back to the electrochemical cell to prevent the fouling of the membranes in the electrochemical cell. The aqueous medium may be a mixture of both the metal halide in the lower oxidation state and the metal halide in the higher oxidation state, the ratio of the lower and higher oxidation state will vary depending on the aqueous medium from the electrochemical cell (where lower oxidation state is converted to higher oxidation state) and the aqueous medium after reaction with the ethylene or ethane (where higher oxidation state is converted to the lower oxidation state). Various separation and purification methods and systems have been described in US Patent Application No. 14/446,791, filed July 30, 2014 .

Some examples of the separation techniques include without limitation, reactive distillation, adsorbents, liquid-liquid separation, liquid-vapor separation, etc.

[227] In some embodiments of the methods and systems described herein, the average temperature of the electrochemical system (and therefore the temperature of the entering and exiting anode electrolyte with the metal halide) is between 55-105°C, or between 65-100°C, or between 70-95°C, or between 80-95°C, or between 70-85°C, or 70°C, or 80°C, or 85°C, or 90°C. In some embodiments, the average temperature of the reactor (and hence the entering anode electrolyte and ethylene gas to the reactor and exiting aqueous solution from the reactor containing the one or more organic compounds and the metal halide) may be between 120-200°C, or between 135-175°C, or between 140-180°C, or between 140-170°C, or between 140-160°C, or between 150-180°C, or between 150-170°C, or between 150-160°C,

or between 155-165°C, or 140°C, or 150°C, or 160°C, or 170°C, depending on the desired CE or TCA product. The heat gradient between the electrochemical system and the reactor allows for one or more heat exchanges between the streams entering and exiting the electrochemical and reactor systems during the process thereby reducing the overall heat requirement of the process or the system. In addition to the temperature gradient between the electrochemical process and the reactor process, there may be heat released or absorbed during various steps of the processes depending on the thermodynamic requirements of the processes. This may lead to hotter or cooler streams during the process which heat may be exchanged during the process to reduce the overall external heat needed during the process.

[228] In some embodiments, the electrochemical cell system, the reactor, and the separation/purification systems described herein are connected via heat exchange systems in such a way that the overall process is self-sustainable and may not require additional heat source. In some embodiments, the overall heat exchanges of the process is in such a way that not more than 1 ton steam or not more than 0.7 ton steam or not more than 0.5 ton steam is required per ton of the organic product produced. For example, in some embodiments, the overall heat integration of the process is in such a way that not more than 1 ton steam or not more than 0.7 ton steam or not more than 0.5 ton steam is required per ton of the product produced. The streams in the entire process may be integrated in such a way that the streams from one system may heat or cool the streams of the other systems depending on the temperature requirement.

[229] In some embodiments, the entering and exiting streams of processes stated above include, but not limited to, the anode electrolyte, the ethylene or ethane, the aqueous medium comprising the metal halide in the lower and higher oxidation state, steam, water, or combinations thereof. In some embodiments, the one or more heat exchange(s) between the entering and exiting streams of processes includes the heat exchange between the exiting anode electrolyte from the electrochemical process and the exiting aqueous medium from the reactor comprising the one or more organic compounds or enantiomers thereof and the metal halide. In some embodiments of the aforementioned embodiments, the integration of the one or more heat exchange(s) between the entering and exiting streams of processes, reduces the external heat requirement to less than 1 ton of steam per ton of the organic compound/product produced. For example, in some embodiments of the aforementioned embodiments, the integration of the one or more heat exchange(s) between the entering and exiting streams of processes, reduces the external heat requirement to less than 1 ton of steam per ton of the product produced. Various examples of the one or more heat exchange(s) between the

entering and exiting streams of processes are described herein below. In some embodiments of the foregoing methods, the method further comprises recirculating the aqueous medium comprising metal halide in the lower oxidation state and the metal halide in the higher oxidation state back to the anode electrolyte.

[230] The heat exchange system can be any unit configured to exchange heat between the streams. The heat exchange unit may be a double walled hollow tube, pipe or a tank to let the two streams pass each other counter-currently inside the tube separated by a wall so that the heat exchange may take place. In some embodiments, the tube may comprise one or more smaller tubes such that the streams flow counter currently through several hollow tubes inside one main tube. The material of the tube or the pipe may be corrosion resistant such as made from titanium. In some embodiments, the inner tube is made from titanium and not the outer tube or vice versa depending on the stream passing through the tube. For example only, the stream from the electrochemical system containing the metal ions may need a corrosion resistant material but the tube carrying hot water may not need to be corrosion resistant.

[231] While the exiting hotter stream of the catalysis reactor may be used to heat the relatively cooler stream exiting from the electrochemical system (and in turn cool itself down), both the exiting hot streams from the electrochemical as well as the reactor system can be used to heat the ethylene gas and/or distillation columns or other columns in the separation/purification systems of the invention. Similarly, the ethylene gas may be used to cool the condenser portion of the distillation columns in the system. Example of another hot stream is the sodium hydroxide solution generated in the cathode compartment of the electrochemical system which may be used to heat ethylene gas entering the reactor, heat the solution entering the distillator of the vapor-liquid separation system, heat the fractionation distillation column of the scrubber system, or combinations thereof. In some embodiments, cold water may be needed to cool the stream such as to cool the condenser portion of the distillation column. In some embodiments, steam may be needed to heat the stream but as noted above, no more than 1 ton of steam may be needed per ton of the organic product produced in the system or the process.

[232] The metal separation or the metal separator system may include, but not limited to, precipitation, nanofiltration, kinetic dissolution, or combinations thereof. In some embodiments, the metal ions are separated by precipitation technique. In the methods and systems provided herein, the electrochemical cells are run at lower temperature than the reactors. Therefore, the metal solution exiting the reactor may need to be cooled down before being fed into the electrochemical system. In some embodiments, the cooling of the metal

solution may result in the precipitation of the metal ions. Depending on the solubility differences between the metal ions in the lower oxidation state and the metal ions in the higher oxidation state, the metal ions in the two different oxidations states may be separated. For example only, in the Cu(I)/Cu(II) solution system, the reactor may operate at $\sim 150^{\circ}\text{C}$ while the electrochemical system may operate at much lower temperature, e.g. $\sim 70^{\circ}\text{C}$. Therefore, the copper solution needs to be cooled before feeding into the electrochemical cell. It was observed that the cooling of the copper solution resulted in the precipitation of the Cu(II) salt as compared to the Cu(I) salt. The Cu(I) salt solution thus obtained may be fed into the electrochemical cell. The solid containing the Cu(II) may be used to supplement the metal solution exiting the electrochemical cell and entering the reactor.

[233] In some embodiments, the metal ions are separated by nanofiltration. Nanofiltration (NF) is a membrane filtration process which uses diffusion through a membrane, under pressure differentials that may be considerable less than those for reverse osmosis. NF membranes may have a slightly charged surface, with a negative charge at neutral pH. This surface charge may play a role in the transportation mechanism and separation properties of the membrane. For example only, Sterlitech CF042 membrane cell is a lab scale cross flow filtration unit. In this unit, a single piece of rectangular NF membrane is installed in the base of the cell and a polytetrafluoroethylene (PTFE) support membrane is used as a permeate carrier. In a typical operation, a feed stream is pumped from the feed vessel to the feed inlet, which is located on the cell bottom. Flow continues through a manifold into the membrane cavity. Once in the cavity, the solution flows tangentially across the membrane surface. A portion of the solution permeates the membrane and flows through the permeate carrier, which is located on top of the cell. The permeate flows to the center of the cell body top, is collected in a manifold and then flows out of the permeate outlet connection into a collection vessel. The concentrate stream, which contains the material rejected by the membrane, continues sweeping over the membrane then flows out of the concentrate tube back into the feed vessel. Examples of other NF membranes, without limitation include, Dow NF (neutral), Dow NF90 (neutral), Dow NF270 (neutral), TriSep XN45 (neutral), Koch HFM-183 (positively charged), Koch HFP-707 (negatively charged), CEM 2030, FAA130, and FAS130.

[234] In some embodiments, the metal ions are separated by kinetic or transient dissolution technique. In this technique, metal ions that have different kinetics of dissolution can be separated. For example, Cu(II) dissolves faster than Cu(I).

[235] In some embodiments, the reactor and/or separator components in the systems of the invention may include a control station, configured to control the amount of the ethylene or ethane introduced into the reactor, the amount of the anode electrolyte introduced into the reactor, the amount of the aqueous medium containing the organics and the metal ions into the separator, the adsorption time over the adsorbents, the temperature and pressure conditions in the reactor and the separator, the flow rate in and out of the reactor and the separator, the regeneration time for the adsorbent in the separator, the time and the flow rate of the aqueous medium going back to the electrochemical cell, etc.

[236] The control station may include a set of valves or multi-valve systems which are manually, mechanically or digitally controlled, or may employ any other convenient flow regulator protocol. In some instances, the control station may include a computer interface, (where regulation is computer-assisted or is entirely controlled by computer) configured to provide a user with input and output parameters to control the amount and conditions, as described above.

[237] The methods and systems of the invention may also include one or more detectors configured for monitoring the flow of the ethylene gas or the concentration of the metal ion in the aqueous medium or the concentration of the organics in the aqueous medium, etc. Monitoring may include, but is not limited to, collecting data about the pressure, temperature and composition of the aqueous medium and gases. The detectors may be any convenient device configured to monitor, for example, pressure sensors (e.g., electromagnetic pressure sensors, potentiometric pressure sensors, etc.), temperature sensors (resistance temperature detectors, thermocouples, gas thermometers, thermistors, pyrometers, infrared radiation sensors, etc.), volume sensors (e.g., geophysical diffraction tomography, X-ray tomography, hydroacoustic surveyers, etc.), and devices for determining chemical makeup of the aqueous medium or the gas (e.g, IR spectrometer, NMR spectrometer, UV-vis spectrophotometer, high performance liquid chromatographs, inductively coupled plasma emission spectrometers, inductively coupled plasma mass spectrometers, ion chromatographs, X-ray diffractometers, gas chromatographs, gas chromatography-mass spectrometers, flow-injection analysis, scintillation counters, acidimetric titration, and flame emission spectrometers, etc.).

[238] In some embodiments, detectors may also include a computer interface which is configured to provide a user with the collected data about the aqueous medium, metal ions and/or the organics. For example, a detector may determine the concentration of the aqueous medium, metal ions and/or the organics and the computer interface may provide a summary of the changes in the composition within the aqueous medium, metal ions and/or the organics

over time. In some embodiments, the summary may be stored as a computer readable data file or may be printed out as a user readable document.

[239] In some embodiments, the detector may be a monitoring device such that it can collect real-time data (e.g., internal pressure, temperature, etc.) about the aqueous medium, metal ions and/or the organics. In other embodiments, the detector may be one or more detectors configured to determine the parameters of the aqueous medium, metal ions and/or the organics at regular intervals, e.g., determining the composition every 1 minute, every 5 minutes, every 10 minutes, every 30 minutes, every 60 minutes, every 100 minutes, every 200 minutes, every 500 minutes, or some other interval.

[240] The following examples are put forth so as to provide those of ordinary skill in the art with a complete disclosure and description of how to make and use the present invention, and are not intended to limit the scope of what the inventors regard as their invention nor are they intended to represent that the experiments below are all or the only experiments performed. Various modifications of the invention in addition to those described herein will become apparent to those skilled in the art from the foregoing description and accompanying figures. Such modifications fall within the scope of the appended claims. Efforts have been made to ensure accuracy with respect to numbers used (e.g. amounts, temperature, etc.) but some experimental errors and deviations should be accounted for. Unless indicated otherwise, parts are parts by weight, molecular weight is weight average molecular weight, temperature is in degrees Centigrade, and pressure is at or near atmospheric.

[241] In the examples and elsewhere, abbreviations have the following meanings:

AEM	=	anion exchange membrane
ClEtOH	=	chloroethanol
EDC	=	ethylene dichloride
g	=	gram
HCl	=	hydrochloric acid
h or hr	=	hour
l or L	=	liter
M	=	molar
mA	=	milliamps
mA/cm ²	=	milliamps/centimeter square
mg	=	milligram
min	=	minute

mmol	=	millimole
mol	=	mole
μl	=	microliter
μm	=	micrometer
ml	=	milliliter
ml/min	=	milliliter/minute
mV	=	millivolt
mV/s or mVs^{-1}	=	millivolt/second
NaCl	=	sodium chloride
NaOH	=	sodium hydroxide
Pd/C	=	palladium/carbon
psi	=	pounds per square inch
psig	=	pounds per square inch guage
Pt	=	platinum
PtIr	=	platinum iridium
rpm	=	revolutions per minute
STY	=	space time yield
V	=	voltage
w/v	=	weight/volume
w/w	=	weight/weight

EXAMPLES

Example 1

Formation of EDC from ethylene using copper chloride

[242] This experiment is directed to the formation of ethylene dichloride (EDC) from ethylene using cupric chloride. The experiment was conducted in a pressure vessel. The pressure vessel contained an outer jacket containing the catalyst, i.e. cupric chloride solution and an inlet for bubbling ethylene gas in the cupric chloride solution. The concentration of the reactants was, as shown in **Table 1** below. The pressure vessel was heated to 160°C and ethylene gas was passed into the vessel containing 200mL of the solution at 300psi for between 30 min-1hr in the experiments. The vessel was cooled to 4°C before venting and opening. The product formed in the solution was extracted with ethyl acetate and was then

separated using a separatory funnel. The ethyl acetate extract containing the EDC was subjected to gas-chromatography (GC).

[243] In this experiment, the amount of chloroethanol can be increased by increasing the incubation time, total halide concentration, and/or use of noble metals as catalysts.

Table 1

Time (hrs)	CuCl ₂	CuCl	NaCl	HC1 (M)	EDC (mg)	Chloroethanol (mg)	Cu Utilization (EDC)	STY	Mass Selectivity : EDC / (EDC + ClEtOH) %
0.5	6	0.5	1	0.03	3,909.2	395.13	8.77%	0.52	90.82%
					6			6	
0.5	4.5	0.5	2.5	0.03	3,686.0	325.50	11.03%	0.49	91.89%
					0			6	

Example 2

Formation of CE

[244] Ethylene was allowed into 4 mL slit-septa capped vial set in a pressurized reactor. To these vials was added a catalyst composition. To produce CE, a solution consisting of 4.5M CuCl₂, 0.0055M Pd/C, and 1M NaCl was used. The reactor was heated to 135-139°C at 330-340 psig. The production of CE was found to be accelerated with the use of promoters, such as supported noble metal catalyst. **Fig. 7** shows a comparison of two experiments where in the first experiment, no noble metal was used and EDC was found to be the major product. In the second experiment, CuCl was replaced with Pd supported on carbon. The selectivity for CE in this experiment was found to be more than 90% (went from 21% in first experiment to 94% in the second experiment).

Example 3

Formation of CE and TCA

[245] **Experiment 1:** In each of 4 mL capped vials, 150 uL EDC was added at the start. A solution of 5M CuCl₂, 1.5M CuCl, and 2.5M NaCl (**A**); solution of 4M CuCl₂, 1.5M CuCl, and 2.5M NaCl (**B**); solution of 5M CuCl₂, 0.75M CuCl, and 2.5M NaCl (**C**); and solution of 4M CuCl₂, 0.75M CuCl, and 2.5M NaCl (**D**). The vials were held in a heated autogenously pressurized reactor (to prevent capped vials from breaking) at 160°C for 15 and 30 minutes.

Fig. 8 shows that TCA (chloral in Fig. 8) appears to increase exponentially with time and may be a subsequent product of CE. DCA (dichloroacetaldehyde) was not detected after 15 min, but was present at low levels after 30 min at 160°C temperature. The weight based selectivity of EDC went down from 97% after 15 min to 91-93% after 30 min.

[246] Experiment 2: In each of 4 mL capped vials was added a solution of 5M CuCl₂, 1.5M CuCl, and 2.5M NaCl. To each vial was added 10-30 uL of pure chlorinated organics (EDC, CE, MCA, DCA, or TCA). The vials were held in a heated autogenously pressurized reactor (to prevent capped vials from breaking) at 145°C and at 160°C for 8 or 20 minutes. In **Fig. 9**, the conversion of all products upon heating is depicted. The pure compound amounts before heating are included for clarity. Chloroacetaldehyde (CA) and DCA reacted swiftly to TCA (chloral in Fig. 9). CE reacted to form TCA. EDC reacted initially to CE and a small amount of TCA, with time the amount of TCA became more. As observed, the longer residence times (>20 minutes) and higher temperatures (160°C or higher) resulted in TCA. After 30 minutes at 160°C, of what was recovered (97% by mol basis), 50% was EDC, 38% was CE, and 12% was TCA.

Example 4

Formation of dioxane, dioxolane, ether, and chloroform

[247] Solutions were prepared with a concentration of 5.0M CuCl₂, 0.8M CuCl, and 2.6M NaCl.

[248] Experiment 1: In Parr studies, 135mL of this solution was added to the Parr reactor, which was sealed and brought to temperature (160°C) under a nitrogen headspace (195mL) over the course of 30 minutes at a low stir rate (500rpm). Once the temperature and pressure in the Parr reactor had reached equilibrium, the reactor was pressurized with 300psi of ethylene and the stir rate was raised to 1200rpm. The reactor pressure and ethylene feed rate was controlled with a regulator and check valve that were in-line with ethylene flow between the burette and the reactor. The reaction was allowed to progress for 60 minutes before immediately bringing the stir-rate down to 200rpm and then using a cooling loop to rapidly drop the temperature of the reactor. The reactor was cooled to 10°C before it was opened and the organics were extracted with ethyl acetate for GC analysis.

[249] Experiment 2: In High Throughput studies, a stock solution of the aforementioned solution concentration was prepared and 4mL of this solution was pipette into 10mL vials. The vials were capped and the septum was slit so that ethylene was able to penetrate into the vial headspace (5mL headspace per vial). Each vial was placed into the pre-heated High

Throughput unit. The vials were heated to 160°C at 1000rpm, and pressurized in the headspace of the unit (and of the vials inside the unit) with 300psi of ethylene. After 60 minutes, the vials were allowed to cool and the solutions were extracted with ethyl acetate for GC analysis.

[250] Some of the vials used spiked samples that were spiked with very small amounts of chloroethanol. **Figs. 10 and 11** illustrate GC-MS chromatograms for the detection of dioxane, dioxolane, dichloroethylether, and chloroform.

Example 5

Formation of chloroform from TCA

[251] To 100 uL of pyridine was added 200 uL of 0.1 N NaOH solution followed by addition of 100 uL of a mixture of 5 mg/mL TCA hydrate in acetone. This mixture was shaken and allowed to sit for 10 minutes at room temperature. After this time, the solution was a light pink color, indicating the presence of chloroform in pyridine.

What is claimed is:

1. A method, comprising:

contacting an anode with an anode electrolyte wherein the anode electrolyte comprises saltwater and metal halide;

applying a voltage to the anode and cathode and oxidizing the metal halide from a lower oxidation state to a higher oxidation state at the anode;

contacting the cathode with a cathode electrolyte; and

halogenating ethylene or ethane with the anode electrolyte comprising the saltwater and the metal halide in the higher oxidation state, in an aqueous medium wherein the aqueous medium comprises more than 5 wt % water to form one or more organic compounds or enantiomers thereof and the metal halide in the lower oxidation state,

wherein the one or more organic compounds or enantiomers thereof are: substituted or unsubstituted dioxane, substituted or unsubstituted dioxolane, dichloroethylether, dichloromethyl methyl ether, dichloroethyl methyl ether, chloroform, carbon tetrachloride, phosgene, or combinations thereof.

2. The method of claim 1, wherein the saltwater comprises water comprising alkali metal ions or alkaline earth metal ions.

3. The method of claim 1, further comprising forming chloroethanol in more than 20 wt % yield from the halogenation of ethylene or ethane under one or more reaction conditions, wherein the reaction conditions are: temperature of halogenation mixture between about 120-160° C.; incubation time of between about 10 min – about 2 hours; total halide concentration in the halogenation mixture between about 7M – about 12M, catalysis with noble metal, or combinations thereof, and

using the chloroethanol to form the one or more organic compounds or enantiomers thereof defined by: substituted or unsubstituted dioxane, substituted or unsubstituted dioxolane, dichloroethylether, dichloromethyl methyl ether, dichloroethyl methyl ether, chloroform, carbon tetrachloride, phosgene, or combinations thereof.

4. The method of claim 3, wherein the chloroethanol is formed in more than 40 wt % yield.

5. The method of claim 1, further comprising forming trichloroacetaldehyde (TCA) in more than 20 wt % yield from the halogenation of ethylene or ethane under one or more reaction conditions, wherein the reaction conditions are: temperature of halogenation mixture between about 160°C – about 200°C; incubation time of between about 15 min – about 2 hours; concentration of the metal halide in the higher oxidation state at more than 4.5M, or combinations thereof, and

using the TCA to form the one or more organic compounds or enantiomers thereof defined by: substituted or unsubstituted dioxane, substituted or unsubstituted dioxolane, dichloroethylether, dichloromethyl methyl ether, dichloroethyl methyl ether, chloroform, carbon tetrachloride, phosgene, or combinations thereof.

6. The method of claim 5, wherein TCA is formed in more than 40 wt % yield.

7. The method of claim 1, wherein total amount of chloride content in the anode electrolyte is between 6-15M.

8. The method of claim 1, wherein saltwater comprises sodium chloride and the anode electrolyte comprises metal halide in the higher oxidation state in range of 4-8M, metal halide in the lower oxidation state in range of 0.1-2M and sodium chloride in range of 1-5M.

9. The method of claim 1, further comprising forming an alkali, water, or hydrogen gas at the cathode.

10. The method of claim 1, wherein the cathode electrolyte comprises water and the cathode is an oxygen depolarized cathode that reduces oxygen and water to hydroxide ions; the cathode electrolyte comprises water and the cathode is a hydrogen gas producing cathode that reduces water to hydrogen gas and hydroxide ions; the cathode electrolyte comprises hydrochloric acid and the cathode is a hydrogen gas producing cathode that reduces hydrochloric acid to hydrogen gas; or the cathode electrolyte comprises hydrochloric acid and the cathode is an oxygen depolarized cathode that reacts hydrochloric acid and oxygen gas to form water.

11. The method of claim 1, wherein metal ion in the metal halide is iron, chromium, copper, tin, silver, cobalt, uranium, lead, mercury, vanadium, bismuth, titanium, ruthenium, osmium, europium, zinc, cadmium, gold, nickel, palladium, platinum, rhodium, iridium, manganese, technetium, rhenium, molybdenum, tungsten, niobium, tantalum, zirconium, hafnium, or a combination thereof.
12. The method of claim 1, wherein metal ion in the metal halide is iron, chromium, copper, or tin.
13. The method of claim 1, wherein the metal halide is copper chloride.
14. The method of claim 1, wherein the lower oxidation state of metal ion in the metal halide is 1+, 2+, 3+, 4+, or 5+.
15. The method of claim 1, wherein the higher oxidation state of metal ion in the metal halide is 2+, 3+, 4+, 5+, or 6+.
16. The method of claim 1, wherein metal ion in the metal halide is copper that is converted from Cu^+ to Cu^{2+} , metal ion in the metal halide is iron that is converted from Fe^{2+} to Fe^{3+} , metal ion in the metal halide is tin that is converted from Sn^{2+} to Sn^{4+} , metal ion in the metal halide is chromium that is converted from Cr^{2+} to Cr^{3+} , metal ion in the metal halide is platinum that is converted from Pt^{2+} to Pt^{4+} , or combination thereof.
17. The method of claim 1, wherein no gas is used or formed at the anode.
18. The method of claim 1, further comprising adding a ligand to the anode electrolyte wherein the ligand interacts with the metal halide.
19. The method of claim 1, wherein the anode electrolyte comprising the metal halide in the higher oxidation state further comprises the metal halide in the lower oxidation state.

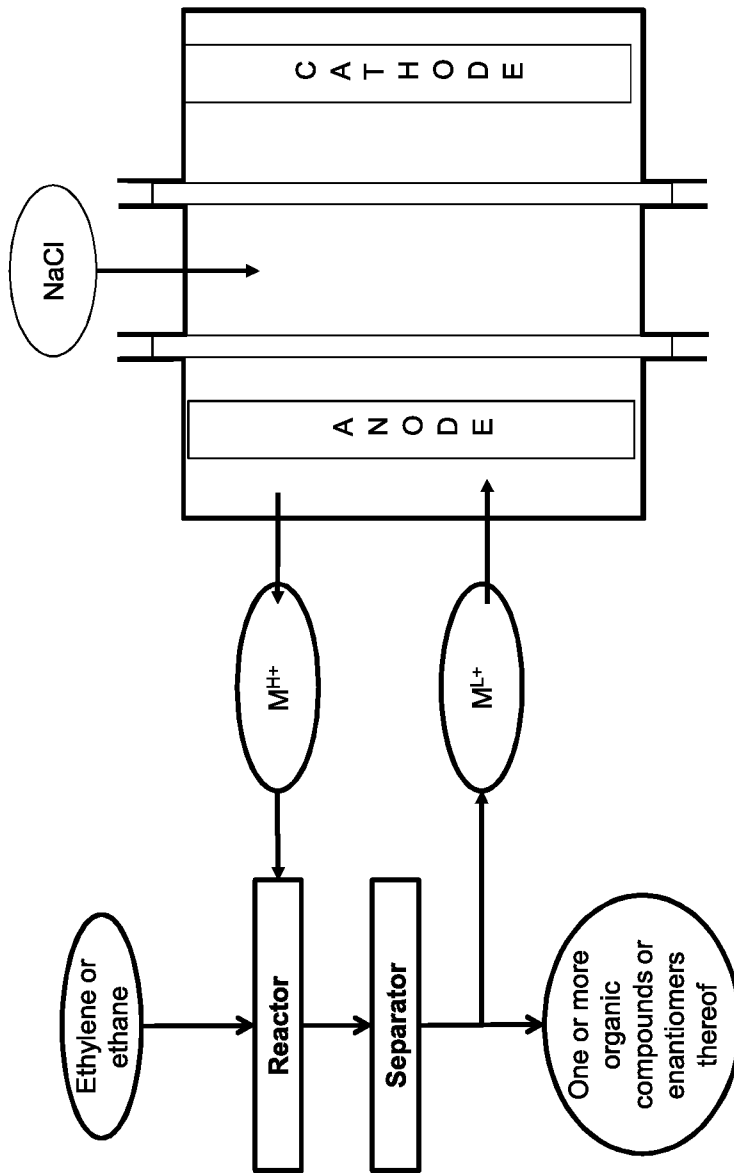

FIGURE 1

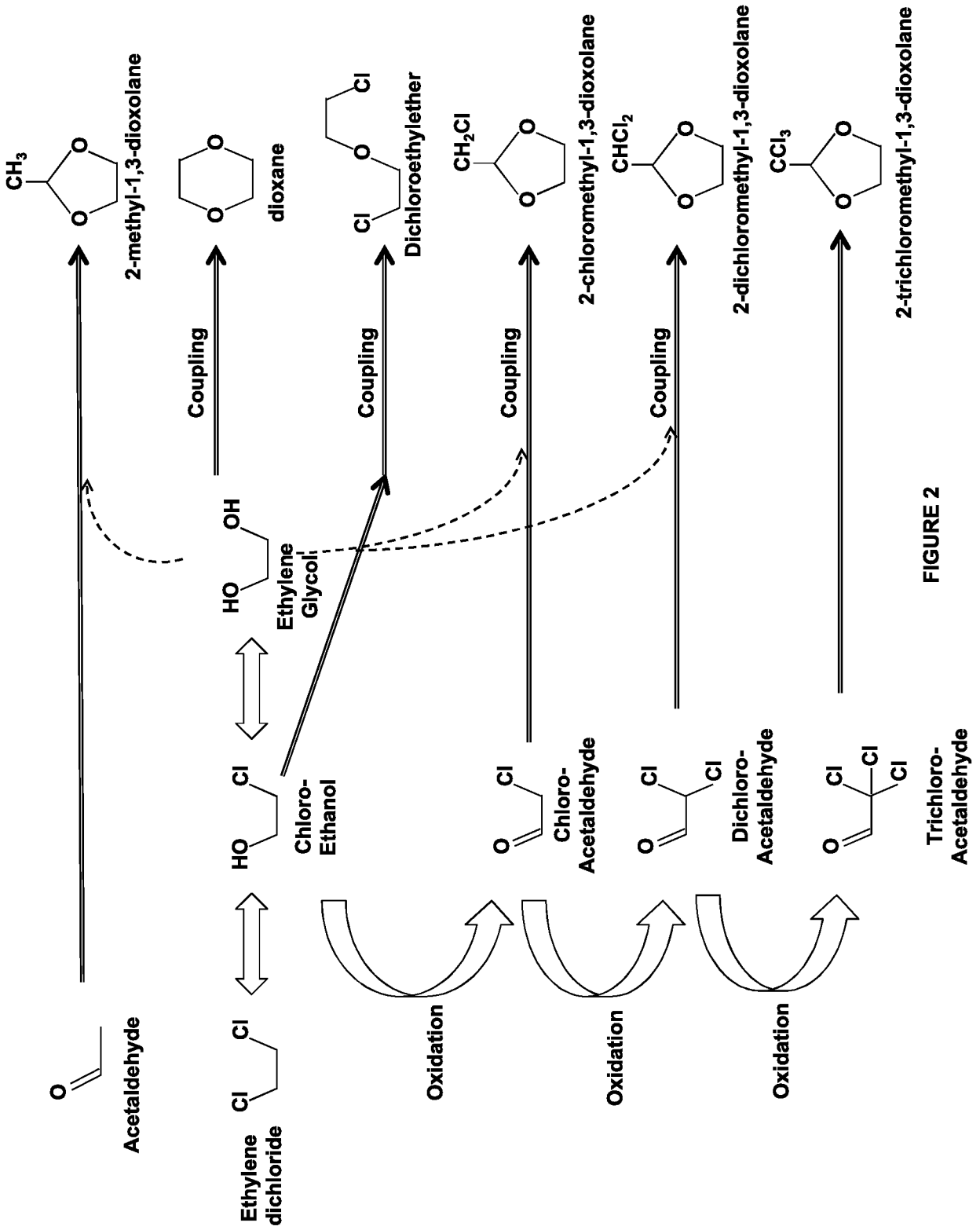

FIGURE 2

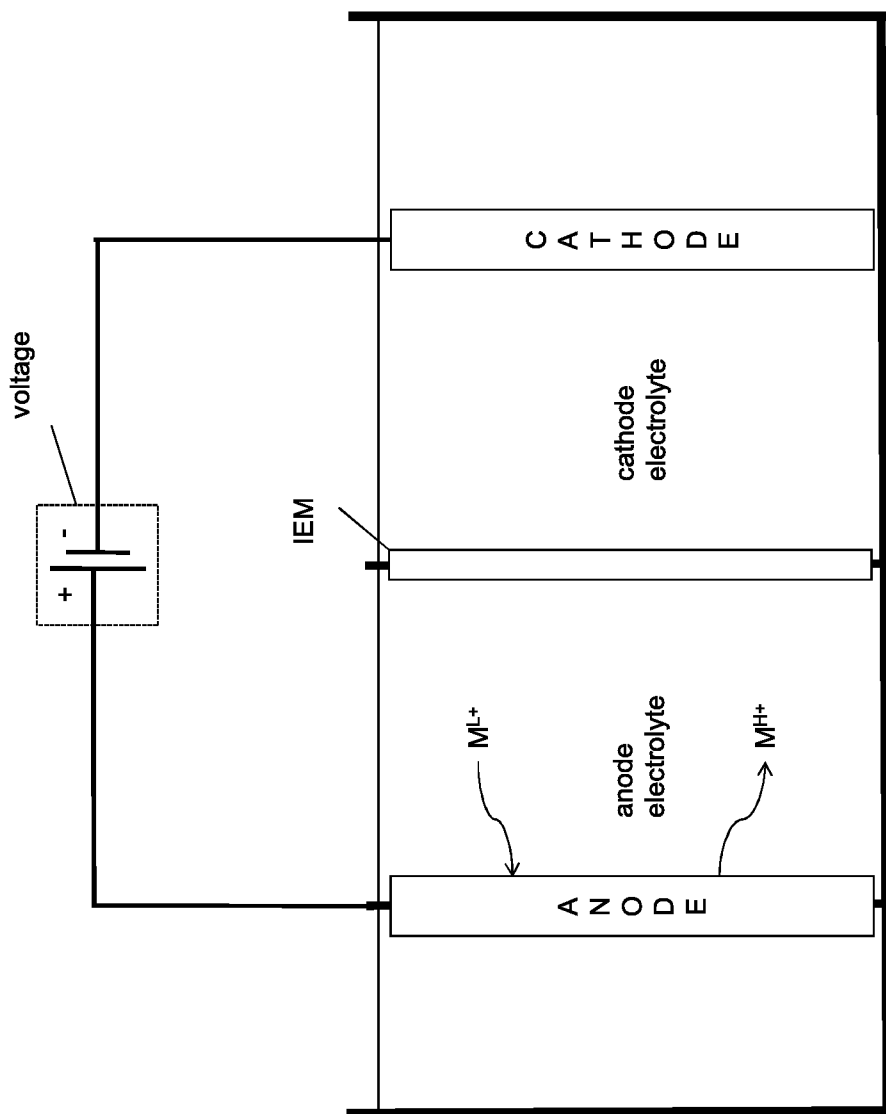

FIGURE 3

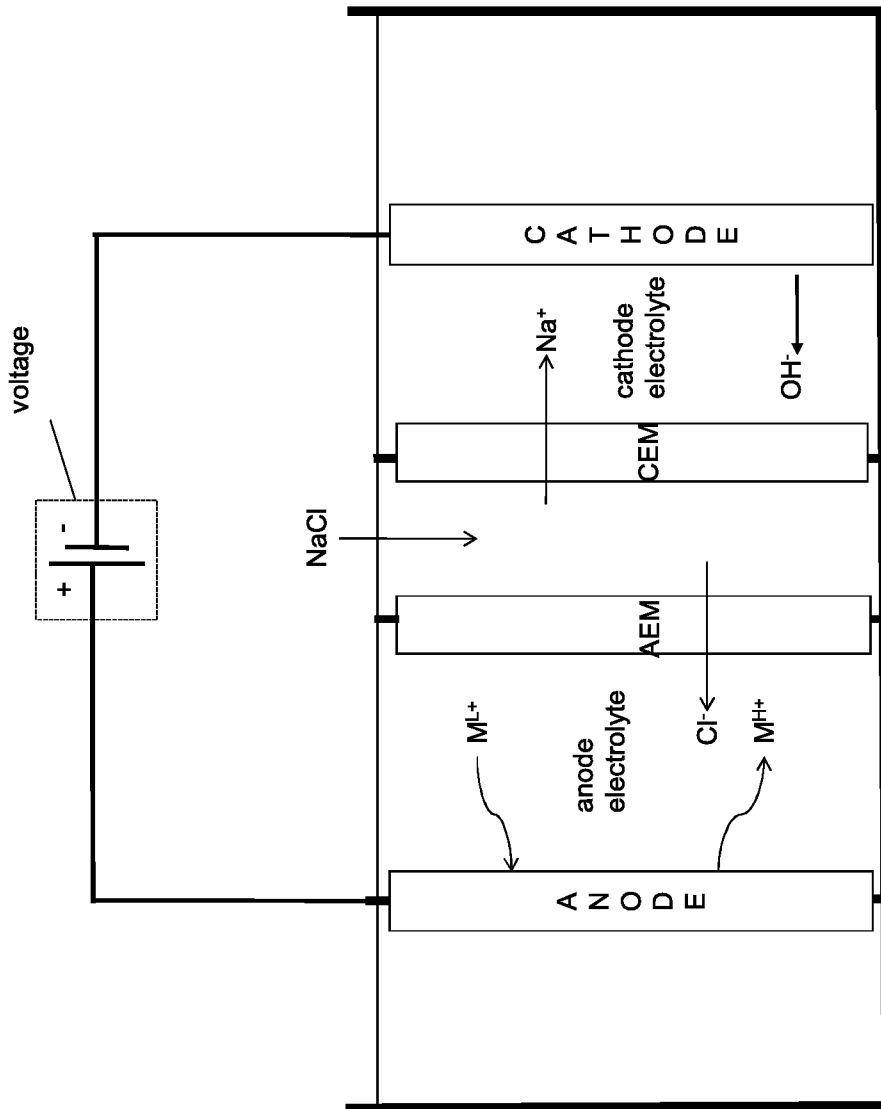

FIGURE 4

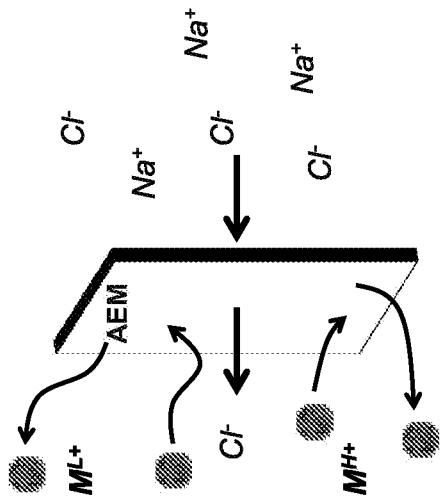

FIGURE 5A

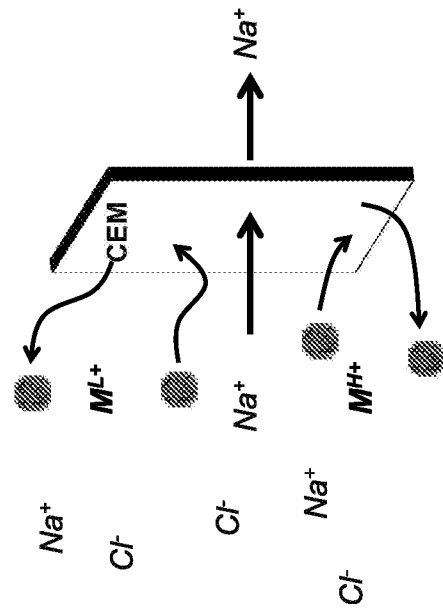

FIGURE 5B

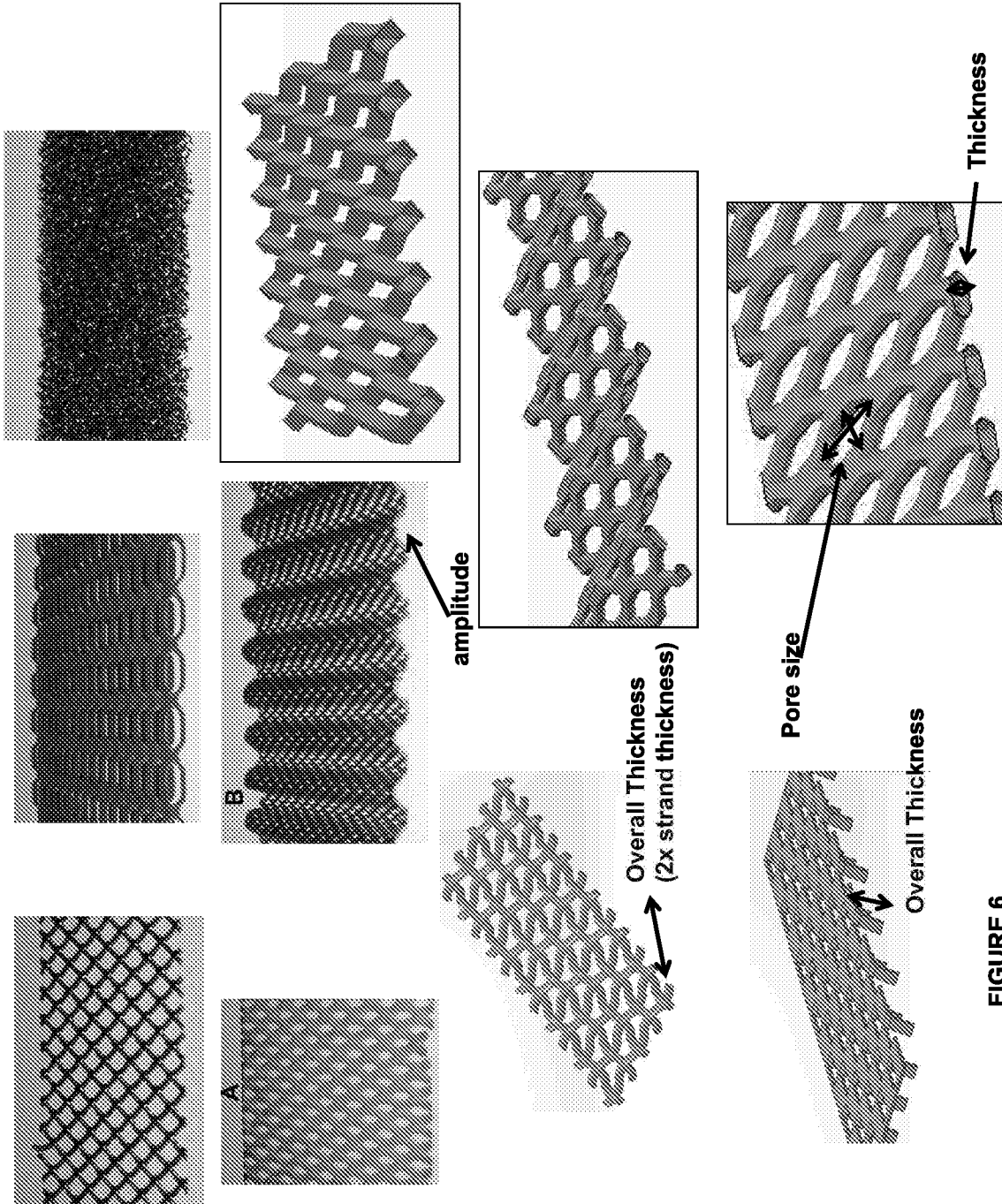

FIGURE 6

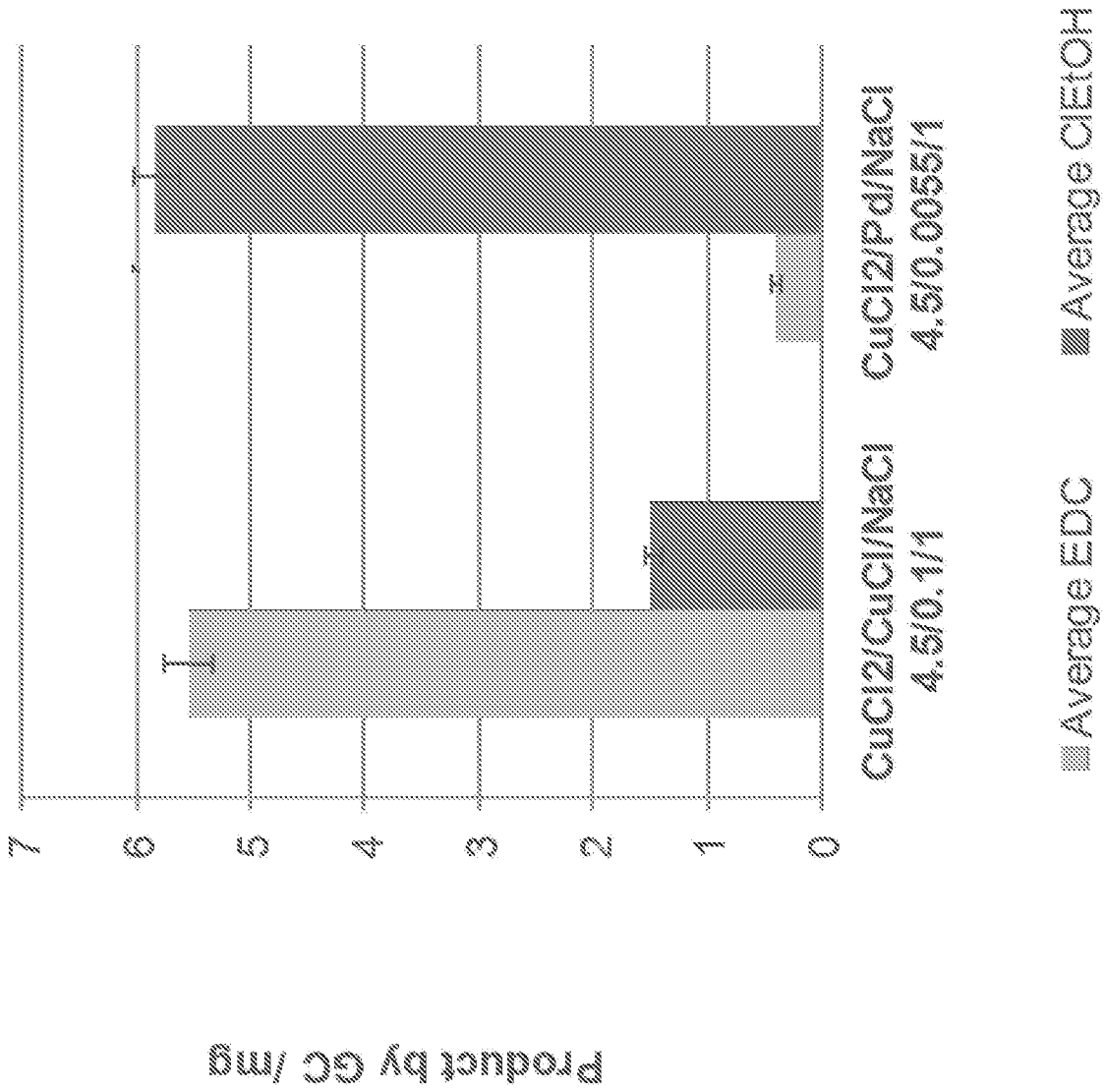

FIGURE 7

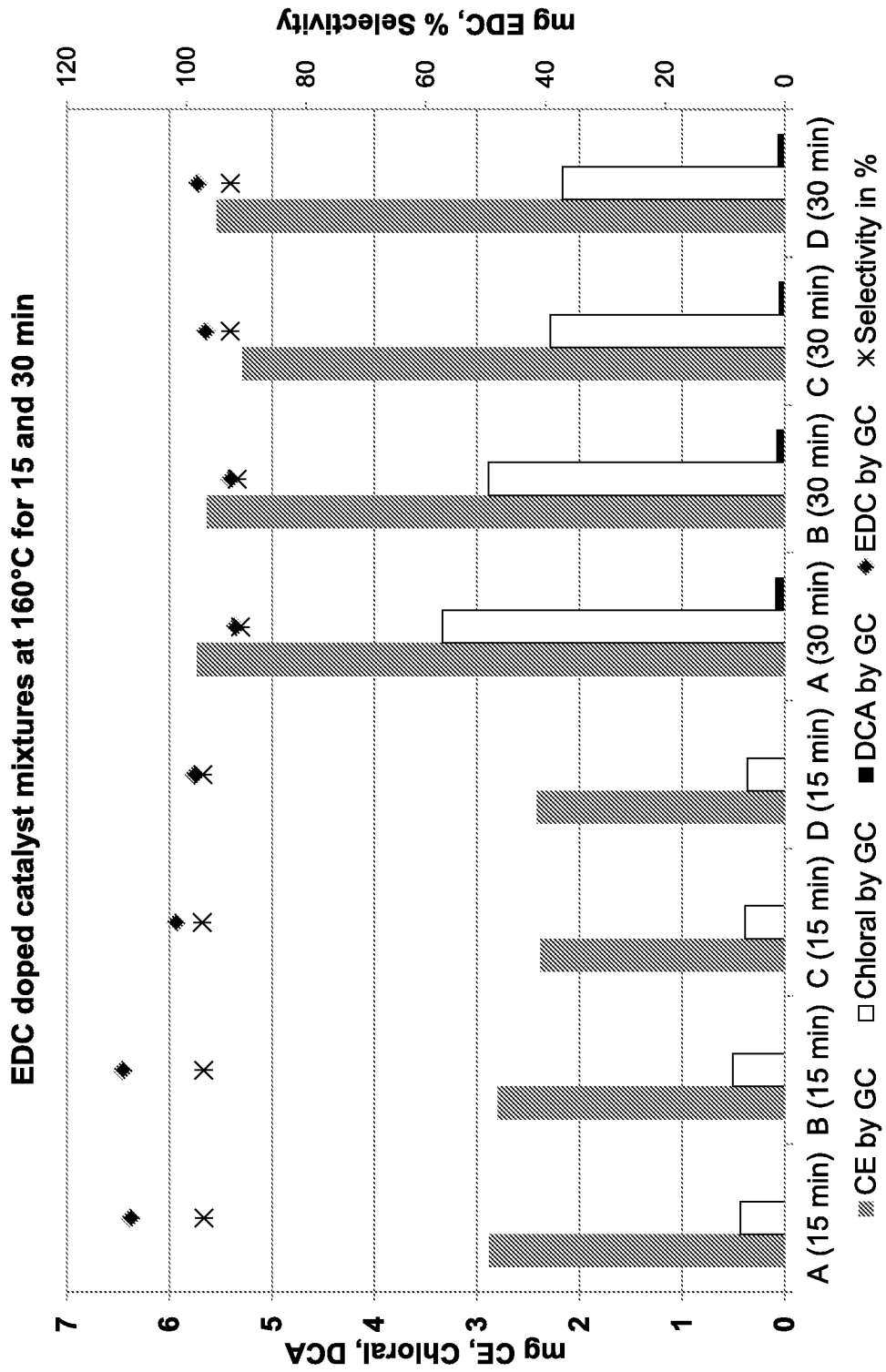

FIGURE 8

Doped catalyst mixtures before and after heating for specific time

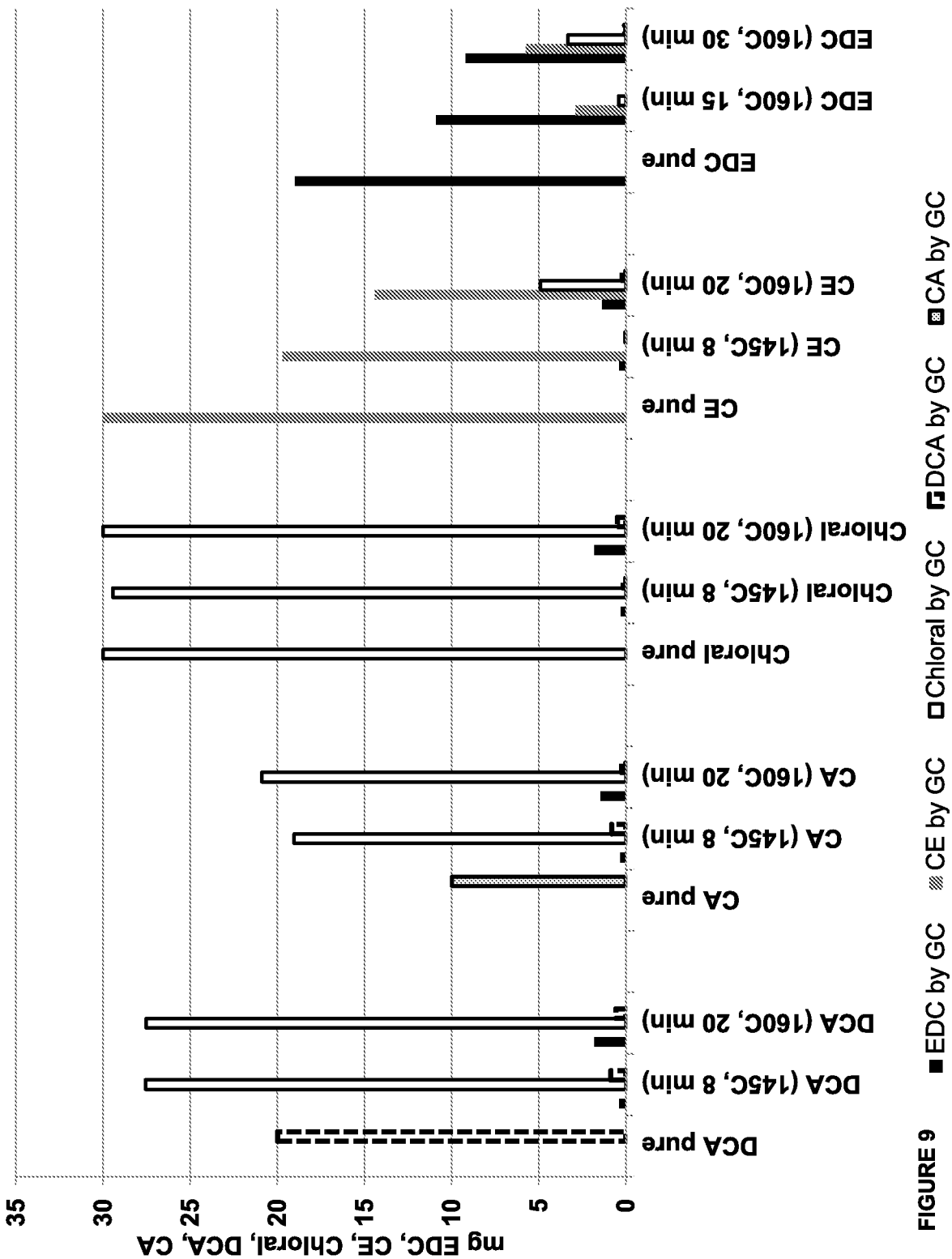

FIGURE 9

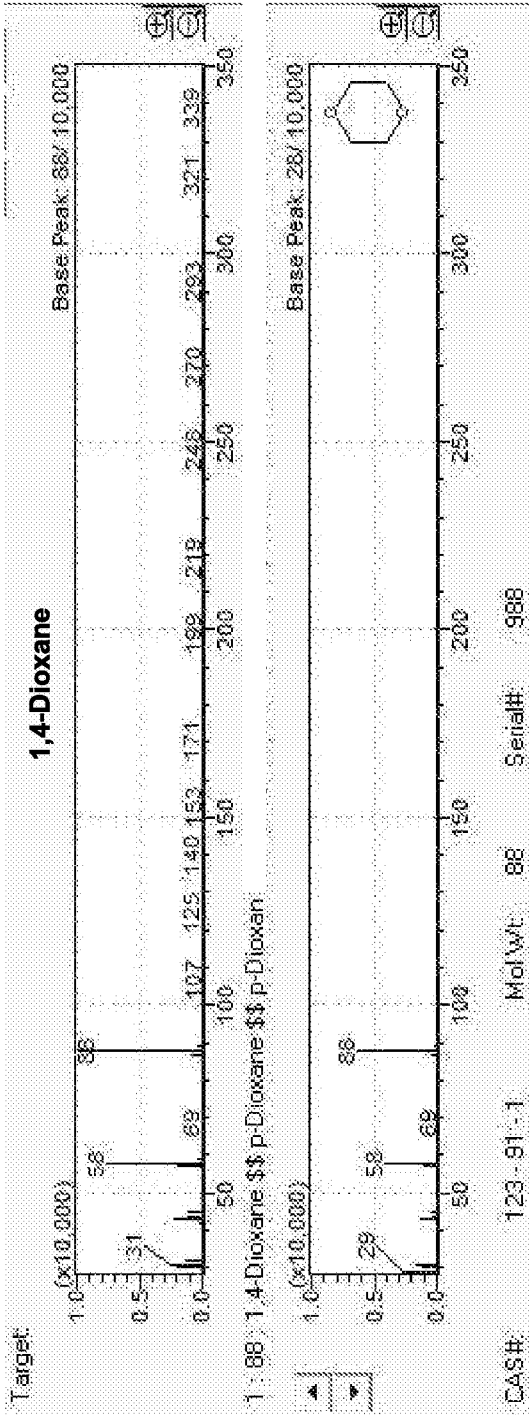

FIGURE 10

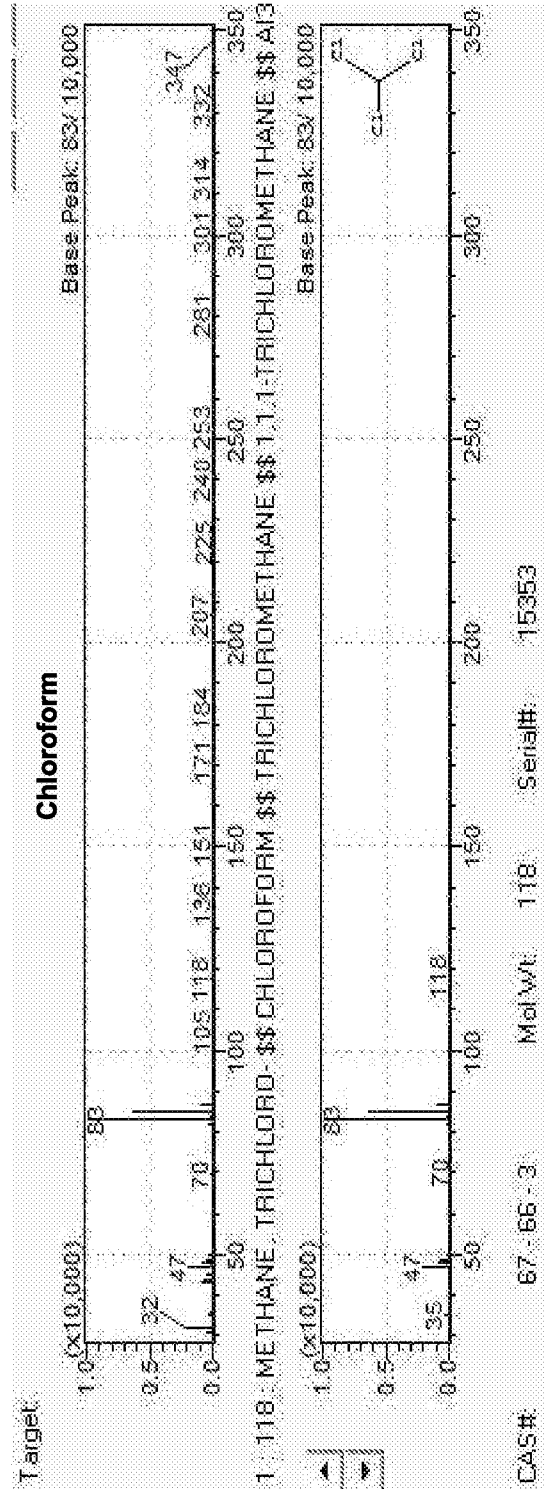
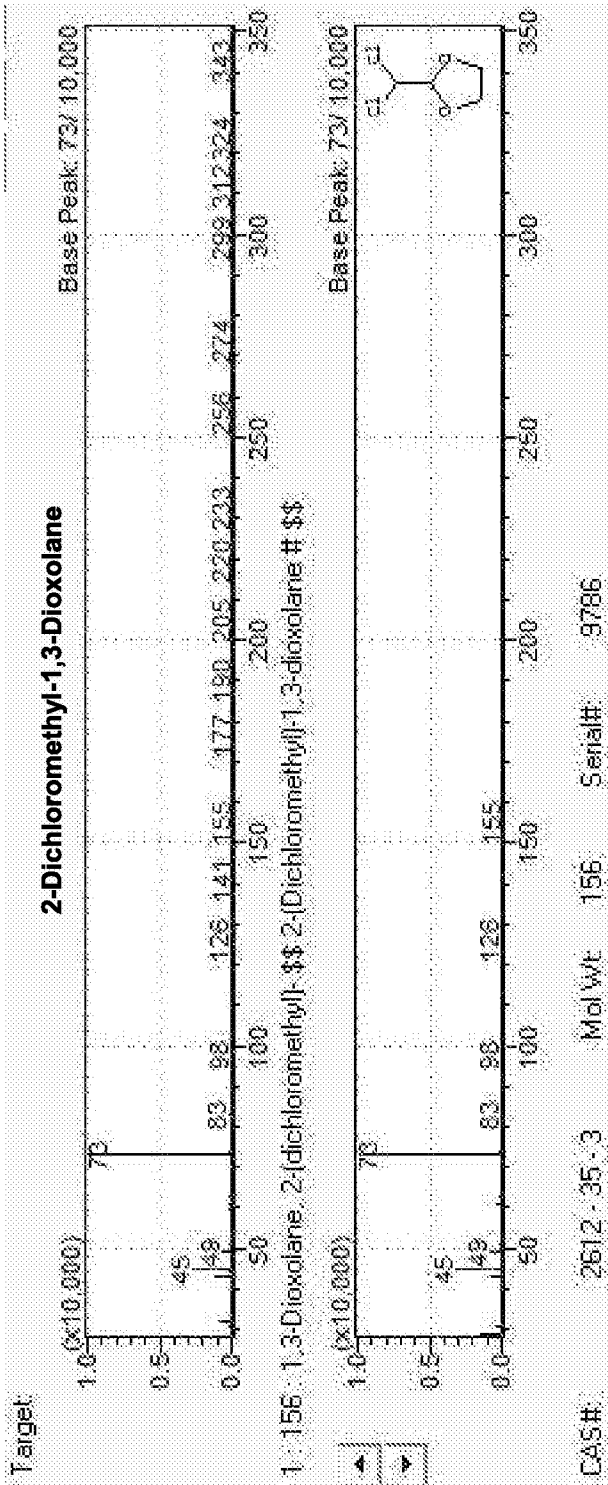

FIGURE 11

