

(19)



(11)

**EP 1 914 501 A1**

(12)

**EUROPEAN PATENT APPLICATION**

(43) Date of publication:  
**23.04.2008 Bulletin 2008/17**

(51) Int Cl.:  
**F41A 9/02** (2006.01) **F41A 9/72** (2006.01)  
**F41A 17/56** (2006.01)

(21) Application number: **06122647.8**

(22) Date of filing: **20.10.2006**

(84) Designated Contracting States:  
**AT BE BG CH CY CZ DE DK EE ES FI FR GB GR HU IE IS IT LI LT LU LV MC NL PL PT RO SE SI SK TR**  
Designated Extension States:  
**AL BA HR MK RS**

(71) Applicant: **Prosapiens Malmoe AB**  
**211 42 Malmö (SE)**

(72) Inventor: **Mautone, Juan Francisco Minas (UY)**

(74) Representative: **Karlsson, Leif Gunnar Börje Ström & Gulliksson AB**  
**P.O. Box 4188**  
**203 13 Malmö (SE)**

(54) **Semi-automatic weapon**

(57) A new design for semi - automatic weapon for several tubes cartridges loading system for long guns, wherein an in-between connection steel part (11) fixes the barrel (3, 13) to the receiver (10). The retention of the cartridges inside the parallel tubes (45) is done by three metallic nails. The springs of the loading tubes push the cartridges into the cylinder (30) inside the gun through three openings made into the front side of the receiver (10) under the barrel. The rotation mechanism of the cylinder is a result of changing the movement of the bolt (14) from the horizontal into vertical.

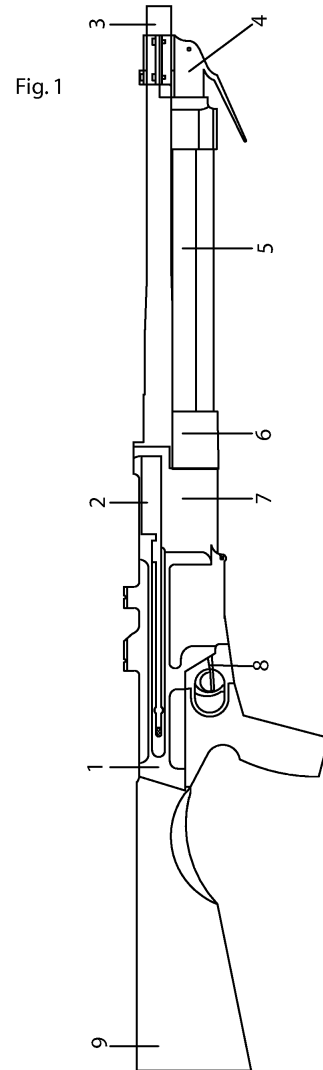

**EP 1 914 501 A1**

## Description

### AREA OF INVENTION

**[0001]** The invention concerns to semi-automatic shot-guns for military or police use.

### BACKGROUND OF INVENTION

**[0002]** The known semi - automatic shotguns have a restricted loading capacity since, without modifying too much the desired size of a modern fighting shotgun, they can carry a maximum of nine or ten cartridges. This is because the cartridges are lodged aligned lengthwise in a tube that the weapon has under the barrel.

**[0003]** If the magazine is extended to increase the loading capacity, the barrel must be extended too. This is undesirable in this type of shotgun. The rest of the solutions to achieve a significant increase in the loading capacity which have been proposed so far, have resulted in increasing some of the dimensions of the weapons, making them uncomfortable and impractical to handle. As a consequence, they are not suitable for military or police use.

**[0004]** Other solutions have been proposed for known shotguns, such as Wagner, Bentley and alike. The applicant considers that said solutions are mere theoretical ones since they result in weakening or eliminating the magazine tube.

**[0005]** The actual function of the magazine tube in standard shotguns is to give resistance to their structure. The rear end of the barrel floats inside the receiver and becomes firm actually because it is attached to the front end of the magazine tube. So, if the magazine tube is weakened or eliminated, the barrel will be assembled without the necessary firmness.

**[0006]** On the other hand, the easier cocking or uncocking of the shotguns in the field is mostly searched by the users. The known shotguns are not so easy to cock or uncock in the field.

### PURPOSE OF THE INVENTION

**[0007]** The present invention is designed to find the solution to the prior art problems.

**[0008]** The applicant tested said system in standard long guns. Two problems arose. Firstly, when the ex works magazine was removed in order to replace it with the cartridges loading system claimed in Uruguayan Record U 3714, the guns were no longer rigid enough to keep the barrel steady and firm. Also, the design of the standard weapons prevented the several barrels from being stable. To couple the cartridges loading system claimed in Uruguayan Record U 3714, it was necessary to modify the way of fixing the barrel to the receiver without the traditional magazine tube.

**[0009]** The second problem upon trying to use said cartridges loading system in standard long guns was,

that it always resulted in a non ergonomic adaptation.

**[0010]** The weapons were heavier and uncomfortable to carry and take from one place to another. Thus, the inventor realized that they were not good solutions. The invention presented in this patent document is a new design of semi - automatic shotgun which incorporates the cartridges loading system described in Uruguayan Record U 3714 and makes it possible to use it properly. Said system solves the two problems by providing the necessary firmness and stability in order to operate the weapon, and by achieving an ergonomic, light, easy to carry design of semi - automatic shotgun for police and military use.

**[0011]** Further, the known weapons are cocked in such a way that its cleaning in the field is much difficult and slow because the user has to disassemble many parts and, further, at many occasions the cleaning is only possible when performed by an expert. In order to solve said problems, this invention proposes a weapon that is mounted from below so modifying the way of its manufacture.

### SUMMARY OF INVENTION

**[0012]** The invention is a new design of semi - automatic shotgun whose main feature is an in - between connection steel part which fixes de barrel to the receiver. This steel part plays three roles. Firstly, it enables the magazine to float. Secondly, the barrel can be firmly attached to the receiver, thus providing stability. Thirdly, it works as a lock between the steel bolt and the barrel, so that it resists the explosion when the gun is fired, providing firmness. The firmness does not rely on an attached tube as in standard shotguns.

**[0013]** The in - between connection steel part is tube shaped. Its front end is screwed to the barrel, whereas its rear end lodges the bolt head, which is locked inside by two small balls which fit into cavities specially cut in the part. Transversely it comprises a perforated rectangular steel plate which is fixed to the end of the receiver by screws.

**[0014]** In order to attach the barrel and the receiver firmly, the barrel is screwed to the steel part, which, in turn, is fixed to the receiver by screws, preferably five of them.

**[0015]** The cartridges loading system is disclosed in Uruguayan Record U 3714. The mechanism which makes said cartridges loading system work consists in a receiver that contains the bolt, a detachable trigger assembly and a four - canal cylinder connected to a cylinder hand, placed at the end of a two - axle pivot. The detachable trigger assembly contains the shots system, a two - axle pivot lever, an operating driving arm thereof, a fixed lever. The trigger assembly is detachable as one unit. The cylinder is made of plastic with four longitudinal canals symmetrically cut in their outer surface, which have a semicircular section. The cylinder rotates automatically by means of the two - axle pivot lever when the gun is

fired. The rotation mechanism of the cylinder is a result of changing the movement of the bolt from horizontal into vertical, when the pivot balances firstly on a front axle, and secondly on a rear axle. The bolt pushes the two - axle pivot lever by means of the operating driving arm contained into the trigger, the fixed lever located at the end of the two - axle pivot lever enables the rotation of the cylinder. The cylinder turns 90° clockwise every time the gun is shot.

**[0016]** The bolt slides inside a tube that goes through the receiver longitudinally, together with its inner pieces, inertial mass, nut, small balls and firing pin.

**[0017]** In an advantageous assembly model, the magazine consists of parallel tubes of said cartridges loading system that surround the barrel, encircling its sides and lower part.

**[0018]** Their ends are fastened by fitting ends that keep them firmly attached. The magazine is fixed to the gun between the front side of the receiver and a lock with a handle fitted in the barrel near the front end. The retention of the cartridges inside the tubes is done by means of three metallic nails, which emerge each from one tube and retain them by the shell head. The nails hold the shell head of the last cartridge, preventing the springs from dislodging them while the magazine is out of the shotgun. As soon as the magazine is placed and the lock with a handle is actuated, the retaining metal nails hide and release the cartridges.

**[0019]** The springs push and enable a cartridge from each tube to enter each canal of the cylinder through openings made into the front side of the receiver under the barrel.

**[0020]** As it is disclosed in Uruguayan Record 3714, the bolt which is aligned with the chamber, goes through the upper canal of the cylinder. It remains empty while the others have one cartridge each. When the operating handle is operated, the bolt pushes the driving arm, the double axle pivot balances and raises the hand which makes the cylinder rotate one fourth turn clockwise. Then, the cartridge in the left canal moves to the upper position, facing the chamber. At the same time, the empty upper canal turns right facing the right loading tube and receiving a cartridge therefore.

**[0021]** When the operating handle is released, the bolt is sent forwards by its recoil spring, and pushes the cartridge which is waiting inside the chamber. Once the gun is shot, the fired shell triggers the semi-automatic mechanism, similarly to that of an ordinary long firearm.

**[0022]** The bolt moves backwards and operates the pivot, which lifts the fixed lever. Said fixed lever makes the cylinder rotate another fourth turn and the cycle starts again. When all the cartridges in the right tube are discharged, the upper canal is not loaded and remains empty until the gun is fired again. Then, the empty canal aligns with the lower tube and receives a cartridge there from. Once the lower tube is empty, it is fed by the cartridges from the left tube. When it is discharged, the magazine is empty and can be replaced by a full one. To eject the

empty magazine, the user pushes downwards with the same hand that holds it. As a result the empty magazine falls out of the gun and the user may replace it with a full magazine.

5 **[0023]** The primary field uncocking is made easier by means of unscrewing the trigger stock and removing the trigger assembly downwards, afterwards the bolt assembly may be released backwards by means of rotating the butt. Thus, the trigger assembly or box is detachable as  
10 one unit.

## BRIEF DESCRIPTION OF THE DRAWINGS

15 **[0024]** In the following, the invention will be explained with reference to the accompanying drawings, where:

Fig. 1 shows the semi - automatic weapon according to the present invention;

Fig. 2 shows a cross sectional view of the semi - automatic weapon of Fig.1;

20 Fig. 3 shows a cross sectional view of the semi - automatic weapon of Fig.1 showing the details of the two-axle pivot lever and the operating driving arm thereof;

25 Fig. 4A shows a rear view of the cylinder according to the present invention;

Fig. 4B shows a longitudinal sectional view of the cylinder according to the present invention;

30 Fig. 4C shows a rear view of the bored plate according to the present invention;

Fig. 5A shows a view of the magazine according to the present invention;

Fig. 5B shows a cross sectional view of the magazine according to Fig. 5A;

35 Fig. 6 shows a longitudinal sectional view of the fixing device according to the present invention;

Fig. 7 shows a longitudinal sectional view of the firing mechanism according to the present invention showing the sure device at its off (A) and on positions (B);

40 Fig. 8A shows a sectional view of the butt according to the present invention;

Fig. 8B shows a cross sectional view of the weapon according to the present invention showing the butt;

45 Fig. 9 shows the magazine; and

Fig. 10 shows a detailed projected view of the cylinder, plate, and magazine assembly.

## DETAILED DESCRIPTION OF EMBODIMENTS

50 **[0025]** The following is a possible way of manufacturing the utility model hereby described.

**[0026]** FIG. 1: It is an overall description of the weapon where the parts are numbered 1 to 9. Said parts are described in the subsequent drawings with different numbering.  
55

1 the receiver

2 the bolt assembly

- 3 the barrel
- 4 the front lock of the magazine
- 5 the magazine
- 6 the bored plate between the magazine and the cylinder
- 7 the case of the cylinder
- 8 the trigger
- 9 the butt

**[0027]** FIG. 2: a receiver 10 is fixed to the barrel 3 by the in-between connection steel part 11, which is screwed 12 to the receiver 10. The tube 17 goes through the receiver lengthwise. The bolt 14 runs through the tube together with its inner parts: inertial mass 15, nut 16, the small balls 18 and the firing pin 19. Behind this bolt assembly 14 and aligned to it, are the spring 20, the follower 21 and the running top 20.1.

**[0028]** FIG. 3 illustrates how the cylinder rotates automatically when the gun is fired. After the shot, the bolt 14 moves backwards pushed by the shell. A groove 14.1 is in the bolt 14 and it moves backwards as well. On its way, it pushes the operating driving arm 23 and its wheel 23.1 slides on the edge of the two - axle pivot lever 24, forcing it to pivot on axle 25 first and axle 26 afterwards. The operating driving arm 23 rotates on the axle 23.3. The hand 27, which is joined to the two - axle pivot lever 24 through the axle 28, goes up and pushes the small nuts 29, which comprise the cylinder star 30 and they make the cylinder rotate 90°. At the end of its way downwards, the two - axle pivot lever 24 pushes the cylinder stop 31 and sends it to one of the cavities the cylinder 30 has for that purpose. As the bolt 14 moves forwards again, the operating driving arm 23 returns to its original position by means of the spring 32. As a consequence, the cylinder stop 31 is sent back to its initial position by its spring 33 and disengages the cylinder 30. The bolt 14 occupies the upper canal of the cylinder 30 and secures its position.

**[0029]** In FIG. 4A, we have a rear view of the cylinder 30 and the small nuts 35 which are part of the steel star 34. We can see the holes where the cylinder stop 31 fits and the central hole where the axle 36 that keeps the cylinder 30 positioned fits. Inside said hole there is a tube 37 which centers the cylinder 30 on the axle 36 and acts as a tighten separator while the cylinder is fit into the gun.

**[0030]** In FIG. 4B, there is a longitudinal sectional view of the cylinder 30. It shows how the axle 36 is fixed to the receiver 10 by means of a threaded end 36.1. The other end forms an "allen" nut with a cylindrical crown end 36.2. This axle 36 is firmly attached to the plate 40, which is embedded in the receiver 10. The separator 37 prevents the axle 36 from tightening the cylinder. The separator 37 has a cone shaped end to allow the bushing 39 of the cylinder 30 to slide with minimum friction.

**[0031]** In FIG. 4C, we have a rear view of the bored plate 40 with the round openings 40.1 through which the cartridges in the tubes 45 move from the magazine 41 to the cylinder 30.

**[0032]** The magazine 41 comprised three identical

tubes 45 located as seen in the diagram in FIG 5A. They are a joint assembly by virtue of the fitting end 41.1 at the rear end, and fitting end 41.2 at the front end. The three tubes are open in their rear ends and closed in their front ends. There is a spiral spring 41.3 and a follower 41.4 in each one of them. The rod 42 that is part of the magazine assembly goes through the central axis of both fitting ends 41.1 and 41.2. At the front end 42.2 is the spring 44 which keeps the rod tensed forwards. When the tubes 45 are loaded, the cartridges are retained by the shell head of the last one by virtue of the nails 43 as shown in FIG. 5B.

**[0033]** When operating the gun (see Fig. 6) a full magazine must be placed after removing the empty one, so that the rear side of the tubes 45 align with the openings 40.1, and the front side fits in the device 46 fixed near the front end of the barrel 13. The fixing device 46 comprises a main part 46.1 fastened to the barrel by the screws, and comprises a bolt 46.2 connected to a lever with cam 46.3 by means of the spring 46.4. When the lever 46.3 turns towards the barrel 13, the bolt 46.2 is pushed through the axle of the fitting 41.2 and pushes the rod 42 towards the receiver 10. The rear end 42.1 of the rod projects backwards and engages the cylindrical crown 36.2. As a result, the magazine 41 is firmly fixed to the gun. In addition, as the rod 42 moves backwards, it pulls the three nails 43 forcing them to hide under the wall of the three tubes 45 and releasing the cartridges, which are pushed by the followers 41.4 and the springs 41.3. Three cartridges, one from each tube, enter the corresponding canals 30.1 of the cylinder 30 through the windows 40.1.

**[0034]** In FIG. 7, we can see a longitudinal section of the firing mechanism 50 with the sure device off (Position A) and on (Position B); with the box 51, the trigger 52, the transferring bar 53, the hammer 54, the sear 55, the main spring 56, the sear spring 55.1, the axle 57 of the box 51, the axle 54.1 of the hammer 54, and the axle 55.2 of the sear 55. The system is assembled as follows: as the bolt 14 moves backwards, it pulls the point 54.2 of the hammer 54, and makes it turn around its axle 54.1 until - with the groove 54.3 - it mounts the sear 55. The spring 55.1 of the sear 55 keeps it in cocking position. The main spring 56 remains tense and pushes the bar 54.4. When the trigger 52 is pulled, the transferring bar 53 recoils and pulls the sear 55 tail 55.3. It disengages from the groove 54.3 of the hammer 54, and the gun is fired. The disengagement of the sear 55, which is necessary for the gun to be cocked again while the shooter pulls the trigger, occurs when the hammer 54 is mounted. This is because the transferring bar 53 is pressed down by the projection 53.1 of the hammer 54, thus pulling it down and releasing it from the tail 55.3. The spring 59 pull the trigger and its transferring bar back to position. The box 51 is detachable when disassembling the gun. In FIG. 7. the sure device, locking or safety mechanism is also shown. A safety lever 70 is eccentrically pivotable around an axle 70.1 in a first end. In the position A the

safety mechanism disengaged. By pivoting the lever 70 with its free end 70.2 downwards, the first end presses down the transferring bar 53, which is disengaged from the tail 55.3. As the lever is pushed down, the first end is also getting contact with sear 55 and locking the sear 55 and the hammer 54 from being moved. Further, the free end 70.2 of the lever 70 is now located in the space where a finger is inserted to pull the trigger 52. Thus, the safety mechanism comprise not only the locking mechanism that prevent the sear 55 and the hammer 54 from being moved, but also a physical obstacle preventing a finger to reach the trigger 52. The firing mechanism or trigger assembly 50 is detachable as one unit when disassembling the gun.

**[0035]** FIG. 8A shows a section of the butt 60 with the tube 61. Its front end is screwed, and its rear end is fixed to the butt plate 61.2. It also shows the lock 62 with holes 61.3 and its spring 63 and cup 65, which lodges the lock assembly 62. The butt 60 can be disconnected without using tools so that it occupies little room when carried, and in order to remove the bolt assembly 14 (also denoted as 2) as well. The tube 61 is firmly attached to the butt plate 61.2. The butt plate is kept into position by the lock 62 which enters the hole and prevents it from rotating. The butt 60 is retained because it is tightened between the receiver 10 and the butt plate 61.2. The butt plate is kept into position by the lock 62, which enters the hole and prevents it from rotating. The butt 60 is retained because it is tightened between the receiver 10 and the butt plate 61.2. In order to remove the butt 60, it is necessary to press down the lock 62 and turn the butt plate 61.2 until the tube 61 is completely unscrewed from the screwed lodging 61.1. Once the butt 60 and the tube 61 have been removed, the recoil spring 20, together with the follower 21 can be removed from the rear side of the receiver 10. As a result, the bolt assembly 14 is released.

**[0036]** In FIG. 8B, the box 51 can be folded downwards around the axle 57 without using any tools, in order to check or do outdoor cleaning. It is only necessary to turn the wheel 59.2 of the rod 59, which is screwed 59.1 to the receiver 10.

**[0037]** In FIG. 9 the magazine 41 is shown having three tubes 45. The magazine 41 also includes a fitting end 41.1 at the rear end of the magazine 41, and a fitting end 41.2 at the front end of the magazine 41. Between the fitting end 41.1 and the fitting end 41.2, and through the fittings the tubes 45 extend.

**[0038]** In FIG. 10 a detailed projected view of the cylinder 30, plate 40, and magazine assembly 41 is shown.

**[0039]** The utility model herein claimed, as well as its parts, can be manufactured and reproduced according to the usual methods known to gun manufacturers.

**[0040]** The invention is not limited to the embodiments described above and shown on the drawings, but can be supplemented and modified in any manner within the scope of the invention as defined by the enclosed claims.

## Claims

1. A semi automatic weapon for several tubes cartridges loading system for long guns comprising:

5  
10  
15  
20  
25  
30  
35  
40  
45  
50  
55

- a barrel (3, 13);
- a receiver (10) having a front end and a rear end, wherein the barrel (3, 13) is firmly connected to the front end of the receiver (10) by an in-between connection steel part (11);
- a butt (9) connected to the rear end of the receiver;
- a magazine (5, 41) located underneath of the barrel (3, 13) and in front of the receiver (10), the magazine (5, 41) having at least one tube (17, 37, 45, 61);
- a trigger (8, 52); and
- a cylinder (30) contained inside the receiver (10) and a bored plate (6) located between the magazine (5, 41) and the cylinder (30);
- wherein the cylinder (30) turns 90° every time the weapon is shot.

2. A semi automatic weapon for several tubes cartridges loading system for long guns according to claim 1 further comprising:

30  
35  
40  
45  
50  
55

- a receiver (10) having a front and a rear end,
- a barrel (3, 13) connected to the front end of the receiver (10);
- an in between connection steel part (11) to fix the barrel (3, 13) to the receiver (10), wherein the in between connection steel part (11) includes a threaded front end (36.1) and rear end (36.2),
- wherein the front end of the in between connection steel part (11) is screwed to the barrel (3, 13),
- wherein the rear end of the in between connection steel part (11) lodges a bolt head to firmly fix the in between connection steel part (11) to the receiver (10),
- a butt (9) connected to the rear end of the receiver;
- a magazine (5, 41) located underneath of the barrel (3, 13) and in front of the receiver (10); the magazine (5, 41) having at least one tube;
- a cylinder (30) located between the magazine (5, 41) and the receiver;
- and a bored plate (6) located between the cylinder (30) and the magazine (5, 41), wherein the bored plate includes one opening per each tube of the magazine in order to move cartridges from the magazine to the cylinder;
- a trigger (8, 52).

3. A semi automatic weapon according to claim 1, wherein the in-between connection steel part (11)

has a tubular shape.

4. A semi automatic weapon according to claim 1, wherein the receiver (10) further contains a bolt or bolt assembly (14), and a trigger assembly. 5
5. A semi automatic weapon according to claims 1 and 4, wherein the trigger assembly is detachable and contains the two-axle pivot lever (24), the operating driving arm (23) thereof, and a trigger set. 10
6. A semi automatic weapon according to claim 1, wherein the cylinder (30) has an outer surface, wherein the outer surface includes four longitudinal canals (30.1) having semicircular sections. 15
7. A semi automatic weapon according to claim 4, wherein the bolt (14) further slides inside a longitudinal tube that extend lengthwise through the receiver (10). 20
8. A semi automatic weapon according to claim 1, wherein the magazine (5, 41) comprises three identical tubes (45). 25
9. A semi automatic weapon according to claim 8, wherein each tube (45) includes an open end and a closed end, wherein each tube further comprises a spring, a follower and a rod that goes through the central axis both ends. 30
10. A semi automatic weapon according to claims 2 and 8, wherein the bored plate (6) contained inside the receiver (10) includes one opening per each tube of the magazine (5, 41) to move cartridges from the magazine to the cylinder (30). 35

40

45

50

55

Fig. 1

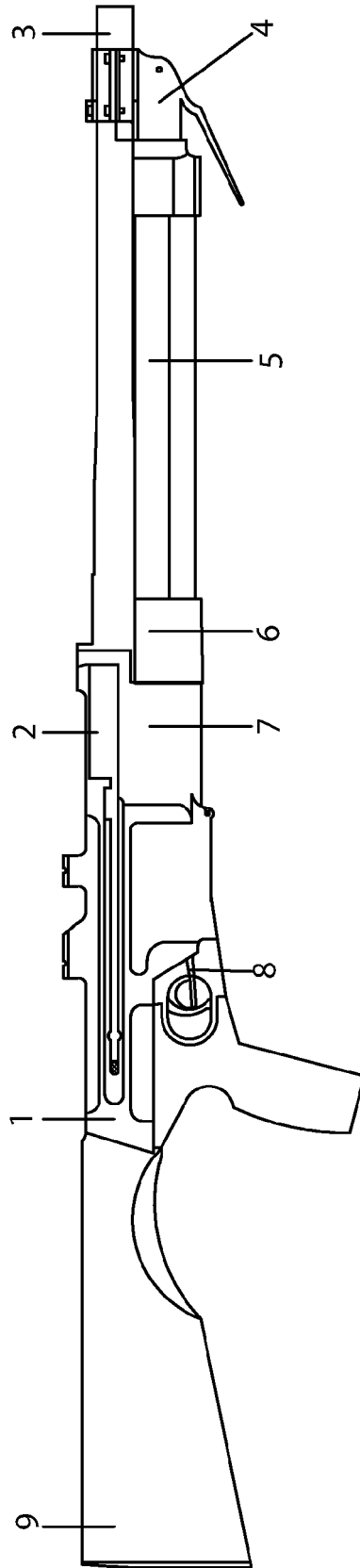

Fig.2

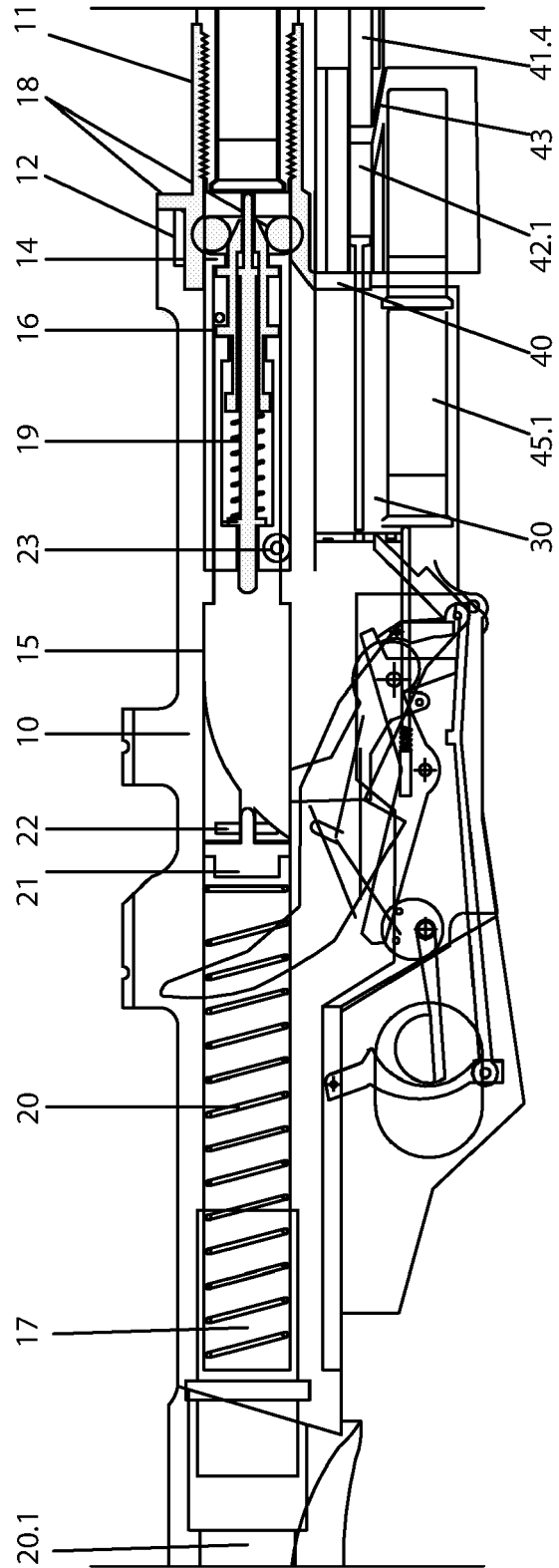

Fig.3

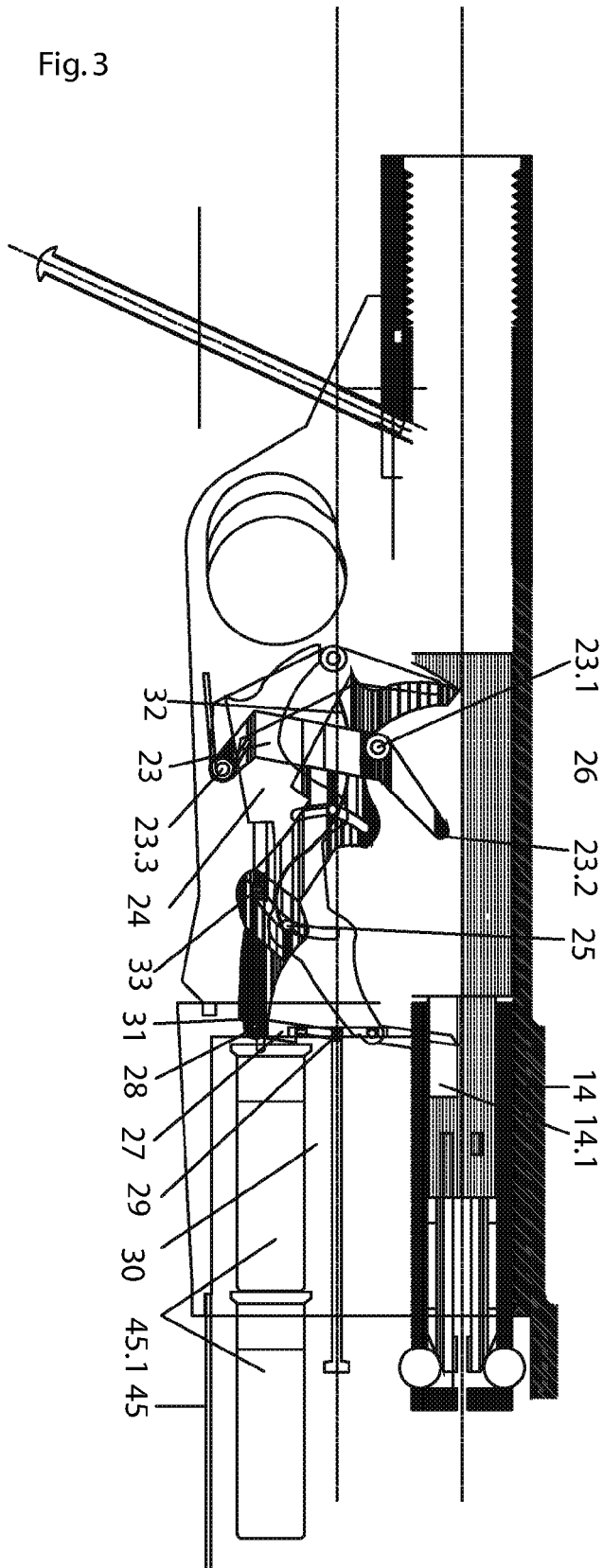

Fig.4A

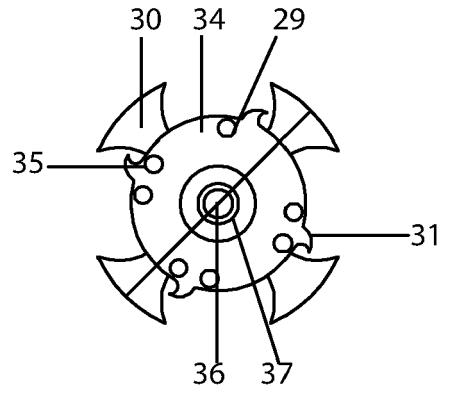

Fig.4C

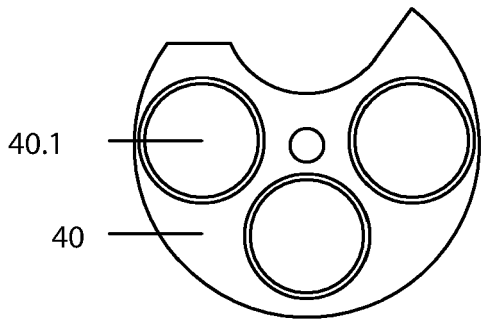

Fig.4B

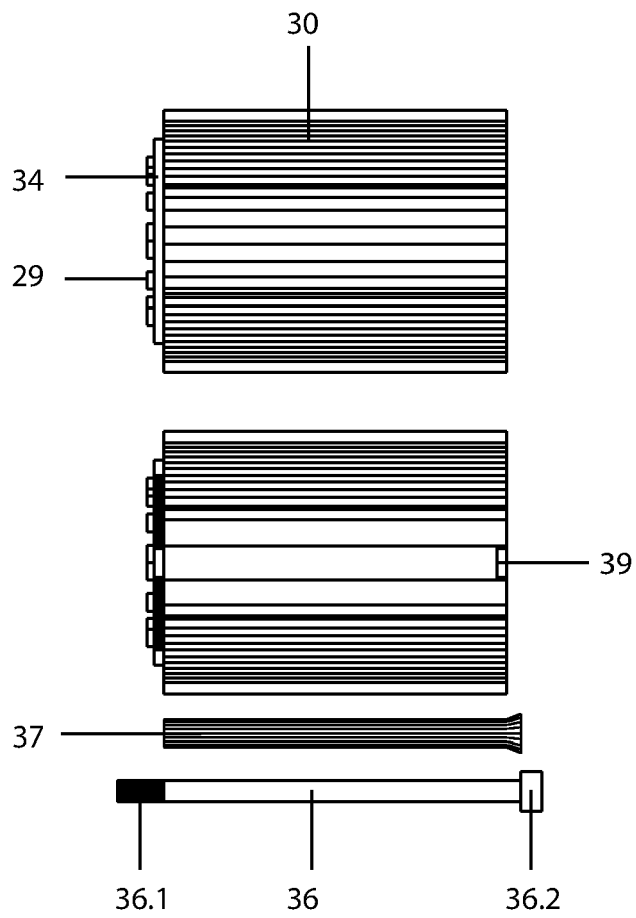

Fig. 5A

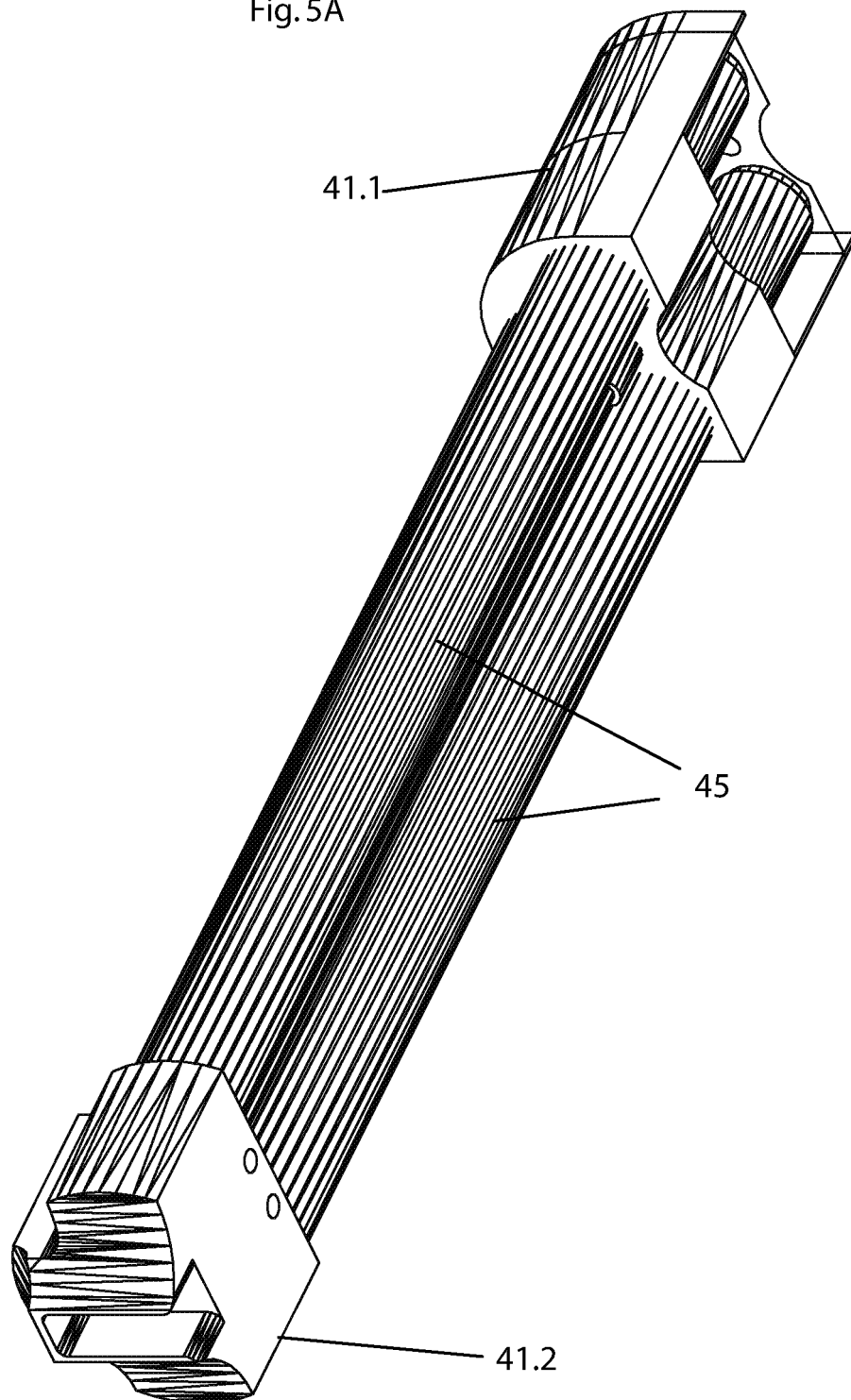

Fig. 5B

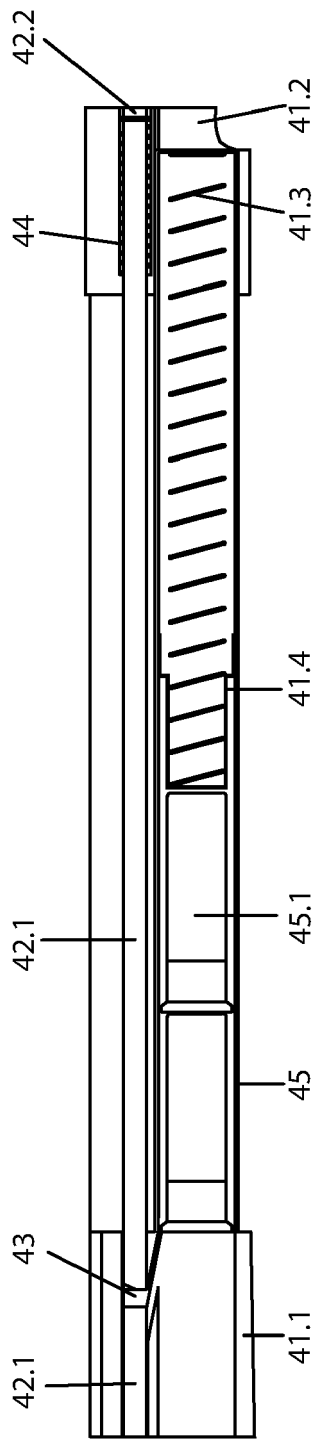

Fig.6

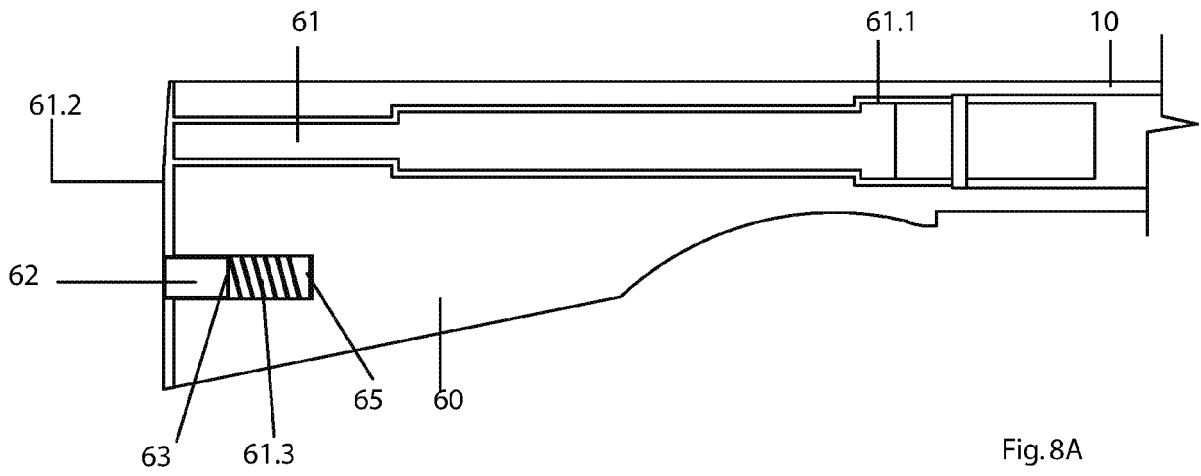
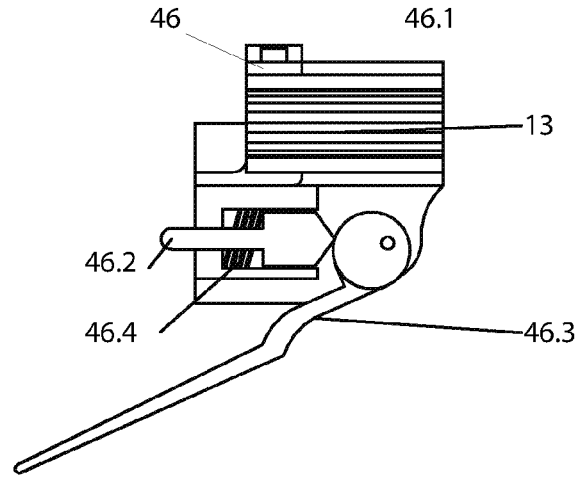

Fig.8A

Fig.7

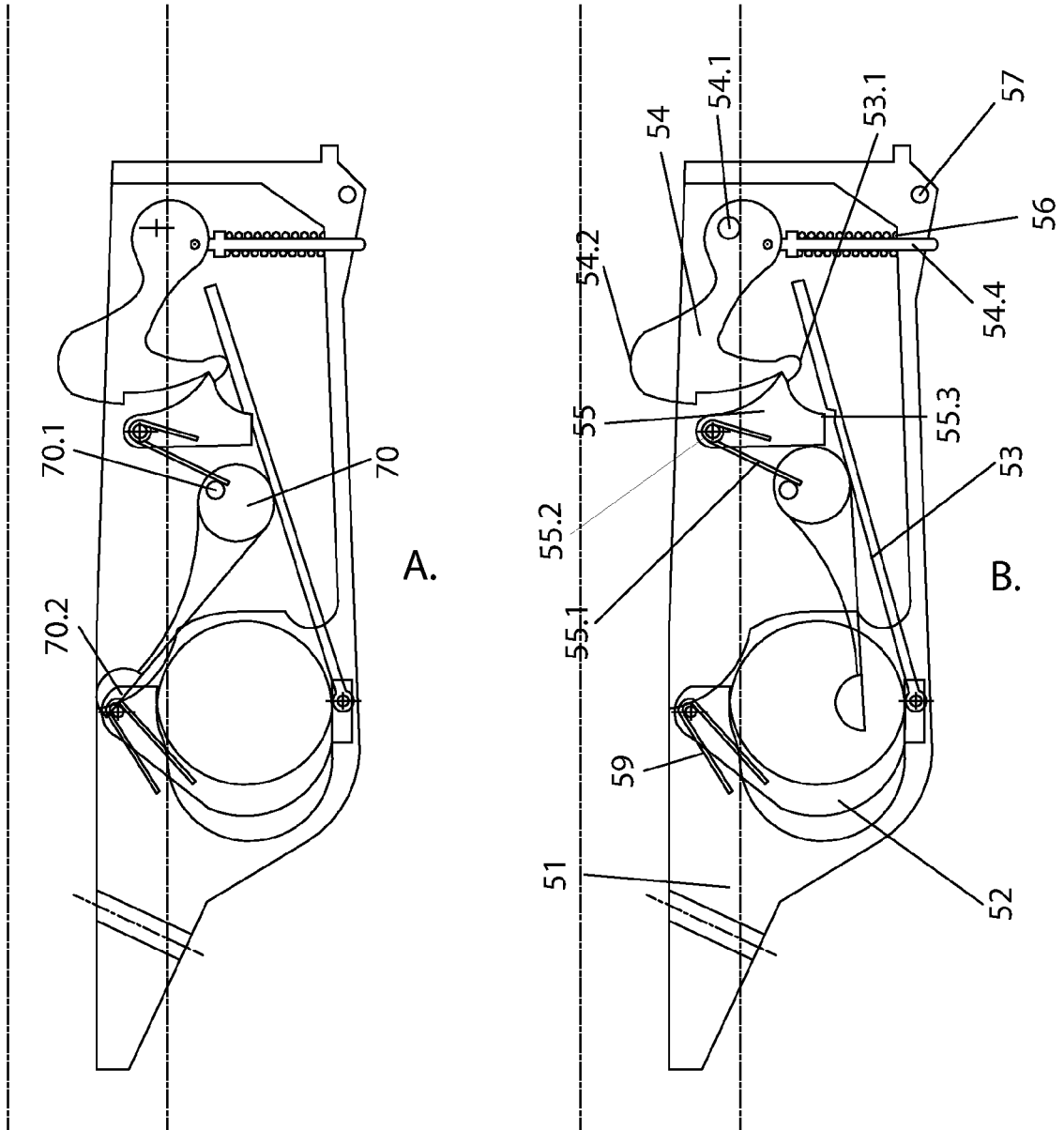

Fig. 8B

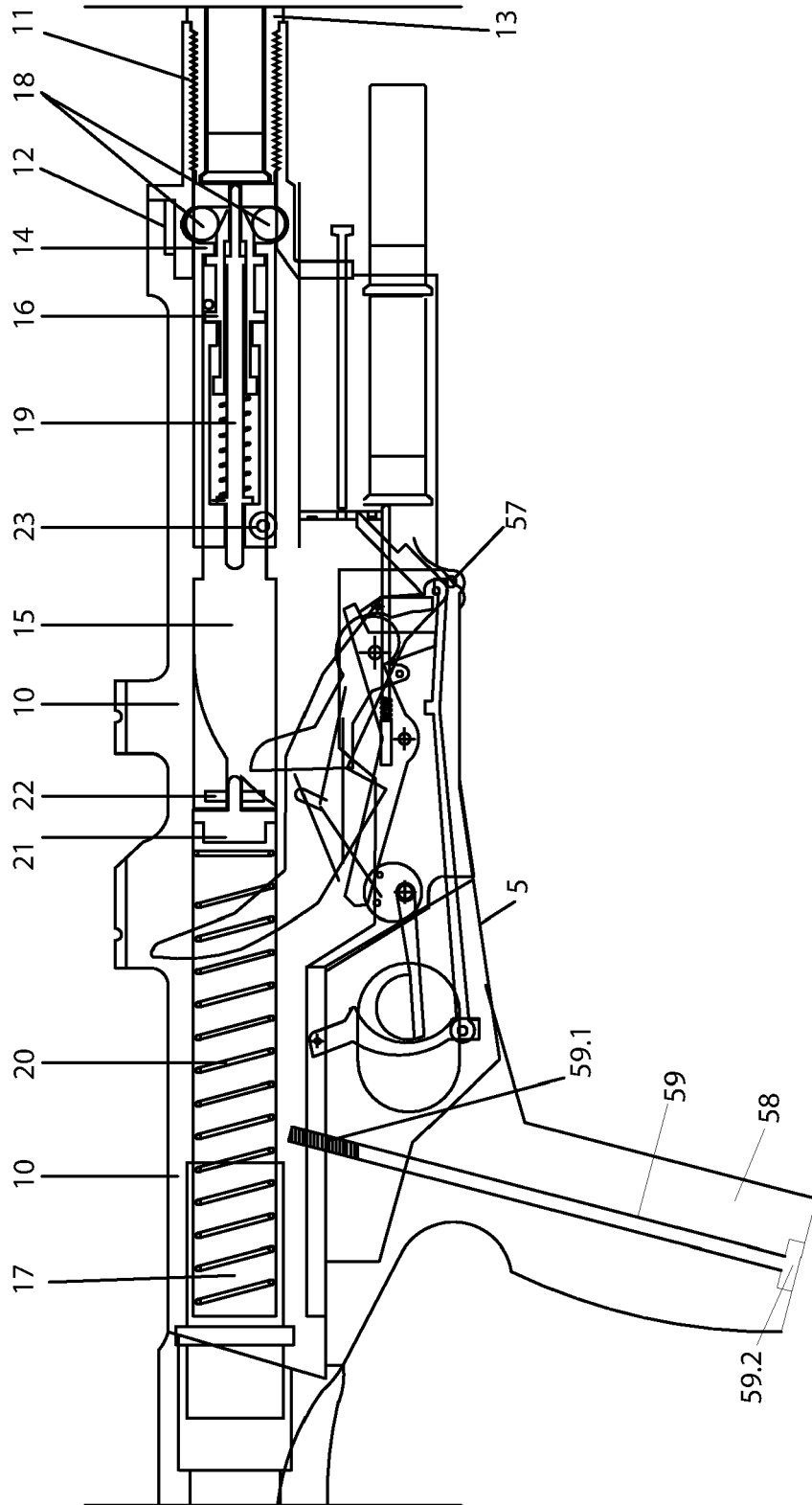
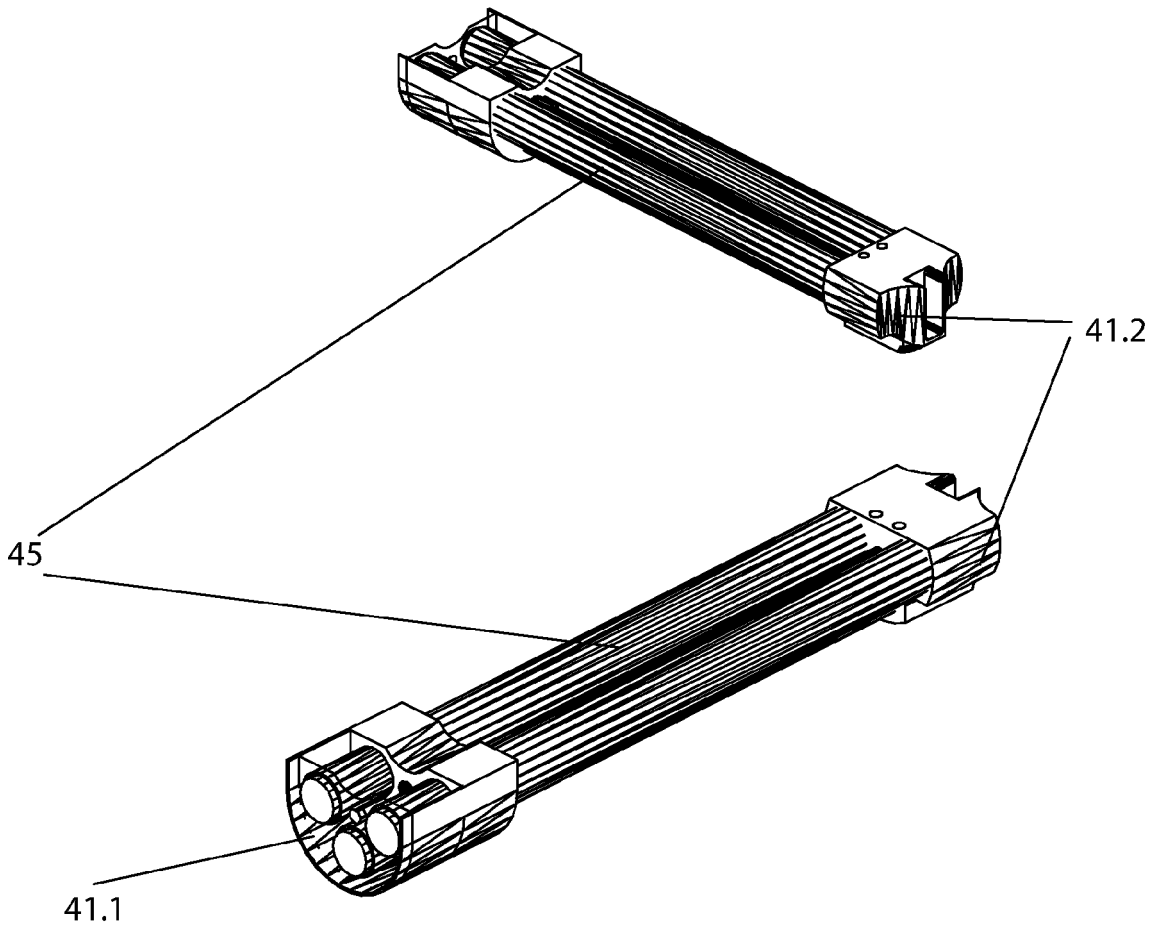
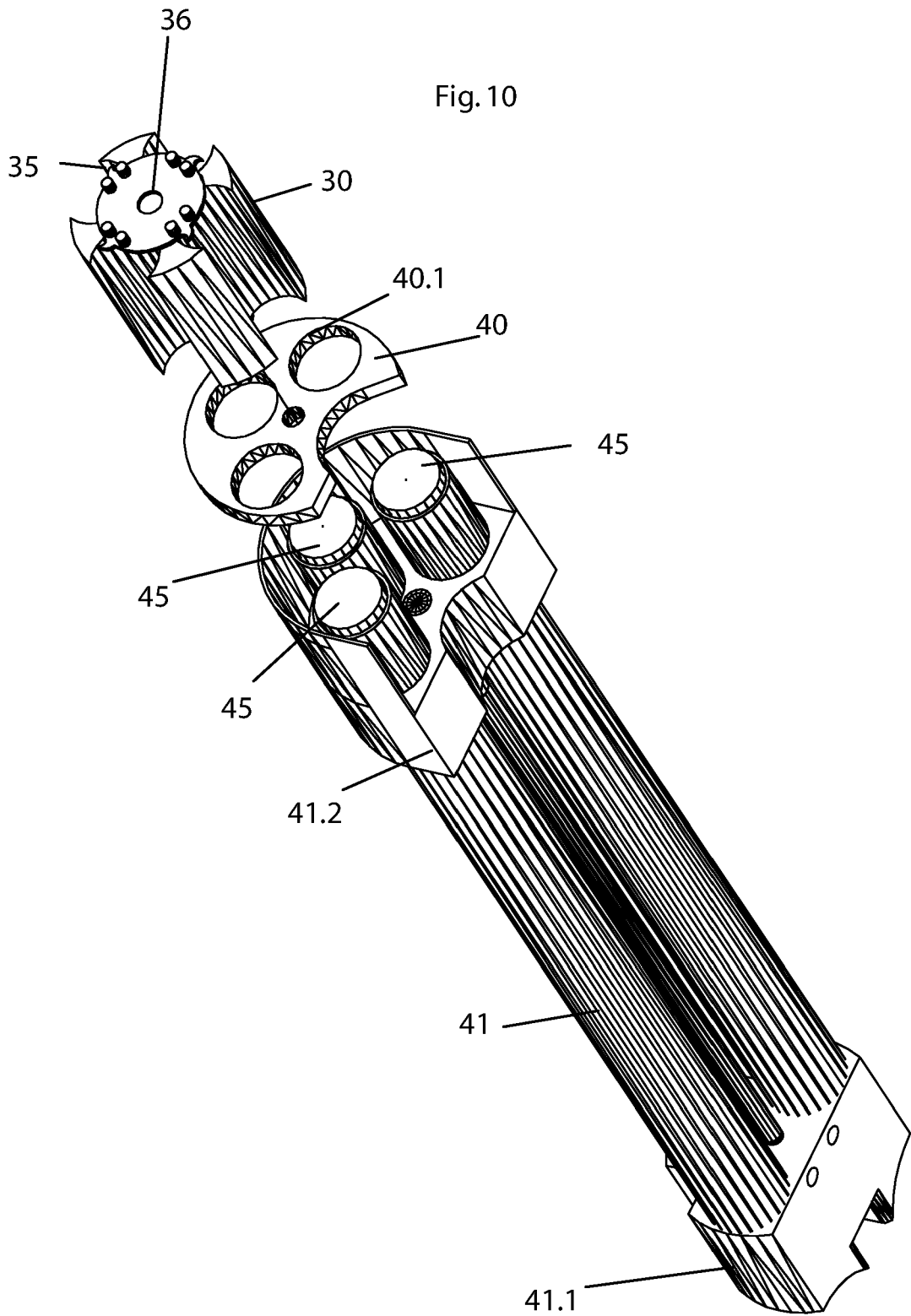

Fig. 9







European Patent Office

**PARTIAL EUROPEAN SEARCH REPORT**

Application Number

which under Rule 45 of the European Patent Convention EP 06 12 2647 shall be considered, for the purposes of subsequent proceedings, as the European search report

DOCUMENTS CONSIDERED TO BE RELEVANT			
Category	Citation of document with indication, where appropriate, of relevant passages	Relevant to claim	CLASSIFICATION OF THE APPLICATION (IPC)
Y	WO 03/078915 A (SNAKE RIVER MACHINE INC [US]) 25 September 2003 (2003-09-25) * page 4, line 5 - page 6, line 13 * * page 6, line 33 - page 9, line 31 * * figures * -----	1,3,4, 6-9	INV. F41A9/02 F41A9/72  ADD. F41A17/56
Y	US 4 644 930 A (MAINHARDT ROBERT [US]) 24 February 1987 (1987-02-24) * figure 2 * -----	1,3,4, 6-9	
Y	US 4 207 797 A (GYORIK JOSEPH J [US]) 17 June 1980 (1980-06-17) * column 2, line 35 - column 6, line 34 * * figures * -----	1,3,4, 6-9	
A	US 5 119 575 A (GAJDICA MICHAEL S [US]) 9 June 1992 (1992-06-09) * column 3, line 45 - column 7, line 26 * * figures * -----	1,2	
A	US 575 265 A (S. N. MCCLEAN) 12 January 1897 (1897-01-12) * the whole document * -----	1,2	TECHNICAL FIELDS SEARCHED (IPC)  F41C F41A
-/--			
INCOMPLETE SEARCH			
<p>The Search Division considers that the present application, or one or more of its claims, does/do not comply with the EPC to such an extent that a meaningful search into the state of the art cannot be carried out, or can only be carried out partially, for these claims.</p> <p>Claims searched completely :</p> <p>Claims searched incompletely :</p> <p>Claims not searched :</p> <p>Reason for the limitation of the search: see sheet C</p>			
Place of search <b>The Hague</b>		Date of completion of the search <b>4 April 2007</b>	Examiner <b>GEX-COLLET, A</b>
<b>CATEGORY OF CITED DOCUMENTS</b> X : particularly relevant if taken alone Y : particularly relevant if combined with another document of the same category A : technological background O : non-written disclosure P : intermediate document		T : theory or principle underlying the invention E : earlier patent document, but published on, or after the filing date D : document cited in the application L : document cited for other reasons ..... & : member of the same patent family, corresponding document	

3  
EPO FORM 1503 03.82 (P04C07)



DOCUMENTS CONSIDERED TO BE RELEVANT			CLASSIFICATION OF THE APPLICATION (IPC)
Category	Citation of document with indication, where appropriate, of relevant passages	Relevant to claim	
A	US 580 679 A (W. H. DAVENPORT) 13 April 1897 (1897-04-13) * the whole document *	1,2	
A	US 4 709 617 A (ANDERSON JOHN A [US]) 1 December 1987 (1987-12-01) * figure 5 *	1,2,6	
A	US 2006/101692 A1 (FALENWOLFE PATRICK [US]) 18 May 2006 (2006-05-18) * figures 1,8,9 *	1,2,6	
			TECHNICAL FIELDS SEARCHED (IPC)



Claim(s) searched completely:  
1,3-10

Claim(s) not searched:  
2

Reason for the limitation of the search:

The application does not meet the requirements of Article 83 EPC, because the subject-matter of claim 2 is not disclosed with sufficient clarity.

The description and drawings only relate to embodiments with a cylinder integrated into the receiver. In claim 2, the cylinder is supposed to be located between the magazine and the receiver. In the light of the description, the sole purpose of the cylinder is to move the cartridge from the tubular magazine directly to the firing chamber, which appears impossible (without any additional, undisclosed conveying means from the external cylinder into the receiver and up into the chamber) when the cylinder is not integrated into the receiver. Therefore the subject-matter of independent claim 2 is not disclosed in a manner sufficiently clear and complete for it to be carried out by a person skilled in the art.

**ANNEX TO THE EUROPEAN SEARCH REPORT  
ON EUROPEAN PATENT APPLICATION NO.**

EP 06 12 2647

This annex lists the patent family members relating to the patent documents cited in the above-mentioned European search report. The members are as contained in the European Patent Office EDP file on  
The European Patent Office is in no way liable for these particulars which are merely given for the purpose of information.

04-04-2007

Patent document cited in search report		Publication date	Patent family member(s)	Publication date
WO 03078915	A	25-09-2003	AU 2003213825 A1	29-09-2003
			US 2004020093 A1	05-02-2004
			US 2005241204 A1	03-11-2005
-----				
US 4644930	A	24-02-1987	NONE	
-----				
US 4207797	A	17-06-1980	NONE	
-----				
US 5119575	A	09-06-1992	NONE	
-----				
US 575265	A		NONE	
-----				
US 580679	A		NONE	
-----				
US 4709617	A	01-12-1987	NONE	
-----				
US 2006101692	A1	18-05-2006	NONE	
-----				

EPO FORM P0459

For more details about this annex : see Official Journal of the European Patent Office, No. 12/82