

(No Model.)

O. D. McCLELLAN.  
GAS BURNER.

No. 336,418.

Patented Feb. 16, 1886.

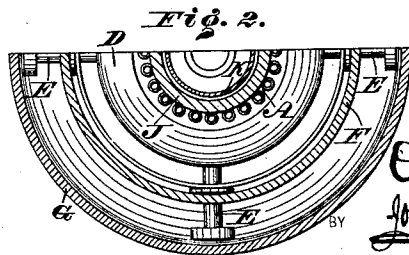
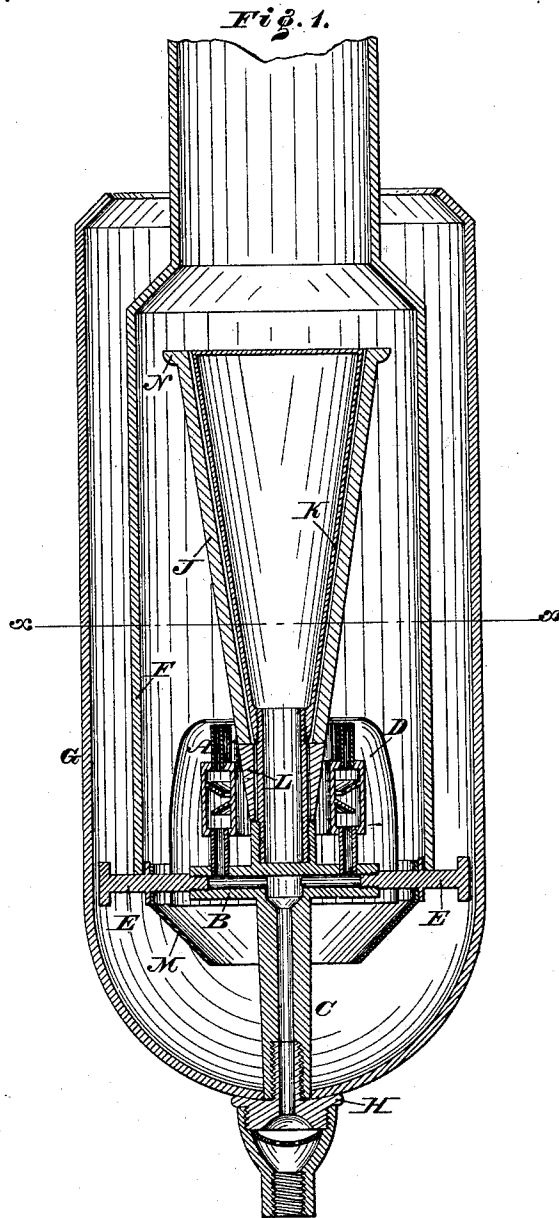

WITNESSES:  
*L. Douville*  
*H. P. Fischer*

INVENTOR:  
*Oscar D. McClellan*  
BY *John A. Diederichsen*  
ATTORNEY.

# UNITED STATES PATENT OFFICE.

OSCAR D. McCLELLAN, OF PHILADELPHIA, PENNSYLVANIA, ASSIGNOR TO  
ADOLPH WASSERMAN, OF SAME PLACE.

## GAS-BURNER.

SPECIFICATION forming part of Letters Patent No. 336,418, dated February 16, 1886.

Application filed May 19, 1885. Serial No. 165,974. (No model.)

To all whom it may concern:

Be it known that I, OSCAR D. McCLELLAN, a citizen of the United States, residing in the city and county of Philadelphia, State of Pennsylvania, have invented a new and useful Improvement in Gas-Burners, which improvement is fully set forth in the following specification and accompanying drawings, in which—

Figure 1 represents a vertical section of a gas-burner embodying my invention. Fig. 2 represents a horizontal section in line *x x*, Fig. 1.

Similar letters of reference indicate corresponding parts in the two figures.

My invention relates to improvements in gas-burners; and it consists of a novel combination of parts, as hereinafter fully set forth, whereby a flame of increased brilliancy is produced at a diminished cost.

It further consists of the deflector having a head of conical form.

It further consists of a gas-burner having means for deflecting air into contact with the chimney, thus highly heating the air and increasing the brilliancy of the flame.

Referring to the drawings, A represents a burner formed of a circular row of tubes, which are supported upon tubular arms B, whereby, by means of a pipe, C, gas may be admitted to the burners. The tubes A pass through a metallic regulator, A', having diaphragms *a*, which regulator serves also as a regulator in aiding to raise the temperature of the gas passing through it.

Surrounding the burners A and sustained on the arms B is a shell or sleeve, D, said arms being provided with supports E for said sleeve, and for a chimney, F, of glass or other suitable transparent material, and surrounding said chimney is a globe, G, which is open at the top, and has a bottom of the form of an inverted cone, the same being closed, excepting at the center, where it surrounds the pipe C, and rests on a collar or shoulder, H, on said pipe, it being noticed that an air-space exists between the chimney and globe and continues below the arms B, so that air is admitted to the top of the globe and directed in hot condition below the burners, shell, and chimney,

and so supplied to the inside and outside of the flame, the closed bottom of the chimney also preventing adverse currents of air from reaching the flame. J represents a deflector, of porcelain or other suitable material, which is of the form of an inverted cone, the same being hollow and fitted over and retained by a similar-shaped core, K, of metal, whose lower end is screwed or otherwise attached to a central ring or annulus, O, secured to the center of the arms B. The advantage of having the said core of conical form is readily apparent, as the deflector J may be constructed of uniform thickness.

L represents a metallic tubular head, which is of the form of an inverted cone with its base above, and upon which rests the deflector, said base and lower end of the deflector being of the same diameter, whereby there is a uniform incline from the lower part of the head to the upper end of the deflector, thus causing air admitted within the flame to reach the extreme tip of the same in an unbroken or direct line without being turned aside from its course, enabling the flame to be extended to a considerable length, and effecting an economical combustion of all of the gas. The tubes A are placed around the regenerator formed by the metallic core K and the deflector J. The head L rests on the center of the arms B, and the lower end of the core K passes through said head, and is screwed or otherwise secured to said arms.

To the support E is secured a deflector-hood, M, of the form of an inverted cone, having a central opening and surrounding the pipe C, and serving to distribute air both outside and inside of the row of burners A.

It will be seen that owing to the deflector being tapering and having its lower end pointed or narrow, it can be used in small burners, and serves to produce an extended flame, there being an unobstructed passage of air within the flame along the side of the deflector from below from the commencement of the head L to the top of the deflector.

The heating of the chimney F serves to raise the temperature of the air, which, traversing the space between the same and the globe G and passing under the deflector E, is fed to the

burners, thereby increasing the brilliancy of the flame and thoroughly consuming the gas.

At the top of the deflector J is a flange or lip, N, and the portion of the chimney F just above said lip is contracted, or formed with a neck, whereby the flame is even at top and steady in its nature.

Having thus described my invention, what I claim as new, and desire to secure by Letters Patent, is—

1. The burner A, consisting of a circular row of tubes, in combination with arms B, supporting said burners A, supports E, deflector M, secured to said supports E, pipe C, and globe G, substantially as and for the purpose set forth.

2. The gas-burner A, in combination with the globe G, having an opening in the top smaller than the body thereof, and the inner

chimney, F, having a neck, and the deflector M, extending below the said chimney, the said globe extending above the body of the said chimney and resting on a shoulder of the supply-gas pipe, substantially as described.

3. An inlet-pipe, in combination with a circular row of burners, a shell surrounding said burners, a chimney, a globe closed at the bottom and encircling said chimney, and a central deflector within said row of burners and extending above the same, and a deflector extending below the said burners within said globe, substantially as and for the purpose set forth.

OSCAR D. McCLELLAN.

Witnesses:

JOHN A. WIEDERSHEIM,  
A. P. GRANT.