

(12) PATENT
(19) AUSTRALIAN PATENT OFFICE

(11) Application No. AU 200032781 B2
(10) Patent No. 764042

(54) Title
Method for creating secondary sidetracks in a well system

(51)⁶ International Patent Classification(s)
E21B 043/10

(21) Application No: 200032781 (22) Application Date: 2000.02.01

(87) WIPO No: W000/46484

(30) Priority Data

(31) Number	(32) Date	(33) Country
99300717	1999.02.01	EP

(43) Publication Date : 2000.08.25
(43) Publication Journal Date : 2000.10.26
(44) Accepted Journal Date : 2003.08.07

(71) Applicant(s)
Shell Internationale Research Maatschappij B.V.

(72) Inventor(s)
Markus Antonius Van Buren; Johannes, Henricus, Gerardus Surewaard

(74) Agent/Attorney
Davies Collison Cave, 1 Little Collins Street, MELBOURNE VIC 3000

(56) Related Art
US 5348095
EP 0310215
"HOW MULTILATERAL.." V.57(1) 01.07.97 P.46,48,80_XP000721794

52781/00



PCT

WORLD INTELLECTUAL PROPERTY ORGANIZATION
International Bureau

INTERNATIONAL APPLICATION PUBLISHED UNDER THE PATENT COOPERATION TREATY (PCT)

<p>(51) International Patent Classification ⁷ : E21B 43/10</p>	<p>A1</p>	<p>(11) International Publication Number: WO 00/46484 (43) International Publication Date: 10 August 2000 (10.08.00)</p>
<p>(21) International Application Number: PCT/EP00/00791 (22) International Filing Date: 1 February 2000 (01.02.00) (30) Priority Data: 99300717.8 1 February 1999 (01.02.99) EP (71) Applicant (for all designated States except CA): SHELL INTERNATIONALE RESEARCH MAATSCHAPPIJ B.V. [NL/NL]; Carel Van Bylandtlaan 30, NL-2596 HR The Hague (NL). (71) Applicant (for CA only): SHELL CANADA LIMITED [CA/CA]; 400 - 4th Avenue S.W., Calgary, Alberta T2P 2H5 (CA). (72) Inventors: VAN BUREN, Markus, Antonius; PDO Office, Mina Al Fahal, 113 Muscat (OM). SUREWAARD, Johannes, Henricus, Gerardus; PDO Office, Mina Al Fahal, 113 Muscat (OM).</p>	<p>(81) Designated States: AE, AL, AM, AT, AU, AZ, BA, BB, BG, BR, BY, CA, CH, CN, CR, CU, CZ, DE, DK, DM, EE, ES, FI, GB, GD, GE, GH, GM, HR, HU, ID, IL, IN, IS, JP, KE, KG, KP, KR, KZ, LC, LK, LR, LS, LT, LU, LV, MA, MD, MG, MK, MN, MW, MX, NO, NZ, PL, PT, RO, RU, SD, SE, SG, SI, SK, SL, TJ, TM, TR, TT, TZ, UA, UG, UZ, VN, YU, ZA, ZW, ARIPO patent (GH, GM, KE, LS, MW, SD, SL, SZ, TZ, UG, ZW), Eurasian patent (AM, AZ, BY, KG, KZ, MD, RU, TJ, TM), European patent (AT, BE, CH, CY, DE, DK, ES, FI, FR, GB, GR, IE, IT, LU, MC, NL, PT, SE), OAPI patent (BF, BJ, CF, CG, CI, CM, GA, GN, GW, ML, MR, NE, SN, TD, TG).</p> <p>Published <i>With international search report. Before the expiration of the time limit for amending the claims and to be republished in the event of the receipt of amendments.</i></p>	

(54) Title: METHOD FOR CREATING SECONDARY SIDETRACKS IN A WELL SYSTEM

(57) Abstract

A method is disclosed for creating one or more secondary sidetracks in an oil and/or gas well assembly which comprises a primary wellbore (2) and one or more primary sidetracks (6) so that a root-like multilateral well structure is created. The method makes use of an expandable well liner (9) in the primary sidetracks (6) so as to create a liner having a sufficient internal width to allow sidetracking equipment to be inserted and operated in the primary sidetrack to drill and complete the secondary sidetracks (7).

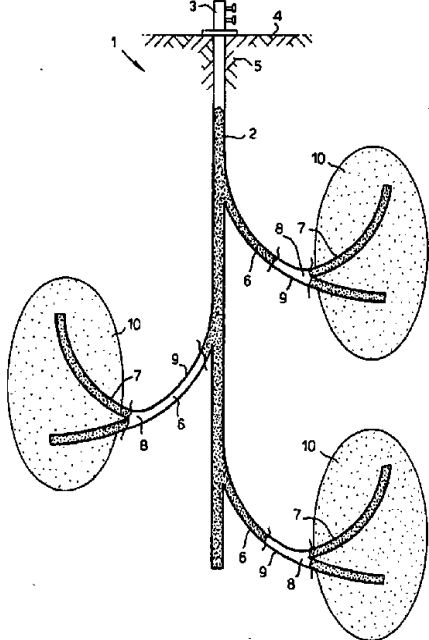

METHOD FOR CREATING SECONDARY SIDETRACKS IN A WELL SYSTEM

Background of the Invention

The invention relates to a method for creating secondary sidetracks in a well system which comprises a main wellbore into which one or more primary sidetracks debouch.

Such a well system is known from International patent application WO 98/49424.

A difficulty which arises with such a well system is that conventional wells have a telescoping nature which stems from the fact that a casing is inserted into the main well at various stages of the drilling process and casing sections which are inserted thereafter need to have a smaller outer diameter than the inner diameter of the previously installed casing sections, and that the liner which is subsequently inserted into the primary sidetrack needs to have an outer diameter which is significantly smaller than the inner diameter of the casing of the main wellbore at the branchpoint in order to allow a smooth insertion of the liner from the main wellbore into the primary sidetrack.

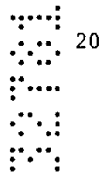

As a result the liner of the primary sidetrack has such a small diameter that it is hardly feasible and economically unattractive to drill secondary sidetracks away from the primary sidetrack.

Accordingly, the present invention seeks to provide a method for creating one or more secondary sidetracks in a well system in an efficient and economical manner.

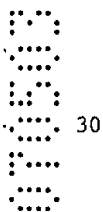
Summary of the Invention

In accordance with the present invention a method is provided for creating a secondary sidetrack in a well system for production of hydrocarbon fluids from a hydrocarbon formation, which

- 2 -

well system comprises a main wellbore and a primary sidetrack which debouches into the main wellbore, the method comprising:

- 5 - inserting an unexpanded expandable steel unslotted tubular liner into the primary sidetrack;
- radially expanding the liner;
- creating an opening in the wall of the expanded liner; and
- 10 - drilling a secondary sidetrack into the hydrocarbon formation through said opening.

Preferably the expandable steel liner which is expanded by pushing or pulling an expansion mandrel which is provided with a conical wear-resistant outer surface and/or rollers through the liner.

15 The expanded liner has an internal diameter which is sufficiently large to allow drilling and/or kick off equipment to be inserted into the primary sidetrack for drilling of one or more secondary sidetrack, which also have an internal width which is sufficiently large to
20 serve as a wellbranch through which hydrocarbon fluids can flow into the well system.

25 Hence the method according to the invention allows to create a root-like well system which provides an optimal drainage of hydrocarbon fluids from a hydrocarbon bearing formation, even if the formation has a low permeability.

In an attractive embodiment of the method according to the invention the expandable liner is formed by a coiled tubing through which drilling fluid is pumped towards a downhole drilling assembly which is used to drill the primary sidetrack and which coiled tubing is radially expanded after the primary sidetrack has been drilled.

30
35 Also the secondary sidetrack may be drilled using a coiled tubing which is expanded to form an expanded liner after completion of the drilling activities.

Alternatively the secondary sidetrack may be lined using an expandable slotted liner of which the slots are staggered and open up into diamond shaped apertures upon expansion of the liner. Such an expandable slotted line
5 is known from US patent No. 5,366,012. Such a slotted liner may be surrounded in the inflow region of the secondary sidetrack by an expandable sandscreen, such as a sandscreen which is disclosed in International patent application PCT/EP96/04887.

10 In stable reservoir formations the secondary sidetrack may be an open uncased hole whereas if the reservoir formation is very unstable the secondary sidetrack may be lined with an initially unslotted expanded or unexpanded liner into which perforations are
15 shot using a perforation gun which is known per se.

The invention also relates to a root-like well system which has been created in accordance with the invention and which comprises a main wellbore into which one or more primary sidetracks comprising an expanded expandable
20 steel unslotted tubular liner debouch and one or more secondary sidetracks which debouch into the primary sidetrack or sidetracks through one or more openings in the wall of the expanded liner of liners.

25 It will be understood that the use of expandable tubulars in a multilateral well system makes it possible that the well tubulars in the primary or mother well and in the primary and secondary sidetracks or well branches have a substantially equal internal width, so that a monobore multilateral well is created. In such a monobore well system it is possible to drill tertiary sidetracks
30 away from the secondary sidetracks, which sidetracking process can be repeated again and again so that a truly root-like multilateral well system is created.

Brief Description of the drawings

Preferred embodiments of the method and system according to the present invention will be described with reference to the drawings, in which:

5 Fig. 1 is a schematic vertical sectional view of a well system according to the invention; and

Fig. 2 is a schematic vertical sectional view of a well system according to the invention, which comprises a primary sidetrack into which two secondary sidetracks debouch.

10

Detailed Description of preferred Embodiments

Referring now to Fig. 1 there is shown a well system 1 according to the present invention which comprises a vertical main wellbore 2 which extends from a wellhead 3 at or near the earth surface 4 into a subsurface formation 5. Three primary sidetracks 6 debouch into the main wellbore 2. A secondary sidetrack 7 debouches into each primary sidetrack 6 through an opening 8 in the wall of an expanded expandable steel liner 9, of which only the section in the region of each opening 8 is shown.

15

20

The expanded expandable liner 9 of each primary side track 6 is formed from an unslotted coiled tubing through which drilling fluid may be pumped towards a downhole drilling assembly that is used to drill the primary sidetrack. The coiled tubing is radially expanded after the primary sidetrack 6 has been drilled and may be slotted upstream of the opening to facilitate collection of hydrocarbon fluid from the formation 10 by the lined primary sidetrack 6.

25

The use of expanded liners 9 maximizes the internal width of the liners 9. Thus, if the wellbore of each sidetrack has a width of about 10 cm, the expanded liner may have an internal width of about seven to eight centimetres.

30

Such an internal width is a minimal requirement to

35

- 4a -

allow a drilling assembly to be inserted into the primary sidetracks 6 which can be used to drill secondary sidetracks 7 of a sufficient width which is necessary to allow hydrocarbon fluids to flow in sufficient quantities
5 through the secondary sidetracks 7 into the primary sidetracks.

Preferably also the main wellbore 2 is cased with an expandable steel casing which is cladded against the wellbore during the expansion process in a similar manner .

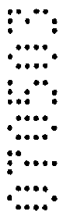

as the expandable liners 9 have been cladded against the wellbore of the primary sidetracks 6.

This allows a further increase in the internal width of the liners 9 and of the secondary sidetracks 7.

5 The primary and secondary sidetracks 6 and 7 each extend into hydrocarbon fluid bearing formations 10 which are shown as shaded areas in the drawing.

10 It will be understood that the illustrated well system provides a root-like well configuration which provides an optimum drainage of hydrocarbon fluids from the hydrocarbon fluid bearing formations 10.

Referring now to Fig. 2 there is shown a vertical primary wellbore 20 from which a primary sidetrack 21 has been drilled away in a horizontal direction.

15 The primary sidetrack 21 is lined with an expandable steel liner 22. Preferably the liner 22 is formed by a coiled tubing which has been used during drilling to feed drilling fluid to a drill bit (not shown) and to a hydraulic downhole mud motor (not shown) which is used to rotate the drill bit.

20 After completion of drilling the coiled tubing is expanded such that it is cladded against the wellbore and subsequently serves as a steel lining of the wellbore of the primary sidetrack 21.

25 Subsequently a 4.5 inch (= about 12 cm) shoe 27 and a plug 23 are installed near the toe 24 of the primary sidetrack 21 inside the liner 22.

30 Then a whipstock 25 is inserted and anchored within the liner 22 and a hanger 26 having an internal width of about 7 cm is inserted into the expanded liner 22 which has an internal width of about 10 cm. Then a drilling assembly (not shown) is inserted through the hanger 26 and is induced by the whipstock 25 to mill an opening into the liner 22 and to subsequently drill the secondary

sidetrack 30 into a hydrocarbon fluid bearing formation 31.

5 In the example shown a conventional steel liner 31 has been inserted into the secondary sidetrack 30 which has an outer diameter of about 7 cm and which is perforated in the well inflow zone by means of a perforating gun (not shown).

10 After completion of the first secondary sidetrack 30 another whipstock 32 is inserted and anchored inside the expanded liner 22 close to the heel of the lateral primary sidetrack 21, followed by another hanger 35, whereupon yet another secondary sidetrack 33 is drilled and completed in the same manner as described with reference to the first secondary sidetrack 30.

15 After insertion of a steel liner 34 in the second secondary sidetrack either an opening (not shown) is drilled through the wall of the liner 34 and through the whipstock 32 or an already existing fluid passage in the whipstock and a fluid passage in the hanger 35 are used
20 to allow hydrocarbon fluid to flow from the first secondary sidetrack 30 and through the primary sidetrack 21 into the main wellbore 20.

The reference to any prior art in this specification is not, and should not be taken as, an acknowledgment or any form of suggestion that that prior art forms part of the common general knowledge in Australia.

Throughout this specification and the claims which follow, unless the context requires otherwise, the word "comprise", and variations such as "comprises" and "comprising", will be understood to imply the inclusion of a stated integer or step or group of integers or steps but not the exclusion of any other integer or step or group of integers or steps.

THE CLAIMS DEFINING THE INVENTION ARE AS FOLLOWS:

1. A method for creating a secondary sidetrack in a well system for production of hydrocarbon fluids from a hydrocarbon formation, which well system comprises a main wellbore and a primary sidetrack which debouches into the main wellbore, the method comprising:
 - inserting an unexpanded expandable steel unslotted tubular liner into the primary sidetrack;
 - 10 - radially expanding the liner;
 - creating an opening in the wall of the expanded liner; and
 - drilling a secondary sidetrack into the hydrocarbon formation through said opening.
- 15 2. The method according to claim 1, wherein the expandable liner is formed by a coiled tubing through which drilling fluid is pumped towards a downhole drilling assembly which is used to drill the primary sidetrack and which coiled tubing is radially expanded after the primary sidetrack has
20 been drilled.
3. The method according to claim 1 or 2, wherein the secondary sidetrack is drilled with a drilling assembly which is connected to a coiled tubing, which tubing is expanded after the secondary sidetrack has been drilled to
25 form a lining in the secondary sidetrack.
4. The method according to claim 1 or 2, wherein the secondary sidetrack is lined along at least part of its length with an expandable slotted liner which is expanded inside the secondary sidetrack such that a series of
30 staggered slots in the liner open up into diamond shaped apertures.
5. The method according to claim 4, wherein an expandable sandscreen is arranged around the expandable slotted liner

in the zone where hydrocarbon fluids flow into the well system.

6. The method according to claim 1, wherein an unexpandable liner is inserted into the secondary sidetrack 5 which liner is perforated in the zone where hydrocarbon fluids flow into the well system.

7. The method according to claim 1, wherein the secondary sidetrack is uncased along at least part of its length.

8. The method according to any one of claims 1 to 7, 10 wherein a plurality of primary sidetracks debouch into the main wellbore and wherein a plurality of secondary sidetracks debouch into at least one of the primary sidetracks.

9. A well system comprising a main wellbore, at least one 15 primary sidetrack and at least one secondary sidetrack, wherein the primary sidetrack comprises an expanded expandable steel unslotted tubular liner which comprises an opening into which a secondary sidetrack debouches, and wherein the primary sidetrack debouches into the main 20 wellbore.

10. The well system of claim 9, wherein the expanded liner in the primary sidetrack has an internal width which is substantially equal to the internal width of a casing in the main wellbore.

25 11. The well system of claim 9 or 10, wherein one or more tertiary sidetracks debouch into at least one secondary sidetrack so that a root-like multilateral well system is created.

12. A method according to claim 1 substantially as 30 hereinbefore described.

- 9 -

13. A well system substantially as hereinbefore described with reference to Figures 1 and 2.

DATED this 5th day of May, 2003

5 **SHELL INTERNATIONALE RESEARCH MAATSCHAPPIJ B.V.**

By DAVIES COLLISON CAVE

Patent Attorneys for the Applicants

5
S
H
E
L
L

5
S
H
E
L
L

1/2

Fig.1.

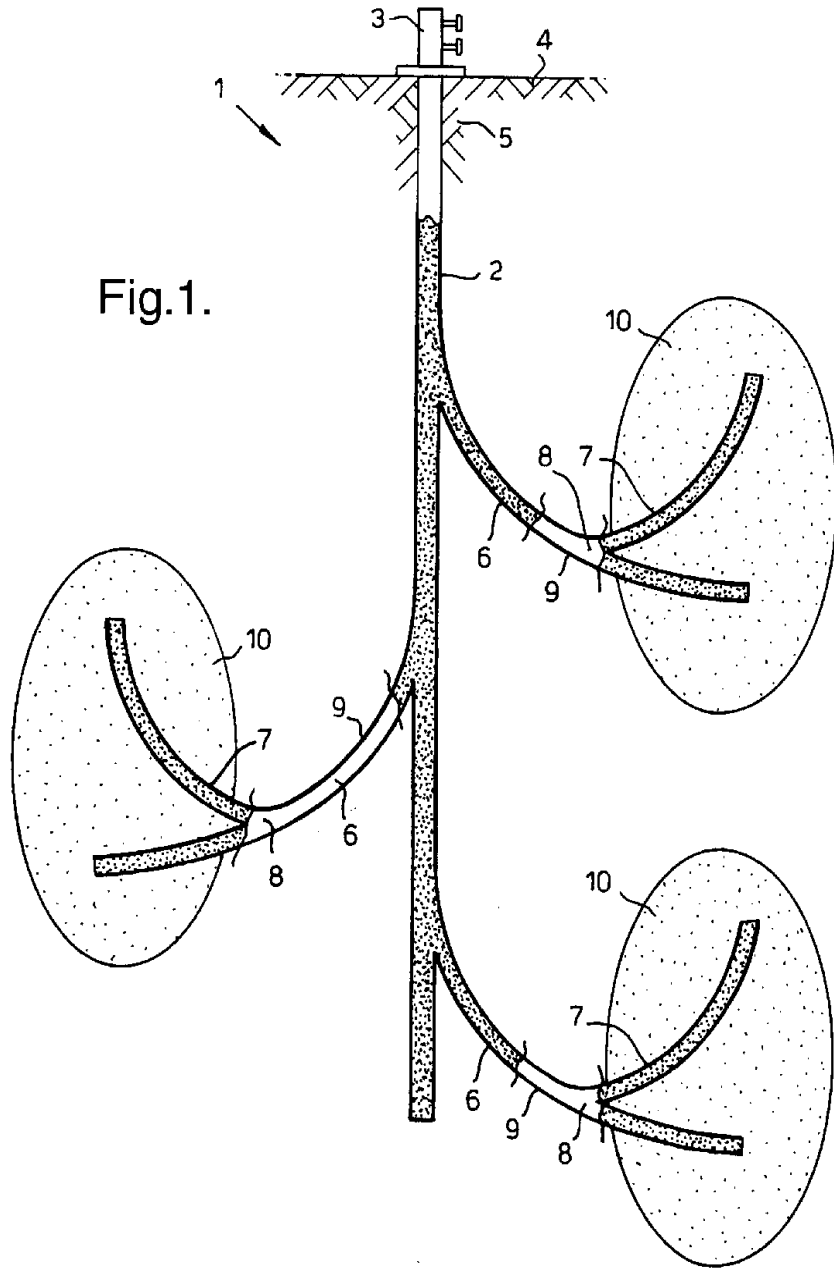

00000 32703

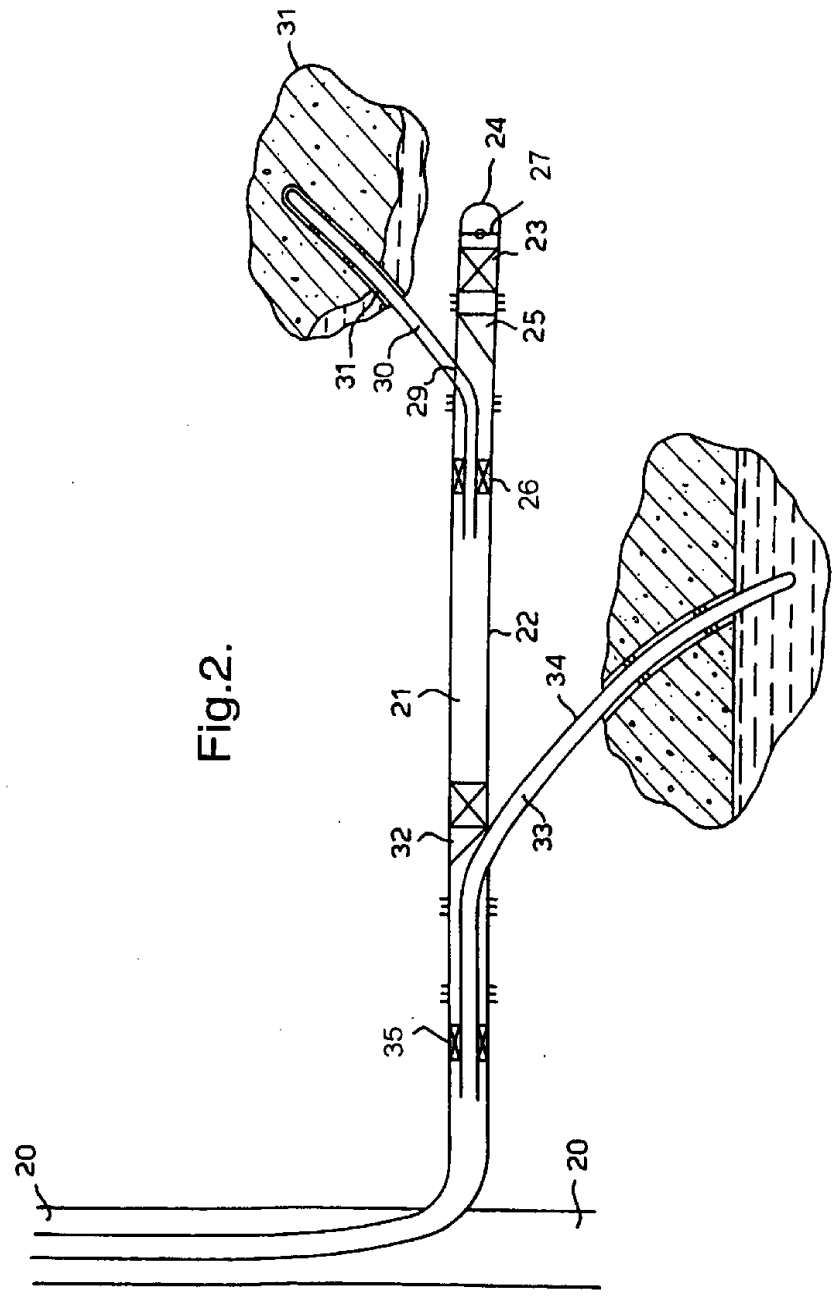

Fig.2.