

(No Model.)

A. McK. WYLIE.

STEAM BOILER.

No. 244,707.

Patented July 19, 1881.

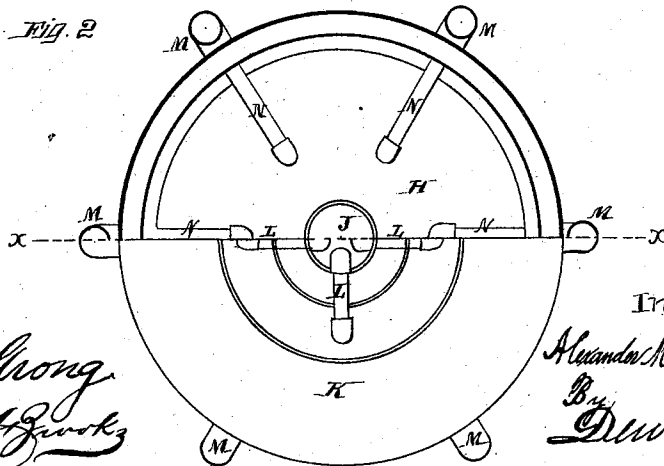
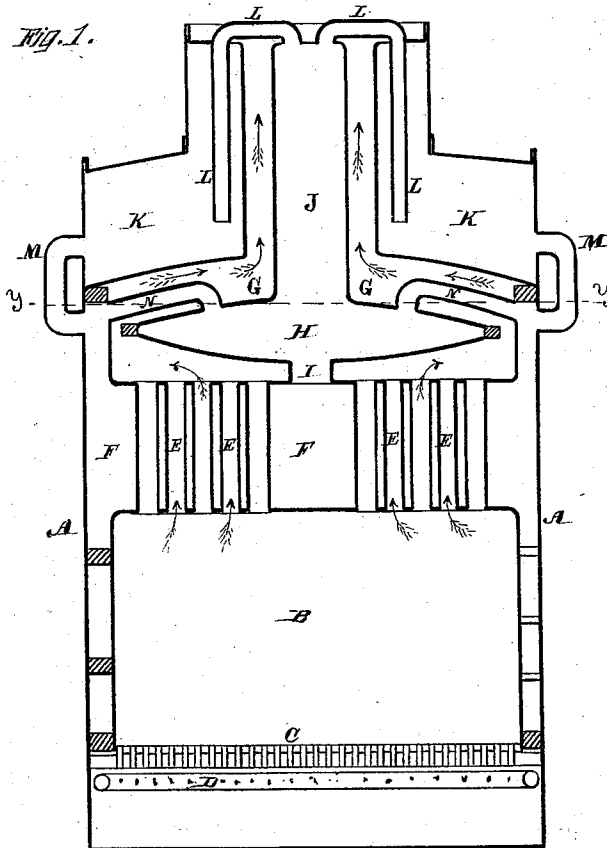

Witnesses

Geo. B. Strong
Frank A. Jewell

Inventor

Alexander McK. Wylie
By Duwey & Co. Attys.

UNITED STATES PATENT OFFICE.

ALEXANDER MCK. WYLIE, OF SAN FRANCISCO, CALIFORNIA.

STEAM-BOILER.

SPECIFICATION forming part of Letters Patent No. 244,707, dated July 19, 1881.

Application filed November 12, 1880. (No model.)

To all whom it may concern:

Be it known that I, ALEXANDER MCKAY WYLIE, of the city and county of San Francisco, State of California, have invented an Improved Steam-Boiler; and I hereby declare the following to be a full, clear, and exact description thereof.

My invention relates to certain improvements in steam-boilers; and it consists in a novel construction of a vertical boiler, with means for providing a complete circulation within it and for exposing the water contained within it to the action of the heat in the most thorough manner, as will be more fully described by reference to the accompanying drawings, in which—

Figure 1 is a vertical section of my boiler, taken through *x x*, Fig. 2. Fig. 2 is a top view of half of the boiler and a horizontal section of one-half, taken through *y y*, Fig. 1.

A is the exterior shell of my boiler, and B is the fire-box, having the door at one side, and surrounded by a water-space in the usual manner.

C is the grate, and below this is the ash-pit, which is entirely closed in, and has a pipe or tube, D, extending around it inside and below the grate. This tube is perforated with small holes or nozzles, and receives air from any device which serves to produce a blast through these holes, and thus furnish air for the combustion of the fuel upon the grate above. The amount of air thus furnished is governed by a stop-cock at some convenient point in the supply-pipe.

From the crown-sheet at the top of the fire-box tubes E conduct the heat upward through the water contained in the body F of the boiler and into an open combustion-chamber, G, around a double convex or lenticular-shaped chamber, H, which connects with the body F by means of a passage, I, while another cylindrical passage, J, extends to the top of the boiler. From the combustion-chamber G the

heat and products of combustion pass upward around the interior cylindrical chamber, J, and within the outer steam space or chamber, K, escaping at the top, as shown.

Pipes L connect the top of the chamber J with the steam-chamber K, extending down into it, and pipes M, opening into the sides of this steam-chamber, connect it with the upper part of the chamber F. Other pipes, N, lead from the top of the convex chamber H into the upper part of the chamber F, which extends up far enough to inclose or surround it and the combustion-chamber G.

By this construction the heat has free access to every portion of the boiler and the pipes conveying the water from one part to another, while by their construction and arrangement a complete and rapid circulation is induced.

Having thus described my invention, what I claim as new, and desire to secure by Letters Patent, is—

1. The boiler consisting of the exterior shell, A, fire-box B, water-chamber F, and the vertical flues E, leading through it from the fire-box, as shown, in combination with the annular steam-chamber K, the connecting-pipes, and the intervening annular combustion-chamber, G, substantially as herein described.

2. The boiler consisting of the outer shell, A, fire-box B, water-chamber F, with traversing flues E, and the combustion-chamber G, with the flattened convex chamber H, situated within it and connected with the chamber F and the steam-chamber K by the extensions and pipes, as shown, whereby a complete circulation and heating of the water is effected, substantially as herein described.

In witness whereof I have hereunto set my hand.

A. MCKAY WYLIE.

Witnesses:

GEO. H. STRONG,
S. H. NOURSE.