

(19)



Europäisches Patentamt  
European Patent Office  
Office européen des brevets



(11)

**EP 1 508 663 B1**

(12)

**EUROPEAN PATENT SPECIFICATION**

(45) Date of publication and mention  
of the grant of the patent:  
**09.08.2006 Bulletin 2006/32**

(51) Int Cl.:  
**E05F 1/10<sup>(2006.01)</sup> E04D 13/035<sup>(2006.01)</sup>**  
**E05D 7/086<sup>(2006.01)</sup>**

(21) Application number: **04388056.6**

(22) Date of filing: **19.08.2004**

**(54) An improved pivot window with at least one auxiliary opening device**

Ein verbessertes Drehfenster mit mindestens einer Hilfsvorrichtung zum Öffnen

Une fenêtre pivotante améliorée avec au moins un dispositif auxiliaire d'ouverture

(84) Designated Contracting States:  
**AT BE BG CH CY CZ DE DK EE ES FI FR GB GR  
HU IE IT LI LU MC NL PL PT RO SE SI SK TR**

(30) Priority: **20.08.2003 DK 200301182**

(43) Date of publication of application:  
**23.02.2005 Bulletin 2005/08**

(73) Proprietor: **VKR Holding A/S  
2860 Søborg (DK)**

(72) Inventor: **Börresen, Bjarne  
2860 Søborg (DK)**

(74) Representative: **Carlsson, Eva et al  
Internationalt Patent-Bureau A/S  
Rigensgade 11  
1316 Copenhagen K (DK)**

(56) References cited:  
**EP-A- 0 872 610 DE-A- 2 708 785**  
**FR-A- 2 281 484 FR-A- 2 581 119**

**EP 1 508 663 B1**

Note: Within nine months from the publication of the mention of the grant of the European patent, any person may give notice to the European Patent Office of opposition to the European patent granted. Notice of opposition shall be filed in a written reasoned statement. It shall not be deemed to have been filed until the opposition fee has been paid. (Art. 99(1) European Patent Convention).

## Description

**[0001]** The invention relates to a window comprising a frame and a sash, said sash being connected with the frame by means of a hinge device defining a hinge axis of the window, the frame and the sash each including a first pair of mutually opposite members, and a second pair of mutually opposite members, said first and second pair of frame members defining a frame plane, said hinge device connecting a respective frame and sash member of the second pair of frame and sash members, and a centre line being defined substantially midway between the one and the other of the members of said first pair, the hinge device being mounted in such a position that the hinge axis is situated between said centre line and said one member of said first pair.

**[0002]** Windows of the pivoting or centre-hung type have found widespread acceptance, especially as roof windows, inter alia because this kind of window facilitates easy window cleaning, as the sash comprising the pane can be turned essentially 180° to allow cleaning of the outside surface of the pane from inside the building. A further advantage of this type of window is that it can be fully opened to a position where the sash is turned approximately 90° in which position air inlet is essentially unrestricted. Eventually, a pivoting window provides for an easy operation, partly due to the position of the operating means at the top member of the sash, partly because the weight of the sash is substantially balanced with the hinge axis situated close to the centre line of the window.

**[0003]** On the other hand, the opening area restricted by the frame bottom and side members and the intersection with the sash including the window pane at the hinge axis is, of course, substantially smaller than in a top-hung window of the same size. This entails, i.a., that pivoting windows are not or only rarely used when a large opening area as defined in the above is desired. Such desired applications may e.g. include the use of the window as an emergency escape or emergency access.

**[0004]** In the prior art, there are numerous examples of windows in which it has been sought to combine the advantages of top-hung and pivoting windows.

**[0005]** FR-A-2581119 as well as EP publications Nos. 679774, 679775, 679776 and 972885 each discloses a window, in which a sash is carried in an auxiliary frame or a set of arms. The auxiliary frame or each arm is at one end hingedly connected with the frame top member and at its other end with the sash. The sash is furthermore connected with the frame by means of cooperating sliding means. In this manner, the window may serve as a top-hung window, in which the arms move synchronically with the sash, which is thus rotated about the hinge connection at the frame top member, or as a tilting window. However, due to the desired multiple function of the window, the design is rather elaborate.

**[0006]** In addition, when turning the sash of such windows in relation to the frame, the movement takes place

entirely on one side of the frame. In the case of the window described in FR-A-2581119 entirely on the outside of the frame making the handling difficult. Further, as the handling of the sash entails an active displacement of its centre of gravity, the handling is heavy leading to an increased risk of injuries during handling, in particular when the weather is windy.

**[0007]** With this background it is the object of the present invention to provide a window, in which the advantages of a top-hung and a pivoting window are combined with respect to opening area and ease of operation, but which at the same time is of a simple structure and which may furthermore be produced in a cost-effective manner.

**[0008]** This object is attained by the provision of a window of the kind mentioned in the introduction, which is furthermore characterized in that the hinge device comprises a set of pivot hinges connecting the frame and sash members directly, such that when the window is open, the two sash members constituting the first pair of sash members are located one on each side of the frame plane, that it includes at least one auxiliary opening device, and that one end of said auxiliary opening device is connected with a frame member, and the other end of said auxiliary opening device is connected with a corresponding sash member.

**[0009]** Compared to a traditional pivot window the hinge axis has thus merely been moved towards one member of the frame and sash, respectively, i.e. towards the top or the bottom of the window, and thereby a substantially larger opening is obtained. By the provision of a larger opening, it becomes possible to utilize the window as an emergency escape. In a traditional pivoting window, this would have required either choosing a larger model of the window, which is not always feasible or desirable, or a top-hung window with the disadvantages listed in the

**[0010]** In a traditional pivot window, the hinge axis is substantially coincident with the centre line, i.e. midway between the top and bottom frame members. This means that the weight of the two parts of the sash and pane lying on each side of the hinge axis, when the window is in its open position, is substantially the same, and the window will therefore tend to stay in any given position.

**[0011]** When the hinge axis is moved, this balance is disturbed, and due to gravitational forces the larger part of the sash and pane will be drawn downwards. If the hinge axis is moved upwards in a traditional pivot window, the window will thus tend to fall back against the closed position. This can make it difficult to open the window, and it is particularly disadvantageous, when the window serves as an emergency opening. However, as the window according to the present invention is provided with an auxiliary opening device, this effect is counteracted, without the use of counter balance means. By connecting the ends of the auxiliary opening device to corresponding members of the sash and the frame, a very uncomplicated and reliable transmission of forces is obtained. The

auxiliary opening device may include at least one pressure medium operated cylinder with an operating rod. This is a structurally simple and inexpensive opening device which may be connected with the frame and the sash in a simple manner.

**[0012]** In an advantageous further development, a handle may be provided for releasing the movement of the pressure medium operated cylinder.

**[0013]** In a preferred embodiment, the auxiliary openings device comprises two cylinders arranged one on each side of the window. This constitutes a well balanced construction and allows the use of two relatively cheap standard type cylinders in stead of e.g. one more powerful cylinder. Further the use of two smaller cylinders gives the window a light and symmetrical appearance and may thus be preferable from an aesthetic point of view. This is particularly the case, when the two cylinders are substantially identical. In special cases, where a very particular opening pattern is required, the two cylinders may, however, also be provided to yield different forces and/or have different characteristics.

**[0014]** Preferably, said at least one cylinder is rotationally connected with one of the frame members of said second pair, and the operating rod is rotationally connected with the corresponding sash member.

**[0015]** In an embodiment, which provides for a particularly inconspicuous design of the window, the connection between the cylinder and the frame is positioned in a groove in the frame.

**[0016]** The cylinder or each cylinder is preferably slidably and rotationally connected with the frame member. This provides for optimum operability, as the movement of the sash with respect to the frame is facilitated.

**[0017]** In order to allow for the sash to be moved outside the range provided by the cylinder and operating rod, the connection between the cylinder and the frame may be releasable.

**[0018]** Alternatively, the auxiliary opening device may comprise a spring connected with the hinge device. This design makes it possible to position the auxiliary opening device virtually completely disguised.

**[0019]** Preferably, the hinge axis is positioned in the interval between 1/3 and 2/3 of the distance between the centre line and said one member of said first pair. This provides for a good balance between a relatively large opening on the one hand and a satisfactory operability of the window on the other.

**[0020]** Preferably, the hinge axis is positioned at approximately 1/4 of the distance between the centre line and said one member of said first pair. The one and the other member of said first pair may constitute the top and bottom member, respectively, of the frame and sash. In an advantageous development of this embodiment, the one end of the auxiliary opening device is connected with an upper face of the frame side member, and the other end with a side or lower face of the corresponding sash side member.

**[0021]** The invention will be described in further detail

with reference to the schematic drawings, in which

Fig. 1 shows a perspective view of a window according to the invention,

Fig. 2 shows a diagrammatic side view of a window according to the invention,

Fig. 3 shows a side view of an embodiment of the window according to the invention,

Fig. 4 shows a perspective view of the frame of a window in an embodiment of the invention, and

Fig. 5 shows, on a larger scale, a partial view of a further embodiment of the connection between the auxiliary opening device and the frame of the window according to the invention

**[0022]** The window shown in Fig. 1 comprises a frame 1 with a first and a second pair of mutually opposite frame members. The first pair consists of one member in the form of a top member 3 and another member in the form of a bottom member 4. The two members of the second pair constitutes side members 5 and 6, each extending between the top and bottom members 3 and 4 to form a substantially rectangular frame 1 intended to be built-in in e.g. an inclined roof (not shown). A sash generally designated 2 is constructed in a similar manner with a top member 7, a bottom member 8 and side members 9, 10. In the sash 2 a window pane 11 of any type, e.g. an insulating unit, is enchased.

**[0023]** The sash 2 is connected with the frame 1 by means of a hinge device, which in the embodiment shown comprises a set of hinges, of which one hinge 12 is shown in Fig. 1, at corresponding side members 5 and 9, and 6 and 10, respectively, of the frame 1 and sash 2. The set of hinges may be designed in any suitable manner, e.g. as disclosed in Applicant's European patent No. 1038083. The use of a pivot hinge makes it possible to establish an overlap between the sash and the frame in the closed position of the window, without the use of elaborate devices such as linkage mechanisms. This is a particularly important feature in windows installed in a roof. Several other parts of a traditional pivoting window may be simply transferred to the window according to the invention, possibly following a slight adaptation. This includes, i.a., some of the cladding parts that protect the frame and the sash, which are traditionally formed of wood, from the weather.

**[0024]** As shown in Fig. 2, the set of hinges 12 define a hinge axis 13 extending substantially perpendicular to the plane of the Fig. 2. The hinges 12 are positioned between the top members 3 and 7 of the frame 1 and the sash 2, respectively, and a centre line 14 of the window. The centre line 14 is situated substantially midway between the top and bottom members 3 and 4 of the frame 1, corresponding in substance to the position midway between the top and bottom members 7 and 8 of the sash 2. The position of the hinge axis 13 is chosen in such a way that a suitable balance between ease of operation of the window and a suitable opening defined by the bot-

tom member 4, the side members 5 and 6, and the intersection of the sash 2 including the pane 11 at the hinge axis 13. Preferably, the distance  $d$  between the hinge axis 13 and the centre line 14 of the window lies in the interval between  $1/3$  and  $2/3$  of the distance between the centre line 14 and the top member 3 of the frame 1.

**[0025]** In order to bring the window from the closed position to an open position, e.g. a ventilating position, operating means are provided. In the embodiment of Fig. 2, the operating means comprises a ventilating flap 15 on the sash top member 7. In a manner that is well known per se, the ventilating flap 15 includes engagement means for cooperation with engagement means on the frame top member 3.

**[0026]** As the hinge axis 13 is displaced from the centre line 14, the sash 2 is not balanced in relation to the frame 1, as is the case in a traditional pivoting window. The force to be exerted by the user when opening the window according to the invention is thus larger than in a traditional window. Therefore, as illustrated in Fig. 3, an auxiliary opening device 120 is provided. Elements having the same or analogous function as in the Fig. 2 embodiment carry the same reference numerals to which 100 has been added. The auxiliary opening device 120 includes a pressure medium operated cylinder 124 with an operating rod 123. At 122, the cylinder 124 is rotationally connected with the frame side member 106, and at 121 the operating rod 123 is rotationally connected with the sash side member 110. The connection between the operating rod 123 and the sash may also be positioned on a side face of the sash side member instead of on the lower face. A corresponding opening device may be provided at the opposite side members of the frame and sash, the two opening devices preferably but not necessarily having the same strength and characteristics. If for example aid is particularly needed at the beginning and the end of the opening movement, but not in the middle, two devices working primarily at the beginning and the end respectively may be employed.

**[0027]** The operating means of this embodiment comprises a handle 115 placed on the sash bottom member 108. By operation of the handle 115 engagement means on the sash bottom member 108 are engaged and disengaged with corresponding engagement means on the frame bottom member 104. The cylinder 124 and the operating rod 123 provide a supplementary torque that helps to rotate the sash 102 with respect to the frame 101. It is also possible to form the arrangement such that the handle 115 at the same time releases the movement of the pressure medium operated cylinder and in turn the sash.

**[0028]** As may be seen more clearly in Fig. 4, the frame member 6, to which the opening device is attached, is provided with a recess 6a. A similar recess (not clearly visible) is present in the opposite frame member 5. This allows the opening device to be attached to the side surface of the frame member as shown in Fig. 4 or to a surface facing upwards as shown in Fig. 5 without ne-

cessitating a gap between the frame and sash. The cylinder thus moves entirely or partly in the recess during operation of the window. An advantage thereof is, that the cylinder will be at least partly hidden behind the frame member when seen from the inside of the building in which the window is installed.

**[0029]** In the alternative embodiment of Fig. 5, in which elements having the same or analogous function as in the embodiment of Fig. 3 and 4 carry the same reference numerals to which 100 has been added, the connection between the cylinder 224 and the frame side member 206 is releasable. The cylinder 224 is at the end opposite the operating rod connected with shaft portion 222a and a transverse portion 222b extending substantially perpendicularly to the shaft portion 222a. The releasable connection may e.g. be carried out as indicated, by the provision of a fixing 225 mounted in a groove 226 in an upper side of the frame side member 206. The upper side may be the upper surface of the frame member or a surface of the recess as shown in Fig. 4 which may in this connection be regarded as a depressed part of the upper surface. The fixing 225 comprises a track 226 having an entrance portion 227 formed in such a manner that the transverse portion 222b may be inserted and moved along the track 226 to an end portion 228. In this position, the transverse portion 222b is preferably retained from moving back along the track 226 in any suitable manner. However, the shaft portion 222a and the cylinder 224 are still able to rotate in order to follow the movement of the sash during opening and closing of the window. By the releasable connection it is possible to open the sash beyond an opening angle which is otherwise delimited by the operational length of the cylinder/operating rod, e.g. in order to bring the sash to a position, in which the outer side of the window pane may be cleaned.

**[0030]** In an alternative, not-shown embodiment, the connection between the cylinder of the auxiliary opening device and the frame member may be slidable and rotational. The end of the cylinder, or an element connected with the end of the cylinder, may e.g. be guided in a track having a number of resting positions, and it is possible to move the end of the cylinder between these positions as it is known per se in many applications.

**[0031]** It should be noted that the cylinder of the auxiliary opening device might as well be connected with the sash member and the operating rod with the frame member, just as the precise position of the auxiliary opening device may vary.

**[0032]** As a further alternative, the auxiliary opening device may comprise a spring, e.g. a torsion spring, connected with the hinge device.

**[0033]** The invention should not be regarded as being limited to the embodiments described in the above, but various modifications and combinations may be carried out. For instance, the window may be built-in in a facade, and the sash may be hingedly connected with the frame with the hinge axis extending in parallel with the side

members of the frame and the sash.

### Claims

1. A window comprising a frame (1;101) and a sash (2; 102), said sash being connected with the frame by means of a hinge device (12;112) defining a hinge axis (13) of the window, the frame and the sash each including a first pair (3,4,7,8;103,104,107,108; 206) of mutually opposite members, and a second pair (5,6,9,10;106,110;206) of mutually opposite members, said first and second pair of frame members defining a frame plane, said hinge device connecting a respective frame and sash member of the second pair of frame and sash members, and a centre line (14) being defined substantially midway between the one and the other of the members of said first pair, the hinge device being mounted in such a position that the hinge axis (13) is situated between said centre line (14) and said one member (3,7;103,107) of said first pair, **characterized in that** the hinge device (12;112) comprises a set of pivot hinges connecting the frame and sash members directly, such that when the window is open, the two sash members constituting the first pair of sash members are located one on each side of the frame plane and that the window includes at least one auxiliary opening device (120), and that one end (122) of said auxiliary opening device is connected with a frame member (106), and the other end (121) of said auxiliary opening device is connected with a corresponding sash member (110).
2. A window as claimed in claim 1, in which one or more of the at least one auxiliary opening device (120;220) comprises a pressure medium operated cylinder (124;224) with an operating rod (123).
3. A window as claimed in claim 2, in which a handle (115) is provided for releasing the movement of the pressure medium operated cylinder (124;224).
4. A window as claimed in claim 2 or 3, in which auxiliary openings device comprises two cylinders arranged one on each side of the window.
5. A window as claimed in claim 4, in which the two cylinders are substantially identical.
6. A window as claimed in claim 4, in which the two cylinders yield different forces and/or have different characteristics.
7. A window as claimed any one of the preceding claims, in which the cylinder (124;224) of the or each auxiliary opening device is rotationally connected (122;222a,222b) with one of the frame members

(106;206) of said second pair, and the corresponding operating rod is rotationally connected (121) with the corresponding sash member (110).

- 5 8. A window as claimed any one of the preceding claims, in which the frame member (6) whereto the auxiliary opening device is connected is provided with a groove (6a) allowing the cylinder and/or the operating rod to move during operation of the window.
- 10 9. A window as claimed in any one of the preceding claims, in which the cylinder of the or each auxiliary opening device is slidably and rotationally connected with the frame member.
- 15 10. A window as claimed in any one of the preceding claims, in which the connection between the auxiliary opening device (220) and the frame (206) is releasable.
- 20 11. A window as claimed in any one of the preceding claims, in which the at least one auxiliary opening device comprises a spring connected with the hinge device.
- 25 12. A window as claimed in any one of the preceding claims, in which the hinge axis (13) is positioned in the interval between 1/3 and 2/3 of the distance (d) between the centre line (14) and said one member (3,7) of said first pair.
- 30 13. A window as claimed in claim 1, in which the hinge axis is positioned at approximately 1/4 of the distance between the centre line and said one member of said first pair.
- 35 14. A window as claimed in any one of the preceding claims, in which the one and the other member of said first pair constitutes the top and bottom member (3,4,7,8), respectively, of the frame (1) and sash (2).
- 40 15. A window as claimed in claim 14, in which the one end of the auxiliary opening device (120,220) is connected with an upper face of the frame side member, and the other end with a side or lower face of the corresponding sash side member.
- 45

### 50 Patentansprüche

1. Fenster, welches einen Blendrahmen (1;101) und einen Flügelrahmen (2;102) umfasst, welcher Flügelrahmen mittels einer eine Scharnierachse (13) des Fensters definierenden Scharniervorrichtung (12; 112) mit dem Blendrahmen verbunden ist, wobei der Blendrahmen und der Flügelrahmen jeweils ein erstes Paar (3,4,7,8;103,104,107, 108;206) von ein-
- 55

- ander gegenüberliegenden Elementen und ein zweites Paar (5,6,9,10; 106.110;206) von einander gegenüberliegenden Elementen umfassen, wobei das erste und zweite Paar von Blendrahmenelementen eine Blendrahmenebene definieren, wobei die Scharniervorrichtung einen Blendrahmen bzw. einen Flügelrahmen des zweiten Paares von Blendrahmen- und Flügelrahmenelementen verbindet, und wobei eine Mittellinie (14) im Wesentlichen auf halbem Wege zwischen dem einen und dem anderen der Elemente des ersten Paares definiert ist, wobei die Scharniervorrichtung in einer derartigen Position montiert ist, dass die Scharnierachse (13) zwischen der genannten Mittellinie (14) und dem genannten einen Element (3,7;103,107) des genannten ersten Paares angeordnet ist, **dadurch gekennzeichnet, dass** die Scharniervorrichtung (12;112) einen Satz von Pivotscharnieren umfasst, die die Blendrahmen- und die Flügelrahmenelemente direkt miteinander verbinden, so dass bei geöffnetem Fenster die beiden Flügelrahmenelemente, die das erste Paar von Flügelrahmenelementen bilden, an jeweils einer Seite der Blendrahmenebene gelagert sind, und dass das Fenster mindestens eine Hilfsvorrichtung zum Öffnen (120) umfasst, und dass ein Ende (122) der genannten Hilfsvorrichtung zum Öffnen mit einem Rahmenstück (106) verbunden ist, und dass das andere Ende (121) der genannten Hilfsvorrichtung zum Öffnen mit einem entsprechenden Flügelrahmenelement (110) verbunden ist.
2. Fenster nach Anspruch 1, bei welchem eine oder mehrere der mindestens einen Hilfsvorrichtung zum Öffnen (120;220) einen druckmittelgesteuerten Zylinder (124;224) mit einer Bedienungsstange (123) umfasst.
  3. Fenster nach Anspruch 2, bei welchem ein Griff (115) zur Freigabe der Bewegung des druckmittelgesteuerten Zylinders (124;224) vorgesehen ist.
  4. Fenster nach den Ansprüchen 2 oder 3, bei welchem die Hilfsvorrichtung zum Öffnen zwei an jeweils einer Seite des Fensters angeordnete Zylinder umfasst.
  5. Fenster nach Anspruch 4, bei welchem die beiden Zylinder im Wesentlichen identisch sind.
  6. Fenster nach Anspruch 4, bei welchem die beiden Zylinder unterschiedliche Kräfte erzeugen und/oder unterschiedliche Charakteristiken aufweisen.
  7. Fenster nach einem der vorhergehenden Ansprüche, bei welchem der Zylinder (124;224) der Hilfsvorrichtung zum Öffnen oder jede Hilfsvorrichtung zum Öffnen mit einem der Blendrahmenelemente (106;206) des genannten zweiten Paares drehbar verbunden (122; 222a,222b) ist, und die entsprechende Bedienungsstange (121) mit dem entsprechenden Flügelrahmenelement (110) drehbar verbunden ist.
  8. Fenster nach einem der vorhergehenden Ansprüche, bei welchem das mit der Hilfsvorrichtung zum Öffnen verbundene Blendrahmenelement (6) mit einer Rille (6a) versehen ist, mittels welcher sich der Zylinder und/oder die Bedienungsstange während der Bedienung des Fensters bewegen kann.
  9. Fenster nach einem der vorhergehenden Ansprüche, bei welchem der Zylinder der Hilfsvorrichtung zum Öffnen oder jede Hilfsvorrichtung zum Öffnen mit dem Blendrahmenelement verschiebbar und drehbar verbunden ist.
  10. Fenster nach einem der vorhergehenden Ansprüche, bei welchem die Verbindung zwischen der Hilfsvorrichtung zum Öffnen (220) und dem Blendrahmen (206) freigegeben werden kann.
  11. Fenster nach einem der vorhergehenden Ansprüche, bei welchem die mindestens eine Hilfsvorrichtung zum Öffnen eine mit der Scharniervorrichtung verbundene Feder umfasst.
  12. Fenster nach einem der vorhergehenden Ansprüche, bei welchem die Scharnierachse (13) im Bereich zwischen 1/3 und 2/3 des Abstandes (d) zwischen der Mittellinie (14) und dem genannten einen Element (3,7) des genannten ersten Paares positioniert ist.
  13. Fenster nach Anspruch 1, bei welchem die Scharnierachse bei etwa 1/4 des Abstandes zwischen der Mittellinie und dem genannten einen Element des genannten ersten Paares positioniert ist.
  14. Fenster nach einem der vorhergehenden Ansprüche, bei welchem das eine und das andere Element des genannten ersten Paares das Kopf- bzw. Bodenelement (3,4,7,8) des Blendrahmens (1) und des Flügelrahmens (2) bilden.
  15. Fenster nach Anspruch 14, bei welchem das eine Ende der Hilfsvorrichtung zum Öffnen (120,220) mit einer oberen Stirnseite des Seitenelementes des Blendrahmens verbunden ist, und das andere Ende mit einer seitlichen oder unteren Stirnseite des entsprechenden Seitenelementes des Flügelrahmens verbunden ist.
- 55 Revendications**
1. Fenêtre comprenant un cadre (1;101) et un ouvrant (2;102), ouvrant qui est relié au cadre au moyen d'un

- dispositif de charnière (12;112) définissant un axe de charnière (13) de la fenêtre, le cadre et l'ouvrant comprenant chacun une première paire (3,4,7,8; 103,104,107,108;206) de parties l'une opposée à l'autre, et une deuxième paire (5,6,9,10;106,110; 206) de parties l'une opposée à l'autre, la dite première et deuxième paire de parties de cadre définissant un plan de cadre, dispositif de charnière qui relie respectivement une partie du cadre et une partie de l'ouvrant de la deuxième paire de parties de cadre et d'ouvrant, et une ligne centrale (14) étant définie essentiellement à mi-chemin entre l'une et l'autre des parties de la dite première paire, dispositif de charnière qui est monté dans une telle position que l'axe de charnière (13) est placé entre la dite ligne centrale (14) et l'une dite partie (3,7;103,107) de la dite première paire, **caractérisée en ce que** le dispositif de charnière (12;112) comprend un jeu de charnières à pivotement reliant directement les parties de cadre et d'ouvrant si bien que lorsque la fenêtre est ouverte, les deux parties d'ouvrant constituant la première paire de parties d'ouvrant sont disposées l'une et l'autre à chaque côté du plan de cadre, et en ce que la fenêtre comprend au moins un dispositif d'ouverture auxiliaire (120), et en ce que l'un bout (122) du dit dispositif d'ouverture auxiliaire est relié à la partie de cadre (106), et l'autre bout (122) du dit dispositif d'ouverture auxiliaire est relié à une partie correspondante d'ouvrant (110).
2. Fenêtre selon la revendication 1, dans laquelle un ou plusieurs de l'au moins un dispositif d'ouverture auxiliaire (120;220) comprend un cylindre à air comprimé (124;224) avec un levier de commande (123).
  3. Fenêtre selon la revendication 2, dans laquelle une poignée (115) est pourvue pour déclencher le mouvement du cylindre à air comprimé (124;224).
  4. Fenêtre selon la revendication 2 ou 3, dans laquelle le dispositif d'ouverture auxiliaire comprend deux cylindres disposés l'un et l'autre à chaque côté de la fenêtre.
  5. Fenêtre selon la revendication 4, dans laquelle les deux cylindres sont essentiellement identiques.
  6. Fenêtre selon la revendication 4, dans laquelle les deux cylindres appliquent différents efforts et/ou présentent différentes caractéristiques.
  7. Fenêtre selon l'une quelconque des revendications précédentes, dans laquelle le cylindre (124;224) du ou de chaque dispositif d'ouverture auxiliaire est relié à pivotement (122;222a,222b) avec l'une des parties de cadre (106;206) de la dite deuxième paire, et le levier de commande correspondant est relié à pivotement (121) avec la partie d'ouvrant (110) correspondante.
  8. Fenêtre selon l'une quelconque des revendications précédentes, dans laquelle la partie de cadre (6) à laquelle le dispositif d'ouverture auxiliaire est relié, est pourvue d'une rainure (6a) permettant le cylindre et/ou le levier de commande de se déplacer lors de l'opération de la fenêtre.
  9. Fenêtre selon l'une quelconque des revendications précédentes, dans laquelle le cylindre du ou de chaque dispositif d'ouverture auxiliaire est relié de manière glissante et à pivotement avec la partie de cadre.
  10. Fenêtre selon l'une quelconque des revendications précédentes, dans laquelle la liaison entre le dispositif d'ouverture auxiliaire (220) et le cadre (206) est débrayable.
  11. Fenêtre selon l'une quelconque des revendications précédentes, dans laquelle l'au moins un dispositif d'ouverture auxiliaire comprend un ressort relié au dispositif de charnière.
  12. Fenêtre selon l'une quelconque des revendications précédentes, dans laquelle l'axe de charnière (13) est situé dans l'intervalle entre 1/3 et 2/3 de la distance (d) entre la ligne centrale (14) et l'une dite partie (3, 7) de la dite première paire.
  13. Fenêtre selon la revendication 1, dans laquelle l'axe de charnière est situé à environ 1/4 de la distance entre la ligne centrale et l'une dite partie de la dite première paire.
  14. Fenêtre selon l'une quelconque des revendications précédentes, dans laquelle l'une ou l'autre partie de la dite première paire constitue respectivement la partie supérieure et inférieure (3,4,7,8) du cadre (1) et de l'ouvrant (2).
  15. Fenêtre selon la revendication 14, dans laquelle l'un bout du dispositif d'ouverture auxiliaire (120,220) est relié à une face supérieure de la partie latérale de cadre, et l'autre bout à une face latérale ou inférieure de la partie latérale correspondante de l'ouvrant.

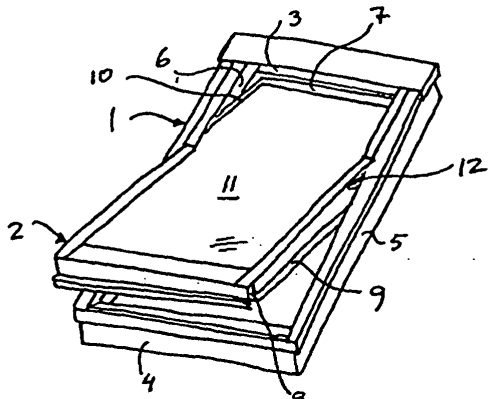

Fig. 1

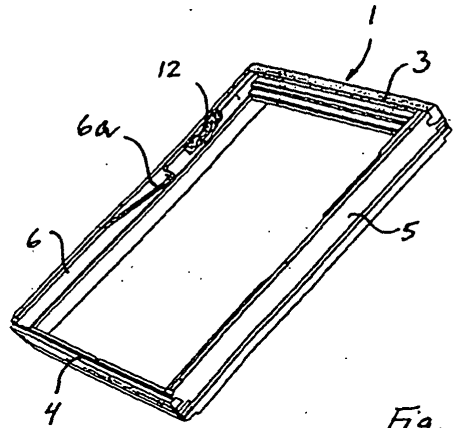

Fig. 4

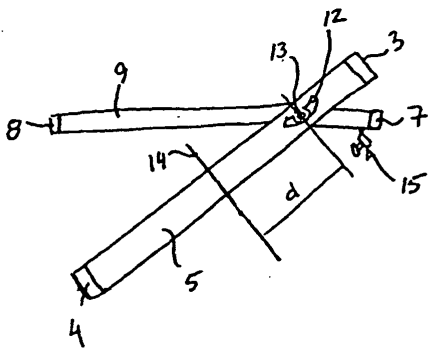

Fig. 2

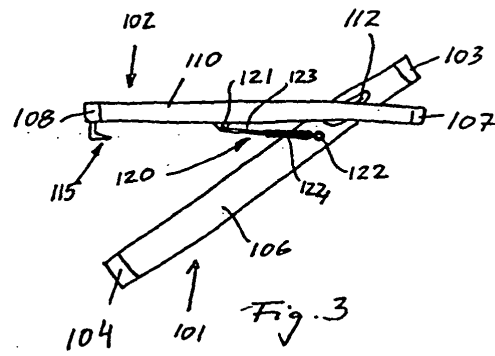

Fig. 3

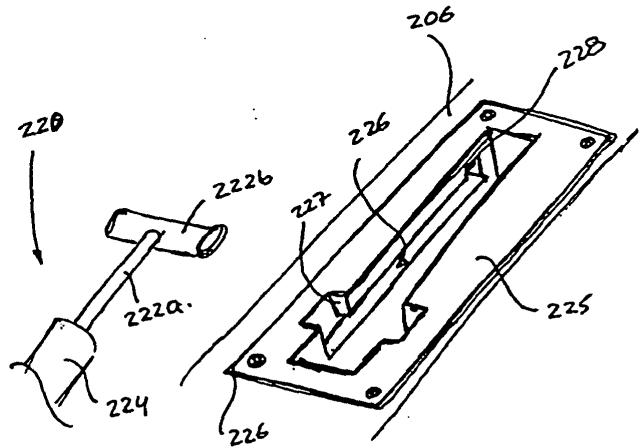

Fig. 5