



US 20140307081A1

(19) **United States**  
(12) **Patent Application Publication**  
**Rudmann et al.**

(10) **Pub. No.: US 2014/0307081 A1**  
(43) **Pub. Date: Oct. 16, 2014**

(54) **WAFER-LEVEL FABRICATION OF OPTICAL DEVICES, IN PARTICULAR OF MODULES FOR COMPUTATIONAL CAMERAS**

**Publication Classification**

(75) Inventors: **Hartmut Rudmann**, Jona (CH); **Matthias Maluck**, Zug (CH); **Alexander Bietsch**, Thalwil (CH); **Peter Roentgen**, Thalwil (CH); **Stephan Heimgartner**, Aarau Rohr (CH)

(51) **Int. Cl.**  
**G02B 13/00** (2006.01)  
**G01J 1/42** (2006.01)  
(52) **U.S. Cl.**  
CPC ..... **G02B 13/0085** (2013.01); **G01J 1/42** (2013.01)  
USPC ..... **348/86**; 359/619; 250/216

(73) Assignee: **HEPTAGON MICRO OPTICS PTE. LTD.**, Singapore (SG)

(57) **ABSTRACT**

(21) Appl. No.: **14/239,334**  
(22) PCT Filed: **Aug. 24, 2012**  
(86) PCT No.: **PCT/CH2012/000200**  
§ 371 (c)(1),  
(2), (4) Date: **Jul. 1, 2014**

The device (50) comprises an optics member (60) and a spacer member (70), said optics member comprising  $N \geq 2$  sets of passive optical components (65) comprising one or more passive optical components each. The spacer member (70) comprises N light channels (77), each of said N light channels being associated with one of said N sets of passive optical components. All of said N light channels (77) have an at least substantially identical geometrical length (g), and an optical path length of a first of said N light channels is different from an optical path length of at least one second of said N light channels. Methods for manufacturing such devices are described, too. The invention can allow to mass produce high-precision devices (50) at a high yield.

**Related U.S. Application Data**

(60) Provisional application No. 61/527,355, filed on Aug. 25, 2011.

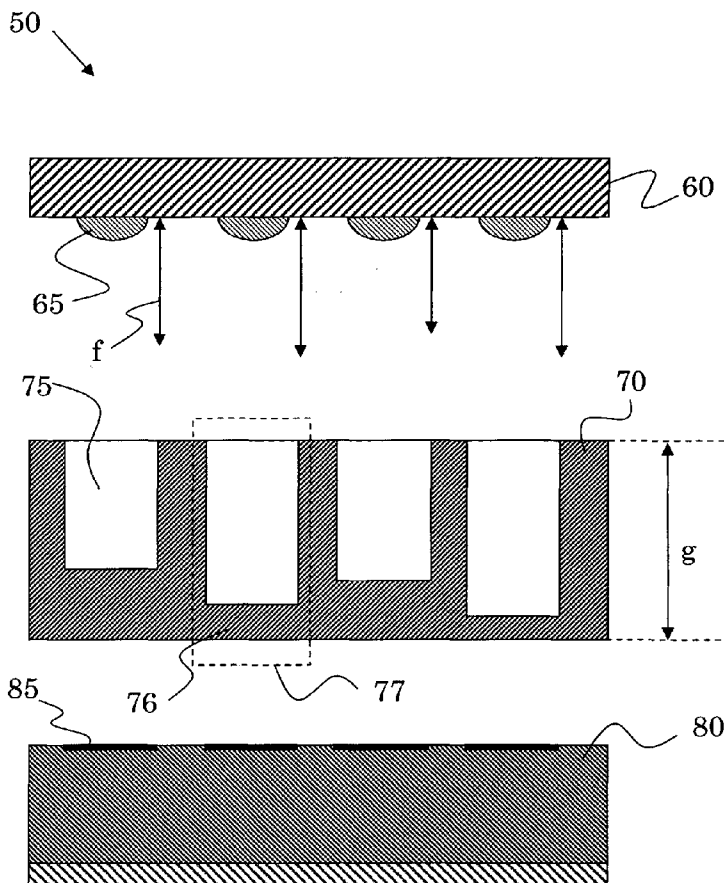

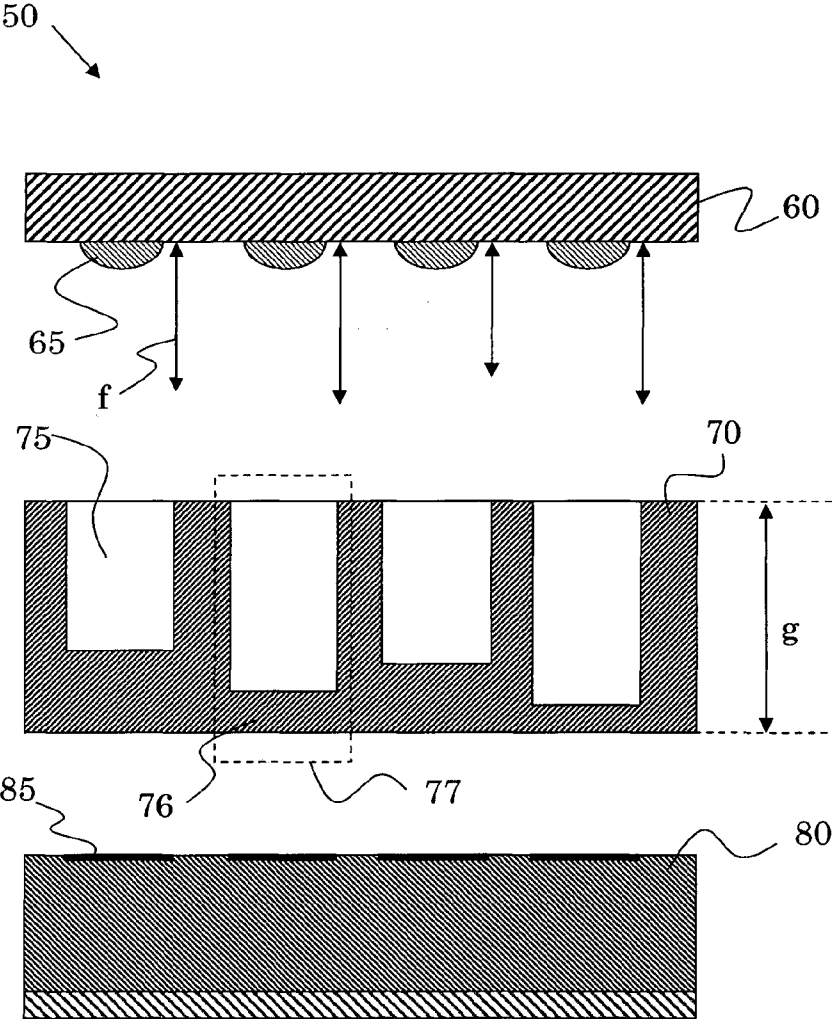

Fig. 1

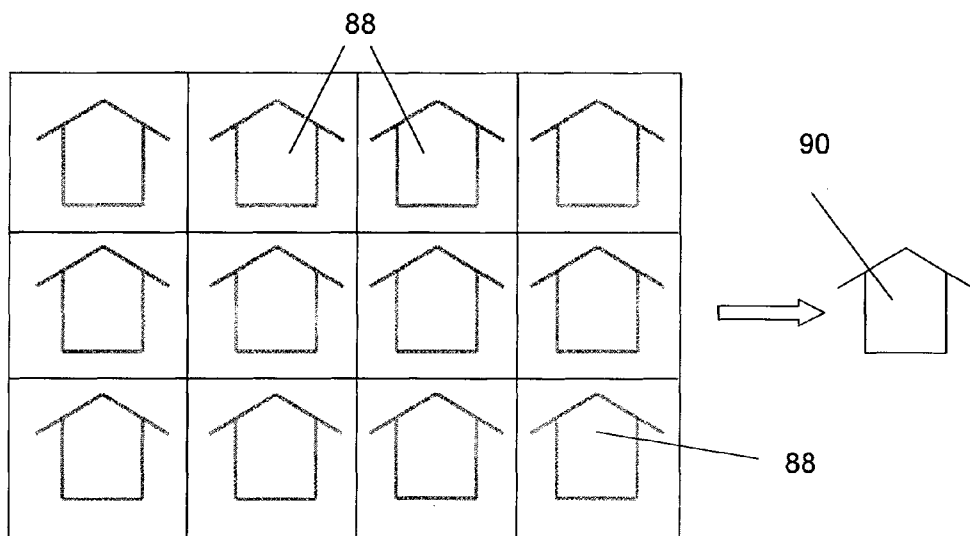

Fig. 2

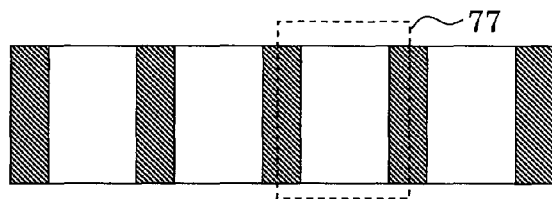

Fig. 14

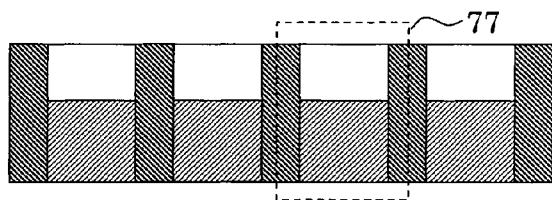

Fig. 15

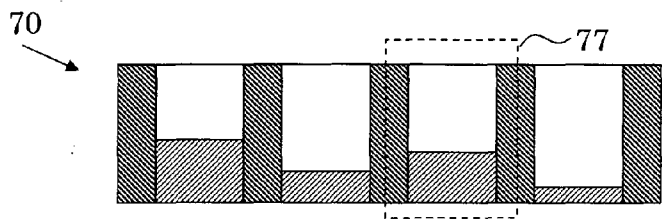
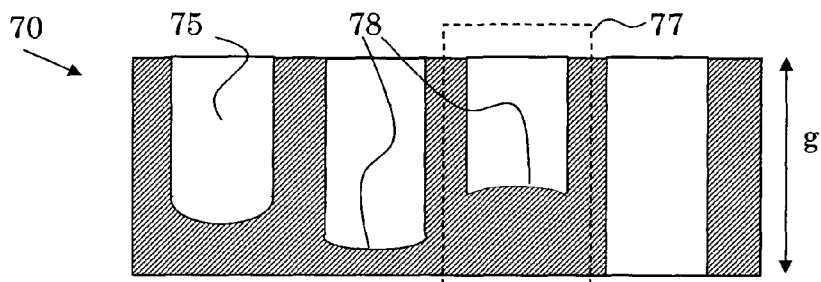
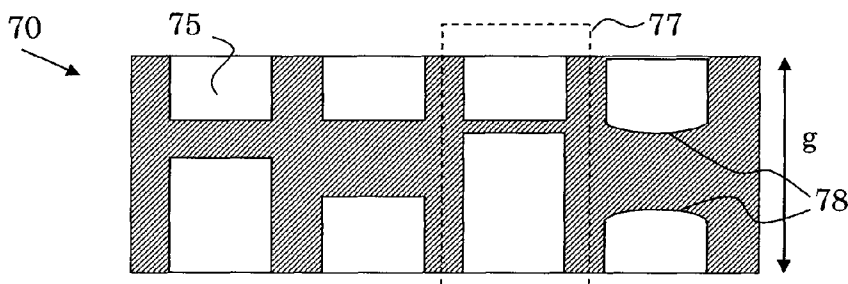

Fig. 16



**Fig. 3**



**Fig. 4**

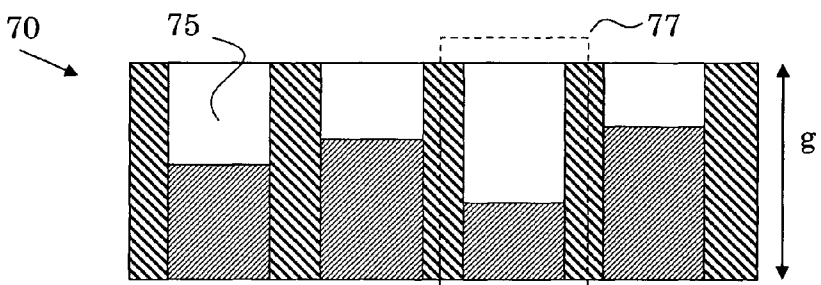

**Fig. 5**

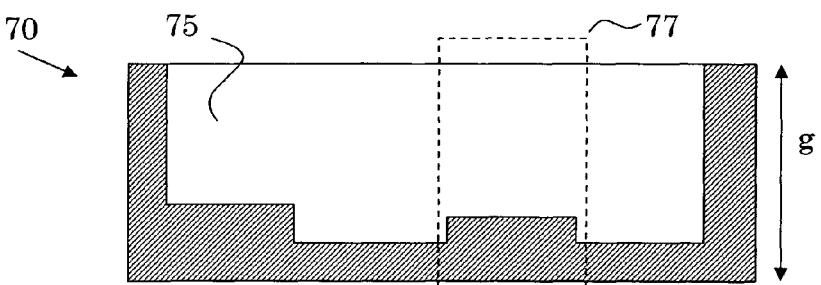

**Fig. 6**

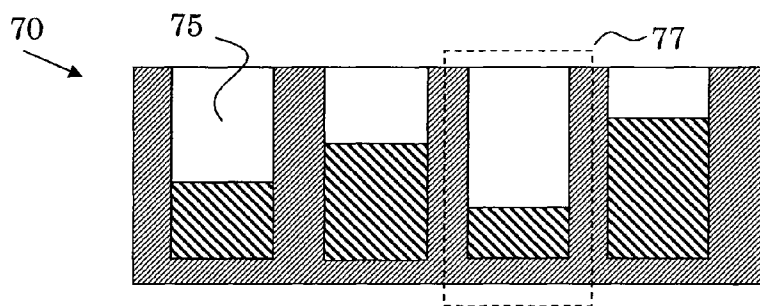

Fig. 7

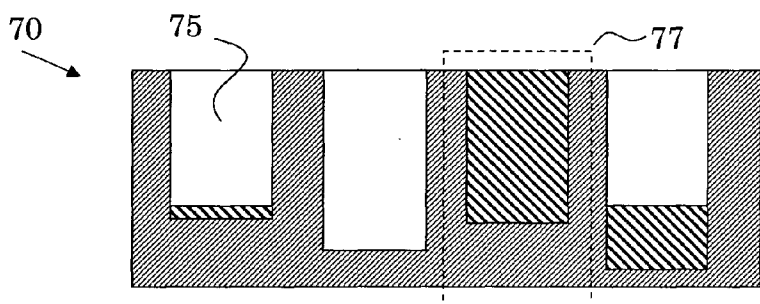

Fig. 8

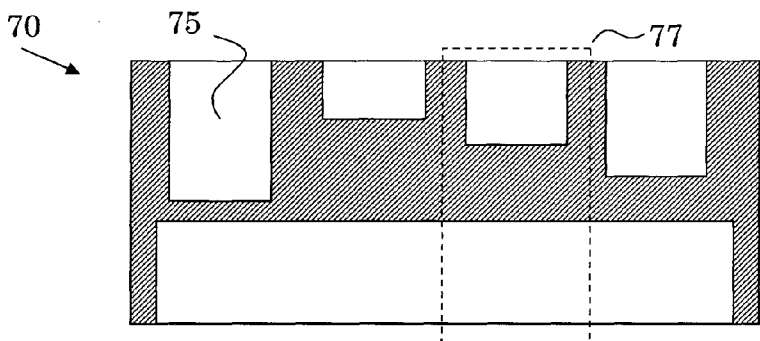

Fig. 9

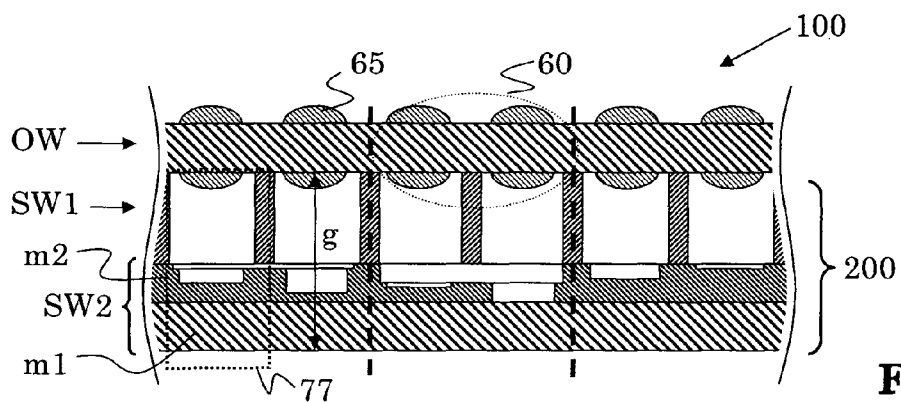

Fig. 13

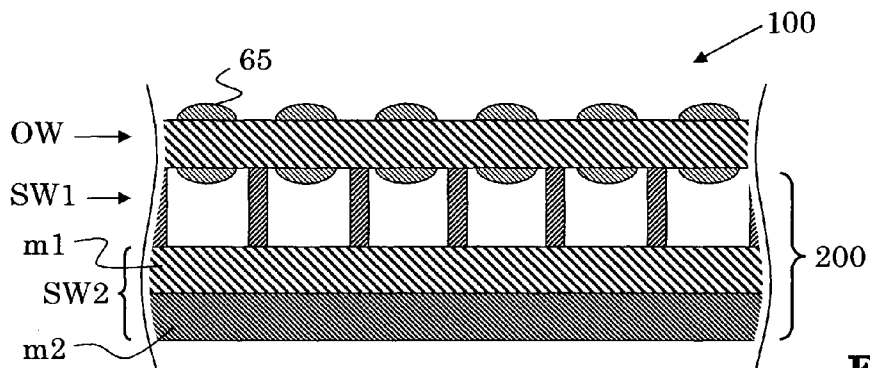

Fig. 10

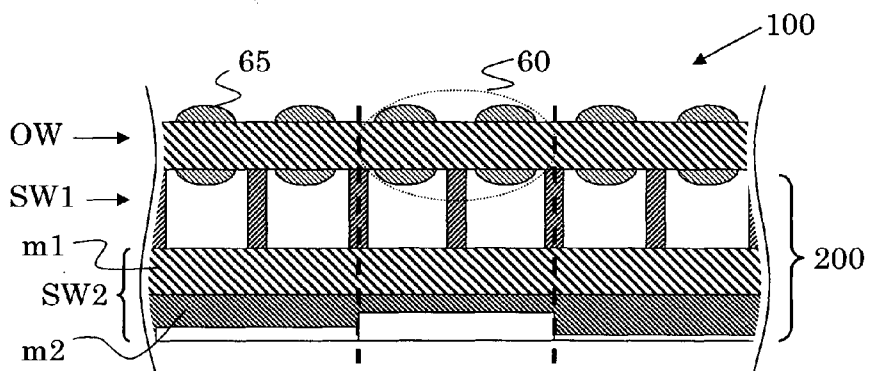

Fig. 11

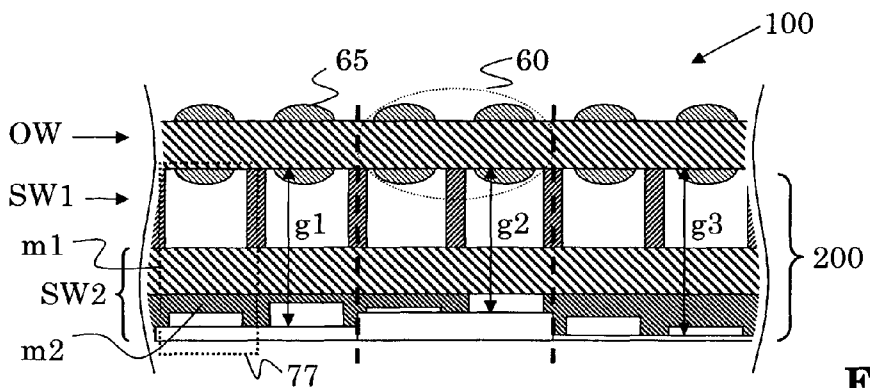

Fig. 12

**WAFER-LEVEL FABRICATION OF OPTICAL  
DEVICES, IN PARTICULAR OF MODULES  
FOR COMPUTATIONAL CAMERAS**

TECHNICAL FIELD

**[0001]** The invention relates to the field of optics, more particularly micro-optics. In particular, it relates to wafer-level fabrication of optical devices such as optical systems, opto-electronic modules and cameras. It relates to methods and apparatuses according to the opening clauses of the claims.

BACKGROUND OF THE INVENTION

**[0002]** From the international patent application published as WO 2011/156928 A2 (filed on Jun. 10, 2011), cameras and optical modules for cameras are known, which can be fabricated on wafer level. Therein, cameras and optical modules for cameras as well as methods for manufacturing the same are disclosed in some detail. Therefore, that patent application WO 2011/156928 A2 is hereby incorporated by reference in the present patent application.

DEFINITION OF TERMS

**[0003]** “Active optical component”: A light sensing or a light emitting component. E.g., a photodiode, an image sensor, an LED, an OLED, a laser chip.

**[0004]** “Passive optical component”: An optical component redirecting light by refraction and/or diffraction and/or reflection such as a lens, a prism, a mirror, or an optical system, wherein an optical system is a collection of such optical components possibly also comprising mechanical elements such as aperture stops, image screens, holders.

**[0005]** “Opto-electronic module”: A component in which at least one active and at least one passive optical component is comprised.

**[0006]** “Replication”: A technique by means of which a given structure or a negative thereof is reproduced. E.g., etching, embossing, imprinting, casting, molding.

**[0007]** “Wafer”: A substantially disk- or plate-like shaped item, its extension in one direction (z-direction or vertical direction) is small with respect to its extension in the other two directions (x- and y-directions or lateral directions). Usually, on a (non-blank) wafer, a plurality of like structures or items are arranged or provided therein, typically on a rectangular grid. A wafer may have opening or holes, and a wafer may even be free of material in a predominant portion of its lateral area. Although in many contexts, a wafer is understood to be prevalingly made of a semiconductor material, in the present patent application, this is explicitly not a limitation. Accordingly, a wafer may prevalingly be made of, e.g., a semiconductor material, a polymer material, a composite material comprising metals and polymers or polymers and glass materials. In particular, hardenable materials such as thermally or UV-curable polymers are interesting wafer materials in conjunction with the presented invention.

**[0008]** “Lateral”: cf. “Wafer”

**[0009]** “Vertical”: cf. “Wafer”

**[0010]** “Light”: Most generally electromagnetic radiation; more particularly electromagnetic radiation of the infrared, visible or ultraviolet portion of the electromagnetic spectrum.

SUMMARY OF THE INVENTION

**[0011]** One object of the invention is to provide an alternative way of manufacturing devices, in particular optical devices, such as optical systems, opto-electronic modules and cameras, and in particular to provide an improved way of manufacturing devices, in particular optical devices, such as optical systems, opto-electronic modules and cameras. Furthermore, corresponding devices, in particular optical devices such as optical systems, opto-electronic modules and cameras, as well as related devices and apparatuses such as wafers and wafer stacks shall be provided.

**[0012]** Another object of the invention is to improve the manufacturing yield in the manufacture of optical devices such as optical systems, opto-electronic modules and cameras.

**[0013]** Another object of the invention is to achieve an improved quality of optical devices such as optical systems, opto-electronic modules and cameras, in particular when these are manufactured on wafer-scale.

**[0014]** Further objects emerge from the description and embodiments below.

**[0015]** At least one of these objects is at least partially achieved by apparatuses and methods according to the patent claims and/or by the below-described apparatuses and methods.

**[0016]** The invention relates in particular to cameras and to modules (in particular opto-electronic modules) for cameras, as well as to constituents thereof and to wafers and wafer stacks used during manufacture of any of these; and it also relates, in particular, to methods of manufacturing cameras and/or modules (in particular opto-electronic modules) for cameras and/or constituents thereof and/or wafers and/or wafer stacks. The manufacture usually involves wafer-scale manufacturing steps.

**[0017]** During the manufacture of devices, in particular optical devices, manufacturing irregularities or manufacturing deviations may occur, e.g., simply, because of more or less unavoidable variations or inaccuracies in one or more of the process steps. E.g., when the device comprises at least one lens element, a multitude of such lens elements on a wafer (referred to as optics wafer), in reality, have (slightly) varying focal lengths despite of having nominally the same focal length.

**[0018]** It has been found that it is possible to at least partially correct or compensate for manufacturing irregularities on wafer level, thus achieving an improved yield and/or improved optical properties of the devices.

**[0019]** A spacer wafer compensating—on wafer level—for such manufacturing irregularities is suggested. Such a spacer wafer usually comprises a multitude ( $M \geq 2$ ,  $M$  being an integer) of spacer members, and it is in particular suggested that each of said multitude of spacer members has  $N \geq 2$  light channels ( $N$  being an integer) having at least substantially the same geometrical length (for light travelling therethrough), but at least two of them presenting mutually different optical path lengths. In particular, therein, said light channels are extending vertically across the spacer member. And in particular, said geometrical length is a length along a vertical direction and/or said geometrical length is a length across the spacer member.

**[0020]** Typically, said  $N$  light channels are arranged in form of an array.

[0021] In particular, the following embodiments can, at least in a specific view or aspect of the invention, be characteristic for the invention:

[0022] A Device:

[0023] The device comprises an optics member and a spacer member, said optics member comprising  $N \geq 2$  sets of passive optical components comprising one or more passive optical components each, said spacer member comprising  $N$  light channels, each of said  $N$  light channels being associated with one of said  $N$  sets of passive optical components. All of said  $N$  light channels have an at least substantially identical geometrical length, and an optical path length of a first of said  $N$  light channels is different from an optical path length of at least one second of said  $N$  light channels.

[0024] In one embodiment, said spacer member is structured in such a way that all of said  $N$  light channels have an at least substantially identical geometrical length and that an optical path length of a first of said  $N$  light channels is different from an optical path length of at least one second of said  $N$  light channels, in particular wherein said spacer member is shaped in said way.

[0025] In one embodiment which may be combined with the before-addressed embodiment, for each of said  $N$  light channels, said optical path length has a value related to and/or is chosen in dependence of manufacturing irregularities of the respective associated optics member, in particular manufacturing irregularities of the passive optical components of the set of passive optical components of the respective associated optics member.

[0026] In one embodiment referring to the last-addressed embodiment, said optics member comprises at least one lens element, said manufacturing irregularities comprising a deviation of a characteristic magnitude of said at least one lens element from a nominal value. In particular, said nominal value can be a focal length of said at least one lens element.

[0027] In one embodiment of the device which may be combined with one or more of the before-addressed embodiments, at least one of said  $N$  light channels comprises a blind hole in said spacer member. In particular, said at least one blind hole can be provided for contributing to achieving said difference in optical path length between said at least a first one of said  $N$  light channels and at least a second one of the light channels. In particular, it can be provided that for each of these at least two light channels, a length of the respective blind hole is related to the optical path length of the respective light channel, more particularly wherein a length of said first of said at least two blind holes is different from a length of said second one of said at least two blind holes.

[0028] In one embodiment which may be combined with one or more of the before-addressed embodiments, said spacer member comprises a first layer and a second layer which are made of mutually different materials, in particular wherein said second layer is made of a polymer material and/or said first layer is made of a different polymer material or of glass. Said layers can in particular form a generally laterally extended interface (at which they are bonded with respect to each other). They may be in particular be substantially block-shaped or plate-shaped. Said layers can also be considered to be spacers.

[0029] It can in particular be provided that a vertical extension of said second layer in each of said light channels is related to or selected in dependence of manufacturing irregularities of the respective associated optics member. And it

may furthermore be provided that a vertical extension of said first layer is substantially identical for each of said regions.

[0030] In one embodiment which may be combined with one or more of the before-addressed embodiments, said spacer member comprises channel walls (laterally) surrounding each of said  $N$  light channels, wherein in one or more of said  $N$  light channels, in particular in each of said  $N$  light channels, a transparent material is present. An amount of said transparent material present in a first of said  $N$  light channels is different from an amount of said transparent material present in a second one of said  $N$  light channels. Those amounts can be chosen for a sought compensation of manufacturing irregularities. It can be provided that the channel walls are non-transparent, and in particular that they are made of a non-transparent material. It is possible to manufacture wafers by replication which comprise a multitude of such channel walls surrounding openings; such a wafer can, e.g., be shaped like a flat sieve with prismatic or tubular openings. It can furthermore be provided that said transparent material is a hardened hardenable material. This way, it can be filled into the channels in liquid form and hardened afterwards. The transparent material present in one of said  $N$  light channels may in particular fill the respective channel completely along a vertically defined range, in particular wherein said vertically defined range ends at an end of said respective channel.

[0031] In one embodiment which may be combined with one or more of the before-addressed embodiments, each of said  $N$  sets of passive optical components has a characteristic magnitude, said characteristic magnitude being nominally identical for all of said  $N$  sets of passive optical components. Said characteristic magnitude may, e.g., be a focal length. And it may be provided that said differences in said optical path lengths are provided for at least partially compensating for undesired differences in said characteristic magnitude between two or more of said  $N$  sets of passive optical components. Said undesired differences may in particular be due to manufacturing irregularities. This may be particularly useful when said passive optical components are manufactured using replication. In replication processes, manufacturing irregularities are likely to occur which are repeatable, i.e. which occur identically or close to identically when repeatedly carrying out the replication process.

[0032] In one embodiment which may be combined with one or more of the before-addressed embodiments, said optics member is manufactured using replication, in particular wherein, for at least one of said  $N$  sets (more particularly for each of said  $N$  sets), at least one of said one or more passive optical components is manufactured using replication. More specifically, it can be provided that for each of said  $N$  sets, all of said one or more passive optical components are manufactured using replication.

[0033] In one embodiment which may be combined with one or more of the before-addressed embodiments, the device comprises a member referred to as detection member, said detection member comprising  $N$  active optical components, each of said  $N$  active optical components being associated with one of said  $N$  sets of passive optical components, in particular wherein each of said  $N$  active optical components is a light-sensing component. Said spacer member can in particular be arranged between said detection member and said optics member. Such a device can in particular be a device for capturing  $N$  sub-images, one by means of one of said  $N$  active optical components each. And typically, said sub-images are sub-images to be processed to yield a full image. For this

purpose, the device may comprise a microprocessor operationally connected to each of said N active optical components. Said microprocessor can in particular be configured for processing said N sub-images, more specifically for generating a full image from said N sub-images. Said microprocessor may be, e.g., comprised in said detection member.

**[0034]** An Appliance, in a First Aspect:

**[0035]** The appliance comprises, in a first aspect, a multitude of devices as described in the present patent application. In particular, said appliance may comprise at least one wafer comprising  $M \geq 2$  devices as described in the present patent application. Such an appliance may in particular be a wafer or a wafer stack.

**[0036]** An Appliance, in a Second Aspect:

**[0037]** The appliance comprises, in a second aspect, a wafer referred to as spacer wafer, said spacer wafer comprising  $M \geq 2$  spacer members, each of said spacer members comprising  $N \geq 2$  light channels, wherein for each of said spacer members applies that all of the respective N light channels have an at least substantially identical geometrical length and an optical path length of a first of the respective N light channels is different from an optical path length of at least one second of said respective N light channels, wherein M is an integer and N is an integer. Such an appliance may in particular be a wafer or a wafer stack.

**[0038]** In one embodiment of the appliance, said geometrical length of a first one of said M spacer members is different from said geometrical length of at least a second one of said M spacer members. Alternatively, said geometrical length can be (at least nominally) equal for all of said M spacer members.

**[0039]** In one embodiment which may be combined with the before-addressed embodiment, said spacer wafer comprises a first layer and a second layer which are made of mutually different materials, in particular wherein a vertical extension (or thickness) of said first layer is substantially identical for each of said regions. Said layers may, in particular, be substantially plate-shaped. They may also be considered wafers.

**[0040]** In one embodiment which may be combined with one or more of the before-addressed embodiments, the appliance comprises a wafer referred to as optics wafer, said optics wafer comprising M optics members comprising N sets of passive optical components each, each of said N sets of passive optical components comprising one or more passive optical components. In particular, said spacer wafer and said optics wafer may be comprised in a wafer stack and/or each of said M optics members is associated with a different one of said M spacer members.

**[0041]** The invention comprises appliances with features of corresponding devices according to the invention, and, vice versa, also devices with features of corresponding appliances according to the invention.

**[0042]** The advantages of the devices basically correspond to the advantages of corresponding appliances, and, vice versa, the advantages of the appliances basically correspond to the advantages of corresponding devices.

**[0043]** Furthermore, it is also possible to combine the first and second aspects of the appliances.

**[0044]** A Method, in a First Specific View:

**[0045]** In a first specific view, the method for manufacturing a device as described in the present patent application comprises the step of providing a spacer wafer comprising  $M \geq 2$  of said spacer members, wherein M is an integer. In particular, the method comprises the step of manufacturing

said spacer wafer. The wafer-level manufacture can be particularly well suitable for manufacturing the devices and may allow to manufacture to tight tolerances (dimensionally and optically) at a high yield.

**[0046]** In one embodiment, the method comprises the step manufacturing said spacer wafer using cutting and/or machining and/or drilling and/or laser ablation, in particular wherein a plurality of blind holes is created in said spacer wafer by means of said cutting and/or machining and/or drilling and/or laser ablation, more particularly wherein said plurality of blind holes are not all of the same length. This can be an efficient way of realizing various different optical path lengths while having the same geometrical path length all light channels.

**[0047]** In one embodiment which may be combined with one or more of the before-addressed embodiments, the method comprises manufacturing said spacer wafer, said manufacturing said spacer wafer comprising the steps of

**[0048]** providing a wafer;

**[0049]** locally decreasing a vertical extension of said wafer;

wherein said locally decreasing a vertical extension of said wafer comprises carrying out a first processing step and carrying out subsequently to said first processing step a second processing step different from said first processing step. More particularly, it can be provided that said first processing step differs from said second processing step in at least one of

**[0050]** an applied processing technique;

**[0051]** a tool used in the respective processing step;

**[0052]** at least one processing parameter used in the respective processing step.

**[0053]** It can also be provided that said first processing step is carried out at a higher rate of removal of material from said plurality of said multitude of regions than said second processing step.

**[0054]** In one embodiment referring to the last-addressed embodiment, said first processing step is carried out simultaneously for all light channels of a spacer member, and said second processing step is carried out separately for different light channels of a spacer member.

**[0055]** In one embodiment which may be combined with the before-addressed embodiment, the method comprises the steps of

**[0056]** providing a wafer having a multitude of holes, one for each of said light channels, in particular wherein said holes are through-holes;

**[0057]** filling a hardenable material in liquid state into said holes;

**[0058]** hardening said hardenable material in said holes; wherein said hardenable material is transparent, at least when hardened.

**[0059]** In one embodiment which may be combined with one or more of the before-addressed embodiments, spacer wafer comprises a first layer and a second layer which are made of mutually different materials, in particular wherein the method comprises removing material from said second layer, more particularly wherein said second layer is made of a polymer material. The removal of material can more specifically serve to adjusting optical path lengths in the light channels. It can furthermore be provided that no material is removed from said first layer, in particular not for adjusting optical path lengths of the light channels. Said first and second layers may form two mutually adhering plates

**[0060]** The invention comprises methods with features of corresponding devices or appliances according to the invention, and, vice versa, also devices and appliances with features of corresponding methods according to the invention.

**[0061]** The advantages of the methods basically correspond to the advantages of corresponding devices and appliances, respectively, and, vice versa, the advantages of the devices and appliances, respectively, basically correspond to the advantages of corresponding methods.

**[0062]** A Method, in a Second Specific View:

**[0063]** In a second specific view, the method is a method for manufacturing a device, in particular wherein said device is a camera or an opto-electronic module for a camera, said method comprising the step of

**[0064]** providing, in particular manufacturing, a spacer wafer comprising  $M \geq 2$  spacer members, wherein  $M$  is an integer, each of said  $M$  spacer members comprising  $N \geq 2$  light channels,  $N$  being an integer;

**[0065]** providing, in particular manufacturing, an optics wafer comprising  $M$  optics members, each of said  $M$  optics members comprising  $N$  sets of passive optical components comprising one or more passive optical components each;

**[0066]** providing, in particular manufacturing, a detection wafer comprising  $M$  detection members, each of said  $M$  detection members comprising  $N$  active optical components each;

wherein each of said  $M$  spacer members is associated with a different one of said optics members and associated with a different one of said detection members, and wherein for each of said  $M$  spacer members, each of the respective  $N$  spacer members is associated with a different one of the  $N$  sets of active optical components of the associated optics member and associated with a different one of the  $N$  active optical components of the associated detection members, and

wherein for at least one, more particularly for a plurality, of said  $M$  spacer members and the associated optics members and the associated detection members applies that

**[0067]** all of the  $N$  light channels of a respective spacer members provide an at least substantially identical geometrical path length for light travelling from the associated set of passive optical components of the associated optics member through the respective light channel to the associated active optical component of the associated detection member, and

**[0068]** an optical path length for light travelling from a first of the  $N$  sets of passive optical components of a respective optics member through the associated light channel to the associated active optical component is different from an optical path length for light travelling from a second of said  $N$  sets of passive optical components of that respective optics member through the respective associated light channel to the respective associated active optical component.

**[0069]** In one embodiment, the method comprises the step of manufacturing said spacer wafer using a replication step, in particular wherein a replication master used in said replication step is designed for accomplishing said differences in optical path lengths of light channels and, optionally, wherein a so-obtained spacer member already designed for accomplishing said different optical path lengths of light channels is subjected to a further processing step for achieving an increased precision of optical path lengths of light channels of

a so-obtained further processed spacer member. It can in particular be provided that said further processing step comprises adding material to the spacer member and/or removing material from the spacer member, more particularly wherein said further processing step comprises cutting and/or machining and/or drilling and/or a laser ablation step. It can be provided that a length of one or more blind holes in said spacer wafer is increased by means of said cutting and/or machining and/or drilling and/or laser ablation.

**[0070]** In one embodiment which may be combined with one or more of the before-addressed embodiments, the method comprises manufacturing said spacer wafer, said manufacturing said spacer wafer comprising the steps of

**[0071]** providing a wafer;

**[0072]** locally decreasing a vertical extension of said wafer;

wherein said locally decreasing a vertical extension of said wafer comprises carrying out a first processing step and carrying out subsequently to said first processing step a second processing step different from said first processing step.

**[0073]** The invention comprises methods with features of corresponding devices or appliances according to the invention, and, vice versa, also devices and appliances with features of corresponding methods according to the invention.

**[0074]** The advantages of the methods basically correspond to the advantages of corresponding devices and appliances, respectively, and, vice versa, the advantages of the devices and appliances, respectively, basically correspond to the advantages of corresponding methods.

**[0075]** Furthermore, it is also possible to combine methods in said first and second views.

**[0076]** Further embodiments and advantages emerge from the claims and the figures.

BRIEF DESCRIPTION OF THE DRAWINGS

**[0077]** Below, the invention is described in more detail by means of examples and the included drawings. The figures show in a strongly schematized manner:

**[0078]** FIG. 1 an exploded view of a device, in a cross-sectional view;

**[0079]** FIG. 2 an illustration that from a number of sub-images, a full image can be obtained;

**[0080]** FIG. 3 a spacer member with lens shapes, in a cross-sectional view;

**[0081]** FIG. 4 a spacer member with lens shapes, in a cross-sectional view;

**[0082]** FIG. 5 a spacer member with non-transparently surrounded light channels, in a cross-sectional view;

**[0083]** FIG. 6 a spacer member with not-separated light channels, in a cross-sectional view;

**[0084]** FIG. 7 a spacer member, in a cross-sectional view;

**[0085]** FIG. 8 a spacer member, in a cross-sectional view;

**[0086]** FIG. 9 a spacer member, in a cross-sectional view;

**[0087]** FIG. 10 a detail of a wafer stack comprising spacer members comprising more than one unitary parts, in a cross-sectional view;

**[0088]** FIG. 11 a detail of the wafer stack of FIG. 10 after a first processing step, in a cross-sectional view;

**[0089]** FIG. 12 a detail of the wafer stack of FIGS. 10 and 11 after a second processing step, in a cross-sectional view;

**[0090]** FIG. 13 a detail of a wafer stack comprising a two-times processed spacer member comprising more than one unitary parts, in a cross-sectional view;

[0091] FIG. 14 a member of non-transparent material comprising through-holes as light channels, in a cross-sectional view;

[0092] FIG. 15 the member of FIG. 14, with transparent material filled in the light channels, in a cross-sectional view;

[0093] FIG. 16 the member of FIG. 14, with different amounts of transparent material filled in the light channels, in a cross-sectional view.

[0094] The described embodiments are meant as examples and shall not confine the invention.

#### DETAILED DESCRIPTION OF THE INVENTION

[0095] FIG. 1 is a schematic illustration of an aspect of the invention, in a cross-sectional view. It shows, in an exploded view, three members, namely an optics member 60, a spacer member 70 and a detection member 80, which form together a device 50, more particularly an opto-electronic module 50.

[0096] Optics member 60 comprises several passive optical components 65, in particular lenses 65. Passive optical components 65 have assigned nominal focal lengths, in particular all have the same nominal focal length. But—usually for manufacturing reasons—the focal lengths of the passive optical components 65 (more particularly: front focal lengths) deviate from their respective nominal focal length, as shown in FIG. 1 by the arrows referenced f.

[0097] Detection member 80 can in particular be a semiconductor chip comprising active optical components 85 such as image sensors 85.

[0098] Spacer member 70 contributes to ensuring a pre-defined distance cf. reference “g” in FIG. 1) between member 60 and member 80. But, moreover, it also contributes to an at least partial correction of the above-described deviations from the nominal focal lengths. Spacer member 70 comprises several light channels 77, one per each passive optical component 65. Each of the light channels 77 comprises a blind hole 75 and a portion of transparent material 76.

[0099] The index of refraction of the material of spacer member 70 is different from (usually greater than) the index of refraction of vacuum or air which is usually present in the blind holes 75. Thus, by adjusting the lengths of the blind holes 75 in dependence of the deviations of the focal length of the associated passive optical component 65 from the respective nominal focal lengths, deviations can be compensated, at least to some degree. The geometrical length g is (at least nominally) identical for each of the light channels 77; it corresponds to a (maximum or overall) vertical extension of spacer member 70.

[0100] Therefore, the lengths of the blind holes are different for differently deviating passive optical components 65.

[0101] This way, it can be achieved that an imaging taking place using the different passive optical components 65 with their different focal lengths results in the (nominally) desired imaging. And thus, each active optical component 85 of member 80, e.g., detecting elements 85 such as image sensors 85, can record the desired image; without the individually chosen or adjusted blind holes, the recorded images would deviate or differ from the desired images, usually to an extent depending on the amount of manufacturing irregularities of the respective passive optical components 65. In particular, each active optical component 85 records one sub-image, e.g., one plenoptic camera sub-image or one array camera sub-image, or one sub-image for one color or wavelength range, wherein in that case not all active optical components 85 record sub-images for the same color or wavelength range.

[0102] The sub-images taken by the different active optical components 85 can be processed so as to derive from them a full (final) image.

[0103] FIG. 2 illustrates that from a number of such sub-images 88, a full image 90 can be obtained.

[0104] There are also other possibilities to achieve a variation in optical path length between the different light channels 77 despite of them having the same geometrical path length g, see, e.g., the patent claims. E.g., shapes such as lens-shapes can be produced in the optical paths, e.g., in the blind holes. FIGS. 3 and 4 show, in a cross-sectional view, a spacer member 70 with blind holes having a curved (lens-shaped) bottom 78. In other words, lens elements are formed in the light channels. In FIG. 3, it is also illustrated that a light channel may comprise a through-hole (cf. the right-most channel in FIG. 3). In FIG. 4, it is also illustrated that material can be removed from both sides of the spacer member 70, i.e. from the object side (generally in all the Figures showing a spacer member meant to be towards the top of the drawing page, like in FIG. 1) at which an optics member will usually be located, and at the detector side (generally in all the Figures showing a spacer member meant to be towards the bottom of the drawing page, like in FIG. 1), at which a detection member will usually be located. Generally, spacer members illustrated in one of the Figures of the present patent application may be used as a spacer member in devices like the one illustrated in FIG. 1, replacing the spacer member shown there.

[0105] The light channels 77 may be separate from each other, in particular optically separate from each other. E.g., a portion of the spacer member may be made of a non-transparent material, in particular such that each light channel 77 is at least partially surrounded by non-transparent material. FIG. 5 illustrates a spacer member 70 with non-transparently surrounded light channels 77, in a cross-sectional view. The outer portion of each light channel 77 is made of a non-transparent material, e.g., of a hardened hardenable material such as a curable epoxy resin, whereas the inner portion is filled with a transparent material such as, again, a hardened hardenable material such as a curable epoxy resin, wherein said filling fills the respective light channel (i.e. in the illustrated case, the respective through-hole in spacer member 70) laterally completely, but (generally for at least one of the light channels) vertically only in part. A lateral cross-section through a light channel can be, e.g., circular or rectangular (with sharp or with rounded corners).

[0106] But it is also possible to provide that at least one of the light channels 77 is adjacent to at least one other light channels of the spacer member or is even partially overlapping with at least one other light channels of the spacer member. FIG. 6 illustrates a spacer member 70 with not-separated light channels, in a cross-sectional view.

[0107] A possible advantage of optically separated light channels, cf., e.g., FIG. 5, is the possibility to suppress crosstalk between the light channels. A possible advantage of not-separated light channels is that a corresponding device can be (laterally) smaller, passive optical components (cf. FIG. 1) can be closer to each other, and detection members (cf. FIG. 1) can be closer to each other.

[0108] FIG. 7 illustrates another spacer member 70, in a cross-sectional view. This is to illustrate that one can also fill liquid material into a blind-hole. Also this filled-in material may be hardened. The amount of filled-in material can be selected such that a sought compensation of manufacturing irregularities is achieved.

[0109] FIG. 8 illustrates another spacer member 70, in a cross-sectional view. This is to illustrate that one can prepare, e.g., by means of replication, a wafer (or member) already implementing a compensation for manufacturing irregularities of an optics member. And furthermore, it illustrates that it is possible, in addition, to then fill liquid material into the blind-holes for fine-tuning the compensation.

[0110] FIG. 9 illustrates another spacer member 70, in a cross-sectional view. This is to illustrate on the one hand that it is possible to carry out corrections/adjustments that (simultaneously) apply to all channels of a spacer member 70, and on the other hand that the detector side of a spacer member 70 does not necessarily have to describe a single plane (cf. also FIG. 4). But, it can be advantageous to provide that the detector side of a spacer member 70 describes a single plane (as is illustrated in most Figures of the present patent application), because in that case, the spacer member can be readily bonded to a detection member (cf. FIG. 1) without providing additional interfaces (between air and a higher refractive index material such as material of the spacer member or of the detection member), which again can result in less reflection losses and in a higher imaging quality.

[0111] The general function of a device 50 (cf. FIG. 1) is that light impinging from an object side (above member 60 in FIG. 1) is imaged by passive optical components 65 through light channels 77 onto the active optical components 85 of member 80.

[0112] Devices 50 can be used, e.g., in a communication device and/or in a camera such as in an array camera.

[0113] It is suggested to manufacture any of, in particular all of the members 60, 70, 80 in form of wafers each comprising a multitude of the respective members. This can make the manufacture of the device 50 very efficient, including simplifying accomplishing the individual adjustments suggested for the compensating for of the manufacturing irregularities.

[0114] E.g., the focal length of each of the passive optical components 65 is determined, and, in dependence of the result thereof, the blind holes are created (e.g., by drilling and/or laser ablation) having the appropriate length (cf., e.g., FIGS. 1, 3, 4, 6, 9, which can be interpreted accordingly); or a suitable spacer wafer is produced using replication already taking into account—by using a suitable replication master—the manufacturing irregularities to be compensated for (cf., e.g., FIGS. 1, 3, 6, 9, which can be interpreted accordingly).

[0115] It is also possible to combine these two approaches by using a suitable spacer wafer already compensating to some extent for the manufacturing irregularities, e.g., by having blind holes of corresponding lengths, and then to apply further corrections, such as by changing the optical path length through light channels by means of which a sufficient compensation of the respective manufacturing irregularities has not yet been achieved (cf., e.g., FIGS. 3, 4, 8, 9, which can be interpreted accordingly). These further corrections can be accomplished, e.g., by drilling and/or machining and/or cutting and/or laser ablation.

[0116] FIGS. 10 to 12 illustrate further possible aspects and embodiments of the invention. FIGS. 10 to 12 illustrate, in a cross-sectional view, a wafer stack 100 comprising an optics wafer OW comprising passive optical components 65 at least a portion of which have manufacturing irregularities such as focal lengths deviating from a nominal value, and, attached thereto, a spacer wafer stack 200. Optics wafer OW comprises a multitude of optics members 60, and spacer wafer

stack 200 comprises a multitude of spacer members, wherein in wafer stack 100, each optics member is associated and aligned with a different one of the spacer members. Detection members and a detection wafer are not illustrated in FIGS. 10 to 12.

[0117] Spacer wafer stack 200 comprises a spacer wafer SW1 and a spacer wafer SW2. Spacer wafer SW1 is made of a non-transparent material and can thus strongly contribute to optically mutually isolating light channels 77. Spacer wafer SW1 can furthermore be provided for ensuring a desired (vertical) distance between optics wafer OW and spacer wafer SW2. One particularity of wafer stack 200 is that spacer wafer SW2 comprises two layers m1, m2 of different (but transparent) materials. E.g., layer m1 is made of glass, and layer m2 is made of a polymer material, or layer m1 is made of a polymer material, and layer m2 is made of glass. It can, more generally, be provided that the layer (m1) facing optics wafer OW is provided for providing mechanical stability, whereas the other layer (m2) (more particular, the material of which it is made) is mechanically less stable than (the material of) layer m1. And/or, it can be provided that, considering a method or process for removing material from spacer wafer SW2, the material of layer m2 is easier to remove than the material of layer m1. It is to be noted, however, that layer m1 can, in general, also be dispensed with.

[0118] It is furthermore generally possible to consider layers m1 and m2, respectively, as distinct spacer wafers which, however, are bonded to each other.

[0119] More specifically, as illustrated in FIGS. 11 and 12, it is possible to provide that a removal of material for compensating for manufacturing irregularities of optics wafer OW takes place in layer m2 only.

[0120] Furthermore, FIGS. 10 to 12, and more specifically, FIGS. 11 and 12, illustrate that it is possible to carry out a removal of material from a spacer wafer or from a spacer wafer stack 200 (or, more specifically from a layer m2) in two (or generally: two or more) processing steps. Removing material can allow to change the optical path length in light channels 77. In this case, FIG. 11 illustrates the wafer stack resulting from applying a first processing step to spacer wafer stack 200 of FIG. 10, and FIG. 12 illustrates the wafer stack 100 resulting from applying a second processing step to spacer wafer stack 200 of FIG. 11. The two successively applied processing steps can be different processing steps, e.g., if both processing steps are carried out by means of milling, in the first processing step, a different milling tool may be used and possibly also a faster feed rate than in the second processing step may be applied. And it is also possible to combine different processing techniques in the processing steps, e.g., laser ablation first, and milling thereafter, or vice versa.

[0121] The second processing step may in particular be a fine-tuning step (for optimizing the compensation effect).

[0122] And even further, FIGS. 11 and 12 may be looked upon as illustrating a possible way of proceeding in case of multi-channel devices, such as four-channel devices with a 2x2 array of channels (cf. FIGS. 11 and 12). As illustrated in FIG. 11, it is possible to carry out the first processing step individually for one device, i.e. for one spacer member, but carry out the second processing step individually for each light channel 77 (cf. FIG. 12). Thus, after a separation step (cf. the thick dashed lines in FIG. 12), spacer members will usually be obtained which have different heights (vertical extensions) and thus different geometrical lengths g1, g2, g3 of

their light channels, which, however, are equal for all light channels of one spacer member, but corrections for, e.g., focal lengths, can be made (in the second processing step) individually for each channel.

**[0123]** In an embodiment like the one of FIGS. 10 to 12, bonding of detection members to the spacer members will usually have to take place after separation of spacer wafer 200 which may be accomplished during separating wafer stack 100.

**[0124]** FIG. 13 illustrates a two-times processed spacer member comprising more than one unitary parts (SW1, m1, m2), in a cross-sectional view. In fact, FIG. 13 very much corresponds to FIG. 12, but spacer wafer SW2 is horizontally (laterally) mirrored, and, in addition, the (laterally defined) area in which material is removed in the second processing step is reduced with respect to what is illustrated in FIG. 12.

**[0125]** In case of an embodiment like illustrated in FIG. 13, data would be obtained on manufacturing irregularities of passive optical components 65, or, in particular, of sets of passive optical components composed of the passive optical components belonging to one and the same light channel. Based on such data, layer m2 of spacer wafer SW2 would be subjected to a first processing step (similar to what is illustrated in FIG. 11). This first processing step would in particular be applied simultaneously to all light channels of a spacer member (and typically using one and the same tool), but separately for different spacer members.

**[0126]** Thereafter, possibly based on further data on manufacturing irregularities of passive optical components 65 (possibly obtained from a preliminary assembly of optics wafer OW, spacer wafer SW1 and spacer wafer SW2), a second processing step is applied, in which each light channel is individually addressed.

**[0127]** Then, spacer wafers SW1 and SW2 and optics wafer OW are bonded together so as to form a wafer stack 100. This may be accomplished in one or more steps. It is also possible that a detection wafer comprising a multitude of detection members (cf. FIG. 1) is bonded to spacer wafer SW2 already at this point—or this is accomplished thereafter. Finally, a separation step is applied in which separate devices are obtained, e.g., by dicing or laser cutting. A so-obtained device can be, e.g., a computational camera or a module for a computational camera, or an array camera or a module for an array camera.

**[0128]** FIGS. 14 to 16 illustrate, in a cross-sectional view, a spacer member with non-transparently (laterally) encompassed light channels 77. The embodiment of FIG. 5 is similar thereto and, in fact, FIGS. 14 to 16 allow to illustrate ways of obtaining a spacer wafer as illustrated in FIG. 5.

**[0129]** FIG. 14 illustrates a member of non-transparent material comprising through-holes as light channels, in a cross-sectional view; FIG. 15 illustrates, in a cross-sectional view, the member of FIG. 14, but with transparent material filled in the light channels; and FIG. 16 illustrates the member of FIG. 14, with different amounts of transparent material filled in the light channels, in a cross-sectional view.

**[0130]** For obtaining a spacer member 70 like illustrated in FIGS. 5 and 16, a wafer comprising a multitude of through-holes (cf. FIG. 14) may be provided. Such a wafer can be obtained, e.g., as a unitary part, e.g., using a replication process. Then, a liquid hardenable material is filled into the through holes and is thereafter hardened, e.g., cured. During this, said wafer can be placed on a substrate such as on a mat of a silicone in order to avoid liquid material flowing out of

the through-holes. After hardening, the filled-in material is transparent. Possibly, a polishing step may be applied to the so-obtained wafer, in order to have a high-quality optical surface at the detector side.

**[0131]** In a first way of obtaining a spacer member 70 like illustrated in FIGS. 5 and 16, the amount of liquid material filled in the holes is selected individually for each light channel, so as to accomplish the desired adjustment of optical path lengths. In a second way, the amount of material filled in is (at least nominally) equal for all through-holes (i.e. for all light channels) of a spacer member, wherein it can be (at least nominally) equal for all through-holes (i.e. for all light channels) of a spacer wafer (cf.—FIG. 15). After hardening, then, a processing step is carried out, for adding more of a (or of the same) liquid hardenable material individually for the light channels and/or for removing a portion of said liquid hardenable material individually for the light channels. Such a fine-tuning step, however, can also be applied in case of the before-addressed first way.

**[0132]** For filling-in liquid material, e.g., a dispenser (like known from electronics manufacturing for underfilling flip chips and the like) may be used. For removing material, machining or milling or drilling or laser ablation may be used.

**[0133]** As will have become clear from the above, the invention may allow to mass produce high-precision optical devices on wafer scale at a very high yield. In particular if replication is used during (or for) manufacturing optics wafers and/or optics members and/or passive optical components, in particular when a replication step is used for manufacturing simultaneously (or in a single process) a multitude of optics members and/or of passive optical components, repeatable manufacturing irregularities may occur which can very well be compensated for by means of the invention. Therein, replication may or may not be applied for accomplishing said compensation, e.g., for producing a compensating spacer wafer or compensating spacer members.

1.-89. (canceled)

**90.** A device comprising an optics member and a spacer member, said optics member comprising  $N \geq 2$  sets of passive optical components comprising one or more passive optical components each, said spacer member comprising  $N$  light channels, each of said  $N$  light channels being associated with one of said  $N$  sets of passive optical components, wherein all of said  $N$  light channels have an at least substantially identical geometrical length, and wherein an optical path length of a first of said  $N$  light channels is different from an optical path length of at least one second of said  $N$  light channels, wherein said spacer member comprises a first layer and a second layer which are made of mutually different materials.

**91.** The device according to claim 90, wherein a vertical extension of said second layer in each of said light channels is related to manufacturing irregularities of the respective associated optics member.

**92.** The device according to claim 90, wherein a vertical extension of said second layer in each of said light channels is selected in dependence of manufacturing irregularities of the respective associated optics member.

**93.** The device according to claim 90, wherein said second layer is made of a polymer material.

**94.** The device according to claim 93, wherein said first layer is made of a different polymer material.

**95.** The device according to claim 90, wherein first layer is made of glass.

**96.** The device according to claim **90**, wherein said first layer and said second layer form a generally laterally extended interface.

**97.** The device according to claim **96**, wherein said first layer and said second layer are bonded with respect to each other at said generally laterally extended interface.

**98.** The device according to claim **90**, wherein said first layer and said second layer are substantially block-shaped or plate-shaped.

**99.** The device according to claim **90**, wherein a vertical extension of said first layer is substantially identical for each of said light channels.

**100.** The device according to claim **90**, wherein said first and second layers form two mutually adhering plates.

**101.** The device according to claim **90**, wherein said spacer member is fixed with respect to said optics member.

**102.** The device according to claim **90**, wherein said spacer member is shaped in such a way that all of said  $N$  light channels have an at least substantially identical geometrical length and that an optical path length of a first of said  $N$  light channels is different from an optical path length of at least one second of said  $N$  light channels.

**103.** The device according to claim **90**, wherein for each of said  $N$  light channels, said optical path length has a value related to manufacturing irregularities of the passive optical components of the set of passive optical components of the respective associated optics member, said optics member comprising at least one lens element, said manufacturing irregularities comprising a deviation of a characteristic magnitude of said at least one lens element from a nominal value.

**104.** The device according to claim **103**, said nominal value being a focal length of said at least one lens element.

**105.** The device according to claim **90**, wherein for each of said  $N$  light channels, said optical path length has a value chosen in dependence of manufacturing irregularities of the passive optical components of the set of passive optical components of the respective associated optics member, said optics member comprising at least one lens element, said manufacturing irregularities comprising a deviation of a characteristic magnitude of said at least one lens element from a nominal value.

**106.** The device according to claim **105**, said nominal value being a focal length of said at least one lens element.

**107.** The device according to claim **90**, wherein each of said  $N$  light channels and its respective associated set of passive optical components are arranged relative to each other such that light impinging, from an object side, on a set of passive optical components can traverse said spacer member through the respective associated light channel.

**108.** The device according to claim **90**, wherein at least one of said  $N$  light channels comprises a blind hole in said spacer member wherein said at least one blind hole is provided for contributing to achieving said difference in optical path length between said at least one of said  $N$  light channels and at least one second of the light channels.

**109.** The device according to claim **90**, wherein at least two of said  $N$  light channels comprise a blind hole in said spacer member.

**110.** The device according to claim **109**, wherein a length of a first of said at least two blind holes is different from a length of a second of said at least two blind holes.

**111.** The device according to claim **90**, wherein each of said  $N$  sets of passive optical components has a characteristic

magnitude, said characteristic magnitude being nominally identical for all of said  $N$  sets of passive optical components.

**112.** The device according to claim **90**, wherein said optics member is manufactured using replication.

**113.** The device according to claim **90**, comprising a member referred to as detection member, said detection member comprising  $N$  active optical components, each of said  $N$  active optical components being associated with one of said  $N$  sets of passive optical components.

**114.** The device according to claim **113**, wherein the device is a device for capturing  $N$  sub-images, one by means of one of said  $N$  active optical components each.

**115.** The device according to claim **114**, comprising a microprocessor operationally connected to each of said  $N$  active optical components, wherein said microprocessor is configured for processing said  $N$  sub-images for generating a full image from said  $N$  sub-images.

**116.** The device according to claim **90**, wherein the device is an opto-electronic module.

**117.** The device according to claim **90**, wherein the device is at least one of the group consisting of a multi-aperture camera, a plenoptic camera, an array camera, a computational camera.

**118.** An appliance comprising a multitude of devices according to claim **90**.

**119.** The appliance according to claim **118**, wherein the appliance comprises at least one wafer comprising  $M \geq 2$  devices, each of the devices comprising an optics member and a spacer member, said optics member comprising  $N \geq 2$  sets of passive optical components comprising one or more passive optical components each, said spacer member comprising  $N$  light channels, each of said  $N$  light channels being associated with one of said  $N$  sets of passive optical components, wherein all of said  $N$  light channels have an at least substantially identical geometrical length, and wherein an optical path length of a first of said  $N$  light channels is different from an optical path length of at least one second of said  $N$  light channels, wherein said spacer member comprises a first layer and a second layer which are made of mutually different materials.

**120.** An appliance comprising a wafer referred to as spacer wafer, said spacer wafer comprising  $M \geq 2$  spacer members, each of said spacer members comprising  $N \geq 2$  light channels, wherein for each of said spacer members applies that all of the respective  $N$  light channels have an at least substantially identical geometrical length and an optical path length of a first of the respective  $N$  light channels is different from an optical path length of at least one second of said respective  $N$  light channels, wherein  $M$  is an integer and  $N$  is an integer, and wherein said spacer wafer comprises a first layer and a second layer which are made of mutually different materials.

**121.** The device according to claim **120**, wherein said second layer is made of a polymer material.

**122.** The device according to claim **121**, wherein said first layer is made of a different polymer material.

**123.** The device according to claim **120**, wherein first layer is made of glass.

**124.** The appliance according to claim **120**, wherein said geometrical length of a first one of said  $M$  spacer members is different from said geometrical length of at least a second one of said  $M$  spacer members.

**125.** The appliance according to claim **120**, comprising a wafer referred to as optics wafer, said optics wafer comprising  $M$  optics members comprising  $N$  sets of passive optical

components each, each of said N sets of passive optical components comprising one or more passive optical components.

**126.** The appliance according to claim **125**, wherein said spacer wafer and said optics wafer are comprised in a wafer stack.

**127.** The appliance according to claim **125**, wherein each of said M optics members is associated with a different one of said M spacer members.

**128.** The appliance according to claim **120**, wherein said first and second layers are substantially plate-shaped.

**129.** The appliance according to claim **120**, wherein said first layer and said second layer form a generally laterally extended interface.

**130.** The appliance according to claim **129**, wherein said first layer and said second layer are bonded with respect to each other at said generally laterally extended interface.

**131.** The device according to claim **120**, wherein a vertical extension of said first layer is substantially identical for each of said light channels.

**132.** The appliance according to claim **120**, comprising a wafer referred to as detection wafer, said detection wafer comprising M detection members comprising N active optical components each.

**133.** The appliance according to claim **132**, wherein each of said M detection members is associated with a different one of said M spacer members.

**134.** The appliance according to claim **132**, wherein each of said M×N light channels is associated with a different one of said M×N active optical components.

\* \* \* \* \*