



US006292979B1

(12) **United States Patent**
Kuo

(10) **Patent No.:** **US 6,292,979 B1**
(45) **Date of Patent:** **Sep. 25, 2001**

(54) **POSITIONING STRUCTURE OF
RETRACTABLE DRAW BAR FOR A
SUITCASE**

(75) Inventor: **Chung-Hsien Kuo**, Taipei Hsien (TW)

(73) Assignee: **Chaw Khong Technology Co., Ltd.**,
Taipei Hsien (TW)

(*) Notice: Subject to any disclaimer, the term of this
patent is extended or adjusted under 35
U.S.C. 154(b) by 0 days.

(21) Appl. No.: **09/598,023**

(22) Filed: **Jun. 21, 2000**

(51) **Int. Cl.**⁷ **A45C 3/00**; B25G 1/04

(52) **U.S. Cl.** **16/113.1**; 16/429; 16/DIG. 41;
403/326

(58) **Field of Search** 16/113.1, 405,
16/429, DIG. 41; 190/115, 18 A, 18 R;
280/47.315, 47.371, 655.1, 655; 403/326,
328, 319, 316

(56) **References Cited**

U.S. PATENT DOCUMENTS

5,653,000 * 8/1997 ILee 16/113.1
5,890,257 * 4/1999 Edele et al. 403/326
6,202,254 * 3/2001 Ezer 16/113.1

* cited by examiner

Primary Examiner—Chuck Y. Mah

(74) *Attorney, Agent, or Firm*—Rosenberg, Klein & Lee

(57) **ABSTRACT**

The present invention proposes a positioning structure of a retractable draw bar, wherein an extended sheet is formed at the upper edge of each of the retaining holes of the first joint tube to increase the area of the upper edge of the retaining hole. When the retaining buttons of the positioning seat is fastened in the retaining holes and bear an upward force, the contact area of the upper edges thereof will be larger. Therefore, the retaining buttons can bear larger load so that they will not break or be damaged because of large shearing force. The lifetime can thus be greatly increased.

5 Claims, 6 Drawing Sheets

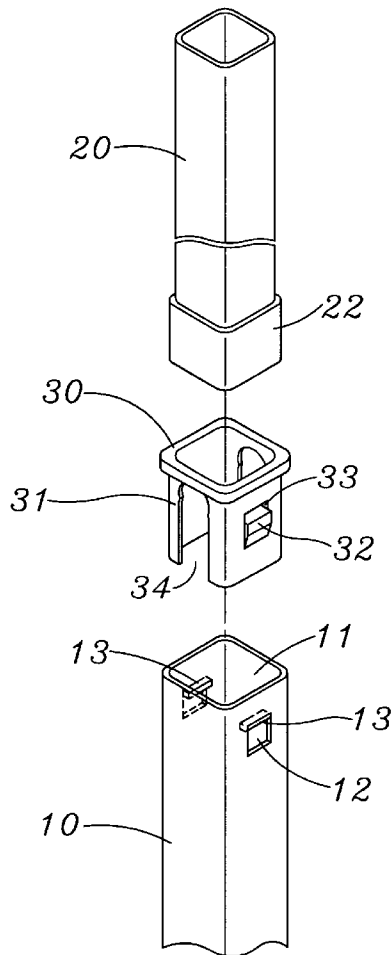

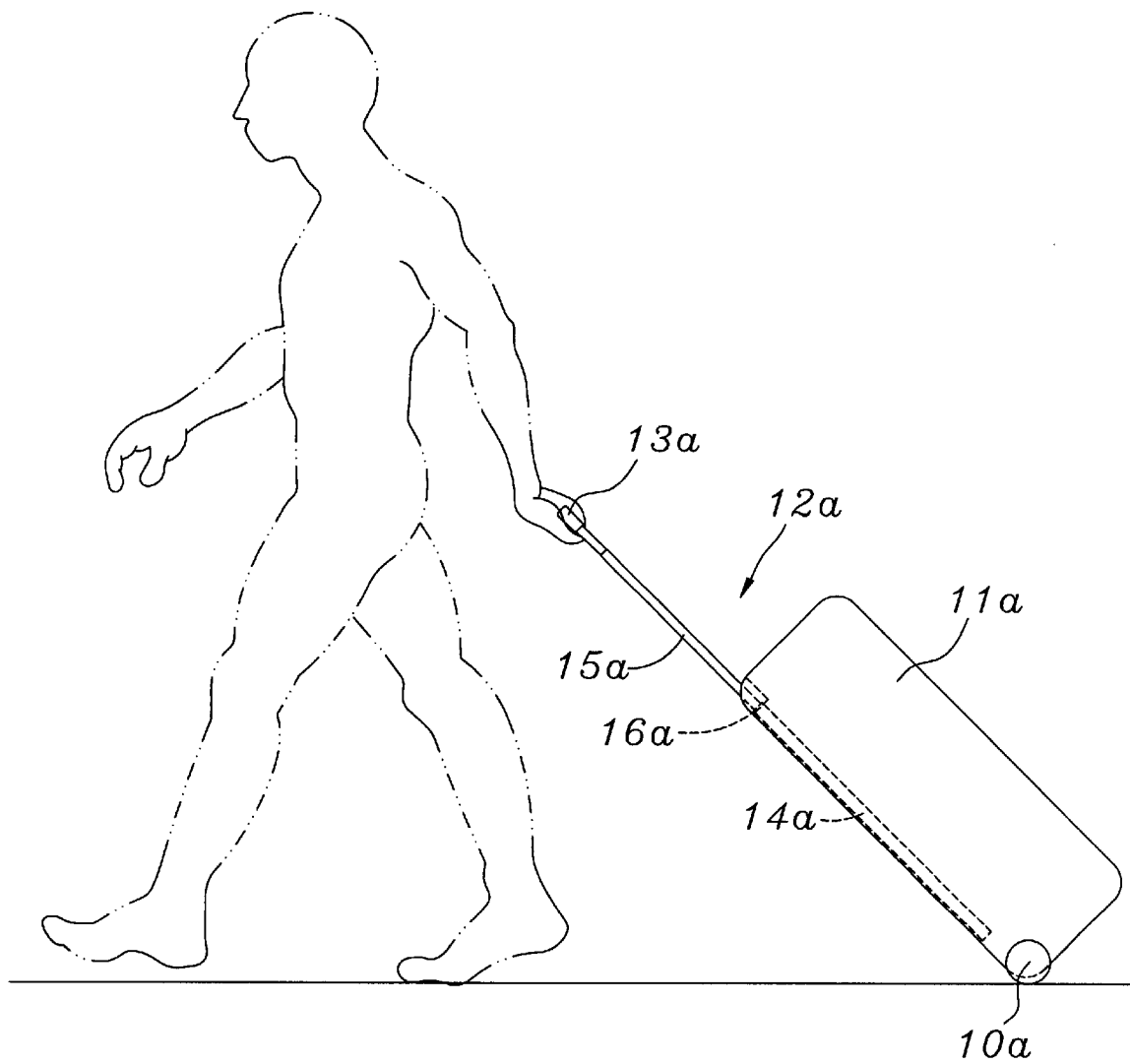

FIG. 1
PRIOR ART

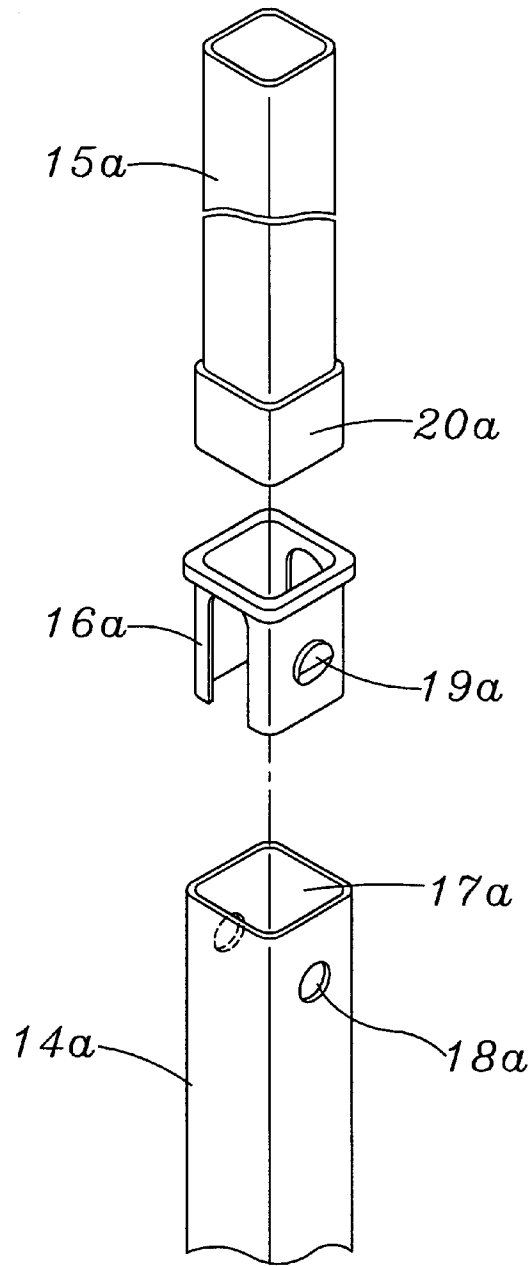

FIG. 2
PRIOR ART

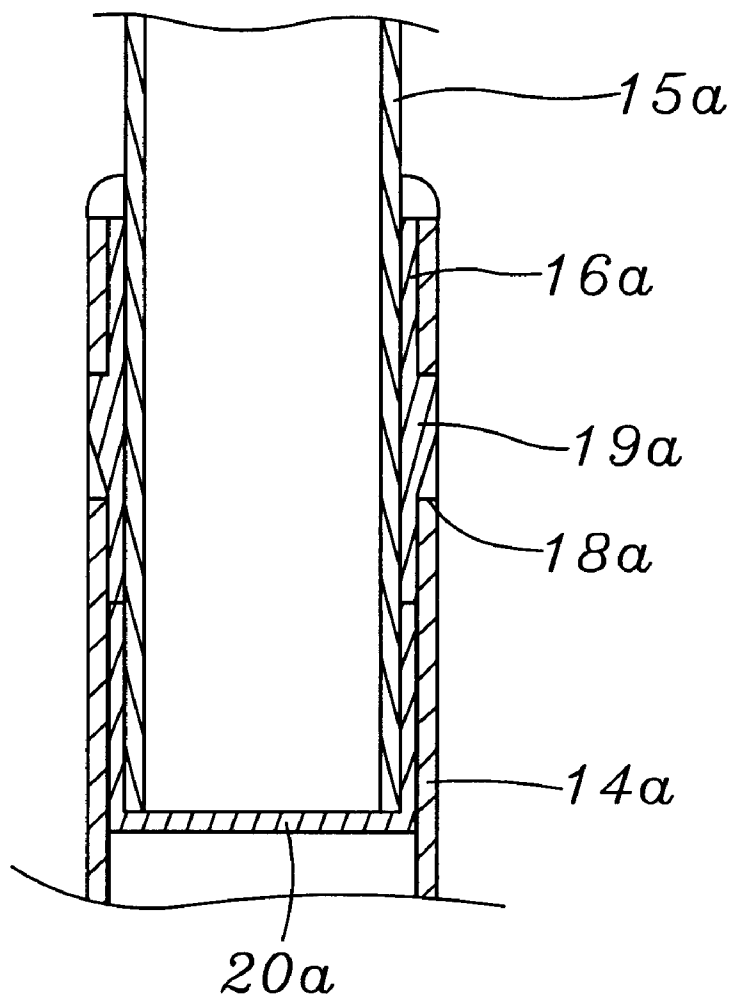

FIG. 3
PRIOR ART

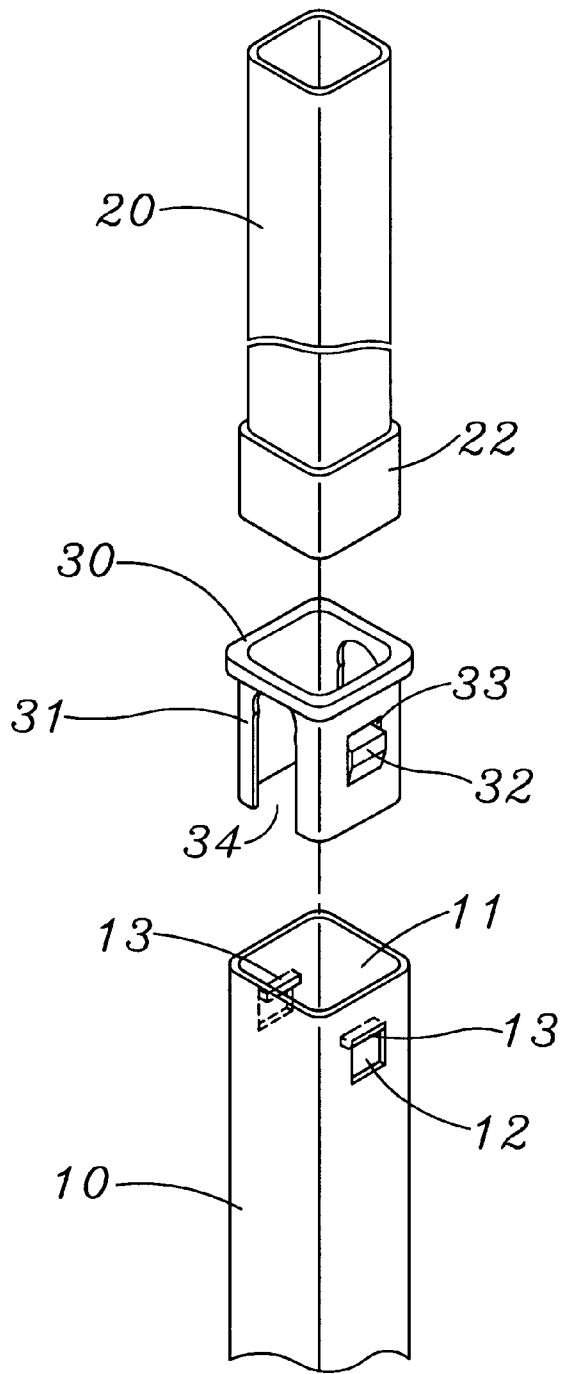

FIG. 4

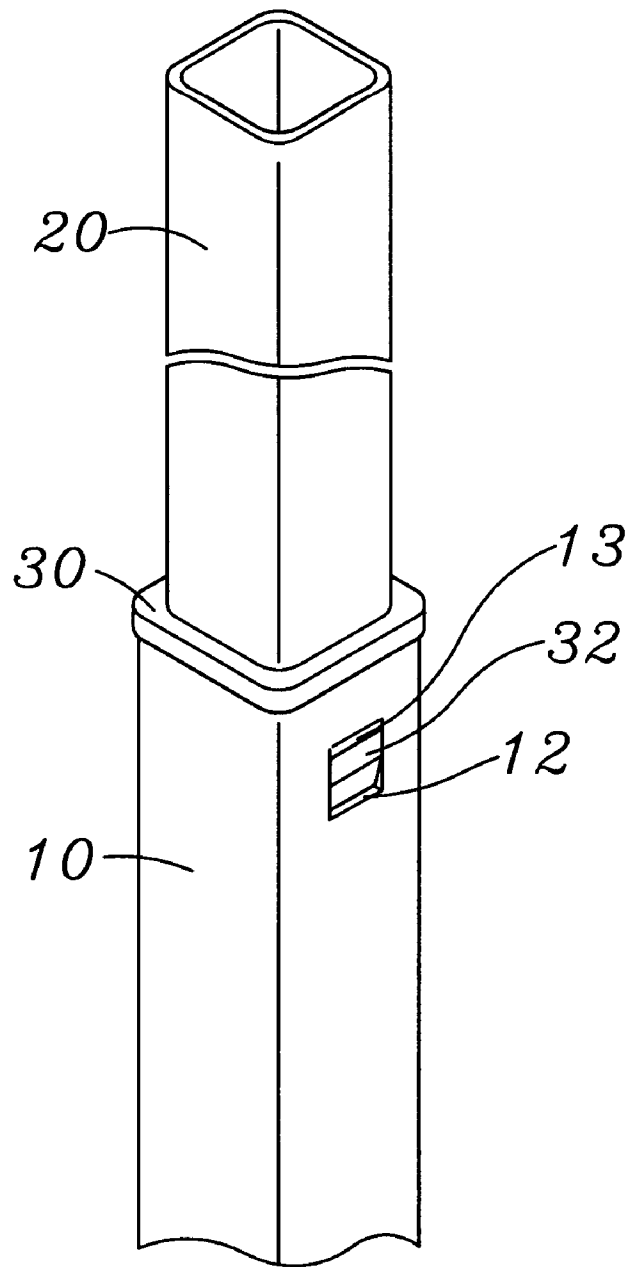

FIG. 5

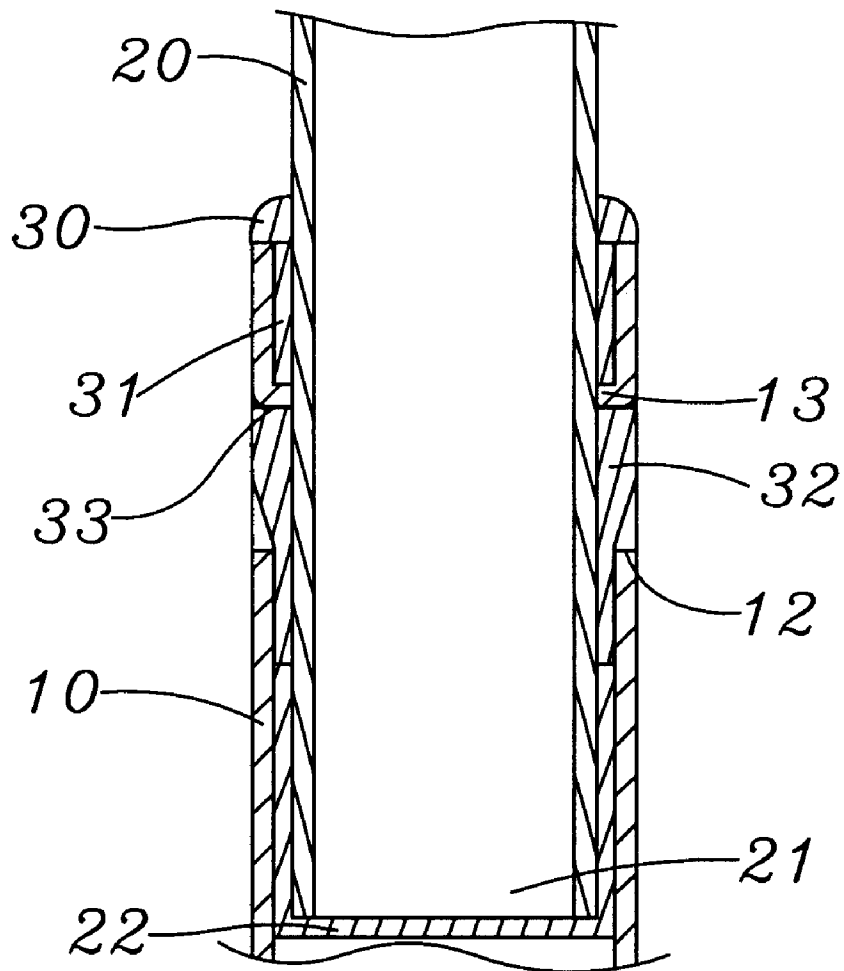

FIG. 6

1

POSITIONING STRUCTURE OF RETRACTABLE DRAW BAR FOR A SUITCASE

FIELD OF THE INVENTION

The present invention relates to a positioning structure of a retractable draw bar for a suitcase and, more particularly, to a positioning structure of a retractable draw bar letting the joining of a first joint tube and a positioning seat be steadier. The present invention also has the advantage that the retaining button of the positioning seat will not break or be damaged so that the lifetime can be greatly increased.

BACKGROUND OF THE INVENTION

For a suitcase **11a** shown in FIG. 1 with rollers **10a** installed at the bottom thereof, there is a retractable draw bar **12a** allocated to facilitate the protraction/retraction of a pull handle **13a** so that the pull handle **13a** can be pulled out to a full extent to be gripped conveniently when used and be retracted to a compact position when not used.

As shown in FIGS. 2 and 3, the retractable draw bar **12a** comprises basically a first joint tube **14a**, a second joint tube **15a**, and a positioning seat **16a**. The caliber of the first joint tube **14a** is slightly larger than that of the second joint tube **15a** so that the second joint tube **15a** can be retractably inserted therein. Two circular retaining holes **18a** are respectively disposed on two opposite tube walls near an upper opening **17a** of the first joint tube **14a**. The positioning seat **16a** is sheathed in the upper opening **17a** of the first joint tube **14a**. Two circular retaining buttons **19a** are respectively formed on two opposite sides of the positioning seat **16a**. The positioning seat **16a** can be joined at the upper opening **17a** through the fastening of the retaining buttons **19a** in the retaining holes **18a**. A fixing element **20a** can be fixed in the lower opening of the second joint tube **15a**. When the second joint tube **15a** is pulled upwards in the first joint tube **14a** until the fixing element **20a** sticks to the positioning seat **16a**, the second joint tube **15a** can be positioned there so that it will not slide out of the first joint tube **14a**.

However, in the above positioning structure of a retractable draw bar in prior art, the positioning seat **16a** and the first joint tube **14a** are joined through the fastening of the retaining buttons **19a** in the retaining holes **18a**. When the second joint tube **15a** is pulled upwards, the positioning seat **16a** will bear an upward force. The retaining buttons **19a** and the retaining holes **18a** will bear this force via the upper edges thereof. Because the contact area of the upper edges of the retaining buttons **19a** and the retaining holes **18a** is very small, the retaining buttons **19a** will easily break or be damaged because of large pressure. Therefore, the positioning seat **16a** can not be steadily joined at the upper opening **17a** of the first joint tube **14a** so that the positioning seat **16a** can not achieve its original positioning function.

SUMMARY AND OBJECTS OF THE PRESENT INVENTION

The primary object of the present invention is to provide a positioning structure of a retractable draw bar, wherein the contact area of the retaining buttons and the retaining holes can be increased so that the retaining buttons can bear larger load when the positioning seat bears an upward force. Thereby, the retaining buttons will not break or be damaged because of large shearing force. The positioning seat thus can be steadily joined at the upper opening of the first joint tube to achieve its positioning function.

2

To achieve the above object, the present invention provides a positioning structure of a retractable draw bar, which comprises at least a first joint tube and a positioning seat. Two retaining holes are respectively disposed at two opposite tube walls near an upper opening of the first joint tube. An extended plate raised on the inner wall of the first joint tube is formed at the upper edge of each retaining hole. Two retaining buttons are respectively formed on two opposite sides of the positioning seat. The positioning seat is sheathed in the upper opening of the first joint tube. The positioning seat is joined at the upper opening of the first joint tube through the fastening of the retaining buttons in the retaining holes with the extended sheets situated above the retaining buttons of the positioning seat.

The various objects and advantages of the present invention will be more readily understood from the following detailed description when read in conjunction with the appended drawings, in which:

BRIEF DESCRIPTION OF DRAWING

FIG. 1 is a plan view of a suitcase in use in prior art;

FIG. 2 is an exploded perspective view of a positioning structure of a retractable draw bar in prior art;

FIG. 3 is a cross-sectional view of a positioning structure of a retractable draw bar in prior art;

FIG. 4 is an exploded perspective view of the present invention;

FIG. 5 is a perspective view of the present invention;

FIG. 6 is a cross-sectional view of the present invention.

DETAILED DESCRIPTION OF PREFERRED EMBODIMENT

FIG. 4 shows a positioning structure of a draw bar applied to a suitcase or any other device having a retractable draw bar to facilitate the protraction/retraction of a pull handle so that the pull handle can be pulled out to a full extent to be gripped conveniently when used and be retracted to a compact position when not used. The positioning structure of a retractable draw bar of the present invention comprises a first joint tube **10**, a second joint tube **20**, and a positioning seat **30** (please also refer to FIGS. 5 and 6). The first joint tube **10** is a rectangular tube with a caliber slighter larger than that of the second joint tube **20**. Two rectangular retaining holes **12** are respectively disposed on two opposite tube walls near an upper opening **11** of the first joint tube **10**. An extended plate **13** raised on the inner wall of the first joint tube **10** is formed at the upper edge of each retaining hole **12**.

The second joint tube **20** is also a rectangular tube and is retractably inserted in the first joint tube **10**. A fixing element **22** is fixed at a lower opening **21** of the second joint tube **20**.

The positioning seat **30** is a rectangular hollow seat whose bottom forms a plugging part **31**. Two rectangular retaining buttons **32** are respectively formed on two opposite sides of the plugging part **31**. A through hole **33** penetrating through one side wall of the plugging part **31** is disposed above each of the retaining buttons **32**. Two cut trenches **34** whose bottom ends are open are respectively disposed on the other two opposite sides of the plugging part **31**. The plugging part **31** of the positioning seat **30** is sheathed in the upper opening **11** of the first joint tube **10**. The positioning seat **30** is joined at the upper opening **11** through the fastening of the retaining buttons **32** in the retaining holes **12** with the extended sheets **13** of the first joint tube **10** inserted in the through holes **33** of the positioning seat **30** and situated above the retaining buttons **32** of the positioning seat **30**. Thereby, the positioning seat **30** can be joined at the upper opening **11** of the first joint tube **10**.

3

As shown in FIG. 6, the present invention is characterized in that the extended sheet 13 is formed at the upper edge of each of the retaining holes 12 of the first joint tube 10 to increase the contact area of the upper edges of the retaining holes 12. Moreover, the contact surface of the retaining holes of the first joint tube 10 with the retaining buttons 32 of the positioning seat 30 is flat. When the second joint tube 20 is pulled upwards until the fixing element 22 at the bottom end of the second joint tube 20 sticks to the positioning seat 30, the positioning seat will bear an upward force. The retaining buttons 32 and the retaining holes 12 will bear this force via the upper edges thereof. Because the contact area of the upper edges of the retaining buttons 32 and the retaining holes 12 is larger, larger load can be born. The retaining buttons 32 will not break or be damaged because of large shearing force. The positioning seat 30 can thus be steadily joined at the upper opening 11 of the first joint tube 10 to achieve its positioning function.

Although the present invention has been described with reference to the preferred embodiments thereof, it will be understood that the invention is not limited to the details thereof. Various substitutions and modifications have suggested in the foregoing description, and other will occur to those of ordinary skill in the art. Therefore, all such substitutions and modifications are intended to be embraced within the scope of the invention as defined in the appended claims.

I claim:

1. A positioning structure of a retractable draw bar comprising at least:
 - a first joint tube with two retaining holes respectively disposed on two opposite tube walls near an upper

4

opening thereof, an extended sheet raised on the inner tube wall thereof being formed at the upper edge of each of said retaining holes; and

a positioning seat with two retaining buttons respectively formed on two opposite sides thereof, said positioning seat being sheathed in said upper opening of said first joint tube, said positioning seat being joined at said upper opening through the fastening of said retaining buttons in contact with said retaining holes with said extended sheets of said first joint tube situated above said retaining buttons of said positioning seat.

2. The positioning structure of a retractable draw bar of claim 1, wherein the contact surface of said retaining holes of said first joint tube with said retaining buttons of said positioning seat is flat.

3. The positioning structure of a retractable draw bar of claim 1, wherein the bottom of said positioning seat forms a plugging part to be sheathed in said upper opening of said first joint tube, and said retaining buttons are respectively formed on two opposite sides of said plugging part of said positioning seat.

4. The positioning structure of a retractable draw bar of claim 1, wherein a through hole is disposed above each of said retaining buttons, and said extended sheets of said first joint tube are inserted in said through holes of said positioning seat.

5. The positioning structure of a retractable draw bar of claim 1, wherein two cut trenches whose bottoms are open are respectively disposed on other two opposite sides of said positioning seat.

* * * * *