

C. Vignal.

Mashing & Cutting Vegetables.

N^o 75605

Patented Mar. 17, 1868.

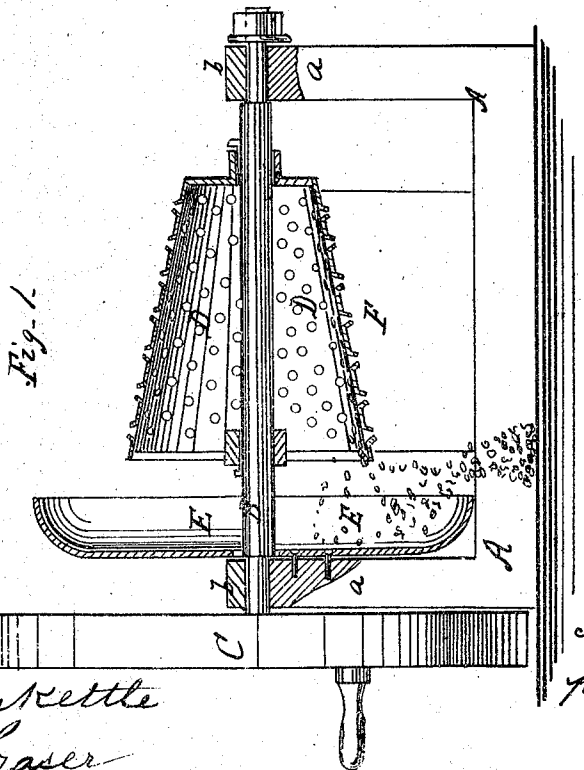
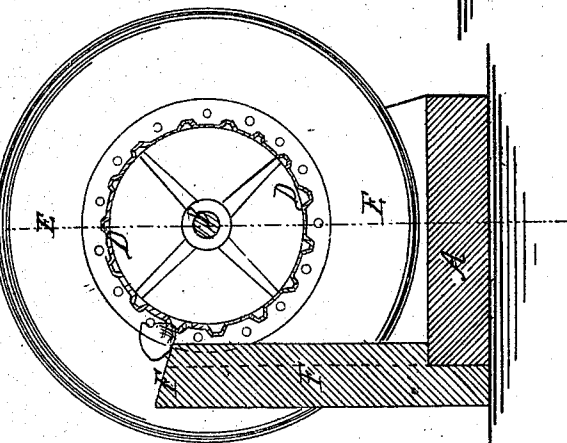
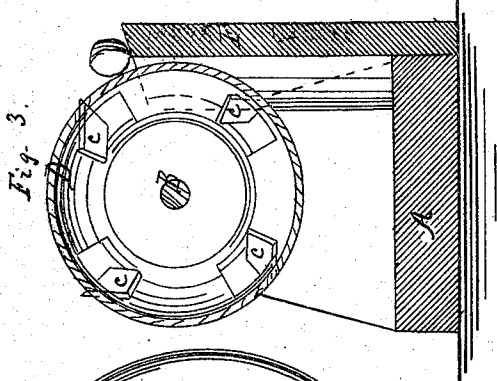

Witnesses.

W. C. Ashkettle

J. A. Fraser

Inventor.

C. Vignal
per Munnell
attorneys

United States Patent Office.

CARL VIGNAL, OF NEW YORK, N. Y.

Letters Patent No. 75,605, dated March 17, 1868.

IMPROVED VEGETABLE-MASHING AND CUTTING MACHINE.

The Schedule referred to in these Letters Patent and making part of the same.

TO ALL WHOM IT MAY CONCERN:

Be it known that I, CARL VIGNAL, of the city, county, and State of New York, have invented a new and improved Vegetable-Mashing and Cutting Machine; and I do hereby declare that the following is a full, clear, and exact description thereof, which will enable others skilled in the art to make and use the same, reference being had to the accompanying drawings, forming part of this specification, in which—

Figure 1 represents a longitudinal vertical section of my improved vegetable-mashing machine.

Figure 2 is a vertical transverse section of the same.

Figure 3 is a vertical transverse section of the same, showing the device converted into a vegetable-cutter.

Similar letters of reference indicate corresponding parts.

This invention relates to a new apparatus for mashing or cutting all sorts of vegetable or other suitable material, and consists of a hollow conical grating or cutting-roller mounted on a horizontal shaft, with open large end, and of a concave shield set opposite the open end, so that when the cone is revolved, and the article to be cut or mashed held against its surface, the detached particles will enter the cone through perforations in its shell, and will either fall down on its lower inclined inner surface or will be thrown against the shield, and will, by the same, be conducted to the same receptacle into which they fall directly from the cone.

A, in the drawing, represents a frame of suitable size and material, in uprights *a a* of which a horizontal shaft, B, has its bearings. On the shaft B are mounted a fly-wheel, C, and a truncated hollow cone, D, as shown in fig. 1. One or both of the caps *b* of the shaft-journals are hinged, so that the shaft can be removed to be replaced by another, or to allow the removal of the cone D from it and its replacement by another cone. The large end of the cone D is open, the smaller one closed, as shown. E is a stationary concave shield fixed opposite to the open end of the cone, as shown. The cone is either provided with a perforated grating-surface, as in figs. 1 and 2, or it is slotted and has cutters, *c c*, as in fig. 3. F is a stationary or movable rest, having an inclined upper surface, and being arranged so as to allow the article to be cut to be placed upon it and to be held against the cone, as in figs. 2 and 3.

If the grating-cone is used, the particles detached from the piece to be mashed enter the interior of the cone, and fall down on its lower inclined inner face, or they are thrown against the shield E, which prevents their being spread about, and which causes them to be gathered in a suitable receptacle placed below the large end of the cone. The same results are obtained if the cutting-cone is employed.

Having described my invention, what I claim as new, and desire to secure by Letters Patent, is—

The combination of the removable truncated cone D, provided with the graters or cutters *c*, the revolving curved gathering-shield E, rest F, and hinged bearings *b*, said cones and shield revolving upon the shaft B independently of each other, all constructed and arranged to operate as herein described for the purpose specified.

CARL VIGNAL.

Witnesses:

WM. F. McNAMARA,
ALEX. F. ROBERTS.