

(19) World Intellectual Property Organization  
International Bureau



(43) International Publication Date  
11 March 2004 (11.03.2004)

PCT

(10) International Publication Number  
WO 2004/020023 A2

(51) International Patent Classification<sup>7</sup>: A61M 5/00

Lasse, Wesseltoft [DK/DK]; Jacob Bulls Allé 100, 1., DK-2860 Søborg (DK). GÖRANSSON, Magnus, Walter [SE/SE]; Folkungagatan 11, SE-41102 Gøteborg (SE).

(21) International Application Number:  
PCT/DK2003/000572

(74) Agent: ZACCO DENMARK A/S; Hans Bekkevolds Alle 7, DK-2900 Hellerup (DK).

(22) International Filing Date:  
2 September 2003 (02.09.2003)

(81) Designated States (*national*): AE, AG, AL, AM, AT (utility model), AT, AU, AZ, BA, BB, BG, BR, BY, BZ, CA, CH, CN, CO, CR, CU, CZ (utility model), CZ, DE (utility model), DE, DK (utility model), DK, DM, DZ, EC, EE (utility model), EE, ES, FI (utility model), FI, GB, GD, GE, GH, GM, HR, HU, ID, IL, IN, IS, JP, KE, KG, KP, KR, KZ, LC, LK, LR, LS, LT, LU, LV, MA, MD, MG, MK, MN, MW, MX, MZ, NI, NO, NZ, OM, PG, PH, PL, PT (utility model), PT, RO, RU, SC, SD, SE, SG, SK (utility model), SK, SL, SY, TJ, TM, TN, TR, TT, TZ, UA, UG, US, UZ, VC, VN, YU, ZA, ZM, ZW.

(25) Filing Language: English

(26) Publication Language: English

(30) Priority Data:  
PA 2002 01286 2 September 2002 (02.09.2002) DK

(71) Applicant (*for all designated States except US*): UN-OMEDICAL A/S [DK/DK]; Engmosen 1, DK-3540 Lyngø (DK).

(84) Designated States (*regional*): ARIPO patent (GH, GM, KE, LS, MW, MZ, SD, SL, SZ, TZ, UG, ZM, ZW), Eurasian patent (AM, AZ, BY, KG, KZ, MD, RU, TJ, TM),

(72) Inventors; and

(75) Inventors/Applicants (*for US only*): MOGENSEN,

[Continued on next page]

(54) Title: AN APPARATUS AND A METHOD FOR ADJUSTMENT OF THE LENGTH OF AN INFUSION TUBING

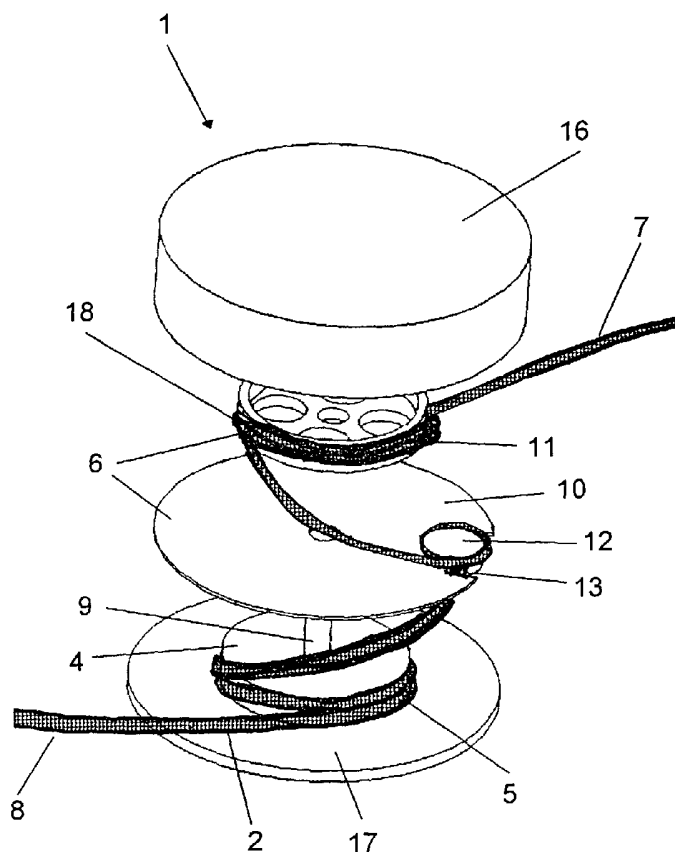

(57) Abstract: The invention relates to an apparatus/a medical utensil (1) for adjustment of the length of an infusion tubing (2), comprising a housing (3) with an axle/cylinder part (4) arranged about a center axis, said housing (3) further comprising at least one turnable unit (6), wherein the housing (3) comprises a first axle (4); and about which axle (9) the turnable unit (6) turns. Hereby winding is enabled of an infusion tubing with adjustment of the connecting length between pump and the site of infusion, and wherein the apparatus is independent of infusion cannula and pump. The apparatus enables reuse due to said independence. The system also enables the user to locate the winding unit anywhere on his body he may find suitable with regard to physiology and with regard to clothing. It is thus possible to arrange it underneath one's sweater, in one's waistband, pocket or the like. Moreover an automatic winder is accomplished, and wherein increase and reduction of the length is accomplished in a simple manner. The construction is particularly suitable for the handicapped, and likewise it saves time for hospital staff in connection with patients who use infusion units.

WO 2004/020023 A2



European patent (AT, BE, BG, CH, CY, CZ, DE, DK, EE, ES, FI, FR, GB, GR, HU, IE, IT, LU, MC, NL, PT, RO, SE, SI, SK, TR), OAPI patent (BF, BJ, CF, CG, CI, CM, GA, GN, GQ, GW, ML, MR, NE, SN, TD, TG).

*For two-letter codes and other abbreviations, refer to the "Guidance Notes on Codes and Abbreviations" appearing at the beginning of each regular issue of the PCT Gazette.*

**Published:**

— *without international search report and to be republished upon receipt of that report*

## **An apparatus and a method for adjustment of the length of an infusion tubing**

The invention relates to an apparatus/a medical utensil for adjustment of the  
5 length of an infusion tubing, comprising a housing with an axle/cylinder part  
arranged around a central axis, said housing further comprising at least one  
turnable unit.

The invention also relates to a method for adjustment of the length of an  
10 infusion tubing by means of an apparatus comprising a housing with an  
axle/cylinder part arranged around a central axis, said housing further  
comprising at least one turnable unit.

When infusion kits are used in combination with an insulin pump it is  
15 necessary to use a tubular element of a certain length, since the distance  
between the insulin pump and the cannula housing will vary. This variation in  
the distance between pump and cannula occurs ia during the night when the  
pump sits on the nightstand. In that case the tubing may be used in its full  
length. When, during the daytime, the pump is arranged in the belt of the  
20 diabetic, the requisite tubing length will be shorter – but still variable, since  
the cannula may be inserted in different places in the body.

Therefore the problem of excessive tubing may occur that the user may find  
difficult to arrange/conceal. That means that when cannula housing is  
25 arranged in the immediate vicinity of the pump and the user simultaneously  
uses a long tubing of 110 cm, a worst case scenario will involve about 90 cm  
that are not “in use”.

It is desired to develop a winding device that is able to compensate for the  
30 above-described problem.

The winding device is typically located close to the skin – underneath the clothes. Optionally by means of a clip to the trouser waistband.

5 The winding device must not be able to cause failures of any kind in the supply of insulin; neither by damage to/deformation of tubing nor in any other way.

10 WO 96/35472 teaches an apparatus of the kind described above; it describes a portable medical pump wherein a winding unit is integrated for the infusion tubing. The drawback of this system is that, apart from the tubing constituting an integral part of the pump device, such system is mechanically complex and restricts the place where the winding may occur to a place near the infusion part and not anywhere on the tubing nor on just any tubing, the winding system being designed exclusively for the pump of which it is an  
15 integral part. To the user the system is not particularly flexible, since it is not possible to locate the pump unit and the winding unit apart. Therefore the unit will be very visible to the user when he wears the pump unit.

20 It is thus the object of the present invention to provide an apparatus wherein the above-referenced drawbacks are overcome, and whereby it is possible to perform a winding of an infusion tubing to adjust the connecting length between pump and the infusion site, the apparatus being independent of infusion cannula and pump. Thus the apparatus enables reuse due to said independence. The system also makes it possible for the user to locate the  
25 winding unit anywhere on the body he finds suitable with regard to physiology and with regard to clothing. It is thus an option to arrange it underneath one's sweater, in one's waistband, pocket or the like.

30 Moreover, an automatic winder is obtained and wherein length increases and reductions are accomplished in a simple manner. The structure is also suitable for the handicapped and, likewise, it is a time-saving device for use

- by hospital staff in the context of patients who use infusion units, the unit being able to accommodate a considerably long tubing, and wherein the staff is thus able to adjust the length of the tubing in a simple manner, depending on whether the patient is confined to his bed and needs a relatively long
- 5 tubing from and infusion pump to the patient in his bed, or whether the patient is not confined to his bed and has an infusion device/pump arranged on his body, which means that the tubular connection between that and the site of infusion needs to be short.
- 10 This object is accomplished by means of an apparatus of the kind described above and wherein the housing also comprises a first axle, the centre axis of which coincides with the centre axis of the axle, and about which axle the turnable unit turns.
- 15 The object is also accomplished by a method of the kind described above, and wherein a first length of tubing is wound around the axle; a second length of tubing is wound around parts of the turnable unit; and a first free end portion and a second free end portion are situated outside the housing.
- 20 The apparatus works in that a tubing is mounted in the housing such that, from the housing, two free tubular elements extend, where the one tubular element is connected to an infusion cannula, and wherein the second tubular element is connected to an infusion pump. The two tubing ends will typically be configured such that the one tubing end is adjustable in length, while the
- 25 the second tubing end has a fixed distance to the housing as such. About half of the tubing is wound around a so-called winder wheel situated within the housing proper and being fixedly/non-turnably journalled, albeit it may also be turnable. The tubing is conveyed around an auxiliary means within the housing as such, designated a return wheel, such that the tubing is caused to
- 30 proceed to an upper rotatable wheel, and wherein the tubing is, in relation to the fixed winder wheel, extending in the one direction of rotation, while the

tubing wound around the rotatable winder wheel will be extending in the opposite direction. The free end of the tubing is subsequently led out through the housing. The tubing length is distributed such that there are equal lengths of tubing wound on the fixed winder wheel and the rotating winder wheel,  
5 respectively.

When a pull is thus exerted at the end of the tubing that is in direct communication with the rotating winder wheel, the following occurs:

10 The tubing is unwound from the rotating wheel and thus constitutes the extension. The rotating wheel turns on the axle due to the pull that is exerted on the tubing, and due to the internal construction tubing will be conveyed from the lower fixed winder wheel to the rotating wheel. The construction of the individual elements means that the transfer from the one wheel to the  
15 other will constitute a length of tubing, whose length is half that unwound from the winder.

Finally, it is an option to let a part of the interior, corresponding to the part designated the partition plate, be spring-biased such that it is possible to  
20 have the tubing pulled into the apparatus/winder.

By providing an apparatus according to the invention and as further featured in claim 2 it is accomplished that only the one end of the tubing can be pulled out of the housing. The term 'stationary' as used in this context is intended to  
25 designate 'non-turnable' and 'immovable'.

By providing an apparatus according to the invention and as further featured in claim 3 it is accomplished that both ends of the tubing can be pulled out of the housing.

30

By providing an apparatus according to the invention and as further featured in claims 4-6 an expedient embodiment of the apparatus is accomplished.

5 By providing an apparatus according to the invention and as further featured in claim 7 it is an option to automatically pull the tubing back into the housing again.

10 By providing an apparatus according to the invention and as further featured in claim 8 convenient exchange is accomplished between the two cylinder parts.

The invention also relates to a method as featured in claims 7-12.

15 Finally the invention also relates to use of the apparatus as recited in claims 13 and 14.

The invention will now be explained in further detail with reference to the drawing, wherein:

20 Figure 1 is an exploded view of an apparatus according to the invention containing the individual elements;

25 Figure 2 shows the apparatus shown in Figure 1, but wherein the location of the tubing in relation to the individual constituent components is indicated;

Figure 3 shows an apparatus according to the invention, seen in a perspective view.

30 Figure 1 shows an apparatus 1 in an exploded view, with a housing 3 and comprising an upper part 16 and a lower part 17. Both the upper and the lower parts are circularly configured pieces, wherein the lower part is plate-

shaped. Coaxially on this plate, an axle/cylinder part 4 is arranged, in this case also designated fixed winder wheel/stationary axle, about which a part of an infusion tubing 2 can be wound. It is noted that the cylinder part 4 can be turnable and/or it can be locked by means of eg a manually operated lock.

5 In this embodiment, the cylinder part 4, however, is not turnable. In parallel with the axis and coincident therewith, a first axle 9 extends, and on said first axle 9 a first plate 10, also designate the partition plate, is arranged. Thus, the partition plate 10 has a through-going bore, through which the axle 9 extends. In the periphery of the partition plate 10, a rectangular slit is

10 provided, in which a circular plate is secured, also designated return wheel 12, the diameter of which is considerably less than the diameter of the partition plate and about one third thereof, and wherein the outer periphery of said return wheel is flush with the periphery of the partition plate or is located within same.

15 Laterally to said return wheels, recesses 13 are shown that are configured to be so wide that the tubing is able to travel therethrough. In parallel with the axis of said partition plate and above there is arranged a rotating winder wheel/turnable wheel 11 that also comprises a through-going central bore that encircles the first axle 9.

20 This winder wheel is rotatable and, besides, the partition plate is also turnable about the axle 9. The rotatable winder wheel and the partition plate 10 constitute the turnable unit 6. The tubing is also wound around the rotating

25 winder wheel, from which an end part extends. Finally the housing ends at the top in an upper part 16 configured as a partially cylindrical dish that encircles the turnable unit 6 and ends close to the lower part 17 of the housing.

30 Figure 2 is identical to Figure 1, but the tubing 2 is shown herein in its mounted state. As will appear, the tubing 2 extends into the housing in one

direction and is wound around the fixed winder wheel, eg counter-clockwise. From here the tubing proceeds up through the recess 13 and is wound around the return wheel, following which the tubing is conveyed around rotating winder wheel 11, where this winding extends opposite the winding of  
5 the fixed winder wheel, ie clockwise. From here the tubing exits.

The functioning of the apparatus 1 is that the tubing 2 is conveyed into the winder such that a short length of the tubing 2 allows coupling to eg a pump. About half of the tubing, designated the first length of tubing 5, is wound  
10 around the fixed winder wheel 4. The tubing is subsequently conveyed around the return wheel 12. The return wheel is mounted on the plate 10 that separates the fixed and the rotating winder wheel. The return wheel ensures that the tubing is wound onto the rotating winder wheel 11 and the fixed winder wheel 4 in each their direction, ie clockwise/counter-clockwise.  
15 Simultaneously the return wheel 12 conveys the tubing 2 past the partition plate 10, such that the tubing 2 is conveyed from the fixed winder wheel 4 to the rotating winder wheel 11. The remainder of the tubing and designated the second length of tubing 18 is wound onto the rotating winder wheel 11. There are equal amounts of tubing wound on the two winder wheels in this  
20 example. When extension of the tubing is to be accomplished, the following occurs: the tubing 2 is unwound from the rotating wheel 11 by a pull in the length of tubing 7. The rotating wheel 11 turns about the axle 9, whereby the return wheel 12 will be forced to follow. Since, via the partition plate 10, the return wheel 12 rotates about the central axle 9, tubing will be transferred  
25 from the fixed to the rotating wheel.

Likewise, the return wheel 12 moves half the distance of the length of tubing unwound. This transfer will constitute a length of tubing, whose length is half that of the section that is unwound from the winder. Since the return wheel 12  
30 is relieved the rotating winder wheel 11 by twice half of the length of the unwound length of tubing, the requisite length of tubing is accomplished that

is required in order for the rotating winder wheel 11 to supply the user with the desired length of tubing.

5 Simultaneously the return wheel 12 has moved just as much in relation to the fixed winder wheel 4 that has unwound precisely the length of tubing that was transferred to the rotating winder wheel.

The above explanation presupposes that the dimensions of the individual elements are adapted in relation to each other; in this example a diameter D  
10 being used for the fixed winder wheel and the rotating winder wheel, while the partition plate as such has a diameter which is twice that. However, other dimensions and hence other exchange ratios may apply.

It should also be mentioned that both the fixed winder wheel and the rotating  
15 winder wheel have a height corresponding to the height of the winding of the tubing, and it follows that this height is a function of how much tubing is desired to be stored in the apparatus. The partition plate as such is relatively thin, its object being to carry the return wheel 12, which – as it is – is also rotatable about an axle mounted in the partition plate.

20

Thus, in its simplicity the winder consist of a minimum of seven parts, viz.

- A housing that contains the winder mechanism and which is approximately cylinder-shaped;
- 25 A central axle secured along the central axle of the housing;
- A fixed winder wheel secured on the axle;
- A partition plate mounted on the axle after the fixed wheel;
- A return wheel mounted on the partition plate; the axle of the return wheel being displaced in relation to the central axle such that the return wheel does  
30 not overlap the fixed wheel or the rotating wheel;

A spring configured in such a manner that it seeks to rotate the partition plate in that direction, whereby the tubing is tightened;

A rotating winder wheel mounted on the central axle.

- 5 Thus Figure 2 does not show the spring, but as mentioned it is located on the partition plate 10 and secured to the inner faces of the housing, whereby it is possible to tighten the tubing.

10 Finally Figure 3 provides a perspective view of the apparatus, wherein it comprises a hosing 3 with a tubing 2, from where a first end part and a second end part 7, 8 will appear that protrude from the first and second tubing branches 14, 15, respectively. Expediently the two exits for the first end part and the second end part, respectively, are situated diametrically opposite each other. The one end part can be extended, while the second  
15 end part has a stationary distance to the housing, or conversely.

Besides, it should be noted that the apparatus can be configured such that both ends on the tubing can be pulled outwards. That is, the axle 4 and the turnable wheel 11 can both be turnable. Both units can also be made non-  
20 turnable by means of a lock. In this manner the patient himself is able to regulate which of the two units is to be turnable and hence which of the tubing ends is to be adjustable in length, including optionally both ends.

Claims

1. An apparatus/a medical utensil (1) for adjustment of the length of an infusion tubing (2), comprising a housing (3) with an axle/cylinder part (4) arranged about a centre axis, said housing (3) further comprising at least one turnable unit (6), **characterised in** that the housing (3) comprises a first axle (9), the centre axis of which coincides with the centre axis of the axle (4), and about which axle (9) the turnable unit (6) turns.
2. An apparatus according to claim 1, **characterised in** that the axle (4) is a stationary axle.
3. An apparatus according to claim 1, **characterised in** that the axle (4) is a turnable axle.
4. An apparatus according to any one of the preceding claims, **characterised in** that the turnable unit (6) comprises a turnable first plate – partition plate – which is turnable about a first axle (9) and a wheel/cylinder part (11) turnable about the same axle.
5. An apparatus according to claim 4, **characterised in** that, at its periphery, the partition plate (10) comprises a circular plate/wheel – return wheel (12) – around the periphery of which lengths of the tubing abut.
6. An apparatus according to claim 5, **characterised in** that the return wheel (12) is turnable about an axle mounted on the partition plate.
7. An apparatus according to claims 4-6, **characterised in** that the apparatus comprises a spring, said spring being connected to the partition plate (10) and to a part which is stationary within the housing (3), preferably the walls of the housing (3).

8. An apparatus according to any one of the preceding claims, **characterised in** that the diameter of the axle/the cylinder part (4) and the turnable cylinder part (11) are essentially identical.
- 5
9. An apparatus for adjustment of the length of an infusion tubing (2) by means of an apparatus comprising a housing (3) with an axle/cylinder part (4) arranged about a centre axis, said housing (3) further comprising at least one turnable unit (6), **characterised in** that a first length of tubing is wound  
10 around the axle; that a second length of tubing (18) is wound around parts of the turnable unit; and that a first free end part (7) and a second free end part (8) are situated exteriorly of the housing.
10. A method according to claim 9, **characterised in** that the second end part is conveyed around a return wheel associated with the turnable unit and  
15 a turnable wheel/cylinder part.
11. A method according to claim 9 or 10; **characterised in** that tubing situated around the axle (4) is transferred to the turnable unit (6) and  
20 conversely during adjustment/unwinding of the length of the tubing.
12. A method according to claims 9-11, **characterised in** that the tubing is wound about the axle in a first direction and wound around parts of the turnable unit in a second direction opposite the first direction.  
25
13. Use of an apparatus according to claim 1-8 for exercising the method according to claims 9-12.
14. Use of an apparatus according to claims 1-8 for an infusion kit/infusion  
30 pump.

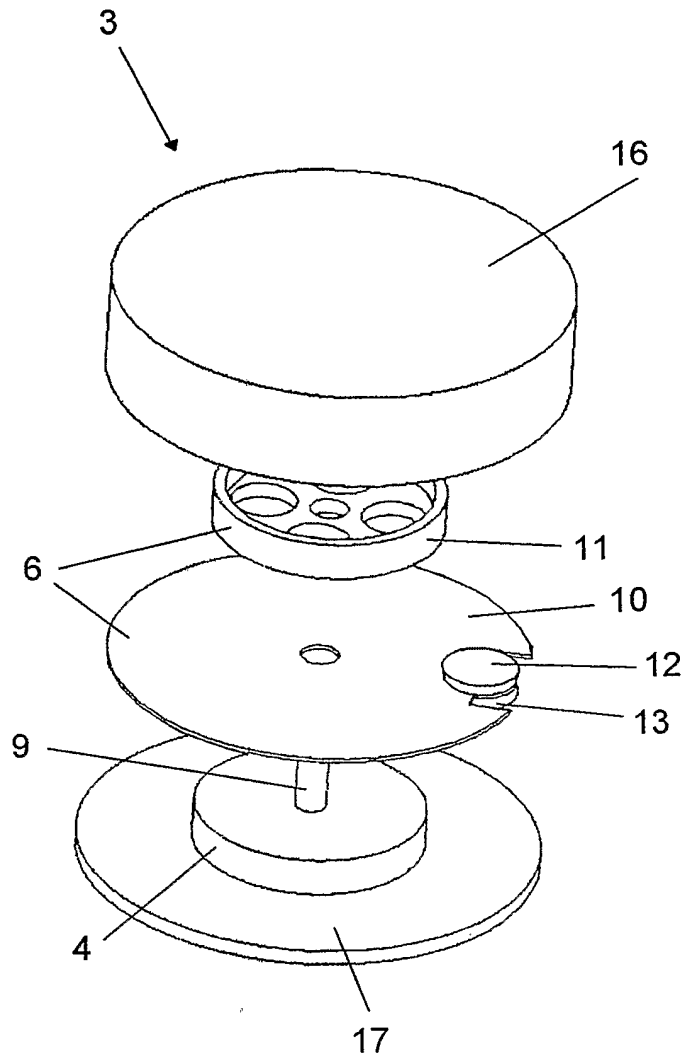

Fig. 1

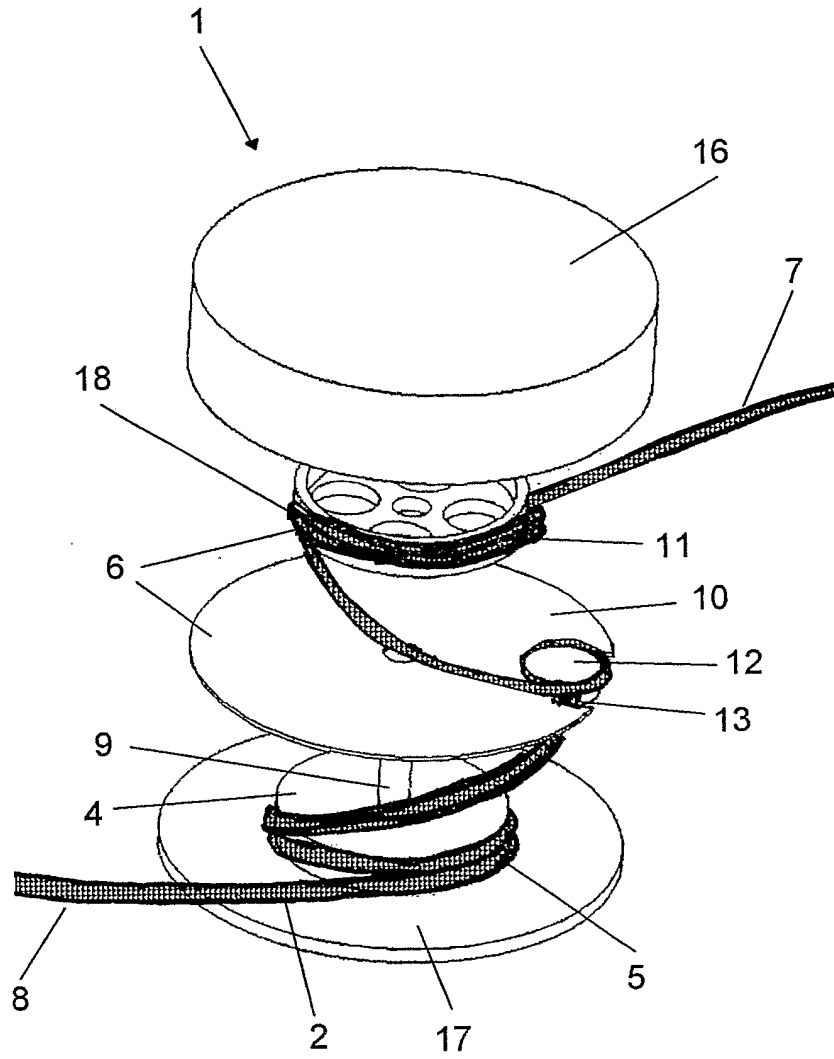

Fig. 2

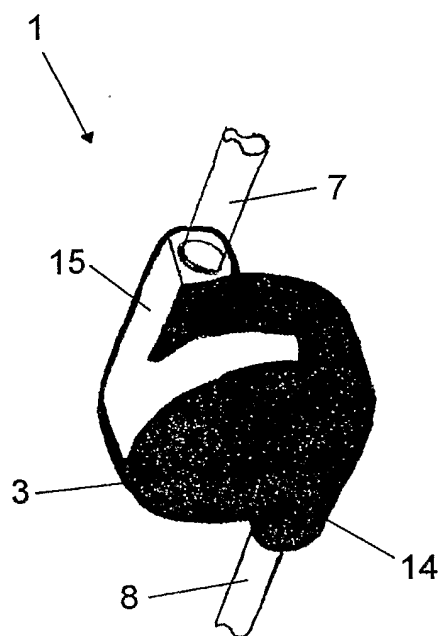

Fig. 3