



(12) EUROPEAN PATENT APPLICATION

(43) Date of publication:
12.04.2006 Bulletin 2006/15

(51) Int Cl.:
B65D 47/20 (2006.01) B65D 47/08 (2006.01)
B65D 47/24 (2006.01) B65D 51/24 (2006.01)

(21) Application number: 05019967.8

(22) Date of filing: 14.09.2005

(84) Designated Contracting States:
AT BE BG CH CY CZ DE DK EE ES FI FR GB GR
HU IE IS IT LI LT LU LV MC NL PL PT RO SE SI
SK TR
Designated Extension States:
AL BA HR MK YU

(71) Applicant: **The Procter and Gamble Company**
Cincinnati, Ohio 45202 (US)

(72) Inventor: **Etesse, Patrick Jean-Francois**
1040 Brussels (BE)

(30) Priority: 11.10.2004 EP 04077801

(74) Representative: **Goodier, Claire-Louise et al**
N.V.Procter & Gamble Services Company S.A.
Temselaan 100
1853 Strombeek-Bever (BE)

(54) **A top-up container assembly comprising a dispensing cap, and a dishwashing product comprised in the container assembly**

(57) The present invention relates to a top-up container assembly (1) comprising a bottle (20) having a bottom surface (22), and a top surface (21) having an opening located away from said bottom surface (22); and a dispensing cap (30) attached to said top surface (21) of said bottle (20), said dispensing cap (30) comprising a housing (31) and a valve (32), wherein at least a portion of said housing (31) is transparent and/or translucent, and wherein said valve (32) is visually distinctive from said housing (31), to enable a user of said top-up container assembly (1) to see the valve (32) through the housing (31). The present invention also relates to the use of a dispensing cap (30) for dispensing a dishwashing cleaning composition, to a dishwashing cleaning product, and to a method of cleaning dishware.

Fig. 1

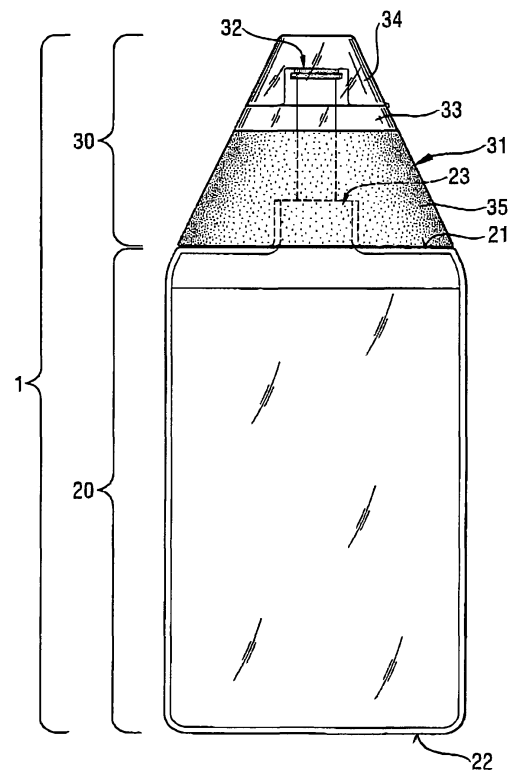

Description

FIELD OF THE INVENTION

[0001] The present invention relates to a top-up container assembly comprising a dispensing cap with a valve, and dishwashing cleaning products comprising the top-up container assembly.

BACKGROUND OF THE INVENTION

[0002] Plastic bottles comprising a spout for dispensing a liquid or a viscous composition are well known in the art, especially in the field of dishwashing cleaning products. These bottles are typically so-called "top-up" bottles. In order to dispense the composition, a user typically needs to open a cap to expose the spout, then invert and squeeze the bottle to dispense the composition. One problem with spouts is that, because of the spout's opening, the product flows out upon inversion of the bottle, even when the bottle is not squeezed. Another problem is that it is difficult to control the amount of product to be dispensed from the bottle. Another problem is mess. Bottles with spouts tend to leave product around the rim of the spout. As a result, the bottle does not only look messy, but the product also dries and forms a crust. If the crust is allowed to build up, then it eventually blocks the spout. All these problems lead to consumer dissatisfaction.

[0003] The use of valves (e.g. slit valves) for improved/controlled dispensing of a liquid or a viscous composition is also well known. Such valves are typically used in so-called "top-down" containers or tubes, which hold a liquid or viscous composition. Top-down containers or tubes are products which rest on their dispensing cap, when they are stored on a horizontal surface. One example is Ketchup™ products. Recently, and only for aesthetic reasons, colored, transparent or translucent dispensing caps comprising a valve have been developed. One company producing such dispensing caps is Seaquist Closures.

[0004] In the area of dishwashing, the use of valves for dispensing the composition is also known. For example, the product marketed under the name of Szezy from Buck chemicals, is a "top-down" container comprising a colored translucent cap with a slit valve (the valve not being visible through the cap). However, when in a certain type of "top-up" bottle which is typically marketed with a spout (such as most dishwashing products), the spout is replaced by a valve, a user may not readily notice the difference. A user may even believe the bottle is defective, as with valves, there is no visible opening. Also, squeeze-bottles equipped with a valve require a higher squeeze pressure for dispensing the composition, versus squeeze-bottles equipped with a spout. It is therefore important for a user to readily notice which type of product is being bought, or used (with spout or valve). The present invention overcomes these problems.

[0005] It is therefore an object of the invention to provide containers with a dispensing cap comprising a valve, which are easily distinguishable from containers with a dispensing cap comprising a spout.

[0006] It is another object of the present invention, to provide containers with a dispensing cap wherein the valve is always visible, even when the dispensing cap is in a closed state.

10 SUMMARY OF THE INVENTION

[0007] According to a first aspect, the present invention relates to a top-up container assembly (1) comprising a container (20) having a bottom surface (22), and a top surface (21) located away from said bottom surface (22), said top surface (21) having an opening (23); and a dispensing cap (30) attached to said top surface (21) of said bottle (20), said dispensing cap (30) comprising a housing (31) and a valve (32), wherein at least a portion of said housing (31) is transparent and/or translucent, and wherein said valve (32) is visually distinctive from said housing (31), to enable a user of said top-up container assembly (1) to see the valve (32) through the housing (31).

[0008] According to a second aspect, the present invention relates to the use of a dispensing cap (30) for dispensing a dishwashing cleaning composition.

[0009] According to a third aspect, the present invention relates to a dishwashing cleaning product.

[0010] According to a fourth aspect, the present invention relates to a method of cleaning dishware.

BRIEF DESCRIPTION OF THE DRAWINGS

35 **[0011]**

Fig. 1 shows a side view of a top-up container assembly according to the present invention.

Fig. 2 shows a side view of a dispensing cap according to the present invention.

Fig. 3 shows a side view of a another dispensing cap according to the present invention

Fig. 4 shows a top view of a dispensing cap according to the present invention.

45 DETAILED DESCRIPTION OF THE INVENTION

1. TOP-UP CONTAINER ASSEMBLY

[0012] In a first embodiment, the present invention relates to a top-up container assembly (1) comprising a container (20) and a dispensing cap (30). With "top-up", it is meant that the container assembly has a top and a bottom surface, at least a portion of said bottom surface being in contact with a horizontal flat surface when said container assembly is put on that horizontal flat surface. The top surface of the container assembly is located away from said bottom surface, and does not contact the

horizontal flat surface, when the container assembly is put on that horizontal surface.

[0013] The container (20) of the present invention may be a bottle or a stand-up pouch where the container is a bottle it is preferably a squeeze-bottle having flexible walls. The container has a bottom surface (22) and a top surface (21) located away from said bottom surface (22), and an opening (23) in said top surface (21). At least a portion of said bottom surface (22) is in contact with a horizontal flat surface when said container (20) is put on that horizontal flat surface. The container (20) useful herein has a hollow body for holding a liquid or gel composition, and is typically formed of plastic, preferably a polymer or resin such as polyethylene, polypropylene, polyethylene terephthalate, polycarbonate, polystyrene, ethyl vinyl alcohol, polyvinyl alcohol, thermoplastic elastomer, and combinations thereof, although other materials known in the art may also be used. Such containers (20) will typically hold from 100 mL to 2 L of liquid, preferably from 150 mL to 1.2 L of liquid, and more preferably from 200 mL to 1 L of liquid, and are well known for holding liquid consumer products. Such containers are widely available from many packaging suppliers.

[0014] By stand-up pouch it is meant that the container may be flexibly deformed, but that it is not resilient in the sense that it recovers its original shape when the deforming pressure is removed. Preferably such containers are formed from plastic film or films which are sealed together at the edge in order to form a closed container. The container is provided with an opening which is sealed around the closure. Most preferably the plastic film is made from polyethylene, polypropylene, polyester or laminate thereof and has a thickness of from 50 to 250 micrometers.

[0015] A dispensing cap (30) is attached to the top surface (21) of the bottle (20). The dispensing cap (30) may be formed as either integral with, or separate from the bottle (20). If formed separately, the dispensing cap (30) may attach to the bottle (20) via methods known in the art such as by employing a transition piece, corresponding threaded male and female members, pressurized and non-pressurized seals, locking and snap-on parts, and/or other methods known in the art. Preferably, the dispensing cap (30) is attached to the bottle (20) via a transition piece and/or with corresponding threaded male and female members which allow easy refilling. The dispensing cap (30) comprises a housing (31), and a valve (32).

[0016] The housing (31) preferably comprises a body (33), and a closing lid (34) which is hinged along an axis (A) to said body (33). The body (33) comprises an opening into which the valve (32) can be fitted in a leak-tight manner. Preferably, the body (33) further comprises a ring (36) which fits into the body's (33) opening, wherein the valve (32) can be fitted in a leak-tight manner. The dispensing cap (30) may further comprise a collar (35) which surrounds the bottom (22) portion of the housing (31) or the body (33). The housing (31), body (33), closing lid (34), ring (36) and collar (35) are typically formed of plastic, preferably a polymer or resin such as polyethyl-

ene, polypropylene, polyethylene terephthalate, polycarbonate, polystyrene, ethyl vinyl alcohol, polyvinyl alcohol, thermoplastic elastomer, and combinations thereof, although other materials known in the art may also be used.

Most preferably, they are formed of polypropylene.

[0017] The preferred valve (32) is a slit valve (32) having a pair of slits (37) intersecting at the center of the valve (32). Although one pair of slits (37) is preferred, more slits (37) may be present. The valve (32) is preferably formed of silicone or a thermoplastic elastomer. When the bottle (20) is squeezed, the valve (32) opens when the pressure differential across the valve (32) exceeds a predetermined amount (e.g. when the container assembly's (1) interior pressure increases to a predetermined amount relative to standard atmospheric pressure outside the container assembly (1)). The valve (32) may be formed as a unitary part of the dispensing cap (30), or may be mounted in a separate assembly (e.g. a ring (36) as described hereinabove) that is permanently or releasably attached to the dispensing cap (30). Suitable valves for the dispensing cap (30) of the present invention, are readily available on the market, e.g. from Seaquist Closures.

[0018] An essential aspect of the present invention is that at least a portion of the housing (31) is transparent and/or translucent, and that the valve (32) is visually distinctive from the housing (31). With this, it is meant that the valve (32) can be seen through at least a portion of the housing (31), either from the side, from the top, or both. This includes that the valve (32) may be seen either only through a portion of the closing lid (34) (from the side, from the top, or both), or only through the side of at least a portion of the dispensing cap's (1) body (33), or both. This also includes that the valve (32) may be seen through the entire housing (31) from the side and from the top. This also includes that the valve (32) is clearly visible through the housing (31), or that a user can see a haze of different shades and/or colors (valve versus housing), whereby the user is able to distinguish the valve (32) from the housing (31). This also enables a user to easily distinguish dispensing caps having a valve (32) from dispensing caps having a spout. Preferably at least 5%, more preferably at least 10%, even more preferably at least 20%, and up to 100% of the housing (31) material is transparent and/or translucent. When the housing (31) comprises a body (33) and a closing lid (34), preferably at least 5%, more preferably at least 10%, even more preferably at least 20%, and up to 100% of the body (33) and/or closing lid (34) material is transparent and/or translucent. If a ring (36), as described above, is used in the housing (31), it is preferred that the ring (36) is entirely transparent and/or translucent. The valve (32) is preferably not transparent nor translucent.

[0019] In order to improve the visual distinctiveness, it is preferred that the valve (32) is of a different color, more preferably of a contrasting color than the housing (31), body (33) or closing lid (34). Preferably, the valve (32) is colored while the housing (31), body (33) or closing lid

(34), are not colored.

[0020] When the dispensing cap (30) comprises a collar (35), it is preferred that the collar (35) is visually distinctive from the housing (31). Preferably the collar (35) is not transparent, nor translucent, and of a different color, preferably of a contrasting color than the housing (31), body (33) or closing lid (34). Most preferably, the collar (35) is in the same color as the valve (32).

[0021] With transparent or translucent, it is meant that the material has a light transmission of at least 35% in the visible spectrum (from 400 nanometers in the violet to 700 nanometers in the red end of the visible spectrum). The light transmission of a material can be measured using commercially available hazemeters or spectrophotometers. One test method for measuring the light transmission of a material, is described in Standard Test Method D-1003 (ASTM D-1003) from the American Society for Testing and Materials. In this test method, a unidirectional perpendicular light beam is directed onto the material, and a photo detector measures the total light transmitted by the specimen after it enters an integrating sphere.

2. DISHWASHING CLEANING PRODUCT

[0022] In a second embodiment, the present invention relates to the use of the dispensing cap (30) described hereinabove, for dispensing a dishwashing cleaning composition. In a third embodiment, the present invention relates to a dishwashing cleaning product comprising the container assembly (1) described hereinabove, and a dishwashing cleaning composition contained in the top-up container assembly (1).

[0023] The dishwashing cleaning composition can be in the form of a liquid or a gel, and typically includes also a solvent, and preferably one or more optional ingredients known in the art of dishwashing, such as enzymes, viscosity modifiers, diamines, carboxylic acids, polymeric suds stabilizers, builders, magnesium ions, chelating agents, hydrophobic block polymers, or organic and inorganic salts. The dishwashing cleaning composition will further preferably comprise one or more detergent adjuncts selected from the following: soil release polymers, polymeric dispersants, polysaccharides, abrasives, bactericides and other antimicrobials, tarnish inhibitors, dyes or pigments, buffers, antifungal or mildew control agents, insect repellents, perfumes, hydrotropes, thickeners, processing aids, suds boosters, brighteners, anti-corrosive aids, stabilizers, antioxidants, a pH controlling agent, a reducing or oxidizing bleach, an odor control agent, antioxidants and free radical inhibitors, and a mixture thereof.

The dishwashing cleaning product will further preferably comprise instructions for using the dishwashing cleaning product.

3. METHOD OF CLEANING DISHWARE

[0024] In a fourth embodiment, the present invention also relates to a method of cleaning dishware, using the dishwashing cleaning product described hereinabove. The method comprises at least the steps of inverting the dishwashing cleaning product, and then squeezing the bottle (20) such that the valve (32) opens and the dishwashing cleaning composition is dispensed from the top-up container assembly (1).

[0025] The composition may be applied to the dishware neat or in dilute form. Thus the dishware may be cleaned singly by applying the composition to the dishware and optionally but preferably subsequently rinsing before drying. Alternatively, the composition can be mixed with water in a suitable vessel, for example a basin, sink or bowl and thus a number of dishes can be cleaned using the same composition and water (dishwater). In a further alternative process the product can be used in dilute form in a suitable vessel as a soaking medium for, typically extremely dirty, dishware. As before the dishware can be optionally, although preferably, rinsed before allowing to dry. Drying may take place passively by allowing for the natural evaporation of water or actively using any suitable drying equipment, for example a cloth or towel.

Claims

1. A top-up container assembly (1) comprising:

- a container (20) having a bottom surface (22), and a top surface (21) located away from said bottom surface (22), said top surface having an opening (23); and
- a dispensing cap (30) attached to said top surface (21) of said container (20), said dispensing cap (30) comprising a housing (31) and a valve (32),

characterized in that at least a portion of said housing (31) is transparent and/or translucent, and said valve (32) is visually distinctive from said housing (31), to enable a user of said top-up container assembly (1) to see the valve (32) through the housing (31).

2. A top-up container assembly according to claim 1, wherein the container is selected from a bottle or a stand-up pouch.

3. The top-up container assembly (1) according to any preceding claim, wherein said housing (31) comprises a body (33), and a closing lid (34), said closing lid (34) being hinged along an axis (A) to said body (33), wherein:

- at least a portion of said closing lid (34) is transparent and/or translucent, to enable a user of said top-up container assembly (1) to see the valve (32) through said closing lid (34) when said closing lid (34) is closing said dispensing cap (30); and/or
- at least a portion of said body (33) is transparent and/or translucent, to enable a user of said top-up container assembly (1) to see the valve (32) through said body (33).
4. The top-up container assembly (1) according to any preceding claim, wherein 5% to 100% of the dispensing cap (30) material is transparent and/or translucent.
5. The top-up container assembly (1) according to any preceding claim, wherein
- 5% to 100% of the closing lid (34) material is transparent and/or translucent; and/or
- 5% to 100% of the body (33) material is transparent and/or translucent.
6. The top-up container assembly (1) according to any preceding claim, wherein said valve (32) is a slit valve (32).
7. The top-up container assembly (1) according to any preceding claim, wherein said valve (32) and said housing (31) are of a different color.
8. The top-up container assembly (1) according to claims 3-7, wherein said valve (32) and said closing lid (34) are of a different color.
9. The top-up container assembly (1) according to claims 3-8, wherein said valve (32) and said body (33) are of a different color.
10. The top-up container assembly (1) according to any preceding claim, wherein said dispensing cap (30) further comprises a transparent and/or translucent ring (36) wherein the valve (32) is positioned.
11. The top-up container assembly (1) according to claims 3-10, wherein the dispensing cap (30) further comprises a collar (35) around said body (33), said collar (35) being visually distinctive from said housing (31),
12. The top-up container assembly (1) according to claim 11, wherein the collar (35) and the valve (32) are of the same color.
13. A dishwashing cleaning product comprising:
- a top-up container assembly (1) according to
- any preceding claim, and
- a dishwashing cleaning composition contained in said top-up container assembly (1).
14. A dishwashing cleaning product according to claim 13, wherein said product further comprises instructions for use.
15. A method of cleaning dishware with the dishwashing cleaning product of claims 13-14, said method comprising the steps of:
- inverting the dishwashing cleaning product; and
- squeezing the bottle (20) to open the valve (32), and to dispense the dishwashing cleaning composition from the top-up container assembly (1).
16. Use of a dispensing cap (30) comprising a housing (31) and a valve (32), at least a portion of said housing (31) being transparent and/or translucent, and the valve (32) being visually distinctive from said housing (31), to enable a user of said dispensing cap (30) to see the valve (32) through the housing (31), for dispensing a dishwashing cleaning composition.
17. The use according to claim 16, wherein said housing (31) comprises a body (33), and a closing lid (34), said closing lid (34) being hinged along an axis (A) to said body (33), wherein
- at least a portion of said closing lid (34) is transparent and/or translucent, to enable a user of said top-up container assembly (1) to see the valve (32) through said closing lid (34) when said closing lid (34) is closing the dispensing cap (30); and/or
- at least a portion of said body (33) is transparent and/or translucent, to enable a user of said top-up container assembly (1) to see the valve (32) through said body (33).
18. The use according to claims 16-17, wherein 5% to 100% of the housing (31) material is transparent and/or translucent.
19. The use according to claims 17-18, wherein
- 5% to 100% of the closing lid (34) material is transparent and/or translucent; and/or
- 5% to 100% of the body (33) material is transparent and/or translucent.
20. The use according to claims 16-19, wherein said valve (32) is a slit valve (32).
21. The use according to claims 16-20, wherein said valve (32) and said housing (31) are of a different

color.

- 22.** The use according to claims 17-21, wherein said valve (32) and said closing lid (34) are of a different color. 5
- 23.** The use according to claims 17-22, wherein said valve (32) and said body (33) are of a different color.
- 24.** The use according to claims 16-23, wherein said dispensing cap (30) further comprises a transparent and/or translucent ring (36) wherein the valve (32) is positioned. 10
- 25.** The use according to claims 16-24, wherein the dispensing cap (30) further comprises a collar (35) around the body (33), said collar (35) being visually distinctive from said housing (31). 15
- 26.** The use according to claim 25, wherein the collar (35) and the valve (32) are of the same color. 20

25

30

35

40

45

50

55

Fig. 1

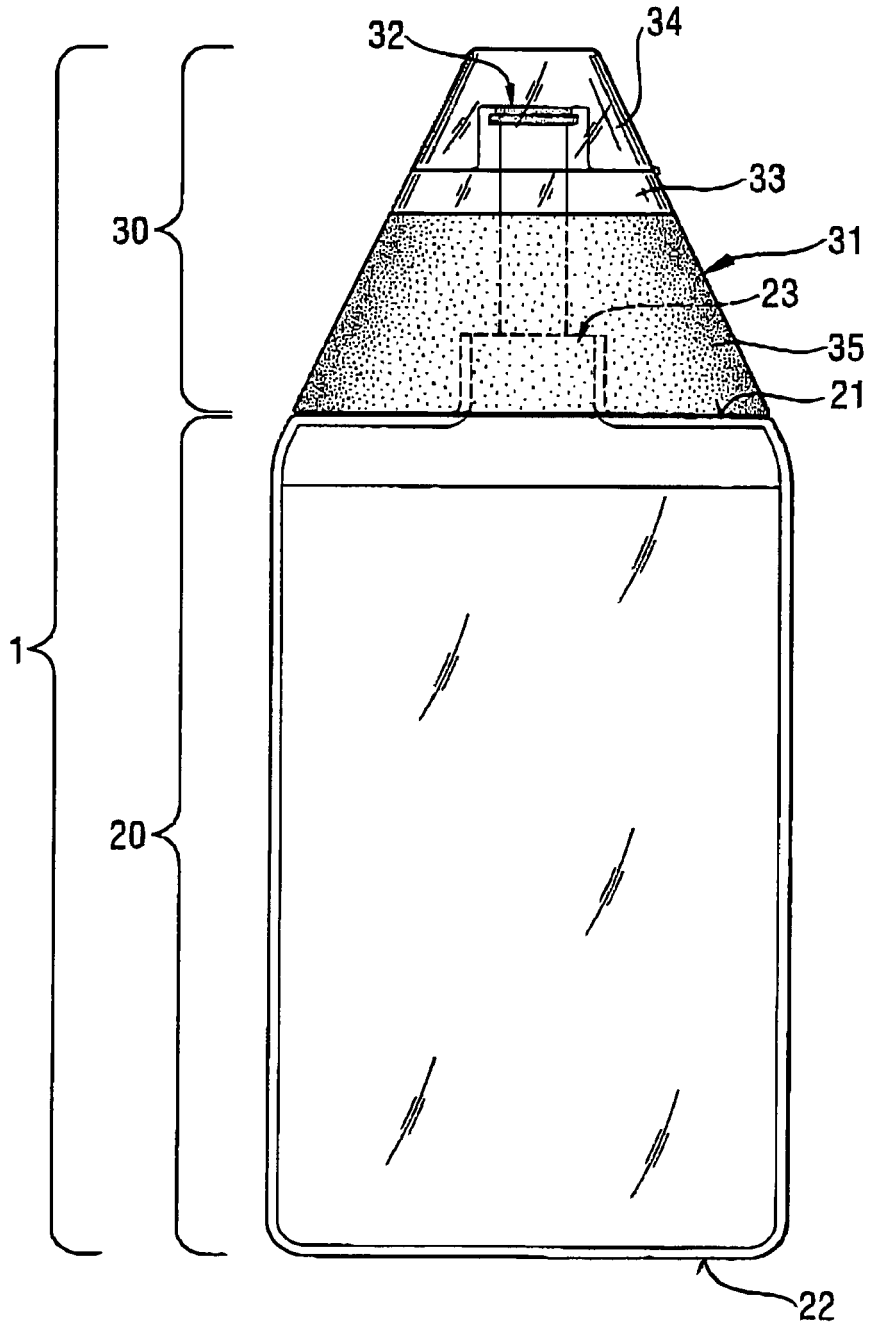

Fig. 2

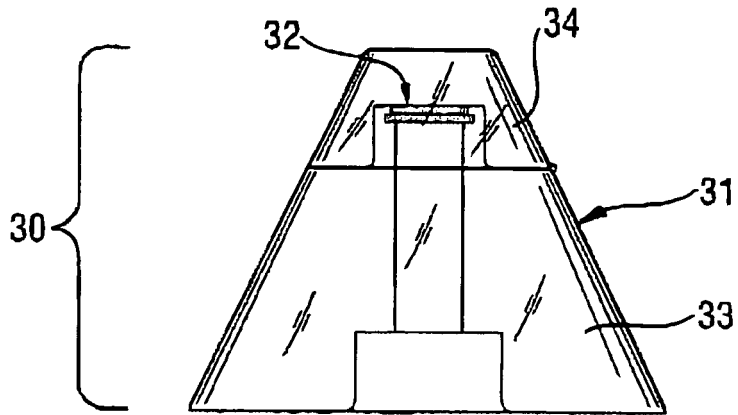

Fig. 3

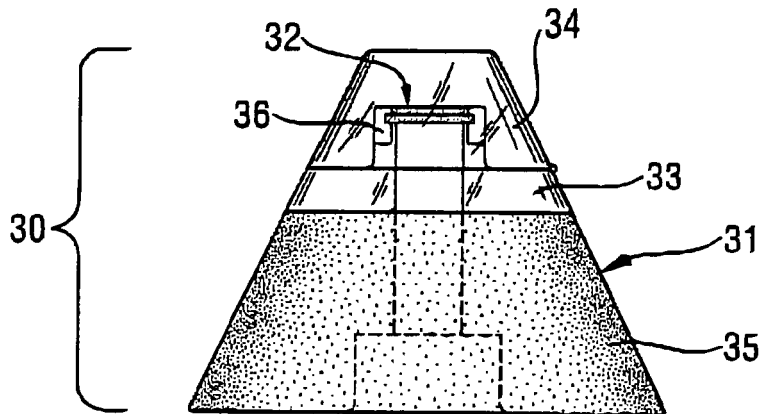
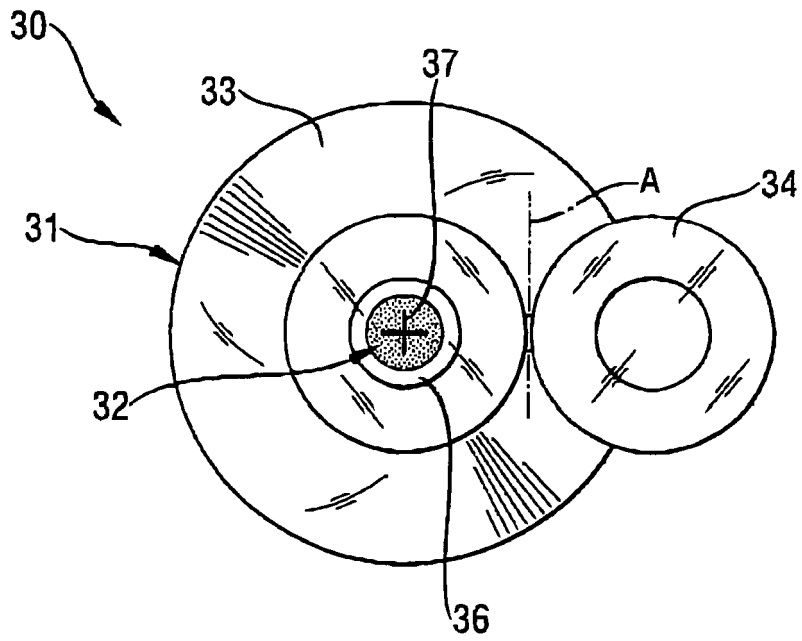

Fig. 4





DOCUMENTS CONSIDERED TO BE RELEVANT			
Category	Citation of document with indication, where appropriate, of relevant passages	Relevant to claim	CLASSIFICATION OF THE APPLICATION (IPC)
X	US 5 033 655 A (BROWN ET AL) 23 July 1991 (1991-07-23) * column 8, line 18 - column 12, line 14; figures 1-13 *	1-26	B65D47/20 B65D47/08 B65D47/24 B65D51/24
X	GB 1 474 620 A (BLENDAX WERKE SCHNEIDER R GMBH CO) 25 May 1977 (1977-05-25) * page 2, line 30 - page 3, line 11; figures 1-6 *	1,2, 5-16,20, 21,24-26	
A	US 6 672 487 B1 (LOHRMAN RICHARD D) 6 January 2004 (2004-01-06) * column 2, line 58 - column 6, line 24; figures 1-12 *	1-26	
A	EP 0 885 813 A (YOSHINO KOGYOSHO CO., LTD; KAO CORPORATION) 23 December 1998 (1998-12-23) * column 4, line 28 - column 6, line 27; figures 1,2a *	1-26	
			TECHNICAL FIELDS SEARCHED (IPC)
			B65D
The present search report has been drawn up for all claims			
Place of search Munich		Date of completion of the search 8 November 2005	Examiner Cazacu, C
<p>CATEGORY OF CITED DOCUMENTS</p> <p>X : particularly relevant if taken alone Y : particularly relevant if combined with another document of the same category A : technological background O : non-written disclosure P : intermediate document</p> <p>T : theory or principle underlying the invention E : earlier patent document, but published on, or after the filing date D : document cited in the application L : document cited for other reasons & : member of the same patent family, corresponding document</p>			

2
EPO FORM 1503 03.82 (F04C01)

**ANNEX TO THE EUROPEAN SEARCH REPORT
ON EUROPEAN PATENT APPLICATION NO.**

EP 05 01 9967

This annex lists the patent family members relating to the patent documents cited in the above-mentioned European search report. The members are as contained in the European Patent Office EDP file on
The European Patent Office is in no way liable for these particulars which are merely given for the purpose of information.

08-11-2005

Patent document cited in search report		Publication date	Patent family member(s)	Publication date
US 5033655	A	23-07-1991	NONE	
GB 1474620	A	25-05-1977	NONE	
US 6672487	B1	06-01-2004	US 6786363 B1	07-09-2004
EP 0885813	A	23-12-1998	CN 1206677 A	03-02-1999
			DE 69801955 D1	15-11-2001
			DE 69801955 T2	04-04-2002
			JP 3523021 B2	26-04-2004
			JP 11009489 A	19-01-1999
			US 5897033 A	27-04-1999