



Office de la Propriété  
Intellectuelle  
du Canada

Un organisme  
d'Industrie Canada

Canadian  
Intellectual Property  
Office

An agency of  
Industry Canada

CA 2364486 C 2008/06/17

(11)(21) **2 364 486**

(12) **BREVET CANADIEN  
CANADIAN PATENT**

(13) **C**

(86) Date de dépôt PCT/PCT Filing Date: 2000/03/09  
 (87) Date publication PCT/PCT Publication Date: 2000/09/14  
 (45) Date de délivrance/Issue Date: 2008/06/17  
 (85) Entrée phase nationale/National Entry: 2001/08/30  
 (86) N° demande PCT/PCT Application No.: US 2000/006175  
 (87) N° publication PCT/PCT Publication No.: 2000/054487  
 (30) Priorité/Priority: 1999/03/11 (US09/266,477)

(51) Cl.Int./Int.Cl. *H04M 1/57* (2006.01),  
*H04L 12/54* (2006.01), *H04M 11/06* (2006.01),  
*H04M 3/533* (2006.01)

(72) Inventeurs/Inventors:  
 RAMEY, BLAINE EDWARD, US;  
 CAFFREY, JOHN JUSTIN, US;  
 WANG, MINGHENG, US

(73) Propriétaire/Owner:  
 THOMSON LICENSING S.A., FR

(74) Agent: CRAIG WILSON AND COMPANY

**SECTION 8 CORRECTION**  
 SEE CERTIFICATE  
 CORRECTION ARTICLE 6  
 VOIR CERTIFICAT

(54) Titre : REPERTOIRE UNIFIE D'IDENTIFICATEURS D'APPELANTS ET D'ADRESSES DE COURRIER  
 ELECTRONIQUE

(54) Title: UNIFIED DIRECTORY FOR CALLER ID AND ELECTRONIC MAIL ADDRESSES

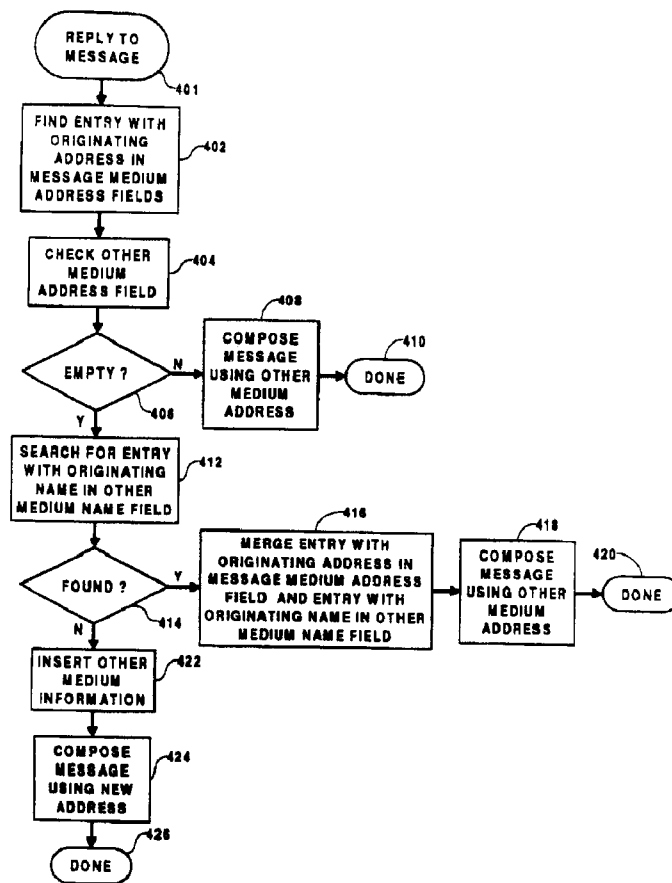

(57) Abrégé/Abstract:

A method and system for message communications in different media. A first message is received via a first communications medium. First address information associated with the first communications medium is extracting from the first communications



**(57) Abrégé(suite)/Abstract(continued):**

medium. Second address information associated with a second communications medium is determined automatically in response to the first address information. A reply for the first message is sent via the second communications medium using the second address information.



Office de la propriété  
intellectuelle  
du Canada

Un organisme  
d'Industrie Canada

Canadian  
Intellectual Property  
Office

An Agency of  
Industry Canada

*Bureau canadien  
des brevets  
Certificat de correction*

*Canadian Patent  
Office  
Certificate of Correction*

Canadian Patent No. 2,364,486  
Granted: June 17, 2008

Les corrections suivantes sont faites en  
raison de l'article 8 de la *Loi sur les  
brevets* et le document doit être lu tel  
que corrigé.

The following corrections are made  
pursuant to section 8 of the *Patent Act*  
and the document should read as  
corrected.

In the Patent Grant:

1. The name of the first inventor has been corrected to read:

**RAMEY, BLAINE EDWARD**

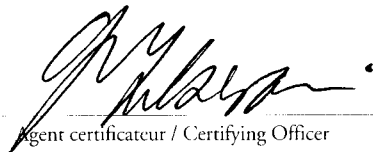
  
Agent certificateur / Certifying Officer

October 7, 2008

Date

Canada

(CIPO 25)  
01/07/05

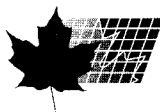
OPIC  CIPO



PCT

WORLD INTELLECTUAL PROPERTY ORGANIZATION  
International Bureau

## INTERNATIONAL APPLICATION PUBLISHED UNDER THE PATENT COOPERATION TREATY (PCT)

<b>(51) International Patent Classification <sup>7</sup> :</b> <b>H04M 7/00, 3/533</b>	<b>A1</b>	<b>(11) International Publication Number:</b> <b>WO 00/54487</b> <b>(43) International Publication Date:</b> 14 September 2000 (14.09.00)
<b>(21) International Application Number:</b> PCT/US00/06175 <b>(22) International Filing Date:</b> 9 March 2000 (09.03.00) <b>(30) Priority Data:</b> 09/266,477                      11 March 1999 (11.03.99)                      US <b>(71) Applicant (for all designated States except US):</b> THOMSON LICENSING S.A. [FR/FR]; 46, Quai A. Le Gallo, F-92648 Boulogne Cedex (FR). <b>(72) Inventors; and</b> <b>(75) Inventors/Applicants (for US only):</b> RAMEY, Blaine, Edward [US/US]; 6617 N. Oakland Avenue, Indianapolis, IN 46220 (US). CAFFREY, John, Justin [US/US]; 2716 Canterbury Lane, Indianapolis, IN 46220-2241 (US). WANG, Mingheng [CN/US]; 3523 N. Dukane Way, Indianapolis, IN 46224 (US). <b>(74) Agents:</b> TRIPOLI, Joseph, S. et al.; Thomson Multimedia Licensing Inc., P.O. Box 5312, Princeton, NJ 08540 (US).	<b>(81) Designated States:</b> AE, AL, AM, AT, AU, AZ, BA, BB, BG, BR, BY, CA, CH, CN, CR, CU, CZ, DE, DK, DM, EE, ES, FI, GB, GD, GE, GH, GM, HR, HU, ID, IL, IN, IS, JP, KE, KG, KP, KR, KZ, LC, LK, LR, LS, LT, LU, LV, MA, MD, MG, MK, MN, MW, MX, NO, NZ, PL, PT, RO, RU, SD, SE, SG, SI, SK, SL, TJ, TM, TR, TT, TZ, UA, UG, US, UZ, VN, YU, ZA, ZW, ARIPO patent (GH, GM, KE, LS, MW, SD, SL, SZ, TZ, UG, ZW), Eurasian patent (AM, AZ, BY, KG, KZ, MD, RU, TJ, TM), European patent (AT, BE, CH, CY, DE, DK, ES, FI, FR, GB, GR, IE, IT, LU, MC, NL, PT, SE), OAPI patent (BF, BJ, CF, CG, CI, CM, GA, GN, GW, ML, MR, NE, SN, TD, TG).  <b>Published</b> <i>With international search report.</i> <i>Before the expiration of the time limit for amending the claims and to be republished in the event of the receipt of amendments.</i>	

**(54) Title:** UNIFIED DIRECTORY FOR CALLER ID AND ELECTRONIC MAIL ADDRESSES**(57) Abstract**

A method and system for message communications in different media. A first message is received via a first communications medium. First address information associated with the first communications medium is extracting from the first communications medium. Second address information associated with a second communications medium is determined automatically in response to the first address information. A reply for the first message is sent via the second communications medium using the second address information.

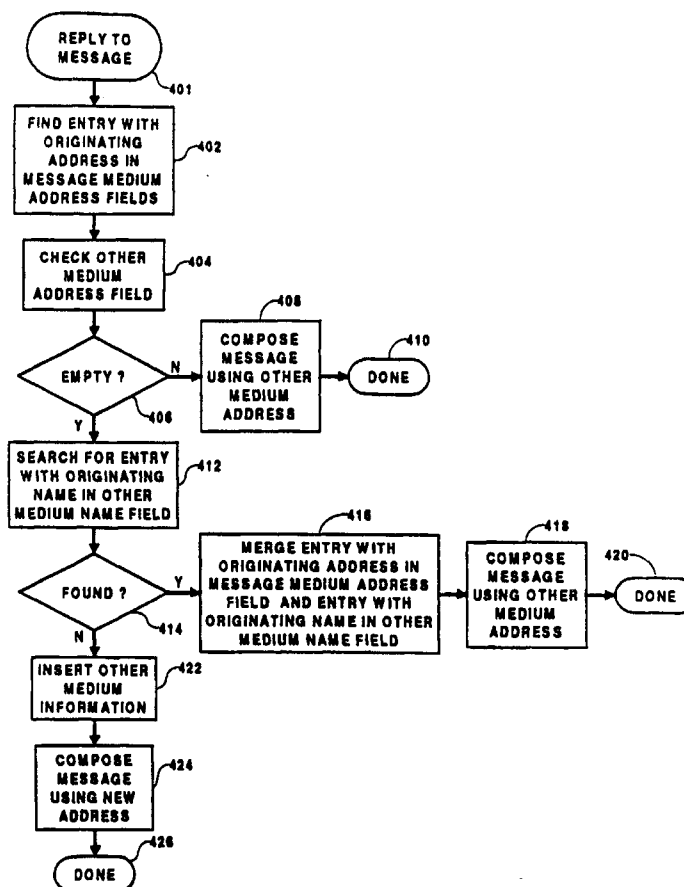

UNIFIED DIRECTORY FOR CALLER ID AND ELECTRONIC MAIL  
ADDRESSES

The present invention relates to a communication device able  
10 to communicate in more than one communications medium, and in  
particular to a communication device with interaction  
between the communications media.

One such communications medium is telephone. Telephone  
instruments with caller ID capabilities have been in use for  
15 some time. When such instruments receive a telephone call,  
they also receive the telephone number of the calling telephone  
and the name of the person owning the calling telephone. The  
telephone number and/or name may be displayed when the  
telephone call is received. The subscriber can then know the  
20 person making the call, and prepare for the conversation or not  
answer the call at all.

The caller ID capabilities are often combined with  
answering machine capabilities, a combination termed voice  
mail. Should the intended recipient be unable to receive a  
25 telephone call, the caller records a message, which may be  
retrieved later by the subscriber. The caller ID information  
is associated with the recorded message, and also stored.  
Should the subscriber wish to return the telephone call, the  
associated caller ID information is retrieved and allows the  
30 call to be automatically placed to the originating telephone  
number.

5 Another such communications medium is electronic mail (e-mail). Electronic mail communications devices have also been  
in use for some time. Such devices are coupled to a communica-  
10 tions network, and have the capability of receiving e-mail  
messages from others also connected to that communications  
network. In its most basic form, e-mail messages are textual  
in nature, and are generally typed at a alphanumeric keyboard  
by the originator. The recipient can read the message on an  
alphanumeric display. Extensions to the basic e-mail system  
15 permit inclusion of, for example, sound files, image files, or  
other data files which may be seen in-line or processed as  
separate attachments. The message is packaged in an electronic  
envelope, which is sent, via the communications network, to the  
recipient. The envelope includes, among other things, the e-  
mail address of the recipient, the e-mail address of the  
20 originator, and the e-mail name of the originator.

In general, e-mail messages for a subscriber are stored in  
a system coupled to the communications network termed a mail  
box or mail server. When the subscriber wishes, the mail box  
is accessed from the e-mail device and the accumulated e-mail  
25 messages forwarded to the recipient and read. The information  
from the envelope, including the originating e-mail address and  
e-mail name, is retrieved along with the message. Should the  
recipient wish to reply to the e-mail message, the retrieved  
recipient e-mail address from the envelope allows the return e-  
30 mail to be addressed automatically.

Systems for accessing messages in various communications  
media in an integrated manner have also been described in the

5 art. U.S. Patent 4,612,416, issued September 16, 1986 to Emerson et al., illustrates a PBX system including different communications functions for corresponding communications media (i.e. voice mail, e-mail, facsimile, etc.). When a subscriber checks any message function, all can be checked, and the user  
10 switched transparently to which ever function contains a message to be retrieved.

U.S. Patent 4,837,798, issued June 6, 1989 to Cohen et al., illustrates a communications system including a centralized, unified repository for received messages in any  
15 communications medium, including voice mail, e-mail, and any other media such as facsimile. The central location receives notification of each message received, and then notifies the recipient of the receipt of the message. The centralized repository also performs conversion of the message from one  
20 medium to another (for example, from e-mail to voice mail via text-to-voice generation) to the extent possible to permit the recipient to retrieve all messages in whatever medium desired.

U.S. Patent 5,239,577 issued August 24, 1993 to Bates et al. illustrates a telephone system in which all telephone  
25 numbers (for example, home, home fax, business, business fax, mobile, etc.) for an individual are accessible through a publically available, centrally located, directory of directories for that individual. A call intended for one of the telephone numbers may be completed by specifying another  
30 telephone number (e.g. home telephone), and requesting the desired other number (e.g. business telephone). The desired telephone number is found by consulting the centrally located

5 directory of directories, and then the directory containing  
that individual's business telephone number.

U.S. Patent 5,557,659, issued September 17, 1996 to Hyde-  
Thomson, illustrates a system in which the e-mail communications  
medium is used for both e-mail and voice mail. Voice mail  
10 messages are converted to sound files and attached to e-mail  
messages which are, in turn, sent to the e-mail device of the  
subscriber.

U.S. Patent 5,647,002, issued July 8, 1997 to Brunson,  
illustrates a system in which each different communication  
15 medium (i.e. voice mail, e-mail, facsimile, etc.) has it's own  
message reception center (i.e. mail box), in the usual manner.  
Each message is duplicated when it is received, to the extent  
possible, and sent to the reception centers of each of the  
other communications media. Each reception center is coupled  
20 to a synchronizer which maintains all of the mail boxes in  
synchronism.

U.S. Patent 5,671,269, issued September 23, 1997 to Egan  
et al., illustrates a personal computer based telephone system  
in which a telephone number, derived in any of a number of  
25 different ways, is associated with each incoming telephone  
call, and if a return phone call is desired, the associated  
telephone number is used to place the return call.

U.S. Patent 5,692,038, issued November 25, 1997 to Kraus  
et al. illustrates a centrally controlled communications system  
30 involving several communications media in which a personal  
identification number is assigned to an individual, and each  
telephone number (or other identification such as e-mail



Address) associated with that individual is searched in an order set by the individual when that individual receives a message.

In addition, software products available at this time maintain a unified mail box for messages from different communications media.

5 For example, Microsoft Outlook e-mail client maintains a single mail box containing both e-mail and facsimile messages.

It may, however, be desirable that a received voice mail message be replied to with an e-mail message, or vice versa. For example, a phone request for a document is best answered with an e-mail message  
10 to which the desired document is attached. Similarly, an e-mail message containing a document for which approval is sought may be best answered with a telephone call giving that approval. However, none of the above systems extract information associated with a message received in one communications medium and use that information to  
15 permit a user to reply to that message using a different communication medium.

WO 98/23058 discloses a system for integrated management of messaging and communications over the internet. The document describes a system which allows a user to respond to a communication  
20 in one medium with another. The document, however, requires or assumes that the address information required for replying in a different medium has already been entered by the user. Furthermore the document does not describe what happen when the reply address has not been entered by the user.

25 In accordance with principles of the present invention, a method and system for messages communications in different media is disclosed. A first message is received via a first communications medium. First address information associated with the first communications medium is extracting from the first communications

5/1

**medium. Second address information associated with a second communications medium is determined automatically in response to the first address information. A reply for the first message is sent**

**AMENDED SHEET**

FMPFANGSZEIT 11 JUN 22.16

ABERDRECKSZEIT 12 JUN 7.20

6

5 via the second communications medium using the second address information.

Also in accordance with principles of the present invention, a method for automatically providing a destination address for a reply in a first communications medium to a message received  
10 from an originating address and an originating name in a second communications medium comprises the following steps. A correspondent data base contains a plurality of entries, each entry representing a correspondent and containing an address field and a name field for messages in the first communications  
15 medium, and an address field and a name field for messages in the second communications medium. This data base is searched for a first entry containing the originating address in the address field for messages in the second communications medium. If the first entry contains an address in the address field for  
20 messages in the first communications medium, that address is provided as the destination address. If the first entry does not contain an address in the address field for messages in the first communications medium, the correspondent data base is searched for a second entry having a name in the name field for  
25 messages in the first communications medium corresponding to the originating name. If a second entry is found, the contents of the address field for messages in the first communications medium in the second entry is provided as the destination address and the first and second entries are merged. If a  
30 second entry is not found, an address is requested from a user. The first entry is updated by storing the user-supplied address in the address field for messages in the first communications

7

5 medium and the originating name is saved in the name field for messages in the first communications medium. The user-supplied address is provided as the destination address.

A communications device according to the invention permits a user to easily reply to an incoming message in any  
10 communications medium by a reply message in whatever communications media is most convenient, regardless of which communications medium was used to send the incoming message.

In the drawing:

Fig. 1 is a block diagram of a communications device  
15 according to the present invention;

Fig. 2 is a table describing the structure and contents of a database used in the communications device illustrated in Fig. 1;

Fig. 3 is a flow diagram illustrating the method for  
20 inserting information into the database illustrated in Fig. 2; and

Fig. 4 is a flow diagram illustrating the method for supplying a reply address in one communications medium to a message received in the other communications medium.

25 Fig. 1 is a block diagram of a communications device 10 according to the present invention. In Fig. 1, a subscriber telephone line is coupled to an bi-directional terminal 5.

Terminal 5 may, for example, be an easy-connect RJ11 type connector. Terminal 5 is bidirectionally coupled to a  
30 processor 110 through a serial connection of a line interface circuit 102, a multiplexer (MUX) 104, a coder/decoder (codec) 106 and a digital signal processor (DSP) 108. An output

8

5 terminal of the multiplexer 104 is coupled to an input terminal of a speaker 112 and an output terminal of a microphone 114 is coupled to an input terminal of the multiplexer 104.

An output terminal of a keyboard 116 is coupled to an input terminal of the processor 110 and an output terminal of  
10 the processor 110 is coupled to an input terminal of a display device 118. A bi-directional terminal of the processor 110 is coupled to a serial port 120, and an output terminal of the processor 110 is coupled to an output port 122 to which a printer may be connected. An output terminal of a non-volatile  
15 read-only memory (ROM) 124 is coupled to an input terminal of the processor 110 and a bi-directional terminal of a read/write random access memory (RAM) 126 is coupled to a corresponding terminal of the processor 110.

In operation, the processor 110 controls the operation of  
20 the communications device 10. The processor reads and executes the stored program code in the ROM 124, accesses constants in the ROM 124 and reads and writes variable data from and to the RAM 126. Further the processor exchanges data with the various input/output (I/O) ports: the serial port 120, the printer port  
25 122, the keyboard 116, the display device 118, and the telephone line port coupled to the DSP 108, all in a known manner. Images are displayed on the display device 118 to provide information to the user, and depression of the keys on the keyboard 116 are detected to accept information from the  
30 user. A least some of the keys in the keyboard 116 are physically adjacent to the display device 118. The image displayed on the display device can provides the labels for at

5 least some of the buttons on the keyboard, thus providing dynamic functioning for those buttons, all in a known manner.

The communications device illustrated in Fig. 1 operates as both a telephone caller ID and answering machine, and an e-mail terminal. The subscriber line is used to couple the  
10 device 10 to the public telephone system. The public telephone system is used in the normal way in a telephone mode of operation, and connects the device 10 to an e-mail server or mailbox in an e-mail mode of operation.

In the telephone mode, an incoming telephone call from the  
15 subscriber line causes the device 10 to ring, either via a separate ringer (not shown) or using the speaker-phone speaker 112. At this time, caller ID information, including the telephone number of the originating telephone and the name associated with the originating telephone, is extracted from  
20 the incoming telephone call by the processor 110 via the codec 106 and DSP 108, and displayed in the display device 118, all in a known manner. The caller ID information is further inserted into a database of correspondent information 130, maintained in a portion 130 of the RAM 126 in a manner to be  
25 described in more detail below.

If the user does not answer the call after some predetermined number of rings (e.g. 4), the processor 110 retrieves from the ROM 124 or RAM 126 a digitized version of a message for the originator of the incoming telephone call, for example  
30 asking the originator to leave a message. The combination of the codec 106 and DSP 108 converts the digitized message into an audio message and supplies it to the originating telephone

10

5 via the multiplexer 104. The originator, in turn, can choose to dictate a message for the user. That message is received by the device 10, and digitized via the combination of the codec 106 and DSP 108. The processor then stores the digitized message in a portion 128 of the RAM 126 allocated to storing  
10 such messages. The caller ID information associated with this message is also stored with the message. Other information about the incoming message, such as the date and time it was received, is also stored with the message in the message portion 128 of the RAM 126.

15 In the e-mail mode, the processor 110 accesses the e-mail server by dialing the telephone number of that server, in a known manner. E-mail messages for the user are retrieved, and stored in the RAM 126, also in the message portion 128. Each e-mail message includes identification information, including  
20 the e-mail address and e-mail name of the originator of the message. Other e-mail information relating to that message may also be included, such as the date and time the message was sent, the location from which it was sent, routing information, etc. The e-mail identification information is also stored with  
25 the message in the message portion 128 of the RAM 126. The e-mail information is also inserted into the database of correspondent information 130, maintained in a portion 130 of the RAM 126 in a manner to be described in more detail below.

When a message is received, the identification information  
30 relating to that message (e.g. originating telephone number and name for telephone messages and originating e-mail address and e-mail name for e-mail messages, and possibly other related

11

5 information) is stored in a common database, as referred to above. In this manner the content of the database is maintained.

Fig. 2 is a table describing the structure and contents of a database used to contain correspondent information in the  
10 communications device illustrated in Fig. 1. The structure of the correspondent database is represented in Fig. 2 as a table. Each row of the table represents an entry in the correspondent database and represents one correspondent. Each entry contains a plurality of fields able to hold information relating to the  
15 correspondent represented by that entry. The fields are partitioned into: a group of fields able to contain caller ID information including the telephone number, caller ID name, and other attributes (represented by an ellipsis) related to the telephone for that correspondent; a group of fields able to  
20 contain e-mail identification information including the e-mail address, e-mail name, and other attributes (represented by an ellipsis) related to e-mail of that correspondent; and a group of fields able to contain extensions to the correspondent information, including, for example, the facsimile telephone  
25 number, postal address and other such information (represented by an ellipsis).

When a telephone call is received, the caller ID telephone number and name is extracted from the originating message in a known manner, as described above. The originating telephone  
30 number is compared to the telephone numbers stored in the caller ID number field of all the entries in the database. If a match is found, then the caller ID name field of that entry



12

5 is updated with the originating caller ID name, in case the name for that telephone number has changed. If this happens, one of the caller ID attributes, a status attribute, is changed to "new". For example, if the caller ID information for the originating telephone call is the number 555-4321 and the  
10 name is "John Ray", then this search finds entry 1. The database field containing the caller ID name is replaced with the name "John Ray".

If no entry is found which contains the originating message telephone number in the caller ID number field, then  
15 the originating caller ID name is compared with the names in the e-mail name field of all the entries in the database. In one embodiment, an exact match of the originating name is searched for. In another embodiment, recognizing that the e-mail and telephone caller ID names may not be exactly the same,  
20 a closest match is searched for. Such a search may be made by parsing both the originating message name and extracting last names and first name or first initial, then comparing them. Or a search may be made on like sounding names using the known Soundex system. If no match is found, then a new entry is  
25 created, and the caller ID number and name fields of that entry are filled with the caller ID number and name, respectively, of the originating telephone call. For example, if a telephone call is received with a number 555-6789 and a name of "Dave May", there is neither a match for the caller ID number nor the  
30 e-mail name for such a person. A new entry is created (for example, entry 7) and the caller ID number, 555-6789, is inserted into the caller ID number field of entry 7, and the

13

5 caller ID name, Dave May, is inserted into the caller ID name field of entry 7.

If no entry is found which contains the originating message caller ID number in the caller ID number field, but an entry is found which contains date corresponding to the  
10 originating message caller ID name in the e-mail name field, then the caller ID number and name fields for that entry are checked. If there are entries in those fields, then this entry represents a different correspondent, but with a similar e-mail name. In this case, as well, a new entry is created, and the  
15 caller ID number and name from the originating telephone call are inserted, as described above. For example, if a telephone call is received with a number 555-6789 and a name of "Bill Bey Jr.", The search of the database finds entry 2, but this represents a different correspondent. A new entry is created  
20 (for example, entry 7) and the caller ID number, 555-6789, is inserted into the caller ID number field of entry 7, and the caller ID name, Bill Bey Jr., is inserted into the caller ID name field of entry 7.

If, however, the caller ID number and name fields of that  
25 entry are empty, then it is assumed that this entry represents the same correspondent as that of the originating telephone message. In one embodiment, the caller ID number and name of the originating telephone message are inserted into the caller ID number and name fields, respectively, of the entry.

30 However, this assumption may not be correct. In one preferred embodiment, data from this entry is displayed on the display device 118, and the user allowed to indicate whether this entry

14

5 represents the same correspondent via the keyboard 116. If not, then a new entry is made, as described above. In another preferred embodiment, a list of entries which have e-mail names close to the originating message caller ID name is displayed on the display device 118, and the user selects one of the listed 10 entries, or none at all, using the keyboard. If an entry is selected, it is updated with the caller ID information, otherwise, a new entry is created.

For example, if a telephone call is received with a number 555-9786 and a name Charlie Trei, there is no match for the 15 originating message caller ID number in any caller ID number field of any entry in the database. However, there is a match for the originating message caller ID name in the e-mail name field of entry 6. In this case the caller ID number and name fields are empty. The data related to this entry (and possible 20 other similar entries) is displayed on the display device 118. If the user accepts this entry as representing the caller, then the caller ID number, 555-9786, is inserted into the caller ID number field of entry 6, and the caller ID name, Charlie Trei, is inserted into the caller ID name field of entry 6. If the 25 user does not accept this entry as representing the caller, then a new entry (for example, entry 7) is created, as described above.

In a similar manner, when the communications device 10 receives an e-mail message, it parses the e-mail address and e-mail 30 name from the message. The originating e-mail address is compared to the e-mail address fields of all the entries in the database. If an entry with a matching e-mail address is found,

15

5 the e-mail name is updated to the e-mail name in the originating message. If no entry with a matching e-mail address is found in the database, the originating e-mail name is compared to the caller ID name fields in all the entries in the database. If a matching entry is found and the e-mail address  
10 and e-mail name fields of that entry are empty, the user is allowed to indicate whether the originating e-mail message comes from the same person as represented by that entry, as described above in more detail. If so, the e-mail address and e-mail name is inserted into the e-mail address and e-mail name  
15 fields, respectively, of the entry. Otherwise, a new entry is created with the e-mail address and e-mail name of the originating message, as described above.

As can be seen, Fig. 3, in general when a message is received (301) in either communications medium, the message  
20 address (i.e. caller ID number for telephone messages, and e-mail address for e-mail messages) is extracted from the message (302). The message address field is compared to the address field for the communications medium of the message (i.e., for telephone messages, the caller ID number is compared to the  
25 caller ID number field, and for e-mail messages, the e-mail address is compared to the e-mail address field) for all the entries in the database (304). If a matching entry is found (306), then the name field for the message communications medium is updated with the message name (i.e. caller ID name  
30 for telephone messages, e-mail name for e-mail messages). The database updating is then complete (310).

If a match is not found (306), the message name field is

16

5 compared to the name field in the other communications medium  
(i.e. e-mail name for telephone messages, and caller ID name  
for e-mail messages) for all the entries in the database (312).  
If a matching entry is found (314), then the address and name  
fields for the message medium (i.e. caller ID number and name  
10 for telephone messages, and e-mail address and name for e-mail  
messages) are checked to determine if they are empty (320). If  
not, then a new entry is created with the message address and  
message name in the message medium address and name fields in  
the new entry (316). The database updating is then complete  
15 318. If the message medium address and name fields are empty,  
then the message address and name are inserted into the message  
medium address and name fields, respectively (322), possibly  
with the approval of the user, and possibly with the user  
selecting one of a number of possible matching entries, all as  
20 described above. The database updating is then complete (318).

Referring again to Fig. 1, and the general operation of  
the communication device 10, the display screen 118 displays  
general information, such as the current date and time, the  
number of messages received, etc. The display screen also  
25 displays an integrated list of all messages which have been  
received, both telephone messages and e-mail messages, in a  
list window. Each entry in the list of messages shows the  
originator name -- e.g. caller ID name for telephone messages  
and e-mail name for e-mail messages. Using the keyboard 116,  
30 the user is able to highlight entries in the message list. A  
detail window provides further information about the  
highlighted entry, such as whether it is a telephone or e-mail

17

5 message, the caller ID name and number for telephone messages  
or e-mail address and e-mail name for e-mail messages, the date  
and time associated with the message, etc.

Using the keyboard 116, the user may perform several  
functions for each message. For example, the message may be  
10 retrieved. For telephone messages, the digitized voice message  
is retrieved from the message portion 128 of the RAM 126,  
converted to audio and played back through the speaker 112 by  
the codec 106 and DSP 108 under the control of the processor  
110. For e-mail messages the textual body of the message is  
15 retrieved from the message portion 128 of the RAM 126, and  
displayed on the display device 118. For another example, the  
user may desire to reply to the message.

The user may reply to any message in either communications  
medium. That is, the reply to any message may be by either a  
20 telephone message or an e-mail message. When the user  
indicates, via the keyboard 116, that he wishes to reply to the  
message, a question is displayed on the display device 118  
asking which communications medium is desired for the reply.  
The user supplies the answer to the question via the keyboard  
25 116.

The user may specify that the reply be sent in the same  
communications medium as that of the received message, in which  
case, the destination address of the reply is the address in  
the originating message. I.e., for a telephone medium message  
30 the destination address is the caller ID number of the  
telephone message, and for an e-mail medium message the  
destination address is the originating e-mail address in the e-

18

5 mail message. More specifically, to reply to a telephone  
message by placing a telephone call, the communications device  
10 dials the telephone which sent the message using the stored  
caller ID telephone number. To reply to an e-mail message, a  
reply e-mail envelope is prepared using the e-mail address in  
10 the received e-mail.

However, the user may also specify that the reply be sent  
in the other communications medium. If a user wishes, for  
example, to reply to a telephone message by sending an e-mail  
message, the entry in the database containing the originating  
15 caller ID telephone number of the telephone message in the  
caller ID number field is found. Then the e-mail address field  
of that entry is checked. If there is an e-mail address in  
that field of that entry, an e-mail message header is  
automatically composed using that e-mail address, and an e-mail  
20 composition screen is displayed on the display screen 118. The  
user can then type in the body of the e-mail message using the  
keyboard 116, and send the e-mail message when done.

For example, referring to Fig. 2, if the user wishes to  
reply by an e-mail to a telephone message from caller ID number  
25 555-1234, the entry containing that telephone number in the  
caller ID number field is found (entry 2). The e-mail address  
field of entry 2 is then checked. In entry 2, the e-mail  
address field is not empty but contains an e-mail address  
(Bbey@iil.com). In response, an e-mail header containing the  
30 destination address of Bbey@iil.com is automatically prepared,  
the user types the message, then sends the e-mail message.

If there is no e-mail address in the e-mail address field

19

5 of that entry, then the originating caller ID name is compared  
to the names in the e-mail name fields in all the entries in  
the database. As described above, an exact match may be  
searched for, a match of last and first names, or a match of  
like sounding names. The user may also be allowed to accept or  
10 reject the matching entry, or select one from a number of  
closely matching entries or none at all. If a matching entry  
is accepted, or one is selected by the user, then the e-mail  
address and name from the matching entry is merged with the  
caller ID number and name in the originating message entry to  
15 form a single entry. An e-mail message header is then  
automatically composed, and a message composed and sent by the  
user, as described above.

For example, if the user wishes to reply by an e-mail to a  
telephone message from caller ID number 555-4321, the entry  
20 containing that number is found (entry 1). The e-mail address  
field for entry 1 is empty. Thus, the caller ID name (John  
Ray) is compared to the names in the e-mail name field of the  
other entries. In this case an entry with a corresponding  
name, John Ray, is found (entry 3). The data in entry 3 is  
25 merged with the data in entry 1 to form a single entry with the  
combined information. That is, a single entry is formed having  
a caller ID number field containing 555-4321, a caller ID name  
field containing John Ray, an e-mail address field containing  
JRay@ab.com and an e-mail name field containing John Ray. This  
30 entry could be either entry 1 (deleting entry 3), entry 3  
(deleting entry 1) or a new entry, e.g. entry 7 (deleting both  
entries 1 and 3). An e-mail header containing the destination



20

5 address of JRay@ab.com is then automatically prepared, the user types the message, then sends the e-mail message.

If no matching entry is found, or none is selected by the user, then a message is displayed on the display screen 118 asking the user for the destination e-mail address for the  
10 reply to the telephone message. The user enters the destination e-mail address using the keyboard 116. The destination e-mail address entered by the user is inserted into the e-mail address field of the entry containing the caller ID information for the originating message, and the caller ID name  
15 is inserted into the e-mail name field of that entry. An e-mail message header is then automatically composed, and a message entered and sent by the user, as described above.

For example, if the user wishes to reply by an e-mail to a telephone message from caller ID number 555-1324, the entry  
20 containing that number is found (entry 5). The e-mail address for entry 5 is empty, and there is no other entry having data in the e-mail name field which the user finds matches the caller ID name Hank Day. In this case, an e-mail address for Hank Day is requested from the user, which the user supplies  
25 via the keyboard 116. The e-mail address, for example Hday@cba.com, is inserted into the e-mail address field of entry 5, and the caller ID name, Hank Day, is inserted into the e-mail name field of entry 5. An e-mail header containing the destination address of HDay@cba.com is then automatically  
30 prepared, the user types the message, then sends the e-mail message.

Similarly, if a user wishes to reply to a e-mail message

21

5 by placing a telephone call, the entry in the database  
containing the originating e-mail address of the e-mail message  
is found. The caller ID number field of that entry is then  
checked. If there is a telephone number in that field of that  
entry then the telephone number is automatically dialed by the  
10 processor 110 via the DSP/08 and coder 106. If, however, there is  
no telephone number in the caller  
ID number field in that entry, then the originating e-mail name  
is compared to the caller ID name fields in all the entries in  
the database. As described above, this search may be for an  
15 exact match, a match of last and first names, or a match of  
like sounding names. In addition, the user may be given the  
opportunity to accept or reject the matching entry, or select  
one from a number of closer matching entries, or none at all.  
If a matching entry is found, or one is selected by the user,  
20 then the telephone number in the caller ID number field of the  
matching entry is automatically dialed by the processor 110 via  
the DSP 108 and codec 106. In addition, the caller ID number  
and name from the matching entry is merged with the e-mail  
number and name in the originating message entry to form a  
25 single entry. If no matching entry is found, or none is  
selected by the user, then the user may insert caller ID  
information by entering a destination telephone number. The  
destination telephone number entered by the user is inserted  
into the caller ID number field of the entry containing the  
30 originating e-mail message information, and the e-mail name is  
inserted into the caller ID name field of that entry. The  
user-entered telephone number is then automatically dialed, as

5 described above.

As can be seen in Fig. 4, in general when a message is received in one medium and is to be replied to in the other communications medium (401), the entry in the database section 130 of the RAM 126 containing the originating address of the  
10 message in the fields relating to the communications medium of the received message is found (402). The address field relating to the other communications medium is checked (404). If that field is not empty (406), then a message in the other communications medium is composed and sent using the address in  
15 the address field relating to the other communications medium (408). The reply process then ends (410). If that field is empty (406), then the name contained in the originating message is compared to the name field related to the other communications medium in all the entries in the database (412).

20 If an entry is found (414), then a single entry in the database is formed by merging the information contained in the entry relating to the communications medium of the original message with the information contained in the matching entry relating to the other communications medium (416). Then a  
25 message in the other communications medium is composed and sent using the address in the address field relating to the other communications medium of the found entry (418).

If such an entry is not found, then a new record is created (422). The user is prompted for the destination  
30 address for the message in the other communications medium. The destination address is inserted into the address field for the other communications medium, and the name field for the

23

5 message communications medium is inserted into the name field  
for the other communications medium (422). Then a message in  
the other communications medium is composed and sent using the  
address in the address field relating to the other  
communications medium of the found entry (424). The reply  
10 process then ends (426).

A communications device operating according to the present  
invention permits automatic replies in any communications  
medium to any received message.

## CLAIMS:

1. Method for communicating messages, comprising the steps of:
  - receiving a first message via a first communications medium;
  - extracting from the first message first address information associated with the first communications medium;
  - determining in response to the first address information second address information associated with a second communications medium by searching a database comprising a plurality of entries, each of the entries having a respective address field and a name field associated with, respectively, the first communications medium, and also with the second communications medium, the database being searched first in a first entry of said entries and if not present searched in a second entry of said entries to locate an address in the address field for the first message in the first communications medium to provide second address information and if not found requesting an address from a user and saving the user-supplied address in one of the entries to provide said second address information.
2. The method of claim 1 further comprising the step of sending a reply for the first message via the second communications medium using the second address information.
3. The method of claim 1 further comprising the step of:
  - searching for an entry in the database with a name in said second communications medium matching a name determined from said first message, if no entry is found having the same first address information.
4. A method for automatically providing a destination address for a reply in a first communications medium to a message received from an originating address and originating name in a second communications medium, comprising

the steps of:

searching a correspondent data base containing a plurality of entries, each entry representing a correspondent and containing an address field and a name field for messages in the first communications medium and an address field and a name field for messages in the second communications medium, for a first entry containing the originating address in the address field for messages in the second communications medium;

if the first entry contains an address in the address field for messages in the first communications medium, providing that address as the destination address;

if the first entry does not contain an address in the address field for messages in the first communications medium, searching the correspondent data base for a second entry having a name in the name field for messages in the first communications medium corresponding to the originating name;

if a second entry is found, providing an address from the address field for messages in the first communications medium in the second entry as the destination address and merging the first and second entries;

if a second entry is not found, requesting an address from a user, saving the user-supplied address in the address field for messages in the first communications medium in the first entry, saving the originating name in the name field for messages in the first communications medium in the first entry, and providing the user-supplied address as the destination address.

5. The method of claim 4 further comprising the step of maintaining the entries in the correspondent database in response to the received message in one of the first and second communications media.

6. The method of claim 5 wherein the maintaining step comprises the steps of:

extracting the originating address of the message from the message;

searching the correspondent database for a third entry containing the originating address in the address field for messages in the one of the first and second communications media;

if a third entry is found, then inserting the originating name into the name field for messages in the one of the first and second communications media;

if a third entry is not found, then searching the correspondent database for a fourth entry containing a name in the name field for messages in the other one of the first and second communications media corresponding to the originating name;

if a fourth entry is found, then if the address field for messages in the other one of the first and second communications media and the name field for messages in the other one of the first and second communications media in the fourth entry are blank, then inserting the originating address into the address field for messages in the other one of the first and second communications media in the fourth entry and inserting the originating name into the name field for messages in the other one of the first and second communications media in the fourth entry;

otherwise, adding a new entry to the correspondent database and inserting the originating address into the address field for messages in the one of the first and second communications media in the new entry and inserting the originating name in the name field for messages in the one of the first and second communications media in the new entry.

7. The method of claim 6 wherein the step of searching the correspondent data base for a fourth entry comprises the step of:

searching for a plurality of close matches between the originating name and the name in the name field for messages in the other one of the first and second communications media;

displaying the list of entries; and  
allowing the user to select one of the list of entries as the fourth entry.

8. The method of claim 6 wherein the step of searching the correspondent data base for a fourth entry comprises the step of searching for an exact match between the originating name and the name in the name field for messages in the other one of the first and second communications media.

9. The method of claim 6 wherein the step of searching the correspondent data base for a fourth entry comprises the step of searching for a closest match between the originating name and the name in the name field for messages in the other one of the first and second communications media.

10. The method of claim 4 wherein the step of searching the correspondent data base for a second entry comprises the step of:

searching for a plurality of close matches between the originating name and the name in the name field for messages in the first communications medium;

displaying the list of entries; and

allowing the user to select one of the list of entries as the second entry.

11. The method of claim 4 wherein the step of searching the correspondent data base for a second entry comprises the step of searching for an exact match between the originating name and the name in the name field for messages in the first communications medium.

12. The method of claim 4 wherein the step of searching the correspondent data base for a second entry comprises the step of searching for a closest match between the originating name and the name in the name field for messages in the first communications medium.



13. The method of claim 4 wherein:

one of the first and second communications media is e-mail, the address for e-mail messages is the e-mail address, and the name for e-mail messages is the name of the e-mail correspondent; and

the other one of the first and second communications media is telephone, the address for telephone messages is the caller ID telephone number and the name for telephone messages is the caller ID name of the telephone correspondent.

14. Apparatus for automatically providing a destination address for a reply in a first communications medium to a message received from an originating address and originating name in a second communications medium, comprising:

a database memory storing a correspondent data base containing a plurality of entries, each entry representing a correspondent and containing an address field and a name field for messages in the first communications medium and an address field and a name field for messages in the second communications medium;

a user input device;

a display device; and

a processor, coupled to the database memory, the user input device and the display device, and responsive to instructions stored in a control program memory for:

conditioning the database memory to retrieve entries searching for a first entry containing the originating address in the address field for messages in the second communications medium;

if the first entry contains an address in the address field for messages in the first communications medium, then providing that address as the destination address;

if the first entry does not contain an address in the address field for

messages in the first communications medium, then conditioning the database memory to retrieve entries searching for a second entry having a name in the name field for messages in the first communications medium corresponding to the originating name;

if a second entry is found, providing an address from the address field for messages in the first communications medium in the second entry as the destination address, merging the first and second entries, and conditioning the database memory store the merged entry in the database memory; and

if a second entry is not found, conditioning the display device to display a request for a destination address, conditioning the user input device to receive a destination address from the user, conditioning the database memory to store the user-supplied destination address in the address field for messages in the first communications medium in the first entry and to store the originating name in the name field for messages in the first communications medium in the first entry, and providing the user-supplied address as the destination address.

15. The apparatus of claim 14, further comprising:

an input terminal, coupled to the processor, and able to receive messages in the first and second communications media; and

a message memory, coupled to the processor; and wherein:

the processor is further responsive to the instructions for:

conditioning the message memory to store messages received from the input terminal in the message memory; and

conditioning the database memory to maintain the entries in the database memory in response to the received message.

16. The apparatus of claim 15 wherein the processor is further responsive to the instructions for:

conditioning the message memory to extract the originating address of

the received message;

conditioning the database memory to retrieve entries searching for a third entry containing the originating address in the address field for messages in the one of the first and second communications media;

if a third entry is found, then conditioning the database memory to insert the originating name into the name field for messages in the one of the first and second communications media of the third entry;

if a third entry is not found, then conditioning the database memory to retrieve entries searching the database memory for a fourth entry containing a name in the name field for messages in the other one of the first and second communications media corresponding to the originating name;

if a fourth entry is found, and if the address field for messages in the other one of the first and second communications media and the name field for messages in the other one of the first and second communications media in the fourth entry are blank, then conditioning the database memory to insert the originating address into the address field for messages in the other one of the first and second communications media in the fourth entry and to insert the originating name into the name field for messages in the other one of the first and second communications media in the fourth entry;

otherwise, conditioning the database memory to add a new entry, to insert the originating address into the address field for messages in the one of the first and second communications media in the new entry and to insert the originating name in the name field for messages in the one of the first and second communications media in the new entry.

17. The apparatus of claim 16 wherein the processor is further responsive to the instructions for conditioning the database memory to retrieve entries searching for a fourth entry by:

searching for a plurality of close matches between the originating name and the name in the name field for messages in the other one of the first and

second communications media;

conditioning the display device to display the list of entries; and

conditioning the user input device to receive user input allowing the user to select one of the list of entries as the fourth entry.

18. The apparatus of claim 14 wherein the processor is further responsive to the instructions for conditioning the database memory to retrieve entries searching for a second entry by:

searching for a plurality of close matches between the originating name and the name in the name field for messages in the first communications medium;

conditioning the display device to display the list of entries; and

conditioning the user input device to allow the user to select one of the list of entries as the second entry.

19. The apparatus of claim 14 wherein the processor is further responsive to the instructions for conditioning the database memory to retrieve entries searching for a second entry by searching for an exact match between the originating name and the name in the name field for messages in the first communications medium.

20. The apparatus of claim 14 wherein the processor is further responsive to the instructions for conditioning the database memory to retrieve entries searching for a second entry by searching for a closest match between the originating name and the name in the name field for messages in the first communications medium.

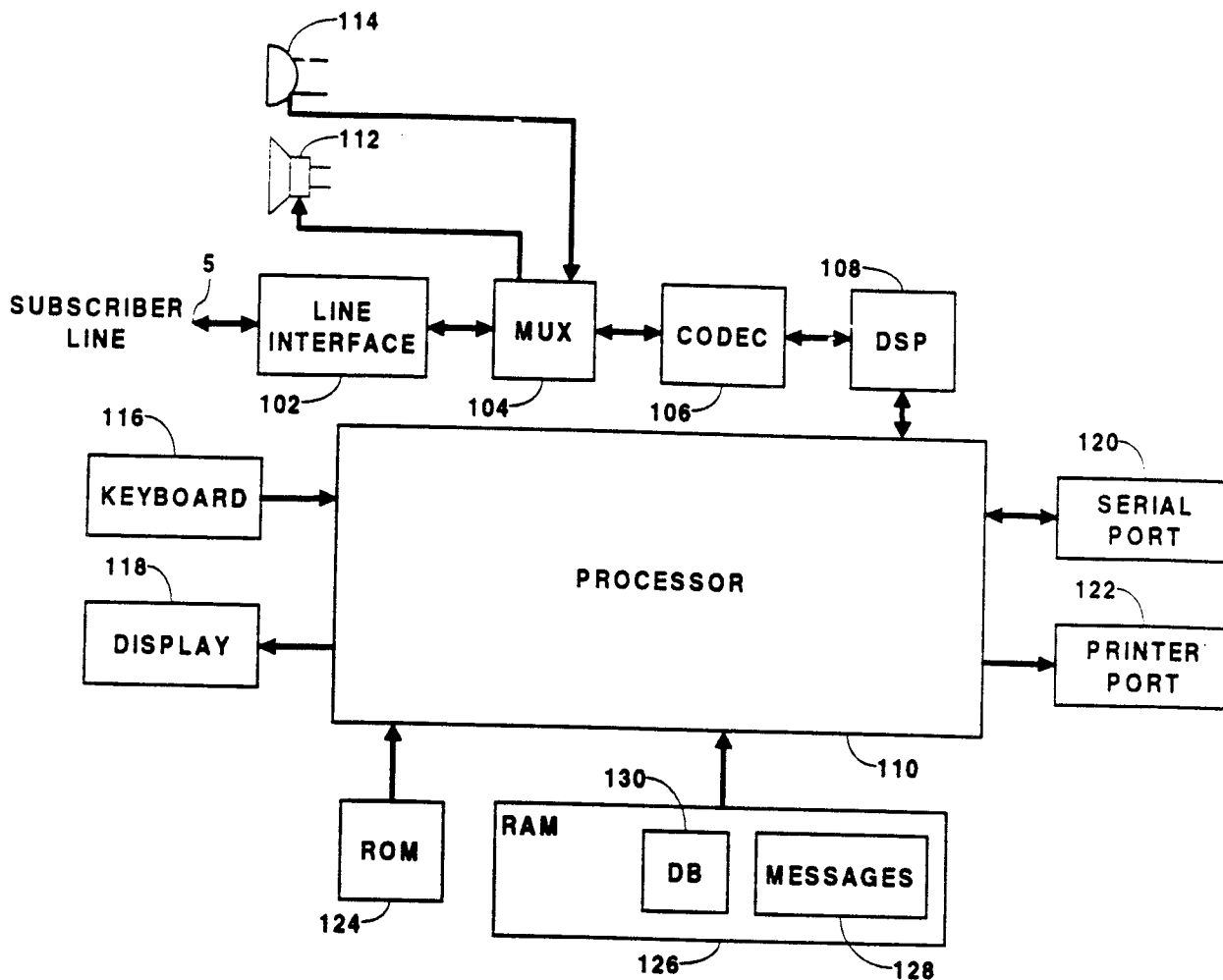

Fig. 1

ENTRY	CALLER ID			E-MAIL			EXTENSIONS		
	NUMBER	NAME	...	ADDRESS	REAL NAME	...	FAX NUMBER	POSTAL ADDRESS	...
1	555-4321	John Ray							
2	555-1234	Bill Bey		BBey @ ili.com	Bill Bey				
3				JRay @ ab.com	John Ray				
4	555-4231	Tom Hays		THays @ ili.com	Tom Hays				
5	5551324	Hank Day							
6				CTrei @ ili.com	Charlie Trei				

Fig. 2

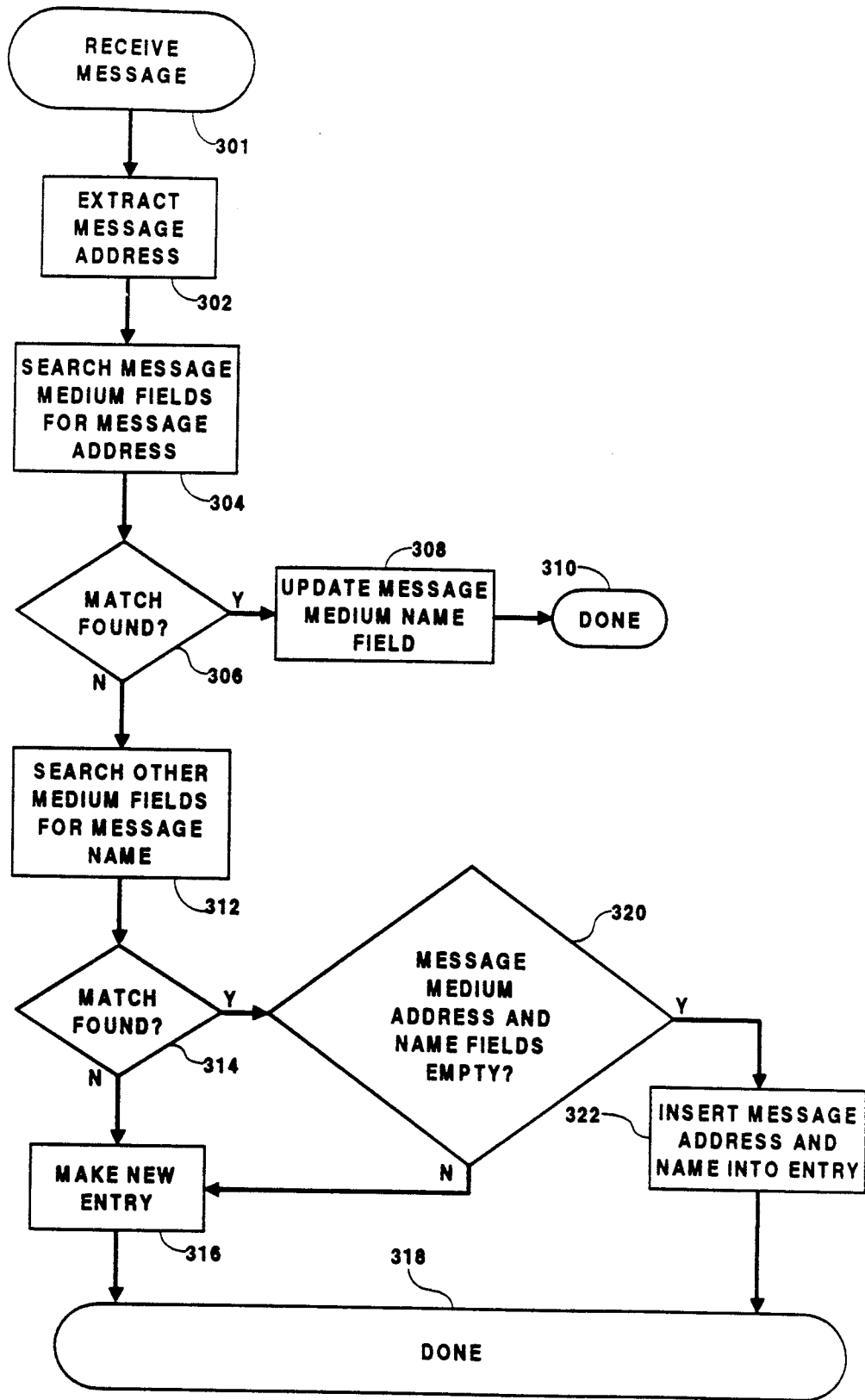

Fig. 3

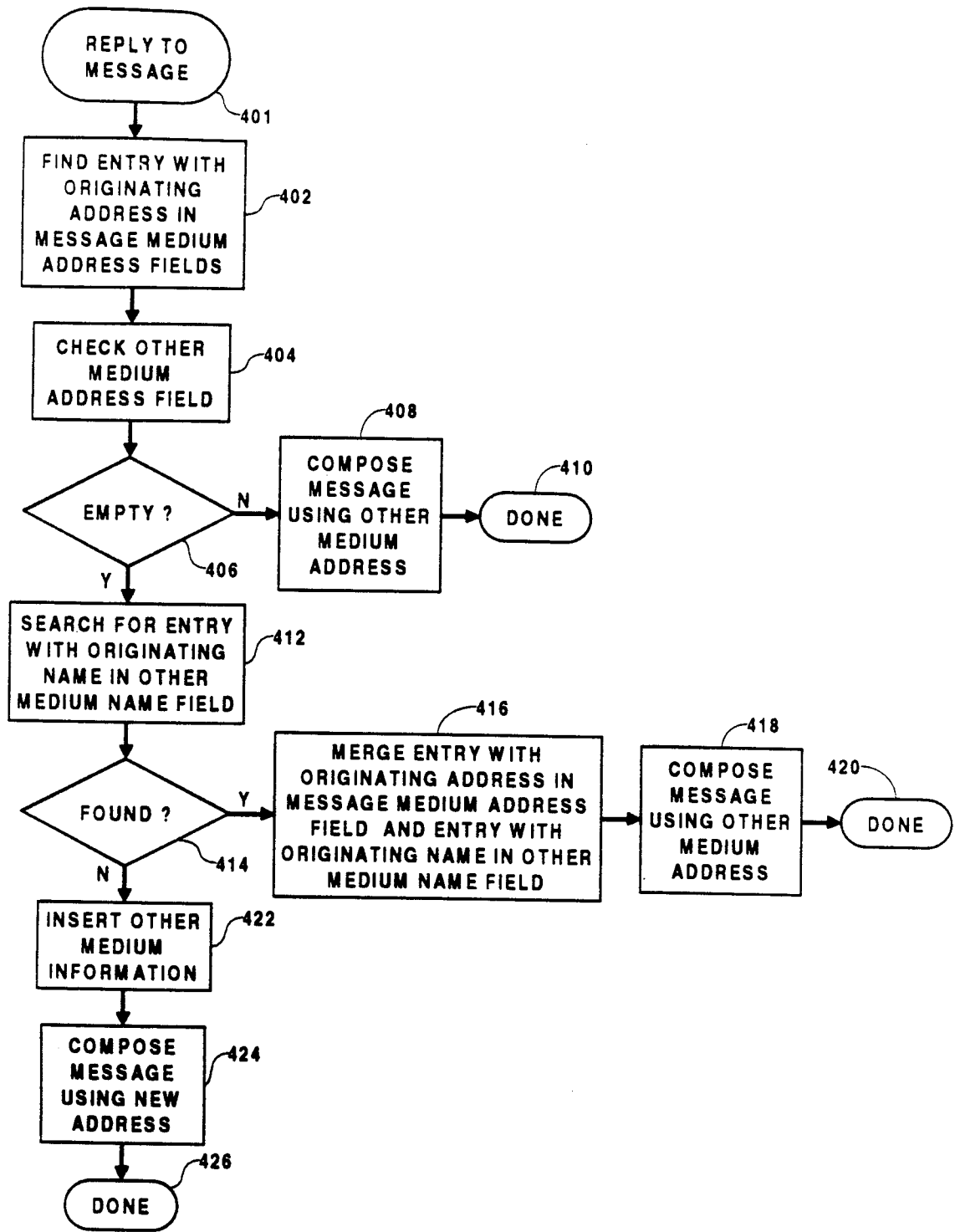

Fig. 4



