

(19) World Intellectual Property Organization
International Bureau



(43) International Publication Date
12 March 2009 (12.03.2009)

PCT

(10) International Publication Number
WO 2009/032377 A1

- (51) International Patent Classification:
H01F 3/10 (2006.01)
 - (21) International Application Number:
PCT/US2008/066305
 - (22) International Filing Date: 9 June 2008 (09.06.2008)
 - (25) Filing Language: English
 - (26) Publication Language: English
 - (30) Priority Data:
60/970,578 7 September 2007 (07.09.2007) US
12/134,240 6 June 2008 (06.06.2008) US
 - (71) Applicant (for all designated States except US): **VISHAY DALE ELECTRONICS, INC.** [US/US]; 1122 23rd Street, Columbus, NE 68601 (US).
 - (72) Inventor; and
 - (75) Inventor/Applicant (for US only): **HANSEN, Thomas, T.** [US/US]; 1122 23rd Street, Columbus, NE 68601 (US).
 - (74) Agent: **GOODHUE, John, D.**; McKee, Voorhees, & Sease, PLC, 801 Grand Ave, Suite 3200, Des Moines, Iowa 50309 (US).
 - (81) Designated States (unless otherwise indicated, for every kind of national protection available): AE, AG, AL, AM, AO, AT, AU, AZ, BA, BB, BG, BH, BR, BW, BY, BZ, CA, CH, CN, CO, CR, CU, CZ, DE, DK, DM, DO, DZ, EC, EE, EG, ES, FI, GB, GD, GE, GH, GM, GT, HN, HR, HU, ID, IL, IN, IS, JP, KE, KG, KM, KN, KP, KR, KZ, LA, LC, LK, LR, LS, LT, LU, LY, MA, MD, ME, MG, MK, MN, MW, MX, MY, MZ, NA, NG, NI, NO, NZ, OM, PG, PH, PL, PT, RO, RS, RU, SC, SD, SE, SG, SK, SL, SM, SV, SY, TJ, TM, TN, TR, TT, TZ, UA, UG, US, UZ, VC, VN, ZA, ZM, ZW.
 - (84) Designated States (unless otherwise indicated, for every kind of regional protection available): ARIPO (BW, GH, GM, KE, LS, MW, MZ, NA, SD, SL, SZ, TZ, UG, ZM, ZW), Eurasian (AM, AZ, BY, KG, KZ, MD, RU, TJ, TM), European (AT, BE, BG, CH, CY, CZ, DE, DK, EE, ES, FI, FR, GB, GR, HR, HU, IE, IS, IT, LT, LU, LV, MC, MT, NL, NO, PL, PT, RO, SE, SI, SK, TR), OAPI (BF, BJ, CF, CG, CI, CM, GA, GN, GQ, GW, ML, MR, NE, SN, TD, TG).
- Published:**
— with international search report

(54) Title: HIGH POWER INDUCTORS USING A MAGNETIC BIAS

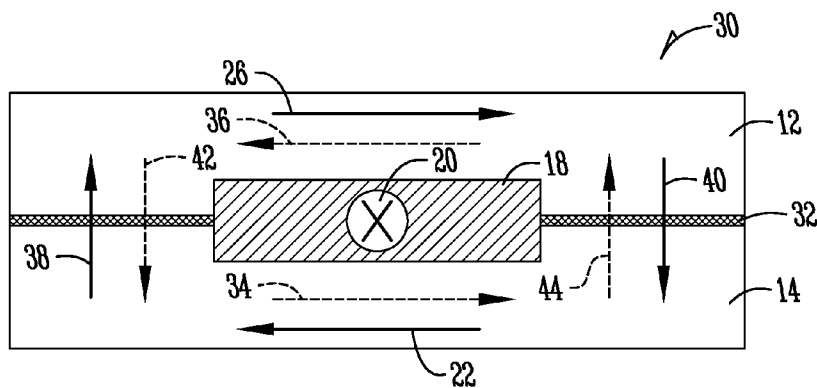

Fig. 2

(57) Abstract: A biased gap inductor includes a first ferromagnetic plate, a second ferromagnetic plate, a conductor sandwiched between the first ferromagnetic plate and the second ferromagnetic plate, and an adhesive between the first ferromagnetic plate and the second ferromagnetic plate, the adhesive comprising magnet powder to thereby form at least one magnetic gap. A method of forming an inductor includes providing a first ferromagnetic plate and a second ferromagnetic plate and a conductor, placing the conductor between the first ferromagnetic plate and the second ferromagnetic plate, adhering the first ferromagnetic plate to the second ferromagnetic plate with a composition comprising an adhesive and a magnet powder to form magnetic gaps, and magnetizing the inductor.



WO 2009/032377 A1

HIGH POWER INDUCTORS USING A MAGNETIC BASIS

5 **CROSS-REFERENCE TO RELATED APPLICATIONS**

This application claims priority under 35 U.S.C. § 119 to provisional application Serial No. 60/970,578 filed September 7, 2007, herein incorporated by reference in its entirety.

10 **BACKGROUND OF THE INVENTION**

Low profile inductors, commonly defined as inductors having a profile less than about 10 mm are in existence today in the form of ferrites with unique geometries and pressed iron powder around a wound coil. Ferrite based low profile inductors have an inherent limitation of magnetic saturation at relatively low levels of current. When
15 magnetic saturation occurs, inductance value decreases dramatically.

Pressed iron inductors allow for much higher input current than ferrite inductors, but have the limitation of producing high core losses at high frequencies (such as frequencies greater than 200 kHz). What is needed is an efficient means to provide inductance at high frequencies allowing high input currents.

20 It is therefore a primary, object, feature, or advantage of the present invention to improve upon the state of the art.

It is a further object, feature, or advantage of the present invention to provide an inductor which has lower core losses at high ripple currents (> 5 A) and frequencies (> 200 kHz) in a thin package yet also have the high saturation current performance of powdered
25 iron.

Another object, feature, or advantage of the present invention is to use adhesive film thickness or magnet particle size to adjust inductance characteristics.

A further object, feature, or advantage of the present invention is to increase the capability of an inductor to effectively handle more DC while maintaining inductance.

30 One or more of these and/or other objects, features, or advantages of the present invention will become apparent from the description of the invention that follows.

BRIEF SUMMARY OF THE INVENTION

According to one aspect of the present invention, a biased gap inductor includes a first ferromagnetic plate, a second ferromagnetic plate, a conductor sandwiched between the first ferromagnetic plate and the second ferromagnetic plate, and an adhesive between
5 the first ferromagnetic plate and the second ferromagnetic plate, the adhesive comprising magnetically hard magnet powder to thereby form at least one magnetic gap. The adhesive has a thickness of less than 500 μm and preferably less than 100 μm . The magnetic powder size can be used to set the inductance level of the part. Also the amount of magnet powder can modify characteristics of the part to produce a desired performance.

10 According to another aspect of the present invention, a method of forming an inductor includes providing a first ferromagnetic plate and a second ferromagnetic plate and a conductor, placing the conductor between the first ferromagnetic plate and the second ferromagnetic plate, adhering the first ferromagnetic plate to the second ferromagnetic plate with a composition comprising an adhesive and a magnet powder to form magnetic gaps,
15 and magnetizing the inductor. The composition has a thickness of less than 500 μm and preferably less than 100 μm .

According to another aspect of the present invention, a biased gap inductor is provided. The inductor includes a first ferromagnetic plate and a second ferromagnetic plate. A conductor is sandwiched between the first ferromagnetic plate and the second
20 ferromagnetic plate. A magnetic material having a thickness of less than 100 μm is between the first ferromagnetic plate and the second ferromagnetic plate to form at least one magnetic gap. The thickness may be used to define inductance characteristics of the inductor.

25 BRIEF DESCRIPTION OF THE DRAWINGS

FIG. 1 is a cross-section of a prior art inductor without flux channeling.

FIG. 2 is a cross-section of one embodiment of a flux-channeled inductor of the present invention.

FIG. 3 illustrates a relationship between DC voltage and a BH-loop and how
30 operation range is increased with the biased gap.

FIG. 4 illustrates a single conductor inductor with two magnetic gaps.

FIG. 5 is a perspective view of a multi-poled configuration of an inductor.

DETAILED DESCRIPTION OF THE PREFERRED EMBODIMENT

FIG. 1 illustrates a prior art device where a single strip of copper can be placed
5 between two ferrite parts to create an inductor. While this is effective in creating low
value, high frequency inductors, it limits the amount of input current the inductor can
handle without saturating. The primary cause of saturation comes from the fact that all
magnetic flux induced by the copper flows through narrow cross-sectional areas. FIG. 1
10 illustrates the flux pattern in a single copper strip inductor. In FIG. 1, an inductor **10** has a
first ferromagnetic plate **12** and a second ferromagnetic plate **14**. There is a spacing **16**
between the first ferromagnetic plate **12** and the second ferromagnetic plate **14**. The
magnetic flux induced by a current through the single strip copper conductor **18** is split
between each plate **12**, **14**. Input current **20** is shown using notation to indicate that the
15 current is flowing into the page. Arrows **22**, **24**, **26**, **28** indicate the direction of magnetic
flux induced by the current **20** through the conductor **18**. Note that all the magnetic flux
induced by the current in the copper conductor **18** flows through narrow cross-sectional **22**,
26 areas thereby becoming the primary cause of saturation.

The present invention provides a low cost method which enables inductors to
extend their operating range up to a factor of two. The invention introduces adhesive filled
20 with magnet powder in the gaps between ferromagnetic pieces. FIG. 2 illustrates one
embodiment of the present invention. An inductor **30** is shown which is formed from a
first ferromagnetic plate **12** and a second ferromagnetic plate **14**. The first ferromagnetic
plate **12** and the second ferromagnetic plate **14** are mechanically bonded through a
composition **32** which includes an adhesive and a magnet powder. Arrows **22**, **26**, **38**, **40**
25 indicate the direction of magnetic flux induced by the current **20** through the conductor **18**.
Arrows **34**, **36**, **42**, **44** indicate the direction of magnet induced "counter" flux.

The composition **32** may be comprised of epoxy and magnet powder mixed in
predetermined ratios. The use of the adhesive with the magnet powder has a dual role in
the assembly of an inductive component. Varying the size of the magnet particulate raises
30 or lowers the inductance of the part. Small magnet powder size creates a thin gap inductor
with a high inductance level. A large magnet powder increases the gap size resulting in a

reduced inductance of a part. Thus, the magnet powder particulate size can be selected to tailor the inductance of a part for a specific application. In other words, the magnet powder size can be used to set the inductance level of the part. Also, the amount of magnet powder used can modify characteristics of the part to produce a desired performance. The second
5 role of the adhesive is to permanently bind the parts together making the assembly robust to mechanical loads. In a preferred embodiment, the thickness of the magnet particulate layer is between about 0 to 100 μm . Larger magnetic bias thickness of between about 0 and 500 μm may also be used.

The magnet powder can consist of a spherical or irregular shaped material.
10 Ceramic magnet powders can be used as the magnet powder. The preferred materials are spherical rare earth magnetic material such as, but not limited to, Neodymium-Iron-Boron or Samarium-Cobalt magnet powder. One reason is that spherical particulate is more consistent at achieving specific distances between plates. The second reason is rare earth magnets have sufficiently high intrinsic coercive forces to resist demagnetization in
15 application.

Ferromagnetic plates can be made from a magnetically soft material such as, without limitation, ferrite, molypermalloy (MPP), Sendust, Hi Flux, or pressed iron. Although other materials may be used, a preferred material is ferrite as it has low core losses at high frequencies and is generally less expensive than alternatives. Ferrite has low
20 magnetic saturation resistance and thus benefits from introducing a magnetic bias.

The present invention provides for adding magnet powder filled adhesive between ferromagnetic plates. Once the adhesive is fully cured, the component is magnetized such that the magnetic material applies a steady state magnetic flux field that opposes the direction induced from a current carrying inductor.

25 FIG. 2 illustrates the static magnetic flux and the induced magnetic flux from the conductor. FIG. 3 is a hypothetical B-H loop of soft ferromagnetic ferrite plates. At zero input DC into the conductor, the ferromagnetic material is polarized or biased such that its flux field is near the maximum negative saturation point. When DC is applied, this negative flux field gradually decreases until the magnetic flux density in the ferromagnetic
30 material is zero. Upon further increase in DC, the magnetic flux field begins to go positive until magnetic saturation occurs. Introducing magnetic material in the gap thus increases

the ferromagnetic material's ability to withstand saturation thereby significantly increasing its range, such as by two times.

FIG. 4 is a perspective view of a single conductor inductor **50** with two magnetic gaps. In FIG. 4, two ferromagnetic plates **52**, **53** are combined together by a distance set by the size of the magnetic particulate. A mixture of magnet powder and epoxy forms the composition **56** which may be screen printed onto one of the sides of the ferromagnetic plates, ferromagnetic plate **52** as shown in FIG. 4. A magnetic gap is created in each region where the composition **56** is applied. A second ferromagnetic plate **53** is placed upon the first and the adhesive is heat cured to permanently bond the assembly together. Once the parts are cured, they are then magnetized. FIG. 4 illustrates the polarity of the magnetic material such that the subsequent flux field between the two ferromagnetic plates adds to each others magnetic flux direction. The polarity of the magnet induced flux is set in the opposite direction to any magnetic induced flux caused from direct current input into the conductor.

FIG. 5 is a perspective view of one embodiment where there are three magnetic gaps, each of the magnetic gaps formed for a mixture containing magnet powder and preferably an adhesive such as epoxy. The mixture can be deposited by screen printing and can be considered a magnetic film as it includes a magnet powder is applied in three separate places, **70A**, **70B**, **70C**. The configuration shown in a multi-poled configuration. The outside magnetic films **70A**, **70B** are polarized in the same direction while the center **70C** is polarized in an opposite direction. This is performed in order to form a magnetic field that will be additive for all three magnetic films. The inductor **60** include a first ferromagnetic plate **62** and a second ferromagnetic plate **64**. There are grooves **63** cut in ferromagnetic plate **62**. The grooves **63** extend from one side of the ferromagnetic plate **62** to an opposite side of the ferromagnetic plate **62**. A conductor **65** is shown. The conductor **65**, which includes segments **66**, **68** on the side of the second ferromagnetic plate **64** is bent around the second ferromagnetic plate **64** to form three surfaces **70A**, **70B**, **70C** upon each of which the magnetic film is adhered. After the ferromagnetic plates **62**, **64** are placed together, the adhesive may be heat cured, then device **60** may be magnetized. FIG. 5 provides a multi-poled configuration as the outside magnetic films are polarized in the same direction while the center is polarized in an opposite direction. This is done to form a

magnetic field that will be additive for all three magnetic films. The polarity of the magnet induced flux is set in the opposite direction to any magnetic induced flux caused from direct current input into the conductor.

Thus, it should be apparent that the present invention provides for improved
5 inductors and methods of manufacturing the same. The present invention contemplates numerous variations in the types of materials used, manufacturing techniques applied, and other variations which are within the spirit and scope of the invention.

What is claimed is:

1. A biased gap inductor, comprising:
a first ferromagnetic plate;
5 a second ferromagnetic plate;
a conductor sandwiched between the first ferromagnetic plate and the second ferromagnetic
plate;
an adhesive between the first ferromagnetic plate and the second ferromagnetic plate, the
adhesive comprising magnet powder to thereby form at least one magnetic gap; and
10 wherein the adhesive having a thickness of less than 500 um.
2. The biased gap inductor of claim 1 wherein the adhesive is epoxy.
3. The biased gap inductor of claim 1 wherein the magnet powder comprises spherical
15 rare earth magnetic particulate.
4. The bias gaped inductor of claim 3 wherein the spherical rare earth magnetic
particulate comprises a neodymium-iron-boron alloy.
- 20 5. The bias gaped inductor of claim 3 wherein the spherical rare earth magnetic
particulate comprises a samarium-cobalt alloy.
6. The bias gaped inductor of claim 1 wherein each of the first ferromagnetic plate and
the second ferromagnetic plate comprises ferrite.
25
7. The bias gaped inductor of claim 1 wherein the conductor comprises copper.
8. The bias gaped inductor of claim 1 wherein the conductor is configured in a
multiple loop configuration.
30

9. The bias gaped inductor of claim 1 wherein the adhesive comprises an adhesive film between the first ferromagnetic plate and the second ferromagnetic plate, and the thickness is used to define inductance characteristics of the inductor.
- 5 10. The bias gaped inductor of claim 1 wherein the thickness is less than 100 um.
11. A method of forming an inductor, comprising:
providing a first ferromagnetic plate and a second ferromagnetic plate and a conductor;
placing the conductor between the first ferromagnetic plate and the second ferromagnetic
10 plate;
adhering the first ferromagnetic plate to the second ferromagnetic plate with a composition
comprising an adhesive and a magnet powder to form magnetic gaps;
magnetizing the inductor; and
wherein the composition having a thickness of less than 500 um.
- 15 12. The method of claim 11 wherein the step of adhering includes curing the adhesive.
13. The method of claim 11 wherein the adhesive is epoxy.
- 20 14. The method of claim 11 wherein the magnet powder comprises spherical rare earth magnetic particulate.
15. The method of claim 11 wherein the magnet powder comprises spherical ceramic particulate.
- 25 16. The method of claim 11 further comprising determining a type of magnet powder based on desired properties for the inductor, wherein the type includes the size of particles of the magnet powder.
- 30 17. The method of claim 11 wherein the step of adhering includes screen printing the composition.

18. The method of claim 11 wherein the thickness is less than 100 μm .

19. A biased gap inductor, comprising:

5 a first ferromagnetic plate;

a second ferromagnetic plate;

a conductor sandwiched between the first ferromagnetic plate and the second ferromagnetic plate;

10 a magnetic material having a thickness of less than 100 μm between the first ferromagnetic plate and the second ferromagnetic plate to form at least one magnetic gap, wherein

the thickness being used to define inductance characteristics of the inductor.

1/3

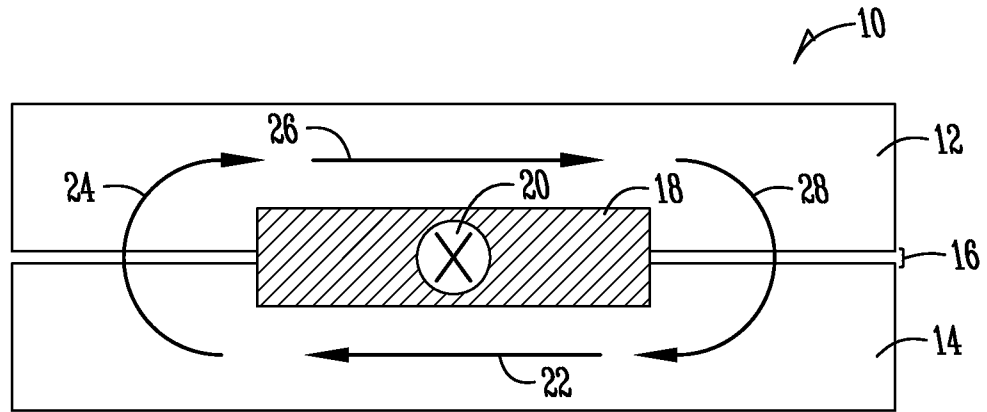

Fig. 1 (PRIOR ART)

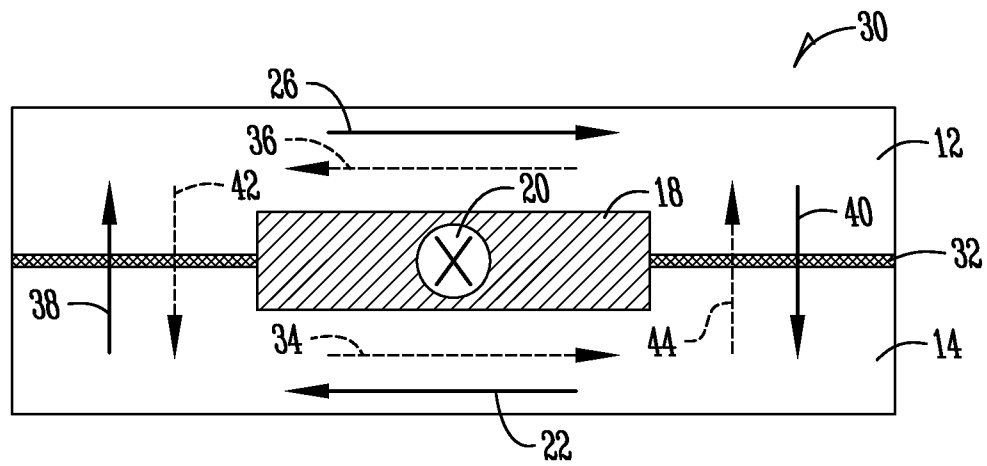

Fig. 2

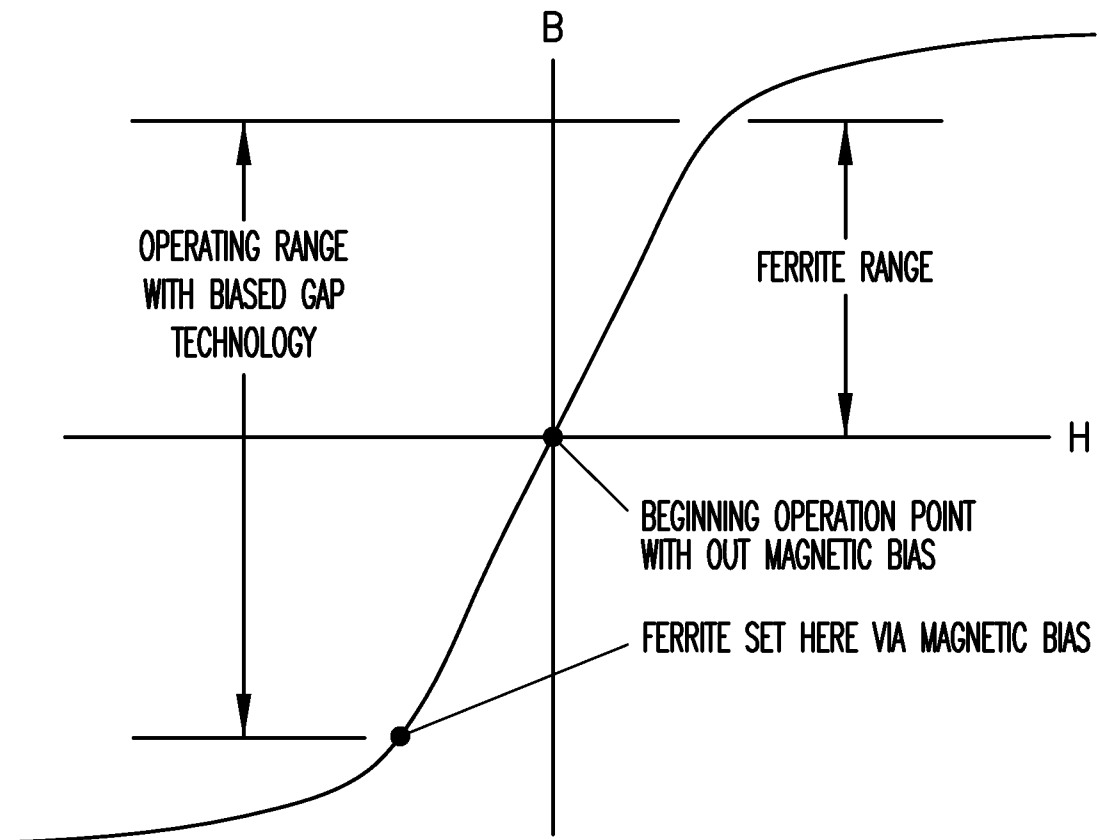

Fig. 3

3/3

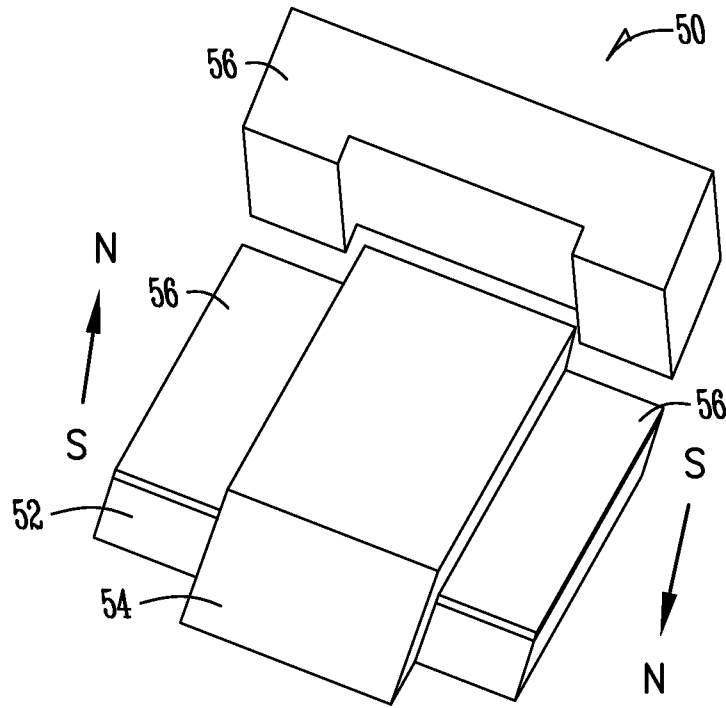

Fig. 4

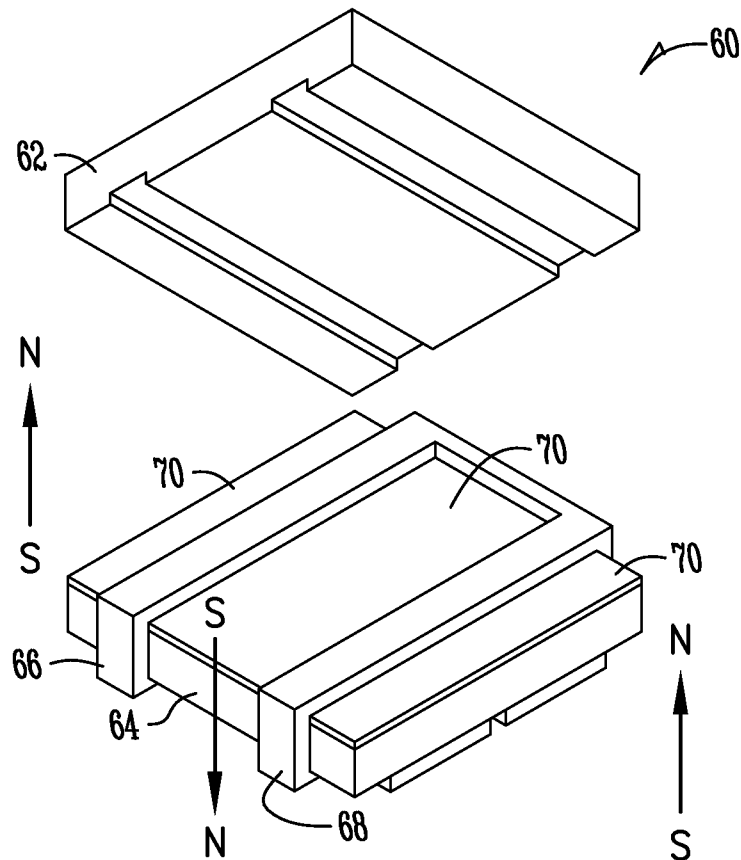

Fig. 5

INTERNATIONAL SEARCH REPORT

International application No

PCT/US2008/066305

A. CLASSIFICATION OF SUBJECT MATTER INV. H01F3/10		
According to International Patent Classification (IPC) or to both national classification and IPC		
B. FIELDS SEARCHED		
Minimum documentation searched (classification system followed by classification symbols) H01F		
Documentation searched other than minimum documentation to the extent that such documents are included in the fields searched		
Electronic data base consulted during the international search (name of data base and, where practical, search terms used) EPO-Internal		
C. DOCUMENTS CONSIDERED TO BE RELEVANT		
Category*	Citation of document, with indication, where appropriate, of the relevant passages	Relevant to claim No.
X	US 2004/207500 A1 (FUJIWARA TERUHIKO [JP] ET AL) 21 October 2004 (2004-10-21) paragraphs [0013], [0018], [0019], [0065], [0066], [0095], [0103], [0123], [0124], [0128]	1-19
A	JP 07 283046 A (NIPPON STEEL CORP) 27 October 1995 (1995-10-27) abstract	1-19
A	US 6 392 525 B1 (KATO JUNICHI [JP] ET AL) 21 May 2002 (2002-05-21) paragraphs [0009], [0052], [0053], [0084]; figure 4	1-19
A	EP 1 286 371 A (OSRAM SYLVANIA INC [US]) 26 February 2003 (2003-02-26) paragraphs [0027] - [0033]	1-19
-/--		
<input checked="" type="checkbox"/> Further documents are listed in the continuation of Box C. <input checked="" type="checkbox"/> See patent family annex.		
* Special categories of cited documents : *A* document defining the general state of the art which is not considered to be of particular relevance *E* earlier document but published on or after the international filing date *L* document which may throw doubts on priority claim(s) or which is cited to establish the publication date of another citation or other special reason (as specified) *O* document referring to an oral disclosure, use, exhibition or other means *P* document published prior to the international filing date but later than the priority date claimed *T* later document published after the international filing date or priority date and not in conflict with the application but cited to understand the principle or theory underlying the invention *X* document of particular relevance; the claimed invention cannot be considered novel or cannot be considered to involve an inventive step when the document is taken alone *Y* document of particular relevance; the claimed invention cannot be considered to involve an inventive step when the document is combined with one or more other such documents, such combination being obvious to a person skilled in the art. *&* document member of the same patent family		
Date of the actual completion of the international search 6 November 2008		Date of mailing of the international search report 17/11/2008
Name and mailing address of the ISA/ European Patent Office, P.B. 5818 Patentlaan 2 NL - 2280 HV Rijswijk Tel. (+31-70) 340-2040, Fax: (+31-70) 340-3016		Authorized officer Van den Berg, G

INTERNATIONAL SEARCH REPORT

International application No
PCT/US2008/066305

C(Continuation). DOCUMENTS CONSIDERED TO BE RELEVANT		
Category*	Citation of document, with indication, where appropriate, of the relevant passages	Relevant to claim No.
A	EP 1 225 601 A (TOKIN CORP [JP] NEC TOKIN CORP [JP]) 24 July 2002 (2002-07-24) paragraphs [0008], [0014], [0028], [0029], [0031]; figure 4c -----	1-10, 19
A	JP 2002 222707 A (NEC TOKIN CORP) 9 August 2002 (2002-08-09) abstract -----	1-3, 5-8
A	US 2005/212643 A1 (KUROIWA KATSUTOSHI [JP] ET AL) 29 September 2005 (2005-09-29) paragraphs [0016], [0043], [0057], [0059]; figures 1, 2 -----	1, 2, 6-8
A	WO 97/05632 A (NORTHEAST VENTURES INC [US]) 13 February 1997 (1997-02-13) page 3, lines 1-10 -----	1, 11, 19

INTERNATIONAL SEARCH REPORT

Information on patent family members

international application No PCT/US2008/066305

Patent document cited in search report	Publication date	Patent family member(s)	Publication date
US 2004207500	A1	21-10-2004	NONE
JP 7283046	A	27-10-1995	NONE
US 6392525	B1	21-05-2002	NONE
EP 1286371	A	26-02-2003	CA 2390771 A1 22-02-2003 CN 1407598 A 02-04-2003 JP 2003141990 A 16-05-2003 KR 20030017373 A 03-03-2003 NO 20023939 A 24-02-2003 TW 569267 B 01-01-2004 US 2003062851 A1 03-04-2003
EP 1225601	A	24-07-2002	CN 1371106 A 25-09-2002 DE 60201193 D1 21-10-2004 DE 60201193 T2 08-09-2005 JP 2002217043 A 02-08-2002 KR 20020077795 A 14-10-2002 TW 578173 B 01-03-2004 US 2002097131 A1 25-07-2002
JP 2002222707	A	09-08-2002	NONE
US 2005212643	A1	29-09-2005	CN 1637964 A 13-07-2005 JP 2005210055 A 04-08-2005 KR 20050063682 A 28-06-2005 US 2007193022 A1 23-08-2007
WO 9705632	A	13-02-1997	AU 6686396 A 26-02-1997